

No. 700,224.

Patented May 20, 1902.

J. D. McRAE.
CENTRIFUGAL PUMP.

(Application filed Mar. 12, 1901.)

(No Model.)

5 Sheets—Sheet 1.

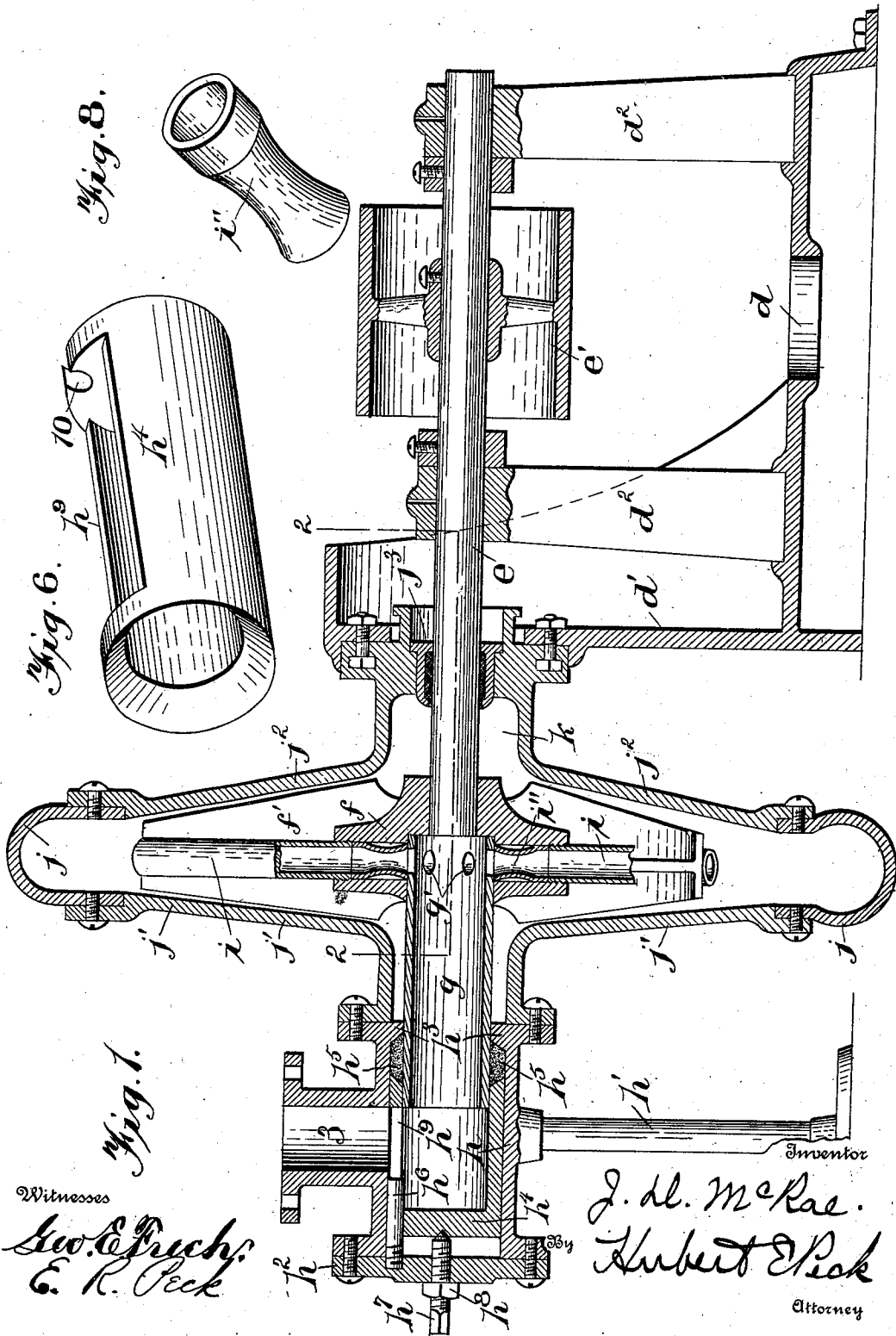

Fig. 8.

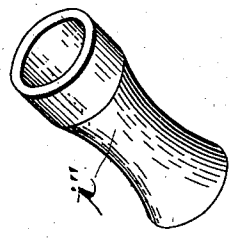
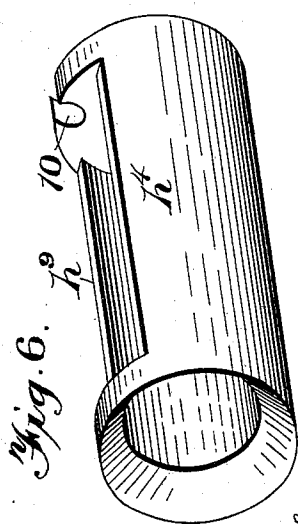

Fig. 1.

Witnesses
Geo. E. Peck
E. R. Peck

Inventor
J. D. McRae.
 Attorney
Hubert P. Peck

No. 700,224.

Patented May 20, 1902.

J. D. McRAE.
CENTRIFUGAL PUMP.

(Application filed Mar. 12, 1901.)

(No Model.)

5 Sheets—Sheet 2.

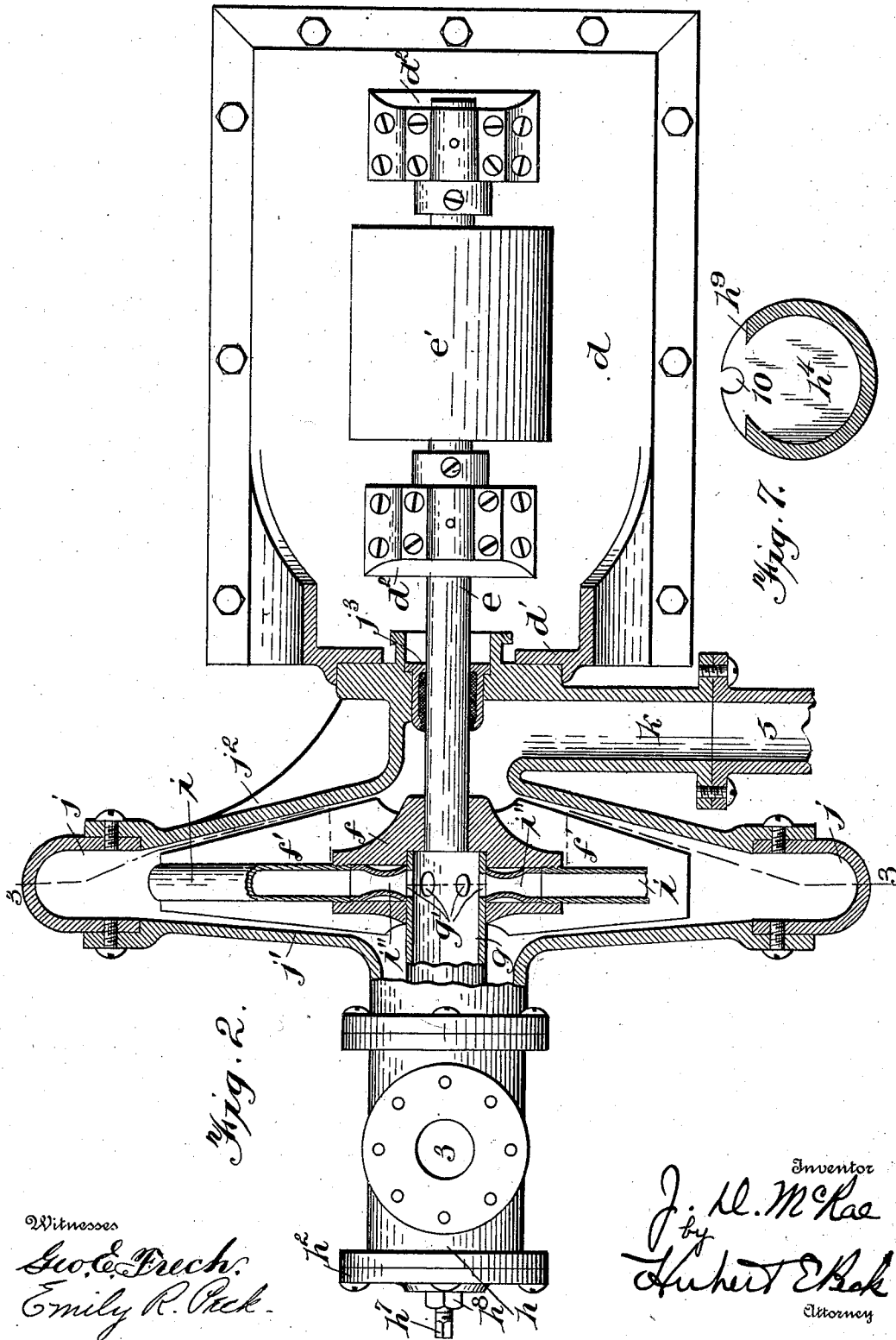

Witnesses

Geo. E. Precht.
Emily R. Peck.

Inventor

J. D. McRae
by
Hubert E. Peck
Attorney

J. D. McRAE.
CENTRIFUGAL PUMP.

(Application filed Mar. 12, 1901.)

(No Model.)

5 Sheets—Sheet 4.

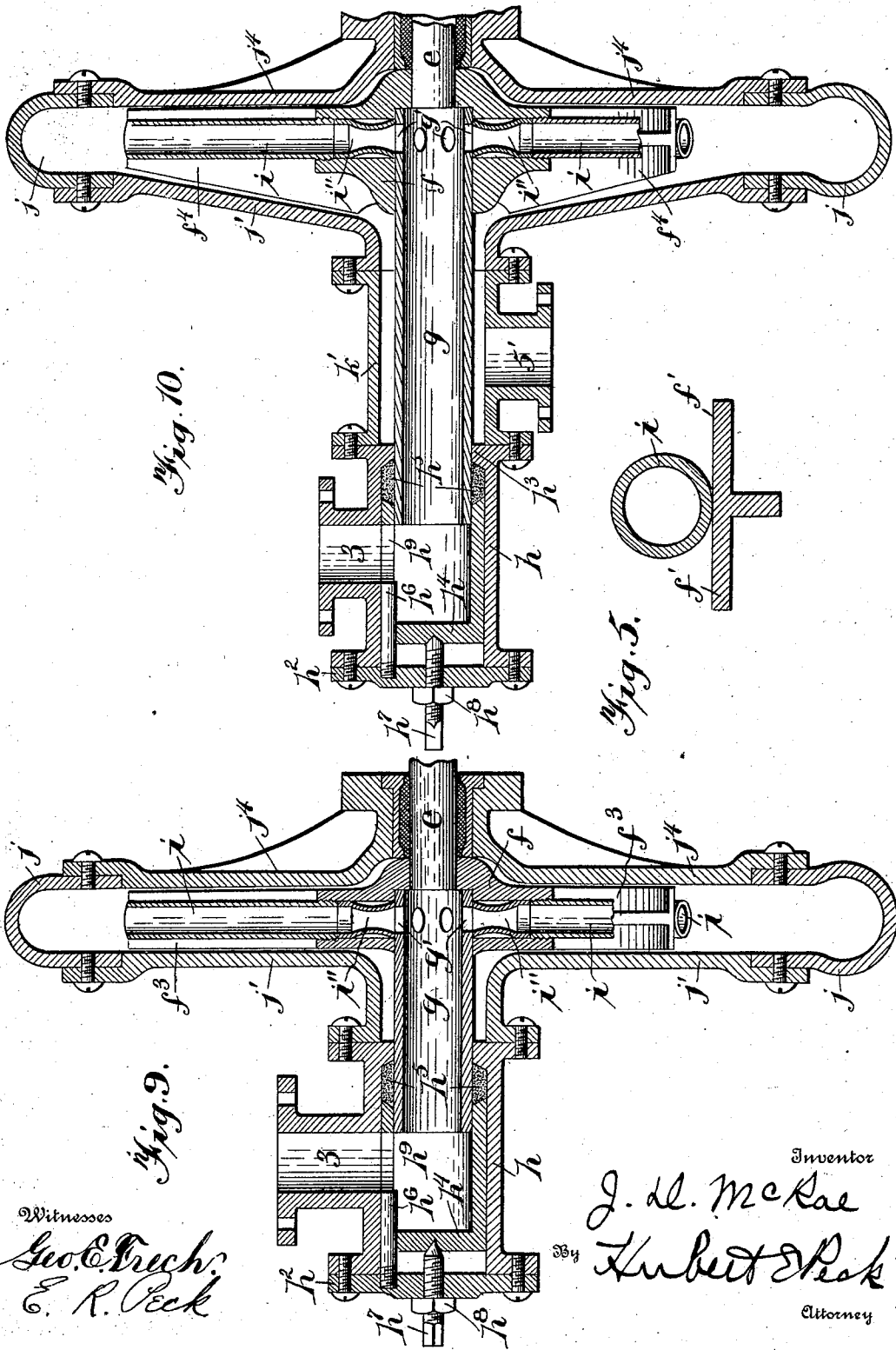

Fig. 10.

Fig. 5.

Fig. 9.

Witnesses
Geo. C. Truch.
E. R. Peck

Inventor
J. D. McRae
By Hubert Peck
Attorney

No. 700,224.

Patented May 20, 1902.

J. D. McRAE.
CENTRIFUGAL PUMP.

(Application filed Mar. 12, 1901.)

(No Model.)

5 Sheets—Sheet 5.

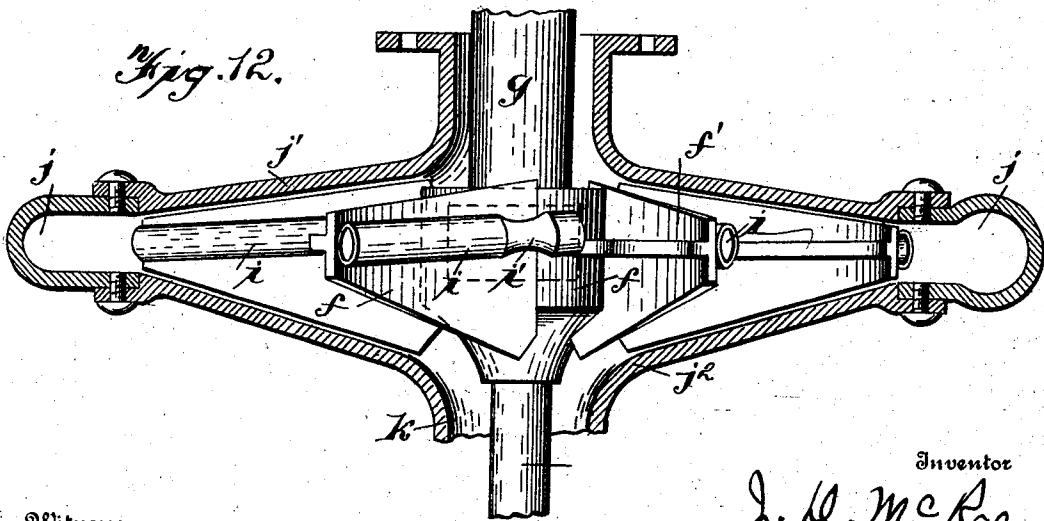
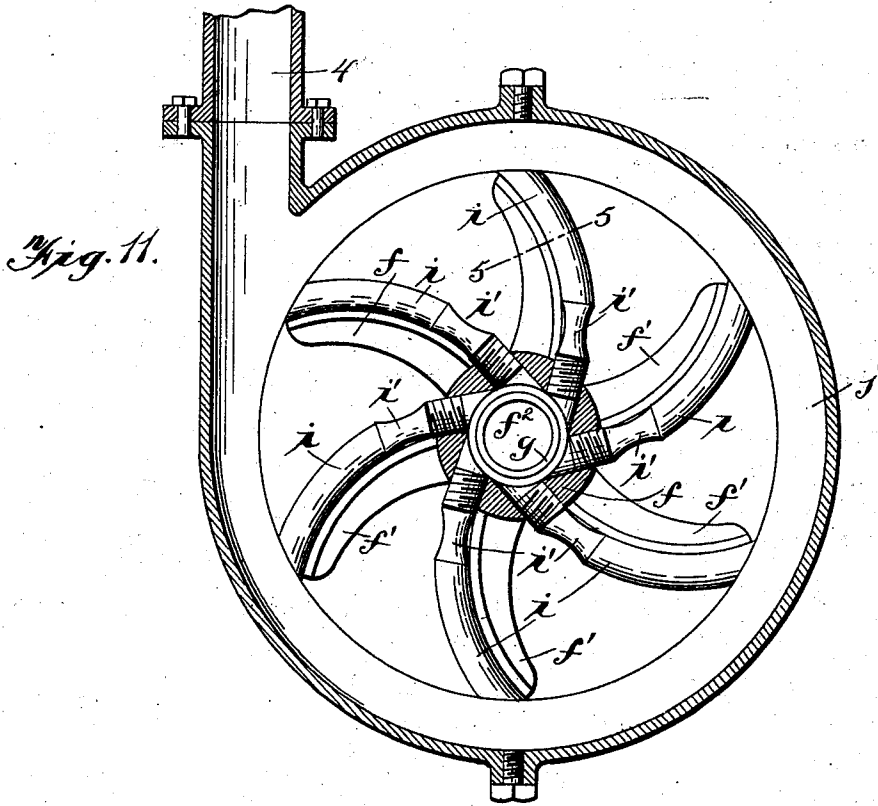

Witnesses
Geo. C. Frick
Emily R. Beck

Inventor
J. D. McRae
Hubert Peak
Attorney

384

UNITED STATES PATENT OFFICE.

JOHN D. MCRAE, OF OSWEGO, NEW YORK.

CENTRIFUGAL PUMP.

SPECIFICATION forming part of Letters Patent No. 700,224, dated May 20, 1902.

Application filed March 12, 1901. Serial No. 50,864. (No model.)

To all whom it may concern:

Be it known that I, JOHN D. MCRAE, a citizen of the United States, residing at Oswego, Oswego county, New York State, have invented certain new and useful Improvements in Centrifugal Pumps; and I do hereby declare the following to be a full, clear, and exact description of the invention, such as will enable others skilled in the art to which it appertains to make and use the same.

This invention relates to certain improvements in centrifugal pumps; and the objects and nature of my invention will be readily understood by those skilled in the art from the following explanations of the constructions shown in the accompanying drawings as examples, from among others, of devices within the spirit and scope of my invention.

My invention consists in certain novel features in construction, in combinations of parts, and in arrangements of details, as more fully and particularly pointed out and described hereinafter.

Referring to the accompanying drawings, Figure 1 is a vertical central section of a form of centrifugal pump constructed in accordance with my invention. Fig. 2 is a sectional plan, the section being taken in the plane of the line 2 2, Fig. 1. Fig. 3 is a cross-section taken in the plane of the line 3 3, Fig. 2. Fig. 4 is a detail sectional plan view enlarged, the pump-casing being broken away and the pump-runner shown in sectional broken-away top plan. Fig. 5 is a detail cross-section, enlarged, taken in the plane of the line 5 5, Fig. 3. Fig. 6 is a detail perspective view, enlarged, of the adjusting gland or bushing, in which the hollow runner-journal rotates. Fig. 7 is a detail cross-section of the gland or bushing of Fig. 6. Fig. 8 is a detail perspective of one of the removable suction-tube contracted sections or suction-nozzles. Fig. 9 is a vertical central section illustrating a modified form of pump casing and runner. Fig. 10 is a vertical central section illustrating another modified form and arrangement of pump casing and runner. Fig. 11 is a sectional elevation of a modified form of pump casing and runner. Fig. 12 is a sectional top plan view of the construction shown in Fig. 11.

In the drawings, *d* is a bed-plate, base, or frame, which can be of any suitable or de-

sirable construction and in the present instance is arranged horizontally with a suitably-braced upwardly-extending end web or wall *d'*, to which a pump-casing head is bolted or otherwise secured, as hereinafter set forth.

d² d³ are pillow-blocks or supports rigid with and extending up from the base and at their upper ends provided with suitable aligned journal-boxes. *e* is the horizontal rotary pump-runner shaft, mounted in said journal-boxes.

e' is the driving-pulley, secured to the shaft between the journal-boxes and adapted to be coupled with any suitable source of power for rotating the shaft at the rate of speed desired. The shaft and pump-runner carried thereby can be driven by belt or otherwise from a steam-engine, electric motor, or any other suitable power. The shaft extends through and outwardly beyond an opening in the vertical end wall *d'* of the frame and at its outer end is rigidly secured in the hub of the rotary pump-runner.

The pump-runner or rotary head comprises the central hub *f*, rigid with the radiating arms of blades *f'*, equally spaced and all of the same length. If desired, the hub and its arms can be formed of one casting. In the example shown the arms longitudinally curve outwardly and rearwardly from the hub and each arm has a broad flat front face and is braced or strengthened along its rear face by a central longitudinal rib or flange. Also in the forms shown in several figures each arm tapers or decreases in width from the hub to its outer end. The hub is formed hollow or with an interior concentric water-chamber having a concentric opening through the end of the hub opposite the inner end of the shaft *e*. A hollow journal *g* is rigidly secured in said end opening of the hub and extends outwardly therefrom concentrically with the axis on which the runner rotates. This hollow journal is formed of a hollow cylinder or straight cylindrical section of pipe with open ends, the inner open end opening into or forming the water-chamber of said hub. Suitable mechanism is provided to form a water-tight joint around said pipe or hollow runner-journal and yet permit open liquid communication between said journal-pipe and a duct or passage thereto. As an example of what might be employed for this pur-

pose I provide a T or other form of pipe-section, coupling, casing, or casting h , arranged at the outer side of and secured to the pump-casing or a head thereof, as hereinafter described, with the horizontal portion of said T-casing in continuation of and concentric with the axis of said tubular journal or pipe g , which extends thereinto and turns therein. The outer end of the casing h is tightly closed in any suitable manner, as by a plate or head h^2 , bolted or otherwise secured thereto. The casing h has the intermediate upwardly-extending flanged branch or passage 3, to which any suitable duct or chamber can be coupled or joined. h' is a strong or rigid leg or support extending from the ground or floor up to said casing to aid in supporting the same and the parts carried thereby or mounted thereon.

The journal-pipe g , rigid with the pump-runner, has an exterior diameter less than the internal diameter of the horizontal portion of the tubular casing h , into which it concentrically projects the necessary distance. The said journal-pipe is surrounded within said tubular casing by any suitable packing in which the pipe turns and which is designed to form a tight joint around the same to prevent leakage between the casing and said journal-pipe. As an example of what may be employed for this purpose, I show the inner end of the casing formed with an internal annular flange or shoulder h^3 , surrounding the pipe-journal. h^4 is a cylinder, sleeve, bushing, or gland arranged longitudinally within the casing concentric with said journal-pipe and of such internal diameter that the end of the journal-pipe projects a short distance thereinto and turns therein. The inner end of said cylinder around the journal-pipe opposes and is arranged opposite the flange or shoulder h^3 , before described, and suitable packing material h^5 surrounds an intermediate portion of the journal-pipe and is interposed and compressed between said shoulder h^3 and said end of said cylinder h^4 . Said end of the cylinder and inner edge or face of the shoulder h^3 can be beveled, as usual, to force the packing to the journal-pipe and maintain the tight joint. It will be observed that the inner end of said cylinder h^4 is open to receive the end of the pipe-journal, while the outer end thereof is closed and arranged opposite or adjacent to the end head h^2 of the casing h . The said cylinder is held against rotation, but is longitudinally adjustable, so that the packing or joint can be adjusted to take up wear. Various devices can be employed to thus hold the cylinder against rotation and yet permit longitudinal adjustment of the same. As an example of convenient means for this purpose I show a notch or recess 10 cut or otherwise formed in the end portion of the cylinder to receive the pin h^6 , arranged longitudinally of the cylinder and secured in the end head h^2 of the casing. This rigid pin fitting in the recess or notch in the cylinder holds the same against rota-

tion and yet permits the cylinder to slide in the casing longitudinally of the pin.

The device shown for adjusting the gland consists of the screw-bolt h^7 , screwing in a hole tapped through the head h^2 and having a conical end fitting and turning in a conical socket in the closed end of the cylinder h^4 , so that the cylinder can be forced inwardly by screwing in the bolt. The bolt is shown provided with a jam-nut h^8 at the outer face of the end head h^2 for locking the bolt. The cylinder is formed with the longitudinal slot or opening h^9 , registering with the suction or induction passage 3, to permit free passage of the liquid, vapors, or gases through the passage 3, cylinder 4, and journal-pipe g into the central water-space or hollow hub of the pump.

Suitable mechanism is provided to maintain and create a comparatively high degree of suction through the hollow journal of the runner, and hence create a partial vacuum in the duct communicating therewith, and thereby draw the water and vapors therefrom and discharge the same centrifugally or otherwise from the interior of the runner-hub into and from the pump-casing under the necessary pressure. As an example of means which might be employed for this purpose I show a series of water ducts or passages radiating from and opening into the internal water space or chamber of the runner, having open outer ends discharging into the shell of the pump-casing. I have devised a peculiarly advantageous construction and arrangement of radiating liquid-passages in connection with the centrifugal-pump runner. For instance, the radiating liquid-passages might be formed by tubes, although the broad features of my invention are not so limited. In this connection i denotes suction-tubes approximately radiating from the runner-hub. The hub is formed with openings into its central water-space, and the inner ends of said tubes are rigidly secured in any suitable manner in said openings of the hub, so that their inner ends open into said water-space. If desired, the ends of said suction-tubes can open into water-chamber f^2 and extend into the hub tangentially of the axis of the hub and runner, approximately as shown in Figs. 11 and 12 of the drawings, and the tubes from thence curve longitudinally rearwardly and outwardly, approximately as shown. I prefer that the tubes opening into the one central water-chamber be all of equal capacity and length and that they be equally spaced around the runner. As I am at present advised, it is preferable to have the suction-tubes equal in number with the runner arms or blades and to arrange each suction-pipe longitudinally along the front face of a runner and conforming generally to the rearward and outward longitudinal curve of the runner-arm, with the open outer ends of the tubes slightly projecting beyond the ends of the runner-arms and cut off at an angle or on a curve or arc about con-

centric with the axis of the runner. However, I do not desire to limit myself to these specific constructions and arrangements, although, as at present advised, specific advantages are attained thereby. If the tubes are made of sufficiently strong and heavy material, it will not be necessary to secure or fasten them to the runner-arms, as the tubes will be rigidly held in place by their inner ends screwed or otherwise fastened into the runner-hub:

In the specific examples shown in the drawings a pump-runner is shown which would be complete and operative so far as its exterior action on the liquid within the casing is concerned without the suction-passages, which in the example shown are formed by separately made and secured tubes. I have provided such a pump-runner with peculiar internal arrangements and passages, which, as I am at present advised by experience, do not modify the exterior action of the runner on the liquid within the casing; but the suction or pull created within said internal passages is enhanced and increased by the exterior action of the said runner on the liquid within the casing. I find that the efficiency of the runner through said suction-passages is increased by projecting the outer discharge ends of said passages beyond the circle in which the body of the runner revolves in order to attain the desired peripheral speed at the outer ends of said passages to create the necessary suction in the said passages for drawing therethrough the mixture of water and vapor. It is desirable to project the outer discharge ends of the suction-passages beyond the exterior surface of the runner itself and into the annular water space or shell surrounding the runner, so that the exterior action of the runner on the water within the casing will aid or increase the suction or pull through said passages and so that air or vapor discharged from said passages will be deposited on the inner surface of the annular shell or trough of the pump-casing and form a film thereon, and thereby reduce "skin friction." Advantages are also attained by having the discharge ends of the suction-passages open outwardly directly into the water-space around the runner—that is, so that the planes of the openings of the passages will be all approximately included in the circle in which said ends move in contradistinction to arrangements wherein the planes of said openings might be at decided angles to said circle as opening forwardly or rearwardly with respect to the direction of rotation of the runner. In the specific example shown I prefer, as at present advised, to cut off the ends of the tubes at an angle in the direction about as shown, other than at a right angle to the axis of the tube. Where the suction-passages are formed by separate tubes, as in the example illustrated, it is desirable to conform the tubes longitudinally to the runner-arms and on the front sides thereof, whereby

the tubes are braced and strengthened under centrifugal action during the rapid rotation of the runner, and the outward rush of water along the runner-arms tends to increase the "pull" or suction through said tubes.

To increase the suction and efficiency of the tubes during the rotation of the runner, I can form the liquid passage or duct of each tube length with an intermediate contracted portion *z'* (see Figs. 11 and 12) in the form of a double cone or taper, preferably on gradual curved lines. As at present advised, I deem it preferable that this contracted portion be located as near the inner ends of the radiating suction-passages as possible. The tubes are internally open and unobstructed throughout their lengths, except for said contracted portion of each tube, which, however, I may not use in all instances. Although I now consider it an important improvement and valuable adjunct for certain conditions, yet I do not desire to limit the broad features of my invention thereto.

Figs. 11 and 12 show each suction-tube composed of a single tube length annularly compressed between its ends to form the contracted portion or suction-nozzle *z*. Hence certain practical disadvantages or inconveniences might arise where such a construction is employed or is to be installed in instances where it is desired to change the capacity or the efficiency of the suction-tubes by not employing said contracted suction-nozzles or by employing nozzles of a different internal area. I have hence shown in other views of the drawings a simple construction and arrangement whereby the radial suction-passages can be relieved of the contracted suction-nozzles should conditions arise or be encountered where such removal would seem desirable and also whereby the suction-nozzle can be easily removed and replaced by different nozzles. For instance, I show a simple and convenient means for carrying these objects into effect in Figs. 1, 2, 3, 4, 8, 9, and 10, in which the runner-hub is formed with the series of radial passages at their inner ends opening into the central or concentric chamber of the hub. The journal-pipe *g* is shown extending throughout the length of this central chamber of the hollow hub and intersecting the inner ends of said radial passages. The journal-pipe is formed with radial openings or outlet passages *g'*, coinciding with the inner ends of said radial passages, respectively, but preferably having slightly shorter diameters than said radial passages or otherwise so formed as to provide abutments or shoulders at the inner ends of said radial passages. The radial passages are internally screw-threaded at their outer portions to receive the inner screw-threaded ends of the suction-tubes *z*, which extend into said passages for comparatively short distances or only such distances as may be necessary to properly secure the tubes. Each tube *z* is open and of approximately the same diameter throughout its

length. Separate contracted tube-sections or suction-nozzles i'' are employed, each having the double-cone contracted interior. These nozzles are usually without exterior screw-threads, and each is of such a length and external size as to drop into a radial passage of the runner-hub and at its inner end abut against the shoulder formed by the journal-pipe g (or any other suitably-formed shoulder) and extend from thence outwardly in the passage about to the screw-threaded portion thereof, so that when a tube i is screwed into said passage the inner end of the tube will abut against the outer end of the nozzle or section and lock the same between the tube and shoulder. It will thus be noted that if for any reason it should be desired to use the pump without the contracted nozzles or tube-sections the various tubes i can be unscrewed from the runner-hub and the said nozzles be removed and the tubes i be then again placed in their proper positions. When this has been done, the tubes will be in outward continuation of the passages in the hub. In the same way the nozzles can be easily replaced by nozzles of different capacity as conditions vary. Contracted nozzles i'' of various internal capacities can be easily made and kept in stock, so that whenever a pump is installed it will be a simple and easy matter to insert, possibly after several tests, the exact nozzles necessary to meet the peculiar conditions of the particular plant, which possibly cannot always be determined until the pump has been set up and tested a number of times. According to the state of the art prior to my invention, as I am at present advised, my invention in this particular comprehends various other constructions and arrangements, whereby interchangeable suction-nozzles can be employed in the same runner and with the same radial suction-passages, whether or not said radial passages be formed by separate tubes or otherwise.

The pump-casing can be of any suitable and desirable construction. The closed casing shown in the drawings merely as an example consists of two end heads and the annular trough-like shell j , forming a water space and passage around the runner and from which the tangential discharge 4 opens, as shown in Fig. 3, to which any suitable discharge or lift pipe can be bolted or otherwise secured. This shell j is secured to and between the outer surrounding edges of the two heads j' and j'' . The head j' has the central opening through which the hollow journal g of the runner centrally passes, which opening is surrounded by the flanged neck of said head, bolted or otherwise rigidly secured to the inner end of the casing h , as clearly shown in Figs. 1 and 2. The opposite head j'' is bolted or otherwise rigidly secured to the vertical web or wall d' of the bed-plate or frame and has an opening for the passage of the runner-shaft and a water-tight joint or bearing j^3 for said shaft. In the specific ex-

ample illustrated in Figs. 1, 2, 4, and 12 the end head j'' is formed with a suction or inlet duct k , extending laterally thereinto and then turning inwardly and opening into the central portion of the casing and around and concentric with the inner portion of the runner-shaft. As shown in Fig. 2, said head j'' is provided with an annular flange around the outer end of said suction-duct k , to which the suction-pipe 5 from any desirable source is bolted or otherwise secured. It will thus be observed that the suction created by the rotation of the runner head or arms acts through the duct k and pipe 5 on the source connected therewith, and the water therefrom is drawn directly into the casing at the central portion of the runner and around the hub thereof and is directly acted on by the runner-arms to cause the discharge of the water under sufficient head or pressure through the discharge-pipe or uptake 4, together with the liquid drawn in by the radiating suction-passages of the runner.

From the foregoing description it will be observed that the rotation of the runner at the necessary rate of speed will through the medium of the radiating suction-tubes create suction through the hollow journal and intermediate duct and in the source or device connected therewith, which will not only rapidly draw the water therefrom, but will also create a partial vacuum therein. The water will be discharged from the tube ends into the shell of the casing. From experience I am of the opinion that the revolving radiating tubes will create an exceedingly strong suction through the hollow journal and enable the water and air, vapor, or gases to be withdrawn very rapidly and under considerable head or pressure from the source and that the suction will be most materially enhanced or increased by the double-cone contractions included in the radiating passages. The rotation of the same runner not only creates suction through the medium of the tubes, but through the medium of the runner-arms acting centrifugally on the fluid in the casing suction or partial vacuum is maintained through the end duct k , and hence water is drawn from another source and through said end duct directly into the interior of the casing. The centrifugal action on all this water in the casing caused by the rapid rotation of the runner-head forces the water out through the discharge or uptake under a head or pressure which depends on the capacity and efficiency of the pump, which efficiency to a certain degree depends on the closeness of the fit of the runner-arms within the casing-heads, other conditions being equal. In several of the examples shown in the drawings the water drawn into the casing-shell through and by the action of the radial suction-passages (however formed, whether by tubes or otherwise) is combined in the casing-shell with the water drawn in by the action of the runner-head, and all of the water in the shell is acted

on by the centrifugal action of the rotating runner whatever its exterior form and forced through the single or common pump discharge under pressure. From experience I am at present of the opinion that the runner-arms cooperate with the suction-tubes in creating or maintaining a comparatively high degree of suction through said tubes, so that such a pump as I have described herein is of high efficiency and value for employment in many connections and under various conditions whether or not the end suction-duct or its equivalent opening directly into the casing be employed.

In the construction shown in Fig. 9 the pump is formed to draw from only one source and has only one suction inlet or duct, the suction being maintained through the medium of the radiating tubes. Hence the runner-head only cooperates with the tubes and forces the water drawn through the tubes centrifugally under the necessary pressure from the pump-casing through the tangential discharge. (Shown in other views of the drawings.) I hence show in said Fig. 9 a narrow runner-head having comparatively narrow runner-arms f^3 . The casing is correspondingly modified to receive the narrow runner, and the end head j^4 has no suction-duct there-through and is secured direct to the frame or base-plate.

In Fig. 10 I show a modified arrangement of pump having the casing-head j^4 secured to the bed-plate and through which the runner-shaft passes without the suction-duct opening therethrough. The opposite end head j^5 of the casing is shown with the central opening through which the hollow journal passes, but said opening is considerably larger in internal diameter than the external diameter of said journal, forming a suction-duct around the same and opening into the pump-casing. A pipe connection k' is interposed between and secured to the said casing-head j^5 around said opening and the casing h . The hollow journal passes through this pipe k' and is packed in the casing h , as before described, although said journal is shown in this view somewhat exaggerated in length for purposes of illustration. A suction-duct is thus formed around, yet having no liquid communication with, said hollow journal. The said pipe k' is formed as a T or with a lateral flanged branch $5'$ to receive the duct 5. (Shown in other views.) Both suction-ducts of the pump are shown concentrically arranged and both open through one head of the casing, and consequently it is usually desirable in this connection to form the runner-arms f^4 about as shown in said Fig. 10, although the invention is not so limited.

I do not in all instances, as at present advised, desire to limit the broad features of my invention to the specific means shown for establishing suction communication between the rotating hollow journal and a duct or chamber, although the arrangement shown

for establishing suction communication and providing a packed joint is exceedingly simple and effective and is one among other valuable features of the invention.

It is evident that various changes might be made and modifications resorted to in the forms, constructions, and arrangements of the parts described without departing from the spirit and scope of my invention. Hence I do not wish to limit myself to the exact constructions shown.

Having thus fully described my invention, what I claim as new, and desire to secure by Letters Patent of the United States, is—

1. In combination, in a centrifugal pump, a pump-casing having a discharge, a rotary pump-runner exteriorly formed with runner-arms to act centrifugally on the liquid in the casing and force the same through said discharge, said casing forming an annular water-space circumferentially around said runner, said runner provided with a series of suction-tubes of substantially uniform area and form in cross-section throughout and at their outer ends discharging into said annular water-space, and an axial suction-duct in direct suction communication with the inner ends of said tubes, substantially as described.

2. In a centrifugal pump, in combination, a casing having a suction-opening and a discharge, and a rotary runner therein comprising a hollow hub, radiating arms or blades rigid with the hub, and suction-tubes arranged along said arms and at their inner ends opening into said hub, and an axial suction-pipe opening into and rigid with said hub, substantially as described.

3. A centrifugal pump comprising a casing and a rotary runner acting on the liquid in the casing, to force the same therefrom under centrifugal pressure, said runner provided with radiating suction-passages at their outer ends discharging into the casing, an axial suction pipe or duct in liquid and suction communication with the inner ends of all said passages, said passages formed at their inner ends with curved contracted portions, substantially as described.

4. In combination, in a centrifugal pump, a casing having a discharge, a rotary pump-runner exteriorly formed to drive the water centrifugally and circulate the same within said casing, and provided with outwardly-extending suction-passages consisting of suction-tubes of substantially uniform area and form in cross-section throughout and having exposed outer ends opening directly into the space around said runner, and an axial suction-duct to the inner portions of said passages, substantially as described.

5. A centrifugal pump comprising a casing having a discharge and a suction-duct opening directly into the interior thereof, a rotary pump-runner in the casing exteriorly formed to act centrifugally on the liquid within the casing and force the same through said discharge, said runner provided with outwardly-

extending suction-passages at their outer ends discharging directly into the casing, and a suction-duct in direct suction communication with the inner ends of said suction-passages, substantially as described.

6. In a centrifugal pump, the combination of a pump-casing having a circumferential discharge, a rotary runner in the casing comprising a hub and runner-arms formed to act centrifugally on the water in the casing in driving the same outwardly to and around the circumferential portion of the casing, suction-tubes secured in the hub between said arms and extending outwardly along said arms and at their outer ends discharging into the circumferential portion of the casing, a hollow suction-journal in direct suction communication with the inner ends of said tubes, a suction-duct in communication with said journal, and a tight joint for said journal, substantially as described.

7. In a centrifugal pump, the combination of a pump-casing having a discharge, and a suction-inlet opening directly into the interior of the casing, a rotary pump-runner exteriorly formed to act centrifugally on the water in the casing to create suction through said inlet and drive the water through said discharge, a suction-duct rigid with and extending from said casing, said runner provided with a hollow suction-journal extending into and rotating in said duct and with suction-passages at their outer ends discharging into the circumferential portion of the casing and at their inner ends in direct suction communication with said journal only, and a tight joint in said duct and around said journal, whereby water is drawn into the casing through said inlet and also through said journal and passages, substantially as described.

8. In combination, a supporting-frame, a centrifugal-pump casing having an end opening, an outwardly-extending coupling secured thereto having a closed outer end and an induction-opening, a rotary runner, a drive-shaft therefor, a hollow journal rigid with the runner and projecting into said coupling, said runner having radiating suction-passages communicating with said journal, a packed joint in said coupling around said journal, and adjusting means for said joint extending to the exterior of said coupling, substantially as described.

9. In a centrifugal pump, in combination, a casing having a discharge, a rotary runner therein comprising a hub having radiating arms and a shaft, a hollow journal rigid with said hub and provided with a packed joint, and radiating suction-tubes rigid with the hub and arranged between and extending longitudinally of said arms, the outer ends of the tubes discharging into the casing and the inner ends thereof opening into said journal.

10. In a centrifugal pump, the combination of a pump-casing having a discharge, a rotary pump-runner comprising a hub, an axial suction-duct, outwardly and rearwardly

extending runner-arms and a series of suction-tubes at their inner ends secured in the hub in suction communication with said duct and from thence extending outwardly along and conforming to the front faces of said arms, said casing forming a water-space circumferentially around said runner, the outer ends of said tubes opening directly into said space, substantially as described.

11. In a centrifugal pump, in combination, a rotary runner having a hollow journal and a series of suction-tubes at their inner ends in direct suction and liquid communication with said journal and having their open outer ends projecting beyond the outer circular path of the runner itself, substantially as described.

12. In a centrifugal pump, the combination of a runner comprising outwardly-projecting runner-arms and rigid suction-tubes at their inner ends in direct suction communication with a suction-duct, the outer open ends of the tubes projecting beyond the circle in which the outer ends of said arms move, and each cut off at an angle, substantially as described.

13. In combination, in a centrifugal pump, a pump-runner having an axial suction-duct and a series of outwardly-extending suction-passages opening into the pump-casing at their outer ends and at their inner ends opening into said suction-duct, each suction-passage having an internal oppositely tapered or curved contraction.

14. In combination, in a centrifugal pump, a rotary pump-runner having a hollow hub with a supply or suction duct thereto and outwardly-projecting suction-passages at their inner ends communicating with said duct and at their inner portions provided with oppositely-tapered or double-cone contracted suction nozzles or portions, substantially as described.

15. A centrifugal-pump runner comprising a hollow hub with radiating runner-arms and having a shaft and a hollow journal, a suction-duct receiving said journal, a packed joint in said duct for said journal, and a series of outwardly-projecting removable suction-tubes between said arms and at their inner ends secured in said hub, substantially as described.

16. In a centrifugal pump, in combination, a pump-casing having a circumferential water-space and a discharge, a rotary pump-runner exteriorly formed to act centrifugally on the liquid in the casing and drive the liquid to and circulate the same in said space, said runner provided with suction-passages of substantially uniform area and form in cross-section throughout having longitudinally-exposed tube-like outer ends discharging directly into said space, and a suction-duct in direct suction communication with the inner ends of said passages, substantially as described.

17. In combination, a centrifugal-pump

shell, a casing rigid with and extending laterally therefrom, a rotary pump-runner having a hollow journal in said casing, a packed joint in said casing for said journal, a gland in the casing for said joint, gland-adjusting means extending to the exterior of the casing, a suction-duct to the casing and said journal, said runner having radiating suction-passages communicating with said journal and discharging into the pump-shell, substantially as described.

18. In combination, a centrifugal-pump shell having a laterally-projecting casing, a rotary pump-runner having a hollow journal in said casing and suction discharge-passages from the journal opening into the shell, a packed joint within the casing around said journal, a gland on the journal, means holding the gland against rotation, a duct opening into said casing opposite said gland, said gland having an inlet-opening establishing liquid and suction communication from said duct through said journal, and an adjusting-bolt passing through the casing to longitudinally adjust the gland, substantially as described.

19. In a centrifugal pump, the combination of a pump-casing having a circumferential water space or shell with a discharge, a rotary pump-runner in said casing, surrounded by said water-space, and comprising a hub and outwardly-projecting runner-arms, said runner provided with a projecting hollow journal and a series of suction-passages at their inner ends opening into said journal and at their outer ends projected beyond said arms and discharging directly into said water-space within the casing, a suction-duct in direct suction communication with the outer end of the journal, and a joint around an intermediate portion of said journal and shutting off direct communication between said duct and the interior of the pump-casing, substantially as described.

20. In a centrifugal pump, the combination of a pump-casing having a discharge, a coupling extending axially from said casing and having a suction-opening, a pump-runner in said casing and formed exteriorly to act centrifugally on the liquid in the casing and force the same therefrom through said discharge, said casing having a suction-duct opening directly thereinto at the exterior of said runner, said runner formed with suction-passages at their outer ends discharging into the casing, a hollow journal in suction communication with the inner ends of said passages, said journal fitting snugly in said coupling and at its outer end in direct suction communication with said suction-opening of said coupling, and a packing in said coupling and around said journal, substantially as described.

21. In combination, a centrifugal-pump casing having a discharge, a rotary runner having suction-ducts discharging into the casing and a hollow journal discharging to the inner ends of said passages, an inlet-duct, a coupling

therefrom to said hollow journal placing the journal in direct suction communication with said duct and a packed joint between the journal and coupling and comprising an adjustable gland in the coupling and receiving said journal and held against axial movement, and having a side inlet-opening, substantially as described.

22. In a centrifugal pump, the combination of a pump-casing having a circumferential water-space with a discharge, a rotary pump-runner fitted in the casing and surrounded by said space and exteriorly formed to force the water in the casing centrifugally into said space and circulate the same therein, said runner provided with a hollow journal and with radiating suction-passages at their inner ends opening into said journal and having their outer ends projected beyond the outer circle of movement of said runner and discharging directly into said water-space, a supply or suction duct opening to said hollow journal, and a liquid-tight joint around said journal, substantially as described.

23. A centrifugal pump having its runner provided with a hollow suction-journal, a casing having an inlet-port, said journal projecting into said casing and having an inlet-opening therein, a packed joint in the casing for said journal comprising a gland in which the journal rotates, means for holding the gland against axial movement, and means accessible from the exterior of the pump for adjusting the gland longitudinally of the journal, substantially as described.

24. In combination, a casing, a rotary pump-runner therein having a projecting hollow suction-journal, a T-coupling secured to the casing and receiving the journal, packing in the coupling around the journal, a sleeve in the coupling embracing the journal for adjusting the packing, and a screw from the exterior of the coupling for adjusting said sleeve longitudinally, substantially as described.

25. In combination, a centrifugal-pump casing having a coupling secured to a head thereof with a closed outer end and an annular internal shoulder, a pump-runner having a hollow suction-journal projecting into said coupling, packing in the coupling around said journal and at said shoulder, a sleeve in the coupling around said journal and opposing said packing and having a side inlet-opening and a closed outer end, a pin passing through said end to the outer end of the coupling, and a screw adjustable through the outer end of the coupling and engaging said sleeve, substantially as described.

26. A centrifugal-pump runner having radiating suction-passages provided with contracted suction-nozzles at their inner inlet ends, and a suction-duct discharging to the inner ends of said passages, substantially as described.

27. A centrifugal-pump runner having radiating suction-passages and separate suction-nozzles or contracted sections included

therein, and an axial suction-duct discharging to said passages, substantially as described.

28. A centrifugal-pump runner comprising radiating suction-passages at their outer ends discharging centrifugally into the pump-casing and an axial supply-duct to their inner ends, separate contracted suction sections or nozzles included in said passages and means for securing the same, whereby various nozzles can be used interchangeably with the same passages, substantially as described.

29. A centrifugal-pump runner having an axial supply-duct, and radiating suction-passages opening into said duct, separate contracted pipe sections or nozzles in said passages, and outwardly-projecting suction-tubes at their inner ends secured in said passages in outward continuation of said nozzles, substantially as described.

30. A centrifugal-pump runner having a hollow hub formed with radial passages, shoulders at the inner ends thereof, tube-sections in said passages at their inner ends abutting against said shoulders, and outwardly-projecting suction-tubes at their inner ends removably secured in said passages and abutting against said sections, substantially as described.

31. A centrifugal-pump runner having a hollow hub with an axial suction-duct, rigid radiating runner-arms and outwardly-extending suction-tubes arranged between said arms and creating suction in and drawing the liquid from said duct through the centrifugal action caused by the rapid rotation of the runner, said tubes at their inner ends independently and removably secured in said hub, substantially as described.

32. A centrifugal-pump runner, having a hollow hub and an axial supply-duct thereto, and outwardly-projecting suction-tubes therefrom having removable contracted suction-sections located in said hub, whereby the tubes can be employed with or without said sections.

33. In a centrifugal pump the combination of a pump-casing having a circumferential discharge and a suction-duct opening directly into said casing, a rotary pump-runner rotating close to the walls of the casing and creating suction through said duct by centrifugal action on the liquid in the casing at the exterior of the runner, a hollow journal for said runner, a suction-duct in direct communication therewith, a packed joint around said journal, said runner having radiating suction-passages at their outer ends discharging into the circumferential portion of the pump-casing and at their inner ends all in communication with said hollow journal, said radiating suction-passages shut off from suction communication except through said hollow journal.

34. A centrifugal pump comprising a casing having a discharge and an axial suction-duct opening into the interior of the casing at the

exterior of the runner, and a rotary runner in the casing, exteriorly formed to centrifugally drive the water in said casing to create suction through said axial duct, and having suction-passages therethrough discharging centrifugally into the casing, and a suction-duct discharging into and supplying said passages, the capacity of said passages being different from that of said casing suction-duct, substantially as described.

35. In a centrifugal pump, the combination of a pump-casing having a discharge, a rotary pump-runner therein and comprising radiating runner-arms acting centrifugally on the water in the casing to force the same therefrom under pressure and create suction therein, said runner provided with a hollow journal, a suction-duct in which said journal rotates, said runner formed with radiating suction-passages arranged longitudinally of said arms with their outer end portions exposed at the front faces of said arms and discharging directly outwardly about at the ends of the arms and with their inner ends in direct suction communication with said hollow journal, substantially as described.

36. In a centrifugal pump, the combination of a pump-casing, a pump-runner in the casing having radial suction-passages at their outer ends discharging into the casing, a hollow journal rigid with the runner and in communication with the inner ends of said passages, a T-coupling secured to the casing, said journal extending longitudinally into one branch of the T, another branch of the T forming a suction-opening, a packed joint in said first-named branch of the T and around said journal, a bushing arranged longitudinally in said coupling and around and projecting beyond the journal end and having an opening establishing suction communication between said journal and said suction-opening of the T, and means for adjusting said bushing longitudinally of said journal, substantially as described.

37. In a centrifugal pump, the combination of a pump-casing, a T-coupling secured thereto, a pump-runner in the casing having a hollow journal projecting into and provided with a tight joint in one of the branches of said T, a bushing arranged longitudinally in said coupling around said journal and maintaining said joint, said bushing having a side opening opposite the intermediate branch of said T, a duct secured on said side branch of the T, the remaining branch of the T being closed and provided with means for adjusting said bushing, substantially as described.

38. In a centrifugal pump, the combination of a pump-casing having a discharge and a lateral extension with a supply-opening, a rotary pump-runner in the casing exteriorly formed to centrifugally drive the water in the casing and force the same through said discharge, said runner having outwardly-extending suction-passages discharging into the casing and a hollow suction-journal discharging

into said passages and extending longitudinally into said extension, a packed joint for said journal, a longitudinally-slidable bushing fitted on and projecting beyond said journal and through which suction communication is maintained between said journal and said opening said bushing fitted snugly within and approximately throughout the length of said extension, and means for adjusting said bushing, substantially as described.

39. In a centrifugal pump, the combination of a pump-casing, a rotary pump-runner therein having a hollow suction-journal and provided with suction-passages at their inner ends in direct suction communication with said journal and at their outer ends opening outwardly directly into the interior of said casing beyond the outer circle of movement of the runner itself, the planes of said discharge-openings of said passages being included in the circle in which said discharge ends of the passages move, substantially as described.

40. In a centrifugal pump, the combination

of a pump-casing having a discharge, a rotary pump-runner therein, said casing forming a water-space circumferentially around said runner, said runner exteriorly formed to act centrifugally on the water in the casing in driving the same therefrom through said discharge, and provided with outwardly and rearwardly curved exposed tubular suction-passages at their outer ends opening outwardly directly into said water-space so that the water therein sweeps transversely across said open ends as the runner rotates, an axial suction-duct in suction communication with the inner ends of said suction-passages and means shutting off said suction-duct from communication with the casing interior except through said passages, substantially as described.

In testimony whereof I affix my signature in presence of two witnesses.

JOHN D. McRAE.

Witnesses:

W. V. BURR,
F. J. CURRIE.