

(12) PATENT
(19) AUSTRALIAN PATENT OFFICE

(11) Application No. AU 199645111 B2
(10) Patent No. 709498

(54) Title
Improved adenoviral vectors and producer cells

(51)⁶ International Patent Classification(s)
A61K 048/00 C12N 015/00

(21) Application No: 199645111 (22) Application Date: 1995 .12 .07

(87) WIPO No: W096/18418

(30) Priority Data

(31) Number	(32) Date	(33) Country
08/355087	1994 .12 .12	US
08/458403	1995 .06 .02	US

(43) Publication Date : 1996 .07 .03
(43) Publication Journal Date : 1996 .08 .22
(44) Accepted Journal Date : 1999 .09 .02

(71) Applicant(s)
Genetic Therapy, Inc.

(72) Inventor(s)
Michael Kadan; Mario Goziglia; Bruce Trapnell

(74) Agent/Attorney
SPRUSON and FERGUSON,GPO Box 3898,SYDNEY NSW 2001

(56) Related Art
WO 94/28152
WO 94/12649

OPI DATE 03/07/96 APPLN. ID 45111/96
AOJP DATE 22/08/96 PCT NUMBER PCT/US95/15947



AU9645111

CT)

(51) International Patent Classification⁶ : A61K 48/00, C12N 15/00	A1	(11) International Publication Number: WO 96/18418 (43) International Publication Date: 20 June 1996 (20.06.96)
(21) International Application Number: PCT/US95/15947 (22) International Filing Date: 7 December 1995 (07.12.95) (30) Priority Data: 08/355,087 12 December 1994 (12.12.94) US 08/458,403 2 June 1995 (02.06.95) US (71) Applicant: GENETIC THERAPY, INC. [US/US]; 938 Clopper Road, Gaithersburg, MD 20878 (US). (72) Inventors: KADAN, Michael; 1743 Greenfield Road, Adamstown, MD 21710 (US). GOZIGLIA, Mario; 8027 Lions Crest Way, Gaithersburg, MD 20879 (US). TRAPNELL, Bruce; 4023 Byrd Road, Kensington, MD 20895 (US). (74) Agents: LILLIE, Raymond, J. et al.; Carella, Byrne, Bain, Gilfillan, Cecchi, Stewart & Olstein, 6 Becker Farm Road, Roseland, NJ 07068 (US).	(81) Designated States: AU, CA, JP, NZ, European patent (AT, BE, CH, DE, DK, ES, FR, GB, GR, IE, IT, LU, MC, NL, PT, SE). Published <i>With international search report.</i>	
(54) Title: IMPROVED ADENOVIRAL VECTORS AND PRODUCER CELLS (57) Abstract <p>An adenoviral vector wherein the adenoviral genome has been modified to reduce the host immune and inflammatory responses to the vector. In one embodiment, the adenoviral vector including an adenoviral 5' ITR; an adenoviral 3' ITR; an adenoviral encapsidation signal; at least one DNA sequence encoding a protein or polypeptide of interest; and a promoter controlling the DNA sequence(s) encoding the protein(s) or polypeptide(s) of interest. The adenoviral vector is free of all or a portion of each of the adenoviral E1 and E4 DNA sequences, or is free of all or a portion of each of the adenoviral E1 and E2 DNA sequences, or is free of all or a portion of each of the E1, E2 and E4 DNA sequences. Also disclosed and claimed is a producer cell for generating adenoviral vector particles, wherein the producer cell includes an adenoviral E1 DNA sequence and an adenoviral E4 DNA sequence, or includes an adenoviral E1 DNA sequence and an adenoviral E2a DNA sequence, or includes the adenoviral E1, E2a and E4 DNA sequences.</p>		

Improved Adenoviral Vectors and Producer Cells

This invention relates to adenoviral vectors wherein the adenoviral genome has been modified to reduce the host immune and inflammatory responses to the vector. More particularly, this invention relates to adenoviral vectors which are free of all or a part of the adenoviral E1 and E4 DNA sequences, or are free of all or a part of the adenoviral E1 and E2 DNA sequences or are free of all or a portion of each of the E1, E2, and E4 regions and further may or may not contain some of the E3 region genes operationally linked to a functional promoter, and to producer cells for generating adenoviral particles from such vectors.

10

Background of the Invention

Adenovirus genomes are linear, double-stranded DNA molecules about 36 kilobase pairs long. Each extremity of the viral genome has a short sequence known as the inverted terminal repeat (or ITR), which is necessary for viral replication. The well-characterized molecular genetics of adenovirus render it an advantageous vector for gene transfer. The knowledge of the genetic organization of adenoviruses allows substitution of large fragments of viral DNA with foreign sequences. In addition, recombinant adenoviruses are structurally stable and no rearranged viruses are observed after extensive amplification.

15
 20
 25
 30
 35
 40
 45
 50
 55
 60
 65
 70
 75
 80
 85
 90
 95



Adenoviruses thus may be employed as delivery vehicles for introducing desired genes into eukaryotic cells, whereby the adenovirus delivers such genes to eukaryotic cells by binding cellular receptors, internalizing via coated pits, disrupting endosomes, and releasing particles to the cytoplasm followed by nuclear translocation and molecular expression of the adenovirus genetic program.

In general, an adenovirus genome includes the E1 region, the E2 region, the E3 region, the E4 region, and the major late region as well as several other minor regions. The E1 region provides functions associated with transformation, transcription upregulation, and control of replication. The E2 region is essential for DNA replication, and other viral functions including transcriptional regulation. The E3 region provides for the adenovirus' defense against the host's immune system. The E3 region encodes proteins which inhibit the host cell's ability to present viral proteins as foreign antigens. The E4 region is essential for several important viral functions, including control of late gene expression, shutting down host cell function by the virus, and virus replication. The major late region encodes the major adenoviral structural proteins.

Adenoviral vectors have been constructed in which at least a majority of the E1 and E3 sequences have been deleted. The E1 deletion renders the vector replication defective, the E3 region deletion provides space for insertion of the desired gene into the adenoviral vector without exceeding the maximum acceptable size for a packageable genome. Applicants have found that when such vectors have been placed into target cells or organs *in vivo*, however, a sharp decrease in expression of the desired gene results at about 1 to 3 weeks post-infection. In addition, it was found that an inflammatory response may develop in a target organ, and that the adenovirus vector may induce a cytotoxic T-lymphocyte (CTL) response directed against the

vector-transduced host cells. This CTL response has the effect of eliminating the host vector transduced cells from the host. Also, the host may develop a neutralizing antibody response to such adenoviral vectors.

It is therefore an object of the present invention to provide an adenoviral vector which minimizes host response to the vector and increases the duration of vector persistence and expression, and to provide producer cell lines which will generate adenoviral particles from such vectors.

BRIEF DESCRIPTION OF THE DRAWINGS

The invention now will be described with respect to the drawings, wherein:

Figure 1 is a schematic of the construction of plasmid pSE280-E1;

Figure 2 is a map of plasmid pMAMneo-Luc;

Figure 3 is a schematic of the construction of plasmid pMAMneo-E1;

Figure 4 is a schematic of the construction of plasmid pGRE5-E1 from pSE280-E1 and pGRE5-2/EBV;

Figure 5 is a map of plasmid pGRE5-E1;

Figure 6 a schematic of the construction of plasmid pMAMneo-E2A;

Figure 7 is a map of plasmid pSE380;

Figure 8 is a schematic of the construction of plasmids pSE380-E4 and pSE380-ITR/E4;

Figure 9 is a schematic of the construction of plasmid pSE380GRE5/E4;

Figure 10 is a map of plasmid pTZ18R;

Figure 11 is a schematic of the construction of plasmids pTZE2A and pTZdlE2A;

Figure 12 is a schematic of the construction of plasmid pSE380-E3⁺;

Figure 13 is a schematic of the construction of plasmids pSE380-E3⁺E4⁺ and pTZE3⁺E4⁺;

Figure 14 is a schematic of the construction of plasmids pTZE3E4⁺, pSE280E3E4⁺, and pSPORT-1 E3E4⁺;

Figure 15 is a map of plasmid pSPORT-1;

Figure 16 is a schematic of the construction of plasmid pSPORT-1E2AE3E4⁺;

Figure 17 is a map of plasmid pBR322;

Figure 18 is a schematic of the construction of plasmids pBR322-E2AE3E4⁺ and pBRAd5-E2AE3E4⁺;

Figure 19 is a schematic of the construction of plasmids pSE380-E4⁻ and pSE380E3⁺E4⁻;

Figure 20 is a schematic of the construction of plasmid pSE380E3⁺E4⁻(2);

Figure 21 is a schematic of the construction of plasmid pSE380E3E4⁻(2);

Figure 22 is a schematic of the construction of plasmid pSPORT1/E2AE3E4⁻(2);

Figure 23 is a schematic of the production of an adenoviral vector having the genotype E1⁺, E2A⁻, E3⁻, E4⁺;

Figure 24 is a map of pAvS6;

Figure 25 is a schematic of the construction of an adenoviral vector having the genotype E1⁻, E2A⁻, E3⁻, E4⁺ by homologous recombination;

Figure 26 is a schematic of the production of an adenoviral vector having the genotype E1⁻, E2A⁻, E3⁻, E4⁺ by in vitro ligation and transfection;

Figure 27 is a schematic of the production of an adenoviral vector having the genotype E1⁻, E2A⁻, E3⁻, E4⁺ by homologous recombination;

Figure 28 is a schematic of the vector Av3nLacZ;

Figure 29 is a schematic of the production of an adenoviral vector having the genotype E1⁺, E4⁻;

Figure 30 is a schematic of the production of an adenoviral vector having the genotype E1⁻, E2⁺, E3⁺, E4⁻ by homologous recombination;

Figure 31 is a schematic of the production of an adenoviral vector having the genotype E1⁻, E2⁺, E3⁺, E4⁺ by *in vitro* ligation and transfection;

Figure 32 is a schematic of the generation of Av4nLacZ by homologous recombination;

5 Figure 33 is a schematic of the generation of Av4nLacZ by *in vitro* ligation;

Figure 34 is a schematic of the generation of an Av4 (fourth generation adenovirus) type vector containing a transgene;

Figure 35 is a schematic of the construction of plasmid pAvS6-CFTR;

Figure 36 is an immunoprecipitation blot for adenoviral hexon expression in A549
10 cells infected with an Av1 type vector (having a deletion of all or part of the E1 region), an Av2 vector (having a deletion of all or part of the E1 region and a temperature-sensitive mutation in the E2a gene), or an Av3 vector of Ad dl327;

Figure 37 is an immunoprecipitation blot for adenoviral hexon expression in E1⁺E2⁺ cells or E1⁺ cells infected with an Av1 vector, an Av2 vector, or an Av3 vector; and

15 Figure 38 is a blot showing adenovirus vector DNA replication in E1⁺E2⁺ or E1⁺ cells infected with an Av1 vector, an Av2 vector, or an Av3 vector.

Summary of the Invention

The present invention provides for an improved adenoviral vector wherein the adenoviral genome has been modified to reduce the host immune and inflammatory
20 response to the vector. Such vector has a reduced viral DNA replication potential and reduced expression of adenoviral genes (e.g., hexon) in comparison to existing adenoviral vectors. Such modification(s) to the adenoviral genome may be effected through deletion(s) and/or mutation(s) of portion(s) of the adenoviral genome.

According to a first embodiment of the invention, there is provided an adenoviral
25 vector comprising a modified adenovirus genome including an adenoviral 5'ITR, an adenoviral 3'ITR, an adenoviral encapsidation signal, DNA encoding a heterologous protein or polypeptide, and a promoter controlling the expression of said DNA encoding a heterologous protein or polypeptide, wherein at least a portion of each of the E1 and E4 DNA sequence has been deleted to eliminate the function of each of the E1 and E4 early
30 proteins, at least a portion of at least one of the E2a and E2b DNA sequences has been deleted to eliminate the function of at least one of the E2a and E2b early proteins, and said vector retains at least a portion of the adenoviral protein function.



According to a second embodiment of the invention, there is provided a stable cell for complementing adenoviral early protein functions for use in the production of adenoviral vectors, comprising: a stable cell, including a first DNA sequence encoding the adenoviral E1 function, said first DNA sequence being under the control of a first inducible promoter; a second DNA sequence encoding the adenoviral E2 function, said second DNA sequence being under the control of a second inducible promoter; and a third DNA sequence encoding the adenoviral E4 function, said third DNA sequence being under the control of a third inducible promoter, said first, second, and third inducible promoters being the same or different.

According to a third embodiment of the invention, there is provided a method for the treatment of disease in a mammal, including a human, wherein said treatment comprises administering a therapeutically effective amount of the adenoviral vector in accordance with the first embodiment of the invention.

According to a fourth embodiment of the invention, there is provided the adenoviral vector in accordance with the first embodiment of the invention when used in the treatment of disease in a mammal, including a human.

According to a fifth embodiment of the invention, there is provided a method of effecting a gene therapy treatment, comprising: administering to a host the adenoviral vector in accordance with the first embodiment of the invention, in an amount effective to produce a therapeutic effect in a host.

According to a sixth embodiment of the invention, there is provided the adenoviral vector in accordance with the first embodiment of the invention when used in the treatment of disease in a mammal, including a human.

According to a seventh embodiment of the invention, there is provided the adenoviral vector in accordance with the first embodiment of the invention when used in effecting a gene therapy treatment.

According to an eighth embodiment of the invention, there is provided use of the adenoviral vector in accordance with the first embodiment of the invention in the preparation of a medicament for effecting a gene therapy treatment

Detailed Description of the Invention



The adenoviral vectors described herein include several general types or generations, each of which are described below. These vectors include an adenovirus DNA genome containing an adenovirus 5' ITR; an adenovirus 3' ITR; an adenovirus encapsidation signal; at least one DNA sequence encoding a protein or polypeptide of interest; and a promoter controlling the at least one DNA sequence encoding a protein or polypeptide of interest. One generation of adenoviral vectors (Av3 vectors) contain a deletion of all or part of the E1 region and also a deletion of all or a part of the E2 region (preferably all or part of the E2a region). A second generation of adenoviral vectors (Av4 vectors) contain a deletion of all or part of the E1 region and a deletion of all or a part of the E2 region (preferably all or part of the E2a region), and a deletion of all or a part of the E4 region. A third generation of adenoviral vectors (Av5 vectors) contain a deletion of all or a part of the E1 region, and a deletion of all or part of the E4 region. Each of these vectors may or may not contain some part of the E3 region operationally linked to a promoter which controls its expression.

In these vectors, the DNA sequence encoding a protein or polypeptide of interest, which is linked operationally to a promoter controlling its expression is sometimes hereinafter referred to as a transgene. Cell lines containing adenovirus structural genes under the control of an inducible promoter (i) are referred to as iE1 (E1 genes); iE2a (E2a genes); iE1/E2 (E1 and E2 genes); (i)E1/E4 (E1 and E4 genes); or iE1/E2a/E4 (E1, E2, and E4 genes).

In one embodiment, there is provided an adenoviral vector which includes an adenoviral 5' ITR; an adenoviral 3' ITR; an adenoviral encapsidation signal; at least one DNA sequence encoding a protein or polypeptide of interest; and a promoter controlling the DNA sequence(s) encoding a protein(s) or polypeptide(s) of interest. The adenoviral

vector is free of all or a portion of the adenoviral E1 (preferably at least all or a portion of E1a) and E4 DNA sequences. In a preferred embodiment, the adenoviral vector also is free of all or a portion of adenoviral E1b DNA sequence. Such a vector is sometimes referred to as an adenoviral E1E4' vector.

The term "portion" as used herein means that a portion of the DNA sequence of a region (e.g., E1, E2, E3, and/or E4) of the adenoviral genome is removed such that the function of such region is eliminated or impaired. For example, a portion of the DNA sequence of a region of the adenoviral genome is removed such that one or more proteins normally encoded by such region are not expressed, or are expressed as a structure which eliminates or impairs the function of such proteins.

The determination of the amount of the DNA sequence of a region which is to be removed is determined by routine experimentation by one skilled in the art given the teachings herein. Preferably, all or substantially all of a coding region is removed.

In one preferred embodiment, at least open reading frame 6 (ORF 6) of the E4 DNA sequence is deleted. In another embodiment, at least open reading frames 3 and 6 of the E4 DNA sequence are deleted.

In another embodiment, there is provided an adenoviral vector which includes an adenoviral 5' ITR; an adenoviral 3' ITR; an adenoviral encapsidation signal; at least one DNA sequence encoding a protein or polypeptide of interest; and a promoter controlling the DNA sequence(s) encoding a protein(s) or polypeptide(s) of interest. The adenoviral vector is free of all or a portion of the adenoviral E1 and all or a portion of E2 (preferably at least all or a portion of E2a) DNA sequences. In a preferred embodiment, the adenoviral vector also is free of all or a portion of the

adenoviral E1b DNA sequence. Such vector is sometimes referred to as an adenoviral E1'E2' vector.

In another embodiment, all or a portion of the E2b DNA sequence is deleted. In yet another embodiment, all or a portion of the E2a and E2b DNA sequences are deleted.

In another preferred embodiment, there is provided an adenoviral vector which includes an adenoviral 5' ITR; an adenoviral 3' ITR; an adenoviral encapsidation signal; at least one DNA sequence encoding a protein or polypeptide of interest; and a promoter controlling the DNA sequence(s) encoding the protein(s) or polypeptide(s) of interest. The adenoviral vector is free of all or a portion of the adenoviral E1 (including E1a and E1b), E2, and E4 DNA sequences. Such vector is sometimes referred to as an adenoviral E1'E2'E4' vector. Preferably, such vector is free of at least open reading frame 6 of the E4 DNA sequence.

In one preferred embodiment the vector is free of all or a portion of the E2a DNA sequence. Such vector is sometimes referred to as an adenoviral E1'E2a'E4' vector. In another embodiment, the vector is free of all or a portion of the E2b DNA sequence.

In one embodiment, the adenoviral vectors hereinabove described also include at least a portion of the adenoviral E3 DNA sequence, operationally linked to a promoter which allows expression of E3 region genes in the transduced host cells, and which enables the adenovirus to retain some or all of its immune defense system. The amount of the E3 DNA sequence included in the adenoviral vector is, in general, an amount of the E3 DNA sequence which will enable the adenoviral vector to evade or disable the host's immune response. Preferably, all of the genes of the E3 region are included in the vector, except the gene encoding the 11.6 Kda protein that causes cell lysis.

In another embodiment, the above-mentioned adenoviral vectors do not contain the E3 region genes.

The vectors of the present invention in a preferred embodiment are adenoviral particles wherein the genetic material contained in the virus lacks the genetic material which is specified as having been deleted.

Thus, in accordance with a preferred embodiment of the invention, the genome of the adenoviral vector contains the early regions (E1, E2, E3 and E4) and the major late regions to the extent necessary not to impair the function of the proteins encoded thereby, except for all or a portion of the regions which are specified as having been deleted from the genetic material of the adenovirus. Thus, if an adenoviral vector is defined as being free of all or a portion of E1 and E2, then such vector would contain the E3 and E4 regions to the extent necessary not to disrupt or substantially impair the function of the protein encoded thereby. All other regions, including the major late regions and minor transcriptional units, would also be present to the extent necessary not to disrupt or substantially impair the function of the proteins encoded thereby.

The adenoviral vector may be derived from any known adenovirus serotype, including, but not limited to, Adenovirus 2, Adenovirus 3, and Adenovirus 5.

The adenoviral vector, in general, also includes DNA encoding at least one therapeutic agent. The term "therapeutic" is used in a generic sense and includes treating agents, prophylactic agents, and replacement agents.

DNA sequences encoding therapeutic agents which may be placed into the adenoviral vector include, but are not limited to, the CFTR gene; genes encoding interferons such as Interferon- α , Interferon- β , and Interferon- γ ; genes encoding interleukins such as IL-1, IL-1 β , and Interleukins 2 through 14; genes encoding GM-CSF; genes encoding adenosine deaminase, or ADA; genes which encode cellular growth

factors, such as lymphokines, which are growth factors for lymphocytes; genes encoding clotting factors such as Factor VIII and Factor IX; T-cell receptors; the LDL receptor, ApoE, ApoC, ApoAI and other genes involved in cholesterol transport and metabolism; the alpha-1 antitrypsin (α 1AT) gene; lung surfactant protein genes, such as the SP-A, SP-B, and SP-C genes; the insulin gene, negative selective markers or "suicide" genes, such as viral thymidine kinase genes, such as the Herpes Simplex Virus thymidine kinase gene, the cytomegalovirus virus thymidine kinase gene, and the varicella-zoster virus thymidine kinase gene; Fc receptors for antigen-binding domains of antibodies, and antisense sequences which inhibit viral replication, such as antisense sequences which inhibit replication of hepatitis B or hepatitis non-A non-B virus.

The DNA sequence (or transgene) which encodes the therapeutic agent may be genomic DNA or may be a cDNA sequence. The DNA sequence also may be the native DNA sequence or an allelic variant thereof. The term "allelic variant" as used herein means that the allelic variant is an alternative form of the native DNA sequence which may have a substitution, deletion, or addition of one or more nucleotides, which does not alter substantially the function of the encoded protein or polypeptide or fragment or derivative thereof. In one embodiment, the DNA sequence may further include a leader sequence or portion thereof, a secretory signal or portion thereof and/or may further include a trailer sequence or portion thereof.

The DNA sequence encoding at least one therapeutic agent is under the control of a suitable promoter. Suitable promoters which may be employed include, but are not limited to, adenoviral promoters, such as the adenoviral major late promoter; or heterologous promoters, such as the cytomegalovirus (CMV) promoter; the Rous Sarcoma Virus (RSV) promoter; inducible promoters, such as the MMT promoter, the

metallothionein promoter; heat shock promoters; the albumin promoter; and the ApoAI promoter. It is to be understood, however, that the scope of the present invention is not to be limited to specific foreign genes or promoters.

Such vectors may be assembled by direct in vitro ligation from combinations of plasmids containing portions of modified or unmodified virus genome or plasmids and fragments derived directly from a linear adenoviral genome, such as the Adenovirus 5 genome (ATCC No. VR-5) or Adenovirus 5 derived viruses containing mutations or deletions as described herein.

In another alternative, the vectors can be assembled by homologous recombination, within a eukaryotic cell, between a plasmid clone containing a portion of the adenoviral genome (such as the Adenovirus 5 genome or the adenovirus 5 E3-mutant Ad dl327 (Thimmapaya, et al., Cell, Vol. 31, pg. 543 (1983)) with the desired modifications, and a second plasmid (such as, for example pAvS6, as shown in Figure 24), containing the left adenoviral ITR, an E1 region deletion, and the desired trans gene. Alternatively, homologous recombination may be carried out between a plasmid clone and a fragment derived directly from a linear adenovirus (such as Adenovirus 5, or Ad dl327 or an Adenovirus 5 derived virus containing mutations or deletions as described herein) genome.

The vector then is transfected into a cell line capable of complementing the function of any essential genes deleted from the viral vector, in order to generate infectious viral particles. The cell line in general is a cell line which is infectable and able to support adenovirus or adenoviral vector growth, provide for continued virus production in the presence of glucocorticoid hormones, and is responsive to glucocorticoid hormones (i.e., the cell line is capable of expressing a glucocorticoid hormone receptor). Cell lines which may be transfected with the essential adenoviral genes,

and thus may be employed for generating the infectious adenoviral particles include, but are not limited to, the A549, KB, and HEp-2 cell lines.

Because the expression of some viral genes may be toxic to cells, the E1 region, as well as the E2a, E2b, and/or E4 regions, may be under the control of an inducible promoter. Such inducible may include, but are not limited to, the mouse mammary tumor virus (MMTV) promoter (Archer, et al., Science, Vol. 255, pgs. 1573-1576 (March 20, 1992)); the synthetic minimal glucocorticoid response element promoter GRE5 (Mader, et al., Proc. Nat. Acad. Sci., Vol. 90, pgs. 5603-5607 (June 1993)); or the tetracycline-responsive promoters (Gossen, et al., Proc. Nat. Acad. Sci., Vol. 89, pgs. 5547-5551 (June 1992)). In another alternative, the E1 region is under the control of an inducible promoter, and the E2a, E2b, and/or E4 regions are under the control of their native promoters. In such alternative, the native promoters are transactivated by expression of the E1 region.

In one embodiment, the cell line includes the entire adenoviral E4 region with its native promoter region, and the E1a region or the entire E1 region (including the E1a and E1b regions) under the control of a regulatable or inducible promoter, such as, for example, the mouse mammary tumor virus (or MMTV) promoter, which is a hormone inducible promoter, or other such promoters containing glucocorticoid responsive elements (GRE's) for transcriptional control. In another embodiment, the E4 DNA sequence also is expressed from a regulatable promoter, such as the MMTV promoter. The E1 and E4 DNA sequences may be included in one expression vehicle, or may be included in separate expression vehicles. Preferably, the expression vehicles are plasmid vectors which integrate with the genome of the cell line.

In one embodiment, the producer cell line includes a first plasmid which includes the E1a or the entire E1 DNA sequence under the control of an inducible promoter (such as

the MMTV promoter), and a second plasmid including the E4 DNA sequence under the control of its native promoter. In such an embodiment, the producer cell line is transduced with the adenoviral vector which does not include the E1 and E4 DNA sequences. The cells then are exposed to an inducing agent, (such as, for example, dexamethasone when an MMTV promoter is employed), which activates the inducible promoter, such as the MMTV promoter, thereby initiating expression of the E1 DNA. The expression of the E1 DNA provides for transactivation of the E4 promoter, thereby providing for expression of the E4 DNA. The expression of the E1 and E4 DNA thus enables the generation of infectious adenoviral particles.

In another embodiment, the producer cell line includes a first plasmid which includes the E1a or the entire E1 DNA sequence under the control of an inducible promoter (such as the MMTV promoter or a promoter containing a glucocorticoid responsive element), and a second plasmid including the E4 DNA sequence under the control of an inducible promoter (such as the MMTV promoter or a promoter containing a glucocorticoid responsive element). The producer cell line then is transduced with the adenoviral plasmid vector which does not include the E1 and E4 DNA sequences. The cells then are exposed to the inducing agent (such as, for example, dexamethasone), which activates the promoters (such as the MMTV promoters or promoters containing a glucocorticoid responsive element) controlling the E1 and E4 DNA sequences, thereby initiating expression of the E1 and E4 DNA sequences, whereby the expression of such sequences enables the generation of the infectious adenoviral particles. It is to be understood, however, that the inducible or regulatable promoters controlling the E1 and E4 DNA sequences need not be identical.

In another embodiment, an adenoviral vector wherein the E1a or entire E1 DNA sequence, and the E2a DNA sequence, or

E2a and E2b DNA sequences, have been deleted, is transfected into a cell line capable of complementing the function of the E1a or entire E1, and E2a or E2a and E2b DNA sequences, as well as any other essential genes deleted from the viral vector, in order to generate infectious viral particles. In one embodiment, the cell line includes the E1a or entire E1 region under the control of a promoter which may be its native promoter or a regulatable promoter, such as, for example, the mouse mammary tumor virus (or MMTV) promoter, or other such promoters containing glucocorticoid responsive elements (GRE's) for transcriptional control. The cell line also includes the adenoviral E2a region or E2a and E2b regions under the control of its native promoter region, or a regulatable promoter such as those hereinabove described. The E1a or entire E1, and E2a or E2a and E2b DNA sequences, may be included in one expression vehicle, or may be included in separate expression vehicles.

In one embodiment, the producer cell line includes a first plasmid including the E1 DNA sequence under the control of a promoter containing a glucocorticoid responsive element, and a second plasmid including the E2a DNA sequence under the control of the MMTV promoter. The producer cell line is transduced with the adenoviral plasmid vector which does not include the E1 and E2a DNA sequences. The cells then are exposed to a glucocorticoid hormone such as dexamethasone for activation of the E1 promoter and for activation of the MMTV promoter, thereby initiating expression of the E1 and E2a DNA sequences and enabling the generation of infectious adenoviral particles.

In another embodiment, the producer cell line includes a first plasmid including the E1 DNA sequence under the control of an inducible promoter (such as the MMTV promoter or other promoters containing a glucocorticoid responsive element), and a second plasmid including the E2a DNA sequence under the control of its native promoter. Expression of the

E1 and E2a DNA sequences is accomplished by the same approach as carried out with respect to the producer cell line including the E1 DNA sequence under the control of an inducible promoter, and the E4 DNA sequence under the control of its native promoter.

In yet another embodiment, the producer cell line includes a first plasmid including the E1 DNA sequence under the control of the MMTV promoter, and a second plasmid including the E2a DNA sequence under the control of the MMTV promoter. Expression of the E1 and E2a DNA sequences, leading to the generation of infectious adenoviral particles, is accomplished by exposing the cells to dexamethasone, thereby activating the MMTV promoters controlling the E1 and E2a DNA sequences.

In yet another embodiment, an adenoviral vector, wherein the E1, E2a, and E4 DNA sequences have been deleted, is transfected into a cell line which includes the adenoviral E1, E2a, and E4 regions. If the vector also includes a deletion of the E2b DNA sequence, the cell line also will include the E2b region. Each of the E1, E2a, and E4 regions may be under the control of their native promoters, or any or all of the E1, E2a, and E4 regions may be under the control of an inducible or regulatory promoter, such as those hereinabove described. The E1, E2a, and E4 DNA sequences may be included in one expression vehicle, or the E1, E2a, and E4 DNA sequences may each be included in separate expression vehicles, or two of the E1, E2a, and E4 DNA sequences may be included in one expression vehicle, and the other of the E1, E2a, and E4 DNA sequences may be included in another expression vehicle. Expression of the E1, E2a and E4 DNA sequences may be accomplished by employing approaches similar to those hereinabove described.

Uses of the adenoviral vector particles of the present invention include the transduction of eukaryotic cells in vivo or in vitro as part of a gene therapy procedure, and the

transduction of cells in vitro for the in vitro production of desired proteins or therapeutic agents.

In one embodiment, the adenoviral vector particles are administered in vivo in an amount effective to provide a therapeutic effect in a host.

In one embodiment, the vector may be administered in an amount of from 1 plaque forming unit to about 10^{14} plaque forming units, preferably from about 10^6 plaque forming units to about 10^{13} plaque forming units. The host may be a mammalian host, including human or non-human primate hosts.

The infectious adenoviral vector particles are administered to the lung when a disease or disorder of the lung (such as, for example, cystic fibrosis) is to be treated. Such administration may be, for example, by aerosolized inhalation or bronchoscopic instillation, or via intranasal or intratracheal instillation.

In another embodiment, the infectious adenoviral vector particles are administered systemically, such as, for example, by intravenous administration (such as, for example, portal vein injection or peripheral vein injection), intramuscular administration, intraperitoneal administration, intratracheal administration, or intranasal administration.

The adenoviral vector particles may be administered in combination with a pharmaceutically acceptable carrier suitable for administration to a patient. The carrier may be a liquid carrier (for example, a saline solution), or a solid carrier, such as, for example, microcarrier beads.

Cells which may be infected by the infectious adenoviral particles include, but are not limited to, primary cells, such as primary nucleated blood cells, such as leukocytes, granulocytes, monocytes, macrophages, lymphocytes (including T-lymphocytes and B-lymphocytes), totipotent stem cells, and tumor infiltrating lymphocytes (TIL cells); bone marrow cells; endothelial cells; activated endothelial cells; epithelial cells; lung cells; keratinocytes; stem cells;

hepatocytes, including hepatocyte precursor cells; fibroblasts; mesenchymal cells; mesothelial cells; parenchymal cells; vascular smooth muscle cells; brain cells and other neural cells; gut enterocytes; gut stem cells; and myoblasts.

The infected cells are useful in the treatment of a variety of diseases including but not limited to adenosine deaminase deficiency, sickle cell anemia, thalassemia, hemophilia, diabetes, α -antitrypsin deficiency, brain disorders such as Alzheimer's disease, phenylketonuria and other illnesses such as growth disorders and heart diseases, for example, those caused by alterations in the way cholesterol is metabolized and defects of the immune system.

In one embodiment, the adenoviral vector particles may be used to infect lung cells, and such adenoviral vector particles may include the CFTR gene, which is useful in the treatment of cystic fibrosis. In another embodiment, the adenoviral vector may include a gene(s) encoding a lung surfactant protein, such as SP-A, SP-B, or SP-C, whereby the adenoviral vector is employed to treat lung surfactant protein deficiency states.

In another embodiment, the adenoviral vector particles may be used to infect liver cells, and such adenoviral vector particles may include gene(s) encoding clotting factor(s), such as Factor VIII and Factor IX, which are useful in the treatment of hemophilia.

In another embodiment, the adenoviral vector particles may be used to infect liver cells, and such adenoviral vector particles may include gene(s) encoding polypeptides or proteins which are useful in prevention and therapy of an acquired or an inherited defect in hepatocyte (liver) function. For example, they can be used to correct an inherited deficiency of the low density lipoprotein (LDL) receptor.

In another embodiment, the adenoviral particles may be used to infect liver cells, whereby the adenoviral particles include a gene encoding a therapeutic agent employed to treat acquired infectious diseases, such as diseases resulting from viral infection. For example, the infectious adenoviral particles may be employed to treat viral hepatitis, particularly hepatitis B or non-A non-B hepatitis. For example, an infectious adenoviral particle containing a gene encoding an anti-sense gene could be employed to infect liver cells to inhibit viral replication. In this case, the infectious adenoviral particle, which includes a vector including a structural hepatitis gene in the reverse or opposite orientation, would be introduced into liver cells, resulting in production in the infected liver cells of an anti-sense gene capable of inactivating the hepatitis virus or its RNA transcripts. Alternatively, the liver cells may be infected with an infectious adenoviral particle which includes a gene which encodes a protein, such as, for example, α -interferon, which may confer resistance to the hepatitis virus.

In yet another embodiment, an adenoviral vector in accordance with the present invention may include a negative selective marker, or "suicide" gene, such as the Herpes Simplex Virus thymidine kinase (TK) gene. Such a vector may be employed in the treatment of tumors, including cancerous and non-malignant tumors, by administering the adenoviral vector to a patient, such as, for example, by direct injection of the adenoviral vector into the tumor, whereby the adenoviral vector transduces the tumor cells. After the cells are transduced with the adenoviral vector, an interaction agent, such as, for example, ganciclovir, is administered to the patient, whereby the transduced tumor cells are killed.

In another embodiment, the viral particles, which include at least one DNA sequence encoding a therapeutic

agent, may be administered to an animal in order to use such animal as a model for studying a disease or disorder and the treatment thereof. For example, an adenoviral vector containing a DNA sequence encoding a therapeutic agent may be given to an animal which is deficient in such therapeutic agent. Subsequent to the administration of such vector containing the DNA sequence encoding the therapeutic agent, the animal is evaluated for expression of such therapeutic agent. From the results of such a study, one then may determine how such adenoviral vectors may be administered to human patients for the treatment of the disease or disorder associated with the deficiency of the therapeutic agent.

In another embodiment, the adenoviral vector particles may be employed to infect eukaryotic cells in vitro. The eukaryotic cells may be those as hereinabove described. Such eukaryotic cells then may be administered to a host as part of a gene therapy procedure in amounts effective to produce a therapeutic effect in a host.

Alternatively, the vector particles include a gene encoding a desired protein or therapeutic agent may be employed to infect a desired cell line in vitro, whereby the infected cells produce a desired protein or therapeutic agent in vitro.

EXAMPLES

The invention now will be described with respect to the following examples; however, the scope of the present invention is not intended to be limited thereby.

Example 1Development of Cell Lines for Complementation
of E1/E2a or E1/E4 VectorsConstruction of plasmid having Adenovirus 5 E1 sequence.

The Adenovirus 5 genome was digested with ScaI enzyme, separated on an agarose gel, and the 6,095 bp fragment comprising the left end of the virus genome was isolated. The complete Adenovirus 5 genome is registered as Genbank accession #M73260, incorporated herein by reference, and the virus is available from the American Type Culture Collection, Rockville, Maryland, U.S.A., under accession number VR-5. The ScaI 6,095 bp fragment was digested further with ClaI at bp 917 and BglII at bp 3,328. The resulting 2,411 bp ClaI to BglII fragment was purified from an agarose gel and ligated into the superlinker shuttle plasmid pSE280 (Invitrogen, San Diego, CA), which was digested with ClaI and BglII, to form pSE280-E. (Figure 1).

Polymerase chain reaction (PCR) was performed to synthesize DNA encoding an XhoI and SalI restriction site contiguous with Adenovirus 5 DNA bp 552 through 924. The primers which were employed were as follows:

5' end, Ad5 bp 552-585:

5'-GTCACTCGAGGACTCGGTC-GACTGAAAATGAGACATATTATCTGCCACGGACC-3'

3' end, Ad5 bp 922-891:

5'-CGAGATCGATCACCTCCGGTACAAGGTTTGGCATAG-3'

This amplified DNA fragment (sometimes hereinafter referred to as Fragment A) then was digested with XhoI and ClaI, which cleaves at the native ClaI site (bp 917), and ligated to the XhoI and ClaI sites of pSE280-E, thus reconstituting the 5' end of the E1 region beginning 8 bp upstream of the ATG codon.

PCR then was performed to amplify Adenovirus 5 DNA from bp 3,323 through 4,090 contiguous with an EcoRI restriction site. The primers which were employed were as follows:

5' end, Ad5 bp 3323-3360:

5' -CATGAAGATCTGGAAGGTGCTGAGGTACGATGAGACC-3'

3' end, Ad5 bp 4090-4060:

5' -GCGACTTAAGCAGTCAGCTG-AGACAGCAAGACACTTGCTTGATCCAAATCC-3'

This amplified DNA fragment (sometimes hereinafter referred to as Fragment B) was digested with BglII, thereby cutting at the Adenovirus 5 BglII site (bp 3,382) and EcoRI, and ligated to the BglII and EcoRI sites of pSE280-AE to reconstruct the complete E1a and E1b region from Adenovirus 5 bp 552 through 4,090. The resulting plasmid is referred to as pSE280-E1 (Figure 1).

The intact E1a/E1b region was excised from pSE280-E1 by cutting with EcoRI, blunting with Klenow and cutting with SalI. The 3,567 bp fragment was purified from an agarose gel and ligated to the expression plasmid pMAMneo (Clontech, Palo Alto, CA), which was prepared similarly by cutting with XhoI at bp 3,405 of pMAMneo Luc (Figure 2), blunting with Klenow, and cutting with SalI at bp 1,465. The 8,399 bp fragment was gel purified, phosphatased, and ligated to the E1a/E1b fragment hereinabove described to form pMAMneo-E1. (Figure 3.)

Bacterial transformants containing the final pMAMneo-E1 construct were identified. Plasmid DNA was prepared and purified by banding in CsTFA. Circular plasmid DNA was linearized at the XmnI site within the ampicillin resistance gene of pMAMneo-E1, and purified further by phenol/chloroform extraction and ethanol precipitation prior to use for transfection of cells.

An alternative construction containing the intact E1a/b region under the control of the synthetic promoter GRE5 was prepared as follows. The intact E1a/b region was excised from pSE280-E1, which was modified previously to contain a BamHI site 3' to the E1 gene, by digesting with XhoI and BamHI. The XhoI to BamHI fragment containing the E1a/b fragment was cloned into the unique XhoI and BamHI sites of

pGRE5-2/EBV (Figure 4, U.S. Biochemicals, Cleveland, Ohio) to form pGRE5-E1 (Figure 5).

Construction of plasmid including Adenovirus 5 E2a sequence.

The Adenovirus 5 genome was digested with BamHI and SpeI, which cut at bp 21,562 and 27,080, respectively. Fragments were separated on an agarose gel and the 5,518 bp BamHI to SpeI fragment was isolated. The 5,518 bp BamHI to SpeI fragment was digested further with SmaI, which cuts at bp 23,912. The resulting 2,350 bp BamHI to SmaI fragment was purified from an agarose gel, and ligated into the superlinker shuttle plasmid pSE280, and digested with BamHI and SmaI to form pSE280-E2 BamHI-SmaI (Figure 6).

PCR then was performed to amplify Adenovirus 5 DNA from the SmaI site at bp 23,912 through 24,730 contiguous with NheI and EcoRI restriction sites. The primers which were employed were as follows:

5' end, Ad5 bp 24,732-24,708:

5'-CACGAATTCGTCAGCGCTTCTCGTCGCGTCCAAGACCC-3'

3' end, Ad5 bp 23,912-23,934:

5'-CACCCCGGGGAGGCGGGCGGCGACGGGGACGGG-3'

This amplified DNA fragment was digested with SmaI and EcoRI, and ligated to the SmaI and EcoRI sites of pSE280-E2 Bam-Sma to reconstruct the complete E2a region from Ad5 bp 24,730 through 21,562. The resulting construct is pSE280-E2a. (Figure 6.)

In order to convert the BamHI site at the 3' end of E2a to a SalI site, the E2a region was excised from pSE280-E2a by cutting with BamHI and NheI, and recloned into the unique BamHI and NheI sites of pSE280. (Figure 6.) Subsequently, the E2a region was excised from this construction with NheI and SalI in order to clone into the NheI and SalI sites of the pMAMneo multiple cloning site in a 5' to 3' orientation, respectively. The resulting construct is pMAMneo E2a. (Figure 6).

Bacterial transformants containing the final pMAMneo-E2a were identified. Plasmid DNA was prepared and purified by banding in CsTFA. Circular plasmid DNA was linearized at the XmnI site within the ampicillin resistance gene of pMAMneo-E2a, and further purified by the phenol/chloroform extraction and ethanol precipitation prior to use for transfection of cells. Alternatively, the plasmid was linearized with BclIII, which cuts in the reading frame of the neo^R gene, thereby inactivating it. This form of the plasmid was used where co-transfection with an alternative selectable marker was required.

Construction of plasmid including Adenovirus 5 ITR/E4 region.

The Adenovirus 5 genome was digested with SpeI, which cuts at bp 27,082, and the two fragments separated on an agarose gel. The 8,853 bp fragment comprising the right end of Adenovirus 5 was isolated.

The 8,853 bp right end fragment was digested further with StuI at bp 31,956 and Eco47-III at bp 35,503. Fragments were separated on an agarose gel and the 3,547 bp StuI to Eco47-III fragment was isolated. This fragment was ligated to the superlinker shuttle plasmid pSE380 (Invitrogen) (Figure 7), digested with StuI and Eco47-III to construct pSE380-E4 (Figure 8).

PCR was performed to amplify Adenovirus 5 DNA from bp 35,499 through the right ITR ending at bp 35,935, and contiguous with a BamHI restriction site. The PCR primers which were employed were as follows:

5' end, Ad5 bp 35,935-35,908:

5'-GTGGGATCCATCATCAATAATATACCTTATTTTGGGA-3'

3' end, Ad5 bp 35,503-35,536:

5'-ATACAGCGCTTCCACAGCGGCAGCCATAACAGTC-3'

This amplified DNA was digested with BamHI and Eco47-III, which cuts at the Adenovirus 5 Eco47-III site bp 35,503, and ligated to the unique BamHI and Eco47-III sites of pSE380-E4 to form pSE380-ITR/E4. (Figure 8.)

Construction of a plasmid containing the E4 region
under the control of an inducible promoter.

A plasmid expressing all of the adenovirus 5 E4 open reading frames under the control of the glucocorticoid inducible GRE5 promoter, and containing a puromycin resistance gene under the control of the control of the SV40 promoter was constructed as follows.

The construct pSE380-E4 (Figure 8) was cut with Eco47-3 and BamHI and ligated to a synthetic oligonucleotide of 33 bp, which includes the Eco47-3 site at Adenovirus 5 bp 35,503 through the E4 ORF1 ATG at bp 35,522. The resulting construct, pSE380E4-ATG (Figure 9) contains all E4 open reading frames without a promoter. The E4 ORF's were excised from pSE380E4/ATG as an XhoI to BamHI fragment and ligated to the XhoI and BglIII sites within the multiple cloning site of the expression shuttle plasmid pSE380GRE5/SV40Puro^R, to generate pGRE5/E4Puro (Figure 9). The expression shuttle plasmid pSE380GRE5/SV40Puro^R was constructed from pSE380 (Figure 7), the GRE5 promoter excised from pGRE5/EBV (Figure 4), and a puromycin resistance gene.

Transfection and selection of cells.

In general, this process involved the sequential introduction, by calcium phosphate precipitation, or other means of DNA delivery, of two plasmid constructions each with a different viral gene, into a single tissue culture cell. The cells were transfected with a first construct and selected for expression of the associated drug resistance gene to establish stable integrants. Individual cell clones were established and assayed for function of the introduced viral gene. Appropriate candidate clones then were transfected with a second construct including a second viral gene and a second selectable marker. Transfected cells then were selected to establish stable integrants of the second construct, and cell clones were established. Cell clones were assayed for functional expression of both viral genes.

In order to determine the most suitable cell lines for the above-mentioned transfections, sequential transfections and selections were carried out with the following parental cell types:

- A549 (ATCC Accession No. CCL-185);
- Hep-2 (ATCC Accession No. CCL-23); or
- KB (ATCC Accession No. CCL-17).

Appropriate selection conditions were established for both G418 and hygromycin B for all three cell lines by standard kill curve determination.

Transfection of cell lines with plasmids
including E1 and E2a regions.

pMAMneo-E2a was digested with BclII to linearize the plasmid within the neo^R reading frame and inactivate the gene. The cell lines hereinabove described were co-transfected with the linear pMAMneo^R-E2a and a selectable marker plasmid consisting of a eukaryotic expression cassette containing an SV40 promoter, a hygromycin resistance gene, and a polyadenylation signal cloned into the multiple cloning site of a pTZ18R (Figure 10), at a 10:1 molar ratio. 48 hours after transfection, the cells were placed under hygromycin selection and maintained in selection until drug resistant colonies arose. The clones were isolated and screened for E2a expression by staining for E2a protein with a polyclonal antiserum, and visualizing by immunofluorescence. E2a function was screened by complementation of the temperature-sensitive mutant Ad5ts125 virus which contains a temperature-sensitive mutation in the E2a gene. (Van Der Vliet, et al., *J. Virology*, Vol. 15, pgs. 348-354 (1975)). Positive clones were identified and transfected with pMAMneoE1 linearized with XmnI within the ampicillin resistance gene. The cells were selected for G418 resistance. G418-resistant colonies were screened for E1 expression by staining with a monoclonal antibody for the E1 protein (Oncogene Sciences, Uniondale, N.Y.). E1 function was assayed by ability to complement an

E1-deleted vector such as pAvS6 (Figure 20) described hereinbelow.

In a preferred alternative, pMAMNeo-E2a was linearized with XmnI with the Amp^R gene, introduced into cells by transfection, and cells were selected for stable integration of this plasmid by G418 selection. Clones expressing the E2a gene were identified and used for transfection with the 7 kb EcoRV to XmnI fragment from pGRE5-E1 (Figure 5), which contains the GRE5 promoted E1a/b region plus the hygromycin^R gene. Cells were selected for hygromycin resistance and assayed for both E1a/b and E2a expression.

Transfection of cell lines with plasmids including E1 and E4 regions.

Circular plasmid pSE380-E4 was co-transfected into the cell lines hereinabove described with a hygromycin resistance plasmid as described above at a 10:1 molar ratio, 48 hours after transfection, the cells were placed under hygromycin selection and maintained in selection until drug resistant colonies arose. The clones then were isolated and screened for E4 function. Specifically, clones were tested for their ability to complement the Adenovirus 5 mutant dl 1011 (Bridge, et al. *Virology*, Vol. 193, pgs. 794-801 (1993)), which contains a deletion of all E4 open reading frames, and to produce infectious virus of the E4 genotype. Positive clones were identified and transfected with pMAMneoE1 linearized with XmnI within the ampicillin resistance gene. The cells then were selected for G418 resistance. G418-resistant colonies then were screened for E1 function.

Transfection of cells containing the inducible E1 and inducible E2a plasmids with an inducible E4 expression plasmid.

In the preferred alternative described above for the generation of cells containing pMAM-neo/E2a and pGRE5-E1, clones were identified that inducibly express both viral genes. These cell lines are modified further by transfection

with the pGRE5/E4/SV40Puro' plasmid (Figure 9) and selection for puromycin resistant colonies. Cell clones are selected, expanded, and analyzed for inducible E4 function by assaying for dexamethasone-dependent complementation of the E4 deleted virus Ad5dl1011. (Bridge, et al., *Virology*, Vol. 193, pgs. 794-801 (1993)). In another alternative, the E4 gene would be operationally linked to a tetracycline-inducible promoters.

Example 2

Development of Vectors with Deletions of E1/E2a or E1/E4 Intermediates for construction of a vector with E2A deletion

Subcloning of Adenovirus 5 E2 region.

Adenovirus 5 genomic DNA was cut with BamHI (bp 21,562) and SpeI (bp 27,082) restriction enzymes, and the 5,520 bp BamHI to SpeI fragment was isolated from an agarose gel. The 5,520 bp BamHI to SpeI fragment was ligated to the pTZ18R plasmid (Pharmacia, Piscataway, NJ) (Figure 10), which was modified previously to contain an SpeI site at bp 186, to generate plasmid pTZE2A. (Figure 11.)

Deletion of the E2A open reading frame.

pTZE2A was cut with BamHI (bp 8,391) and SmaI (bp 2,350) restriction enzymes, corresponding to bp 21,562 and 23,912 of Adenovirus 5. The 6,041 bp and 2,350 bp BamHI/SmaI fragments were isolated from an agarose gel. The 2,350 bp BamHI/SmaI fragment was digested with DraI restriction enzyme (bp 22,442 of Adenovirus 5), and the 880 bp DraI to BamHI fragment was isolated from an agarose gel. The 880 bp DraI/BamHI fragment was ligated to the 6,041 bp BamHI/SmaI fragment via a cohesive BamHI to BamHI and blunt ended SmaI to DraI ligation, thereby generating plasmid pTZdle2A. (Figure 11.) Such plasmid includes the Adenovirus 5 E2A region in which 1,470 bp of the E2A region, corresponding from the DraI site (bp 22,442) to the SmaI site (bp 23,912) have been deleted.

Subcloning of the Adenovirus 5 E3 region.

The Adenovirus 5 genome was digested with SpeI (at bp 27,082). The 8,853 bp fragment comprising the right end of Adenovirus 5 was isolated. The 8,853 bp right end fragment of Adenovirus 5 was digested with StuI (bp 31,956). The 4,874 bp SpeI/StuI fragment was isolated. This fragment was ligated to the plasmid pSE380 (Invitrogen) which was digested with StuI and SpeI, in order to generate pSE380-E3+. (Figure 12.)

Combining the E3 and E4 regions.

The plasmid SE380-E3+ was digested with SpeI and StuI, and the 4,874 bp fragment was ligated to the pSE380-ITR/E4 plasmid (Figure 8), which was digested with SpeI and StuI, to generate pSE380-E3+E4+. (Figure 13.)

The E3+/E4+ fragment then was excised as an 8,943 bp SpeI to BamHI fragment from pSE380-E3+E4+, and recloned into the SpeI and BamHI sites of pTZ18R, previously modified to remove the XbaI site, to generate pTZE3+E4+. (Figure 13.)

Deletion within the E3 region.

The plasmid pTZE3+E4+ was digested with XbaI, in order to delete 1,878 bp of the E3 region between the XbaI sites at bp 28,592 and 30,470 of the Adenovirus 5 genome, to generate pTZE3E4+. (Figure 14.)

The plasmid pTZE3E4+ was digested with SpeI and BamHI and ligated into the SpeI and BamHI sites of the pSE280 plasmid to form pSE280-E3E4+. The pSE280-E3E4+ plasmid was digested with BamHI, blunted, and recircularized to remove the BamHI site. The E3E4+ containing fragment was removed by restriction digestion with SpeI and SalI and ligated to the pSPORT-1 (Figure 15) (Gibco/BRL, Gaithersburg, MD) plasmid digested with SpeI and SalI, to generate pSPORT1E3E4+. (Figure 14.)

Combining the E2A region with the E3/E4⁺ region.

The plasmid pSPORT-1E3E4⁺ was digested with SpeI and BamHI, and ligated to the BamHI/SpeI fragment from plasmid pTZdlE2A, to generate pSPORT-1E2AE3E4⁺. (Figure 16.)

Construction containing an E2A region deletion and a modified E3 region

In another alternative, the pSPORT1/E2A-E3+E4⁺ (Figure 16) may be modified by inserting an XbaI fragment containing a heterologous promoter, such as SV40, operationally linked to all or a part of the E3 region open reading frames into the unique XbaI site to generate pSPORT1/E2A-E3+E4⁺.

21.

Incorporation of E2AE3E4⁺ regions into a circular, non-infectious Adenovirus 5 plasmid.

Plasmid pSPORT-1E2AE3E4⁺ was digested with BamHI and SalI. The fragment containing the E2AE3E4⁺ sequences was ligated to plasmid pBR322 (Figure 17) (Life Technology, Gaithersburg, MD) digested with BamHI and SalI, to generate pBR322E2AE3E4⁺. (Figure 18.)

The Adenovirus 5 genome was digested with ClaI (bp 917) and BamHI (bp 21,562), and the 20,645 bp fragment was ligated to the plasmid pBR322E2AE3E4⁺ (which also was digested with ClaI and BamHI), to generate pBRAd5E2AE3E4⁺. (Figure 18.)

Intermediates for construction of a vector with an E4 deletion.

The plasmid pSE380-ITR/E4 was digested with BpU1102 (bp 33,129) and Eco47-3 (bp 35,503) to remove all E4 open reading frames, to generate pSE380-E4⁻. (Figure 19.)

The E4 region (StuI to BamHI) of plasmid pSE380-E3+E4⁺ was removed and replaced with the StuI to BamHI fragment from pSE380-E4⁻, in order to incorporate the E4 deletion and generate pSE380-E3+E4⁻. (Figure 19.)

In a preferred alternative, a larger E4 region deletion is made which reduces a 60 amino acid reading frame initiated

from the E4 ORF1 ATG of pSE380E4⁻ to seven amino acids. This preferred modification, referred to as pSE380E4⁻(2) is constructed as shown in Figure 20. pSE380E4⁻ is cut with Bpu 1102 (Adenovirus 5 bp 33,129) and AflII (Adenovirus 5 bp 33,104), blunt ended by filing in 5' overhangs with Klenow, and religating to form pSE380E4⁻(2). This alternative E4 region deletion then is excised as a StuI to BamHI fragment and substituted for the StuI to BamHI fragment in pSE380E3⁺E4⁺ (Figure 13) to generate pSE380E3⁺E4⁻(2), as shown in Figure 20.

As a further modification, the XbaI region between Adenovirus 5 bp 28,592 and 30,470 is deleted from pSE380E3⁺E4⁻(2) in order to generate pSE380E3⁺E4⁻(2), as shown in Figure 21.

In another alternative, the XbaI region between Ad5 bp 28,592 and 30,470 in pSE380E3⁺E4⁻(2); Figure 21, may be replaced with an XbaI fragment containing a heterologous promoter, such as SV40, operationally linked at some or all of the E3 region open reading frames, to create pSE380E3⁺E4⁻(2).

Combining deletions within the E2A, E3, and E4 regions into a single plasmid

An Adenovirus 5 DNA fragment containing both the E3 region deletion and E4 region deletion in tandem is excised from pSE380E3⁺E4⁻(2) by digestion with SpeI (Adenovirus 5 bp 27,082) and SalI (Figure 22). This fragment is substituted for the unique SpeI to SalI fragment in pSPORT1/E2A⁺E3⁺E4⁺ (Figure 16) to form pSPORT1/E2A⁺E3⁺E4⁻(2), as shown in Figure 22.

In another alternative, the unique SpeI to SalI fragment in pSPORT1/E2A⁺E3⁻E4⁺ (Figure 16) may be replaced with the SpeI to SalI fragment excised from pSE380E3⁺E4⁻(2) to create pSPORT1/E2A⁺E3⁺E4⁻(2).

Virus Vector Production

Production of a vector with the genotype E1+E2A⁺E3⁺E4⁺.

The plasmid pSPORT-1E2AE3E4+ is digested with BamHI and Sall, and the fragment containing the E2AE3E4+ sequences is purified from an agarose gel. The unique BamHI site corresponds to the BamHI site at bp 21,562 of Adenovirus 5. The purified fragment is ligated *in vitro* to the left side BamHI fragment of the Adenovirus 5 genome (21,562 bp). The ligation mixture then is transfected into an appropriate cell line capable of complementing the vector E2A deletion for production of an E1+E2E3E4+ Adenovirus 5 vector. (Figure 23.)

Production of a Vector with the genotype E1+E2A-E3+*E4+

In a manner analogous to that described above and shown in Figure 23, the BamHI to Sall fragment may be isolated from pSPORT1/E2A-E3+*E4+ and used in the ligation with the Ad5 21,562 bp left end BamHI fragment to generate an Ad5 virus with the genotype E1+E2A-E3+*E4.

Production of a vector with the genotype E1E2AE3E4+.

The DNA of the E1+E2E3E4+ Adenovirus 5 vector is purified and digested with ClaI. This restriction enzyme cuts the Adenovirus 5 genome at bp 917. The right side fragment is purified and co-transfected with pAvS6 (including a reporter gene or a trans-gene) into a double complementing cell line as capable of providing both E1 and E2A functions in trans. pAvS6 (Figure 24) is a shuttle plasmid which includes an adenoviral 5' ITR, and adenoviral encapsidation signal, an E1a enhancer sequence; a promoter; a tripartite leader sequence, a multiple cloning site for the insertion of foreign genes; a poly A signal; and a DNA segment corresponding to the Adenovirus 5 genome which is no longer than from base 3329 to base 6246 of the genome. pAvS6 is described further in published PCT Application No. WO94/23582, published October 27, 1994. Homologous recombination between the virus DNA fragment and pAvS6 results in a linear virus genome with the genotype E1 (trans gene) E2aE3E4+. (Figure 25.) This vector may be plaque

purified further using a double complementing cell line, E1⁺/E2a⁺.

In another alternative, a vector with the genotype E1'E2A'E3'E4⁺ may be generated by ligating the left ITR through BamHI fragment of a pre-existing E1' vector to the BamHI/SalI fragment of pSPORT-1E2A'E3'E4' (Figure 26) to generate directly an E1' (reporter or trans-gene) E2A'E3'E4⁺ virus which will replicate when transfected into an appropriate complementing cell line. This approach, however, requires that the reporter or trans-gene does not contain a BamHI site.

In yet another alternative (Figure 27), plasmid pBRAD5-E2A'E3'E4⁺ is co-transfected with pAvS6 (containing a reporter gene or a trans-gene), into a double complementing cell line, to generate by homologous recombination an E1' (reporter or trans-gene) E2A'E3'E4⁺ vector. The vector is plaque purified using a double complementing cell line.

As an example of the practice of these methods, a vector with the genotype E1'E2a'E3'E4⁺ was generated using the adenoviral plasmid vector pAvS6nLacZ (described in PCT application No. W095/09654), which contains a nuclear localizing beta-galactosidase cDNA. The resulting vector, Av3nLacZ (Figure 28), was generated by homologous recombination as outlined in Figure 25.

In another alternative, the vector Av3nLacZ can be used as a starting material for the production of other vectors. Av3nLacZ contains two ClaI sites, one within the lacZ coding region and one at the 3' end of lacZ within the polyadenylation signal. (Figure 28). By digesting Av3nLacZ with ClaI and recombining with pAvS6/transgene as described in Figure 25, other Av3-type vectors are made. This approach provides advantages in that no E1⁺ vector backbone is present in the recombination, and new recombinant vectors can be selected as B-gal negative when X-gal is included in the agar overlay during plaque purification.

Production of a vector with the genotype E1-E2A-E3+*E4+

In a manner analogous to that described above and shown in Figure 25, DNA from the virus E1+E2A-E3+*E4+ is digested with ClaI and the right side fragment used to co-transfect with pAVS6/transgene into E1/E2A expressing cells to generate, by homologous recombination, a vector with the genotype E1-E2A-E3+*E4+.

In another alternative, and in a manner analogous to that shown in Figure 26, the left end BamHI fragment from a pre-existing E1- vector may be ligated directly to the BamHI/SalI fragment from a pSPORT1/E2A-E3+*E4+ and transfected into E1/E2A expressing cells to generate a vector with the genotype E1-, transgene, E2A-E3+*E4+.

Production of a vector with the genotype E1+E4'.

A purified Adenovirus 5 fragment from bp 1 to the SpeI site (bp 27,082), containing terminal protein on the 5' end, was ligated to the SpeI/BamHI fragment purified from plasmid pSE380-E3+E4' containing the E4 region deletion. The *in vitro* ligation mixture is transfected into an E4+ cell line to produce an Adenovirus 5 E1+E4' vector. (Figure 29.)

Alternatively, pSE380E3'E4'(2), as shown in Figure 20, is used to generate an E1'E3'E4'(2) virus with the E4 deletion in the same manner as outlined in Figure 29. In another alternative, pSE380E3'E4'(2), as described in Figure 21, is used in the same manner to generate an E1'E3'E4'(2) adenovirus.

Production of a vector with genotype E1'E4'.

The DNA of the Adenovirus 5 E1+E4' genome is purified and digested with ClaI restriction enzyme. The right side fragment is purified and co-transfected with pAvS6 (containing a reporter or trans-gene) into a double complementing cell line expressing E1 and E4. Homologous recombination between the E4' viral fragment and pAvS6 will result in a vector with the genotype E1' (reporter or trans-gene) E2A'E3+E4'. The vector (Figure 30) is plaque purified using a double complementing cell line.

In another alternative, the SpeI/BamHI fragment from SE380-E3+E4' is ligated directly to the left end fragment of a pre-existing E1' vector digested with SpeI to generate an E1' (reporter or trans-gene) E4' vector. (Figure 31.) This approach, however, requires that the reporter or trans-gene does not contain an SpeI site.

In other alternatives, by using either the homologous recombination or the in vitro ligation approaches described above (Figures 30 and 31), and the E1'E3'E4'(2) or E1'E3'E4'(2) viruses hereinabove described, transgene-containing vectors of the types E1'(transgene) E3'E4'(2) or E1'(transgene) E3'E4'(2) are generated.

Example 3

Production of an Adenovirus vector with the genotype E1', E2A', E3', E4'.

Adenovirus vectors with deletions in 3 essential genes (E1, E2A, E4), referred to as triple deletion vectors or AV4 generation vectors are constructed as follows. Using Av3nLacZ as a starting material, AV4nLacZ is generated by either homologous recombination or in vitro ligation. Using AV4nLacZ as a starting material, any other transgene containing Av4 type vector can be constructed.

In one alternative, the unique BamHI to SaliI fragment from pSPORT1/E2A'E3'E4'(2) is isolated and co-transfected with the left end fragment of Av3nLacZ cut at the unique SrfI restriction site (bp 27,098 of AV3nLacZ (Figs. 28, 32) into a triple complementing cell line (as described in Example 1 hereinabove) expressing E1, E2A, and E4 viral genes. Homologous recombination between the these two DNA fragments in the overlapping region between BamHI and SrfI will result in a vector with the genotype E1', nLacZ, E2A', E3', E4' (Fig. 32).

In another alternative, the unique SrfI to SaliI fragment from pSPORT1/E2A'E3'E4'(2) may be isolated and directly ligated to the left end fragment of AV3nLacZ cut with SrfI at bp

27,098 to yield a vector with the genotype E1⁻, nLacZ, E2A⁻, E3⁻, E4⁻. This ligation mixture may then be transfected into the triple complementing cell line (E1⁺, E2A⁺, E4⁺) to produce AV4nLacZ (Fig. 33).

In another alternative, AV4 vectors containing transgenes other than nLacZ are constructed. Purified DNA from AV4nLacZ is digested with ClaI (See Fig. 34), and the right end viral fragment is purified. This fragment is co-transfected with the desired pAVS6/transgene construct into triple complementing cells (E1⁺, E2A⁺, E4⁺) and by homologous recombination to yield an AV4 type vector with the genotype E1⁻, transgene, E2A⁻, E3⁻, E4⁻ (Fig. 34).

Production of an Adenovirus vector with the
genotype E1-E2A-E3+*E4-

In one alternative, and in a manner analogous to the process shown in Figure 32, a unique BamHI/SalI fragment from pSPORT1/E2A-E3+*E4-(2) may be isolated and co-transfected with the left end fragment of AV3nLacZ cut at the unique SrfI restriction site into cells expressing E1, E2A, and E4 in order to generate, by homologous recombination, a vector with the genotype E1⁻, nLacZ, E2A-E3+*E4(2) or AV4nLacZE3+*.

In another alternative, and in a manner analogous to the process shown in Figure 33, the unique SrfI to SalI fragment from pSPORT1/E2A-E3+*E4-(2) may be isolated and used to ligate directly to the left end fragment of AV3nLacZ cut with SrfI. The ligation product is then transfected into cells expressing E1, E2A, and E4 to generate a vector with the genotype E1⁻, nLacZ, E2A-E3+*E4-(2), or AV4nLacZE3+*.

In another alternative, AV4 vectors containing a transgene other than nLacZ and containing the modified E3+* region can be generated in a fashion analogous to that shown in Figure 34. AV4nLacZE3+* is cut with ClaI and co-transfected with pAV6/transgene into cells expressing E1, E2A, and E4 to generate a vector with the genotype E1⁻, transgene, E2A-E3+*E4-(2).

Example 4Development of Recombinant Adenovirus Vectors
with Deletions of E1/E2a, or E1/E4 or E1/E2a/E4
which express the normal human CFTR cDNA.

pAvS6 (Figure 24) was linearized with EcoRV. The normal human CFTR cDNA sequence (nucleotides 75 to 4,725; for numbering see Gen Bank accession number M28668) was removed from plasmid pBQ4-7 (Figure 35) by PstI digestion followed by blunting of the CFTR cDNA ends with T4 polymerase (pBQ4-7 was provided by L.-C.Tsui, the Hospital for Sick Children, Toronto, Canada.) This CFTR cDNA was then inserted into the linearized pAvS6 plasmid so as to create an operational linkage between the RSV promoter and the 5' end of the coding sequence of the CFTR cDNA. The resulting plasmid pAvS6 CFTR (Figure 35) was linearized by digestion with KpnI and cotransfected into E1/E2a, E1/E4 or E1/E2a/E4 expressing cells along with the large ClaI fragment of Av3LacZ for E1/E2, Av5LacZ for E1/E2/E4, or the large ClaI fragment from Av4nLacZ, respectively, as described above.

iE1/E2a cells cotransfected as described above were then overlaid with agent and cultured in a humidified atmosphere containing 5% CO₂ at 37°C until formation of virus plaques. Plaques were picked and the recombinant adenovirus vectors further plaque-purified, amplified and titered as previously described (Rosenfeld, et al., Cell, Vol. 68, pgs. 143-155 (1992)). Adenoviral vectors are evaluated for deletion of Ad genes E1/E2a, E1/E4 or E1/E2/E4 and inclusion of part or all of the normal human CFTR cDNA as previously described (Mittereder, et al., Human Gene Therapy, Vol. 5, pgs. 717-729 (1994)). The ability of such CFTR expressing adenovirus vectors to correct the Cl⁻ secretory defect of CF epithelial cell lines was tested as previously described. (Mittereder, et al., 1994).

Example 5Demonstration that E1/E2a-deleted vectors have reduced

expression of adenoviral late gene products.

This example demonstrates that third generation vectors which harbor deletions in all or part of E1/E2a with or without deletions of E3 region sequences have reduced potential for elicitation of a host immune response. The expression of hexon gene was measured by metabolic labeling. Further, this expression was compared among a first generation vector (e.g., E1/E3 deleted), a second generation vector (e.g., E1 deleted containing a temperature sensitive mutation in the E2a gene (Englehardt, et al., Proc. Nat. Acad. Sci., Vol. 91, pgs. 6196-6200 (1994)) and the third generation vector described above.

To evaluate the performance of these vectors with regard to the decrease in late gene expression due to E2a deletion, A549 cells were infected with Av1LacZ4 (50-500 iu/cell) Av2Luc1, which is an E1 deleted vector containing a temperature sensitive mutation in the E2a gene, and a luciferase gene. (50-500 iu/cell). or Av3LacZ1 (500-3000 in/cell) and cultured in a humidified atmosphere with 5% CO₂ at 37°C. As controls, either iE1/E2a cells or 293 cells (expressing the inducible E1 and E2a regions of Ad5) were infected with Av1LacZ4, Av2Luc1 or Av3LacZ1 at an approximate multiplicity of infection (M.O.I.) of 10 infectious units (iu) per cell. Media was then changed to methionine-free DMEM containing ³⁵S-Met (Mittereder, et al., 1994) and cultured for an additional 24 hours. Metabolically labelled cells were then washed in phosphate buffered saline, lysed and then scraped into 800 µl of Ripa buffer containing antiproteases (PMSF, leupeptide and proteinase). After thorough mixing to homogenize the cells, ³⁵S-Met incorporation into labeled protein was quantified by routine trichloroacetate precipitation. Aliquots of each incubation containing 3x10⁶ cpm were immunoprecipitated using anti-adenovirus 5 hexon antibody and evaluated using SDS-page as previously described (Mittereder, et al., Human Gene Therapy,

5:717-729, 1994). The results show that, at 37°C, normal body temperature, Av3LacZ1 demonstrated markedly reduced hexon gene expression in A549 cells even at a high MOI (Figure 36) and 293 cells (Figure 37, lanes 6-8) than did either Av1LacZ4 or Av2Luc1. As a control, all three vectors express similar amounts of hexon in E1/E2a expressing cells which complement the various adenoviral gene deletions within the vector (Figure 36, lanes 1-3). This demonstrates that the third generation vectors have improved (decreased) expression of adenoviral backbone genes.

Example 6

Demonstration that E1/E2a-deleted vectors have reduced replication of the adenoviral DNA genome.

In order to demonstrate that third generation (E1/E2a) vectors with or without deletions of the E3 region sequences have improved characteristics with respect to residual viral DNA replication, metabolic labeling of vector infected cells with ³²P was conducted. These experiments were carried out in a manner analogous to that described in Example 5 above. To evaluate the replication defect of these vectors, 293 and iE1/E2 cells were infected with Av1LacZ4, Av2Luc1 or Av3LacZ1 at approximately 10 infectious units per cell and cultured as above. PO₄-free media containing ³²P-orthophosphate and cultured for an additional 8 hours. Cells were then washed in phosphate buffered saline then lysed in 0.8 ml of Hirt solution. Viral DNA was purified, digested with XbaI restriction enzyme and subjected to a agarose gel electrophoresis and autoradiography as previously described. (Mittereder, et al., 1994).

The result demonstrate the Av3LacZ1 undergoes significantly less replication than Av2Luc1 or Av1Luc1 (Figure 38). Thus, third generation adenoviral vectors have improved function in relation to adenovirus vector DNA replication.

The disclosure of all patents, publications, (including published patent applications), and database accession numbers and depository accession numbers referenced in this specification are specifically incorporated herein by reference in their entirety to the same extent as if each such individual patent, publication, and database accession number, and depository accession number were specifically and individually indicated to be incorporated by reference.

It is to be understood, however, that the scope of the present invention is not to be limited to the specific embodiments described above. The invention may be practiced other than as particularly described and still be within the scope of the accompanying claims.

The claims defining the invention are as follows:

1. An adenoviral vector comprising a modified adenovirus genome including an adenoviral 5'ITR, an adenoviral 3'ITR, an adenoviral encapsidation signal, DNA encoding a heterologous protein or polypeptide, and a promoter controlling the expression of said DNA encoding a heterologous protein or polypeptide, wherein at least a portion of each of the E1 and E4 DNA sequence has been deleted to eliminate the function of each of the E1 and E4 early proteins, at least a portion of at least one of the E2a and E2b DNA sequences has been deleted to eliminate the function of at least one of the E2a and E2b early proteins, and said vector retains at least a portion of the adenoviral protein function.
2. The vector of Claim 1 wherein at least a portion of the E2a DNA sequence has been deleted to eliminate the function of the E2a early protein, and wherein said vector retains the function of the E2b early protein.
3. The vector of claim 1 or 2, wherein the adenoviral protein function is E3 early protein function.
4. The vector of claim 1 or 2, wherein the adenoviral protein function is major late protein function.
5. A stable cell for complementing adenoviral early protein functions for use in the production of adenoviral vectors, comprising: a stable cell, including a first DNA sequence encoding the adenoviral E1 function, said first DNA sequence being under the control of a first inducible promoter; a second DNA sequence encoding the adenoviral E2 function, said second DNA sequence being under the control of a second inducible promoter; and a third DNA sequence encoding the adenoviral E4 function, said third DNA sequence being under the control of a third inducible promoter, said first, second, and third inducible promoters being the same or different.
6. The stable cell of claim 5, wherein the second DNA sequence encoding the adenoviral E2 function is a DNA sequence encoding the adenoviral E2a function.
7. The cell of Claim 5 or 6 wherein at least one of said inducible promoters is a promoter containing a glucocorticoid responsive element.
8. The cell of Claim 7 wherein said inducible promoter is a GRE5 promoter.
9. The cell of Claim 7 wherein said inducible promoter is an MMTV promoter.
10. The cell of Claim 5 or 6 wherein at least one of said inducible promoters is an antibiotic-responsive promoter.



11. The cell of Claim 10 wherein said antibiotic-responsive promoter is a tetracycline-responsive promoter.
12. The cell of Claims 5 or 6 wherein said first inducible promoter is a GRE5 promoter, said second inducible promoter is an MMTV promoter, and said third inducible promoter is a tetracycline-responsive promoter.
13. The cell of Claims 5 or 6, wherein said cell is a human epithelial-like cell.
14. The cell of Claim 13 wherein said cell is an A549 cell.
15. The cell of claim 13 wherein said cell is a KB cell.
16. The cell of claim 13 wherein said cell is a Hep-2 cell.
17. A method of expressing a protein or polypeptide in a host, comprising administering to said host the adenoviral vector of any one of Claims 1 to 4.
18. A method of expressing a protein or polypeptide in a eukaryotic cell, comprising: transducing a eukaryotic cell with the adenoviral vector of any one of Claims 1 to 4.
19. A eukaryotic cell transfected with the adenoviral vector of any one of Claims 1 to 4.
20. The adenoviral vector of any of Claims 1 to 4 for use as a medicament.
21. Use of the adenoviral vector of any of Claims 1 to 4 for the preparation of a medicament for the treatment of a disease in a mammal including a human.
22. A method for the treatment of disease in a mammal, including a human, wherein said treatment comprises administering a therapeutically effective amount of the adenoviral vector of any one of Claims 1 to 4.
23. The adenoviral vector of any one of Claims 1 to 4 when used in the treatment of disease in a mammal, including a human.
24. A method of effecting a gene therapy treatment, comprising: administering to a host the adenoviral vector of any one of Claims 1 to 4 in an amount effective to produce a therapeutic effect in a host.
25. The adenoviral vector of any one of Claims 1 to 4 when used in effecting a gene therapy treatment.
26. Use of the adenoviral vector of any one of Claims 1 to 4 in the preparation of a medicament for effecting a gene therapy treatment.



27. An adenoviral vector, substantially as hereinbefore described with reference to any one of the examples.

28. A stable cell for complementing adenoviral early protein functions for use in the production of adenoviral vector, substantially as hereinbefore described with reference to any one of the examples.

Dated 8 July, 1999
Genetic Therapy, Inc.

Patent Attorneys for the Applicant/Nominated Person
SPRUSON & FERGUSON

3
10
17
24
31
38
45
52
59
66
73
80
87
94
101
108
115
122
129
136
143
150
157
164
171
178
185
192
199
206
213
220
227
234
241
248
255
262
269
276
283
290
297
304
311
318
325
332
339
346
353
360
367
374
381
388
395
402
409
416
423
430
437
444
451
458
465
472
479
486
493
500
507
514
521
528
535
542
549
556
563
570
577
584
591
598
605
612
619
626
633
640
647
654
661
668
675
682
689
696
703
710
717
724
731
738
745
752
759
766
773
780
787
794
801
808
815
822
829
836
843
850
857
864
871
878
885
892
899
906
913
920
927
934
941
948
955
962
969
976
983
990
997
1004
1011
1018
1025
1032
1039
1046
1053
1060
1067
1074
1081
1088
1095
1102
1109
1116
1123
1130
1137
1144
1151
1158
1165
1172
1179
1186
1193
1200
1207
1214
1221
1228
1235
1242
1249
1256
1263
1270
1277
1284
1291
1298
1305
1312
1319
1326
1333
1340
1347
1354
1361
1368
1375
1382
1389
1396
1403
1410
1417
1424
1431
1438
1445
1452
1459
1466
1473
1480
1487
1494
1501
1508
1515
1522
1529
1536
1543
1550
1557
1564
1571
1578
1585
1592
1599
1606
1613
1620
1627
1634
1641
1648
1655
1662
1669
1676
1683
1690
1697
1704
1711
1718
1725
1732
1739
1746
1753
1760
1767
1774
1781
1788
1795
1802
1809
1816
1823
1830
1837
1844
1851
1858
1865
1872
1879
1886
1893
1900
1907
1914
1921
1928
1935
1942
1949
1956
1963
1970
1977
1984
1991
1998
2005
2012
2019
2026
2033
2040
2047
2054
2061
2068
2075
2082
2089
2096
2103
2110
2117
2124
2131
2138
2145
2152
2159
2166
2173
2180
2187
2194
2201
2208
2215
2222
2229
2236
2243
2250
2257
2264
2271
2278
2285
2292
2299
2306
2313
2320
2327
2334
2341
2348
2355
2362
2369
2376
2383
2390
2397
2404
2411
2418
2425
2432
2439
2446
2453
2460
2467
2474
2481
2488
2495
2502
2509
2516
2523
2530
2537
2544
2551
2558
2565
2572
2579
2586
2593
2600
2607
2614
2621
2628
2635
2642
2649
2656
2663
2670
2677
2684
2691
2698
2705
2712
2719
2726
2733
2740
2747
2754
2761
2768
2775
2782
2789
2796
2803
2810
2817
2824
2831
2838
2845
2852
2859
2866
2873
2880
2887
2894
2901
2908
2915
2922
2929
2936
2943
2950
2957
2964
2971
2978
2985
2992
2999
3006
3013
3020
3027
3034
3041
3048
3055
3062
3069
3076
3083
3090
3097
3104
3111
3118
3125
3132
3139
3146
3153
3160
3167
3174
3181
3188
3195
3202
3209
3216
3223
3230
3237
3244
3251
3258
3265
3272
3279
3286
3293
3300
3307
3314
3321
3328
3335
3342
3349
3356
3363
3370
3377
3384
3391
3398
3405
3412
3419
3426
3433
3440
3447
3454
3461
3468
3475
3482
3489
3496
3503
3510
3517
3524
3531
3538
3545
3552
3559
3566
3573
3580
3587
3594
3601
3608
3615
3622
3629
3636
3643
3650
3657
3664
3671
3678
3685
3692
3699
3706
3713
3720
3727
3734
3741
3748
3755
3762
3769
3776
3783
3790
3797
3804
3811
3818
3825
3832
3839
3846
3853
3860
3867
3874
3881
3888
3895
3902
3909
3916
3923
3930
3937
3944
3951
3958
3965
3972
3979
3986
3993
4000
4007
4014
4021
4028
4035
4042
4049
4056
4063
4070
4077
4084
4091
4098
4105
4112
4119
4126
4133
4140
4147
4154
4161
4168
4175
4182
4189
4196
4203
4210
4217
4224
4231
4238
4245
4252
4259
4266
4273
4280
4287
4294
4301
4308
4315
4322
4329
4336
4343
4350
4357
4364
4371
4378
4385
4392
4399
4406
4413
4420
4427
4434
4441
4448
4455
4462
4469
4476
4483
4490
4497
4504
4511
4518
4525
4532
4539
4546
4553
4560
4567
4574
4581
4588
4595
4602
4609
4616
4623
4630
4637
4644
4651
4658
4665
4672
4679
4686
4693
4700
4707
4714
4721
4728
4735
4742
4749
4756
4763
4770
4777
4784
4791
4798
4805
4812
4819
4826
4833
4840
4847
4854
4861
4868
4875
4882
4889
4896
4903
4910
4917
4924
4931
4938
4945
4952
4959
4966
4973
4980
4987
4994
5001
5008
5015
5022
5029
5036
5043
5050
5057
5064
5071
5078
5085
5092
5099
5106
5113
5120
5127
5134
5141
5148
5155
5162
5169
5176
5183
5190
5197
5204
5211
5218
5225
5232
5239
5246
5253
5260
5267
5274
5281
5288
5295
5302
5309
5316
5323
5330
5337
5344
5351
5358
5365
5372
5379
5386
5393
5400
5407
5414
5421
5428
5435
5442
5449
5456
5463
5470
5477
5484
5491
5498
5505
5512
5519
5526
5533
5540
5547
5554
5561
5568
5575
5582
5589
5596
5603
5610
5617
5624
5631
5638
5645
5652
5659
5666
5673
5680
5687
5694
5701
5708
5715
5722
5729
5736
5743
5750
5757
5764
5771
5778
5785
5792
5799
5806
5813
5820
5827
5834
5841
5848
5855
5862
5869
5876
5883
5890
5897
5904
5911
5918
5925
5932
5939
5946
5953
5960
5967
5974
5981
5988
5995
6002
6009
6016
6023
6030
6037
6044
6051
6058
6065
6072
6079
6086
6093
6100
6107
6114
6121
6128
6135
6142
6149
6156
6163
6170
6177
6184
6191
6198
6205
6212
6219
6226
6233
6240
6247
6254
6261
6268
6275
6282
6289
6296
6303
6310
6317
6324
6331
6338
6345
6352
6359
6366
6373
6380
6387
6394
6401
6408
6415
6422
6429
6436
6443
6450
6457
6464
6471
6478
6485
6492
6499
6506
6513
6520
6527
6534
6541
6548
6555
6562
6569
6576
6583
6590
6597
6604
6611
6618
6625
6632
6639
6646
6653
6660
6667
6674
6681
6688
6695
6702
6709
6716
6723
6730
6737
6744
6751
6758
6765
6772
6779
6786
6793
6800
6807
6814
6821
6828
6835
6842
6849
6856
6863
6870
6877
6884
6891
6898
6905
6912
6919
6926
6933
6940
6947
6954
6961
6968
6975
6982
6989
6996
7003
7010
7017
7024
7031
7038
7045
7052
7059
7066
7073
7080
7087
7094
7101
7108
7115
7122
7129
7136
7143
7150
7157
7164
7171
7178
7185
7192
7199
7206
7213
7220
7227
7234
7241
7248
7255
7262
7269
7276
7283
7290
7297
7304
7311
7318
7325
7332
7339
7346
7353
7360
7367
7374
7381
7388
7395
7402
7409
7416
7423
7430
7437
7444
7451
7458
7465
7472
7479
7486
7493
7500
7507
7514
7521
7528
7535
7542
7549
7556
7563
7570
7577
7584
7591
7598
7605
7612
7619
7626
7633
7640
7647
7654
7661
7668
7675
7682
7689
7696
7703
7710
7717
7724
7731
7738
7745
7752
7759
7766
7773
7780
7787
7794
7801
7808
7815
7822
7829
7836
7843
7850
7857
7864
7871
7878
7885
7892
7899
7906
7913
7920
7927
7934
7941
7948
7955
7962
7969
7976
7983
7990
7997
8004
8011
8018
8025
8032
8039
8046
8053
8060
8067
8074
8081
8088
8095
8102
8109
8116
8123
8130
8137
8144
8151
8158
8165
8172
8179
8186
8193
8200
8207
8214
8221
8228
8235
8242
8249
8256
8263
8270
8277
8284
8291
8298
8305
8312
8319
8326
8333
8340
8347
8354
8361
8368
8375
8382
8389
8396
8403
8410
8417
8424
8431
8438
8445
8452
8459
8466
8473
8480
8487
8494
8501
8508
8515
8522
8529
8536
8543
8550
8557
8564
8571
8578
8585
8592
8599
8606
8613
8620
8627
8634
8641
8648
8655
8662
8669
8676
8683
8690
8697
8704
8711
8718
8725
8732
8739
8746
8753
8760
8767
8774
8781
8788
8795
8802
8809
8816
8823
8830
8837
8844
8851
8858
8865
8872
8879
8886
8893
8900
8907
8914
8921
8928
8935
8942
8949
8956
8963
8970
8977
8984
8991
8998
9005
9012
9019
9026
9033
9040
9047
9054
9061
9068
9075
9082
9089
9096
9103
9110
9117
9124
9131
9138
9145
9152
9159
9166
9173
9180
9187
9194
9201
9208
9215
9222
9229
9236
9243
9250
9257
9264
9271
9278
9285
9292
9299
9306
9313
9320
9327
9334
9341
9348
9355
9362
9369
9376
9383
9390
9397
9404
9411
9418
9425
9432
9439
9446
9453
9460
9467
9474
9481
9488
9495
9502
9509
9516
9523
9530
9537
9544
9551
9558
9565
9572
9579
9586
9593
9600
9607
9614
9621
9628
9635
9642
9649
9656
9663
9670
9677
9684
9691
9698
9705
9712
9719
9726
9733
9740
9747
9754
9761
9768
9775
9782
9789
9796
9803
9810
9817
9824
9831
9838
9845
9852
9859
9866
9873
9880
9887
9894
9901
9908
9915
9922
9929
9936
9943
9950
9957
9964
9971
9978
9985
9992
9999



FIG. 1

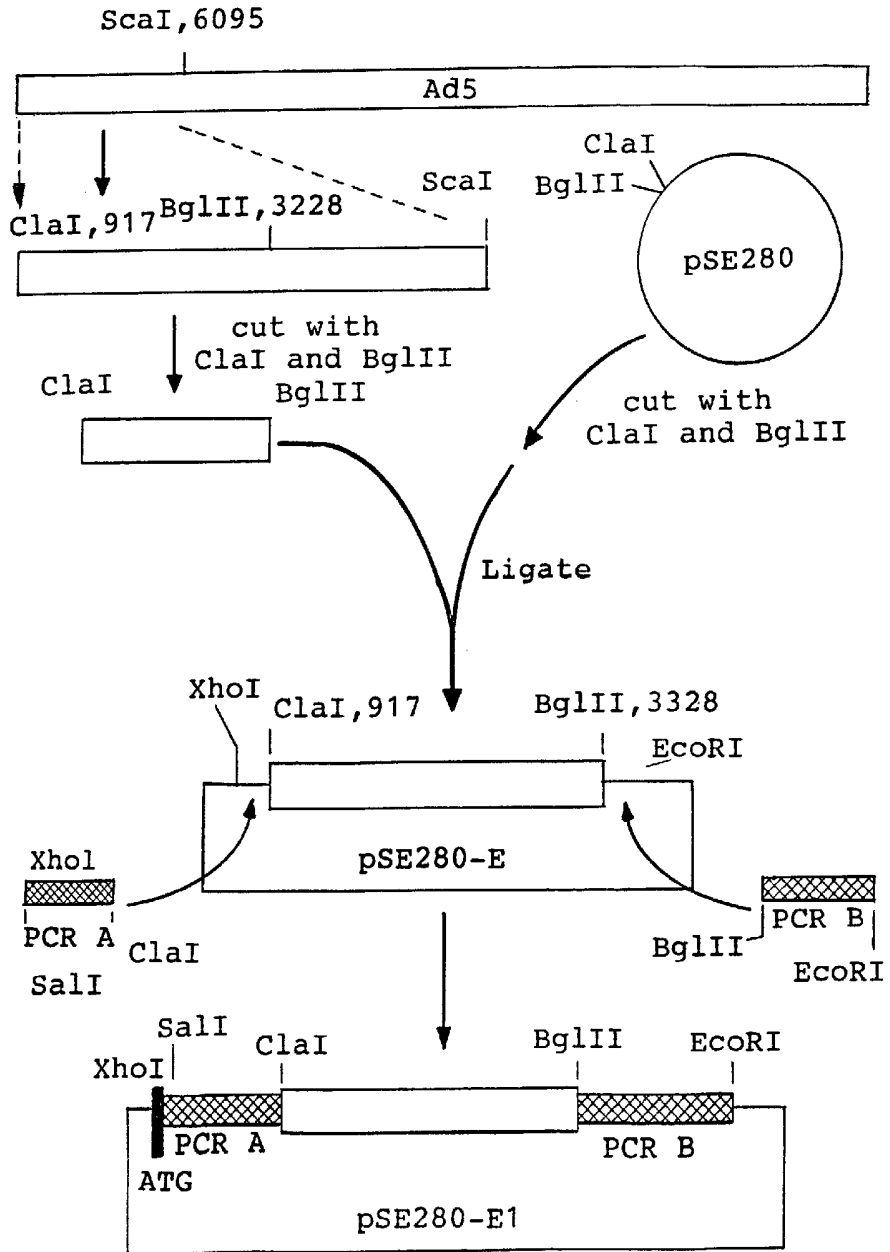
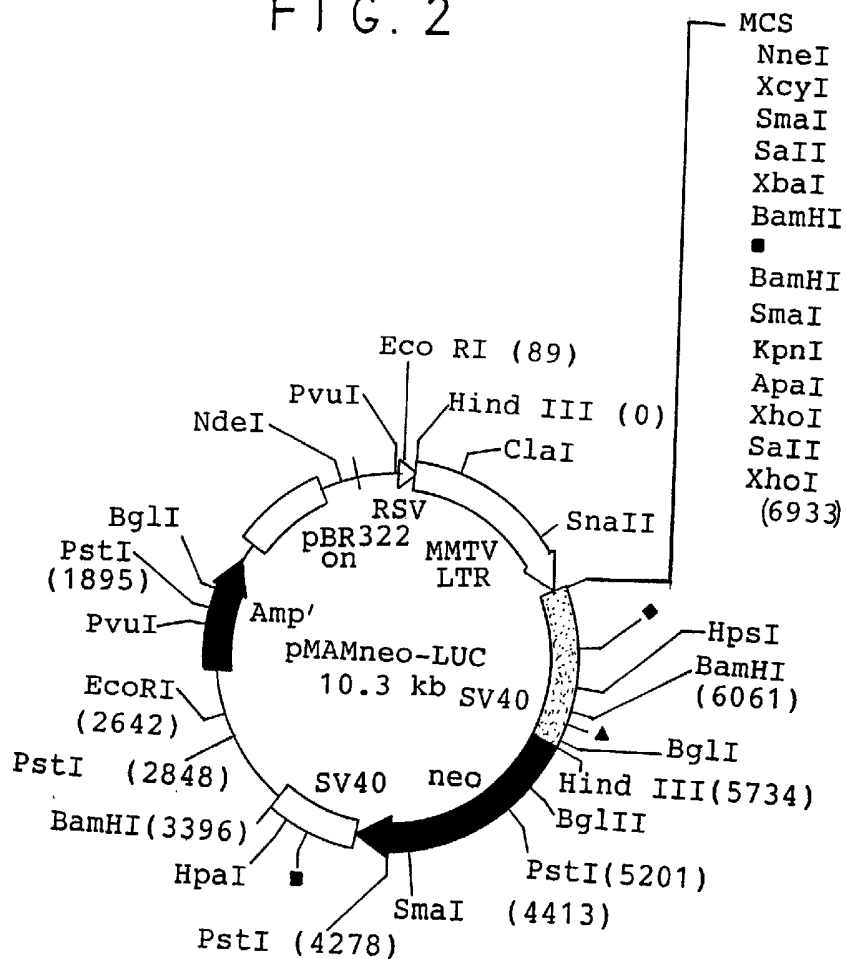

FIG. 2



■ luc pene

▲ SV40 on & early promoter
 ◆ SV40 early splicing region & polyadenylation

SUBSTITUTE SHEET (RULE 26)

03/37

FIG. 3

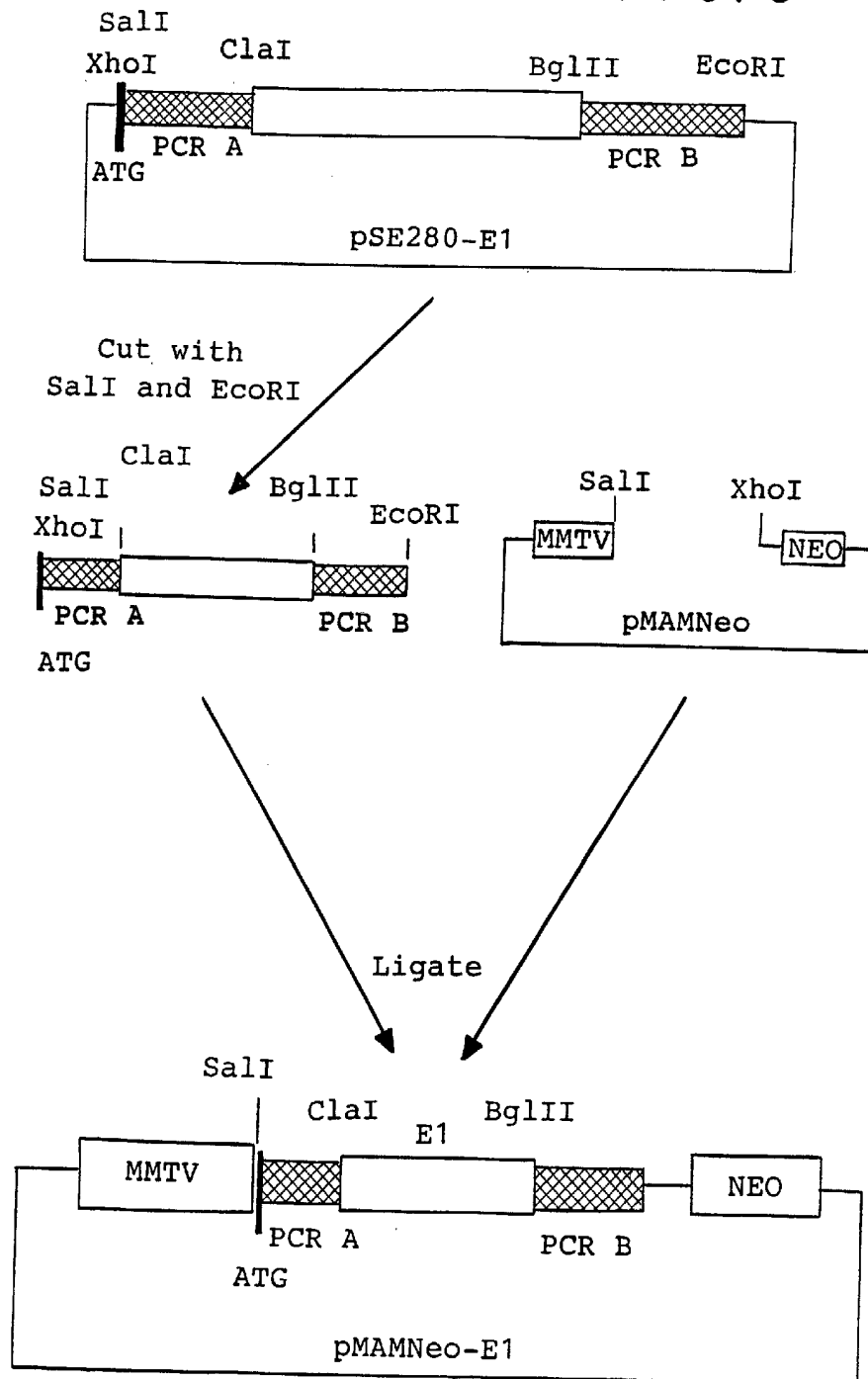

SUBSTITUTE SHEET (RULE 26)

FIG. 4

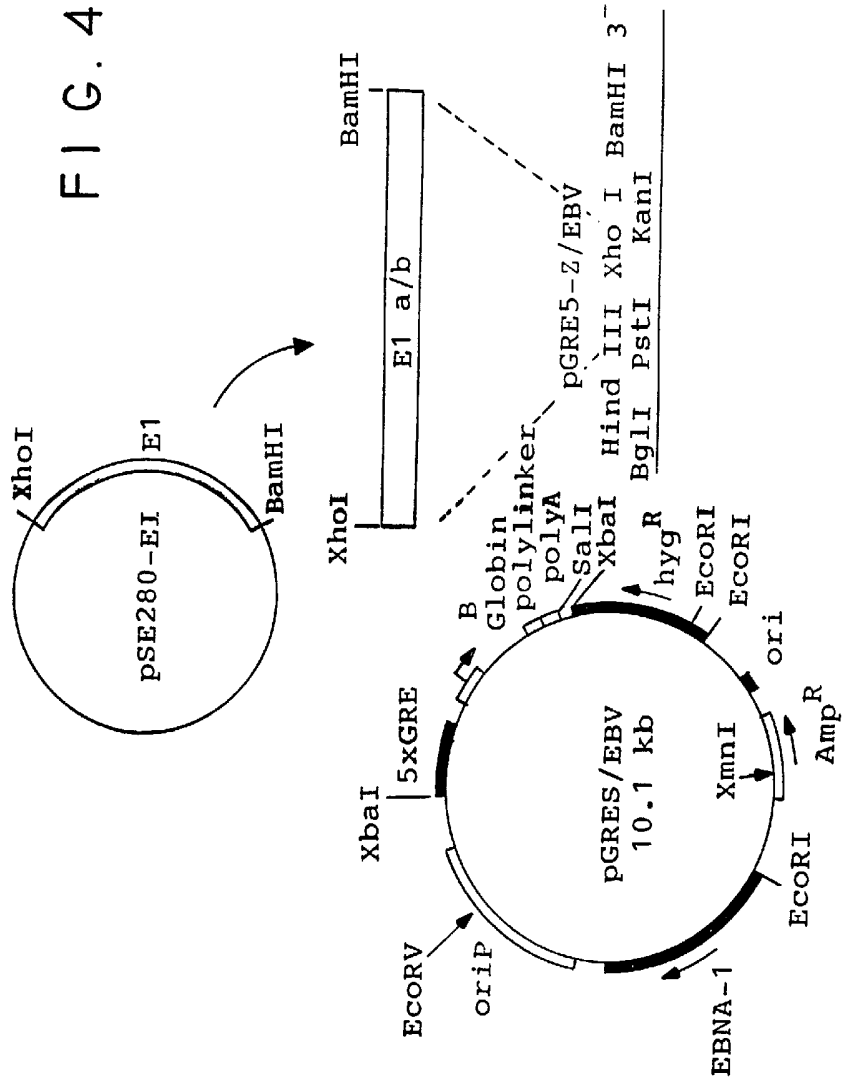

FIG. 5

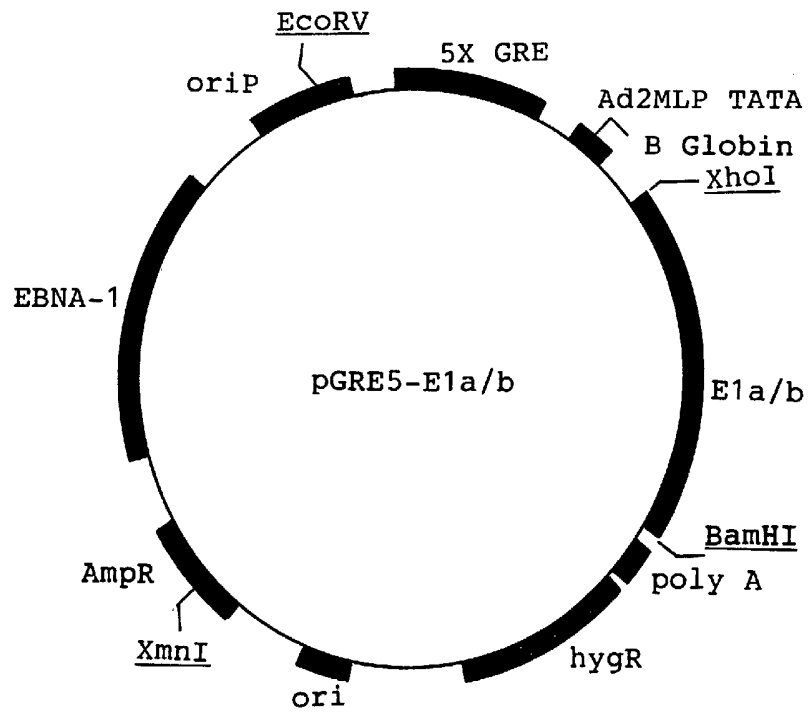

FIG. 6

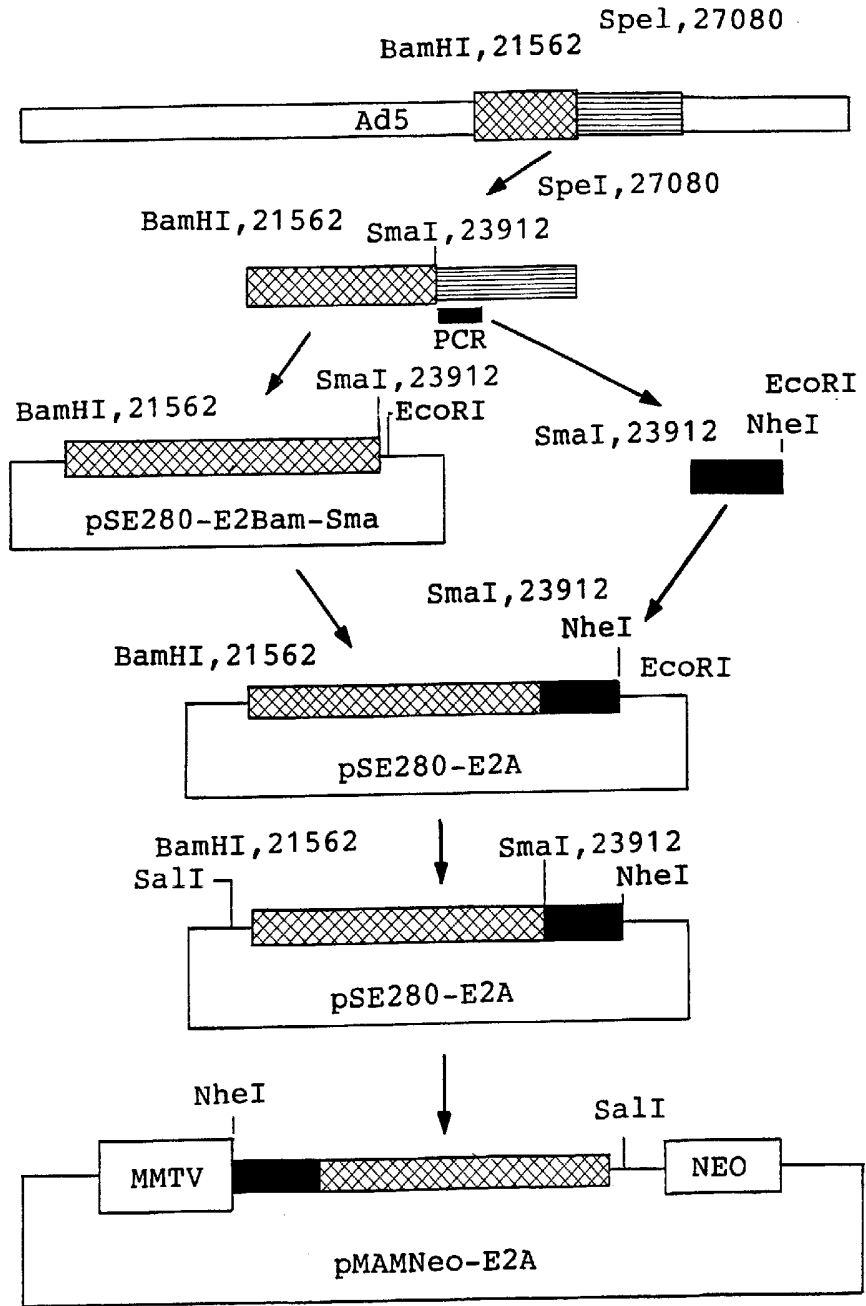

FIG. 7

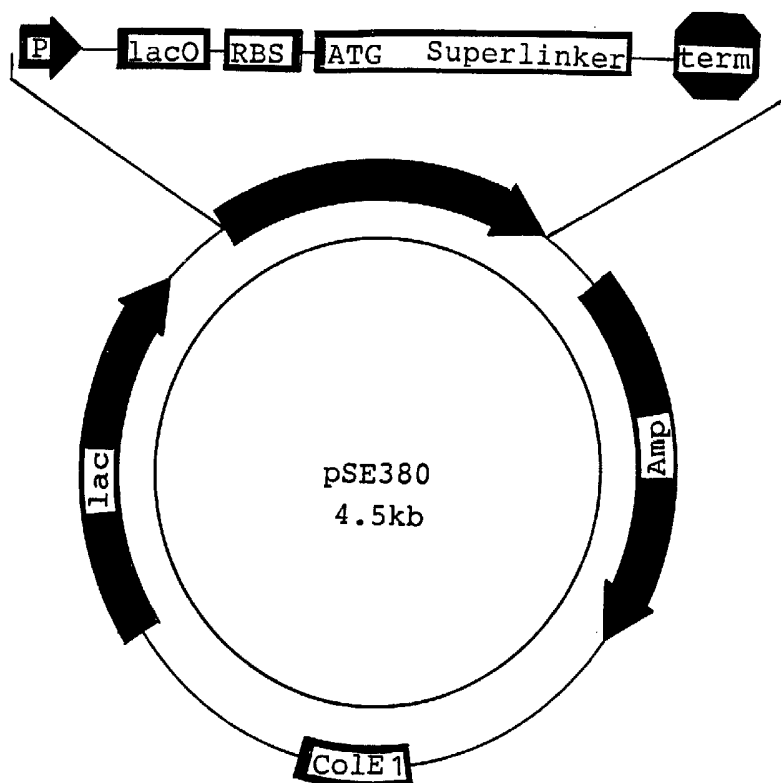

FIG. 8

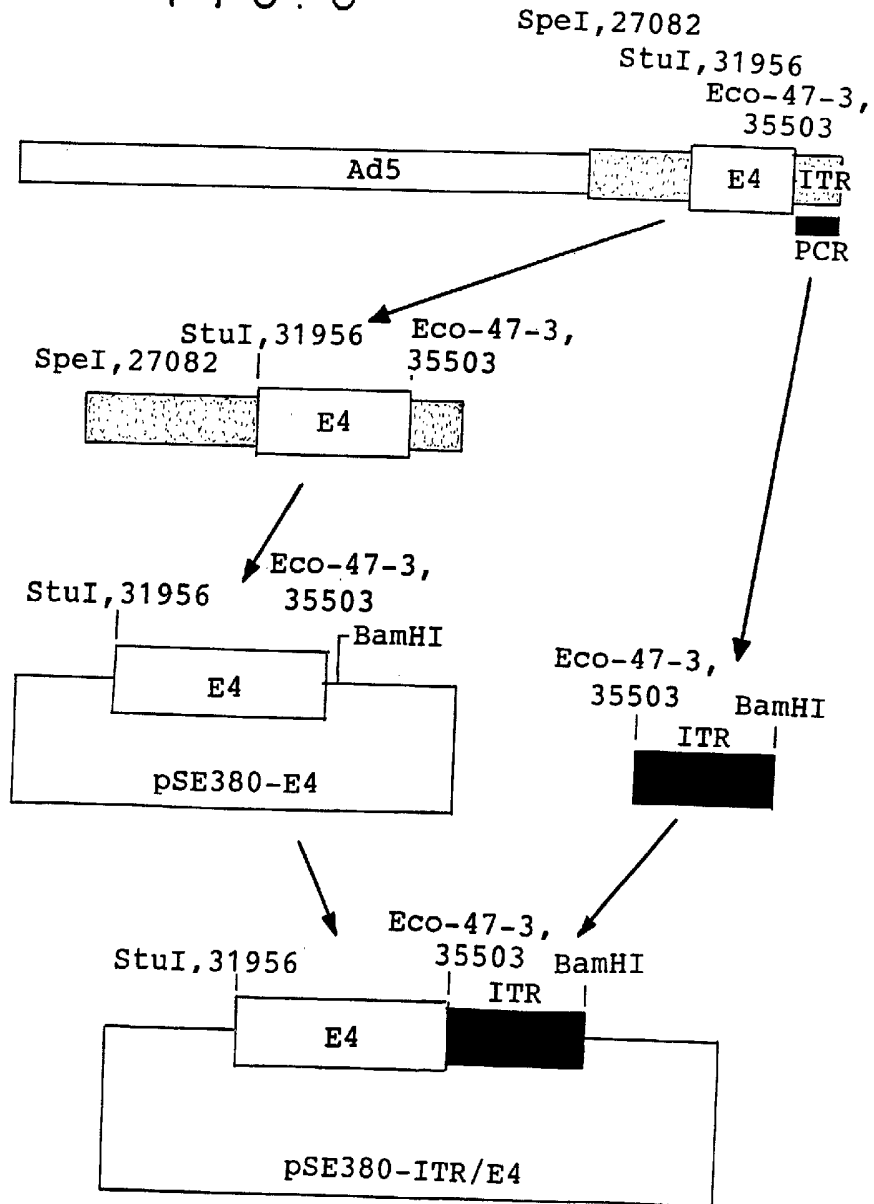

FIG. 9

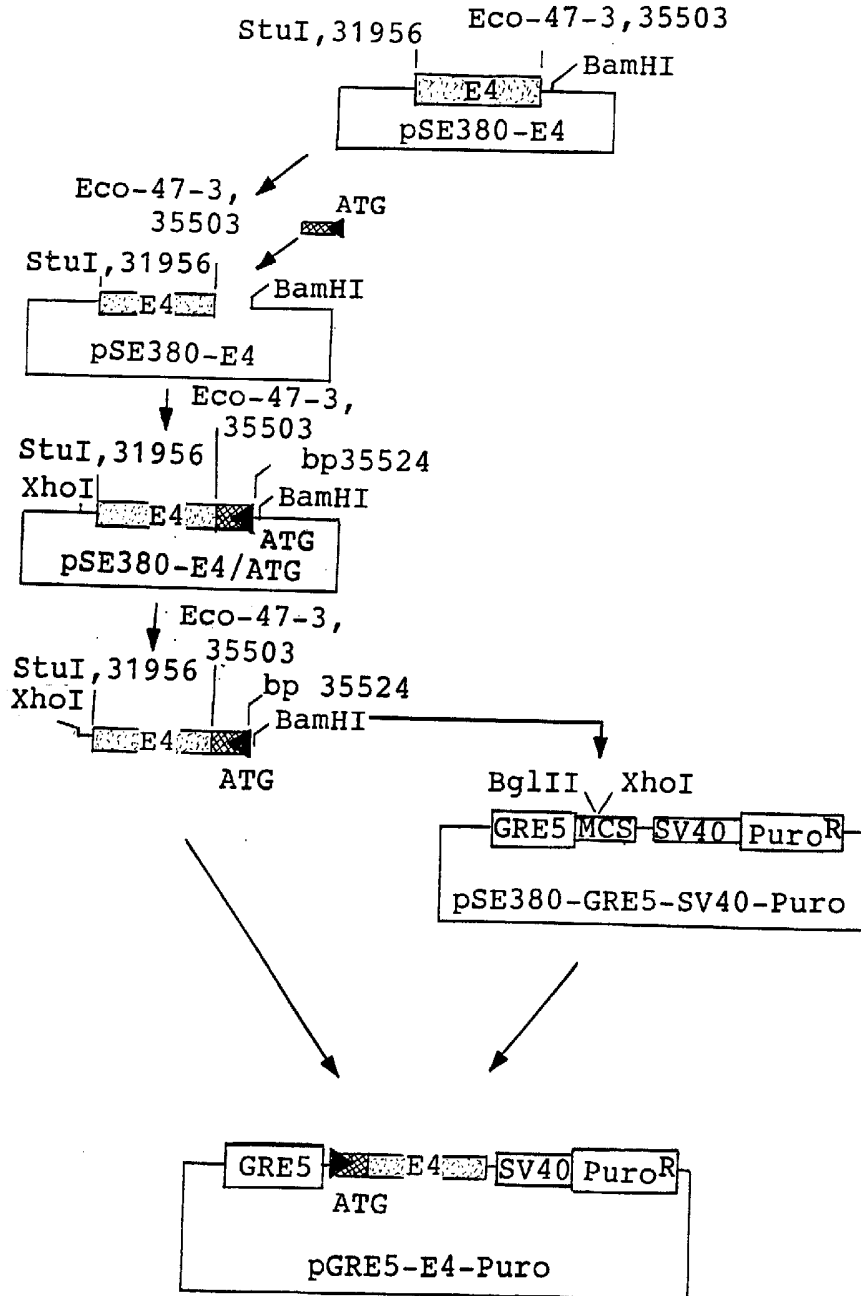
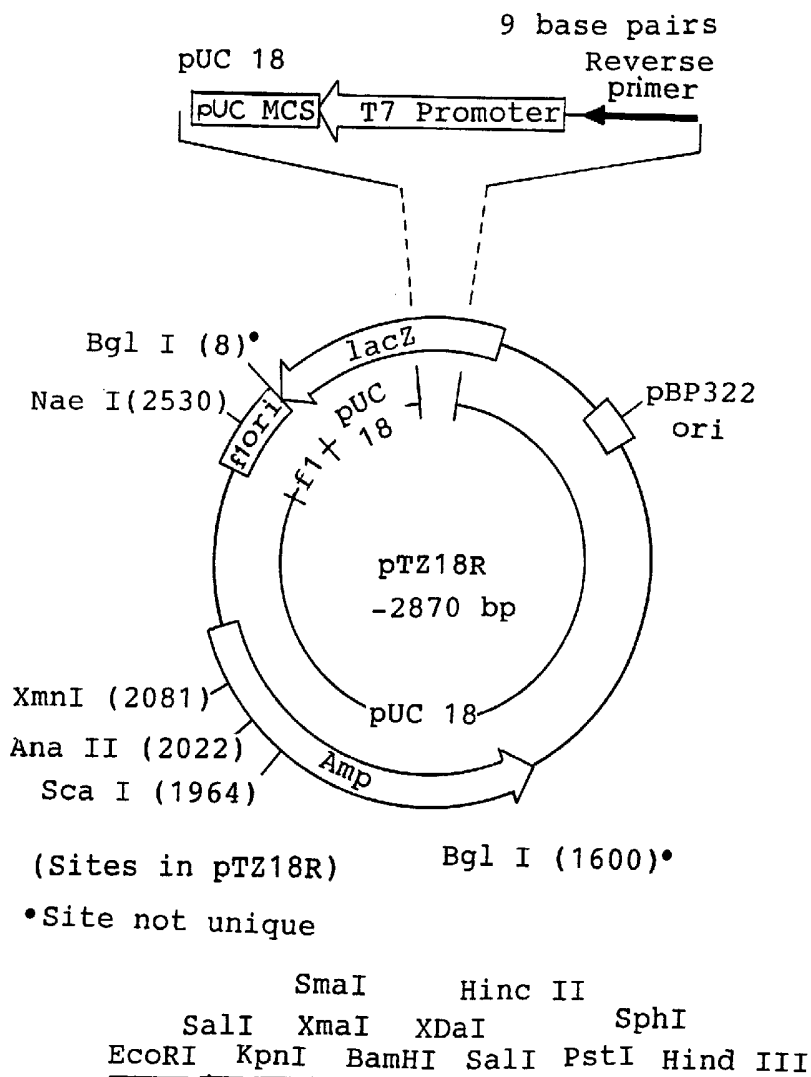
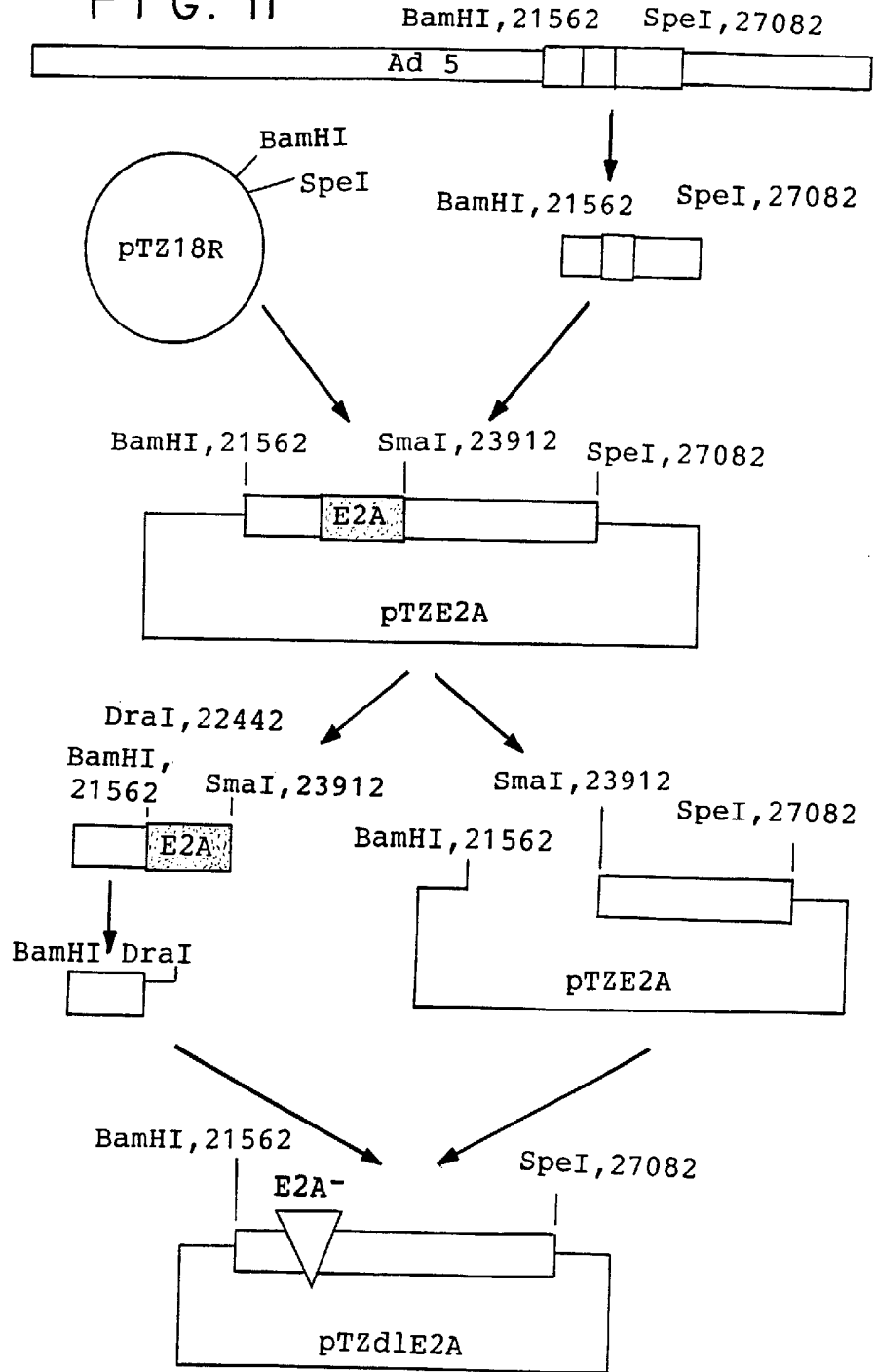

FIG. 10



SUBSTITUTE SHEET (RULE 26)

FIG. II



SUBSTITUTE SHEET (RULE 26)

FIG. 12

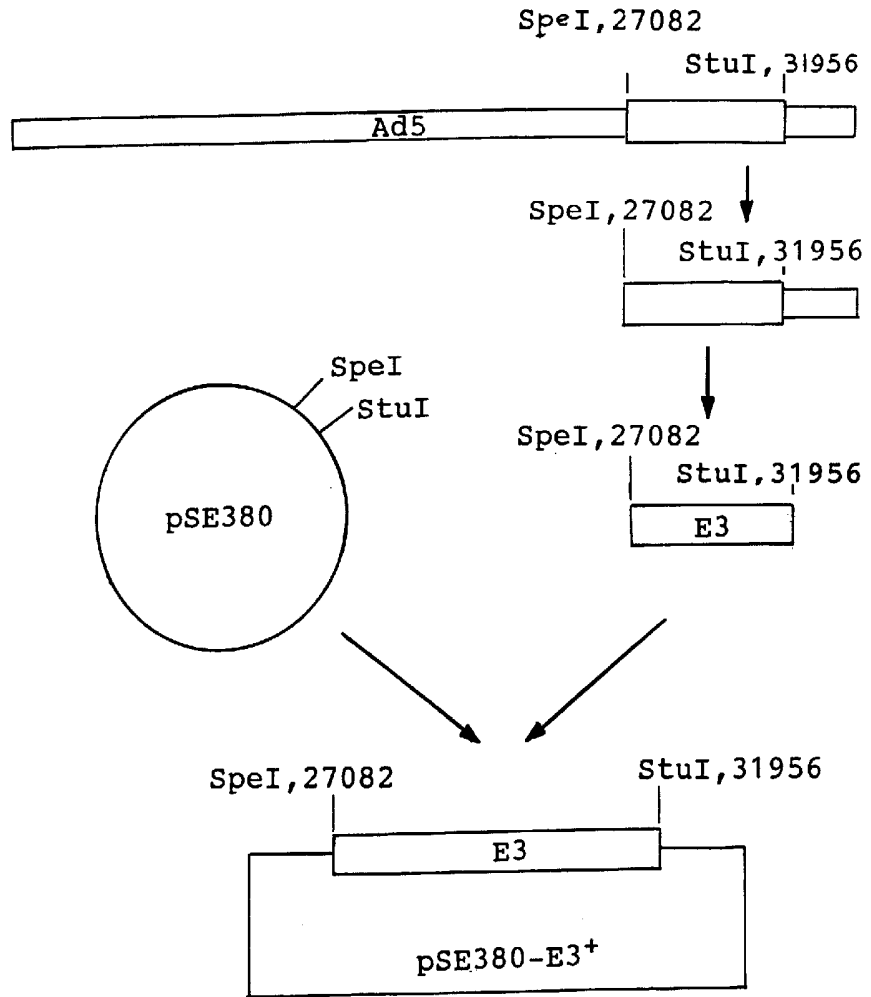

FIG. 13

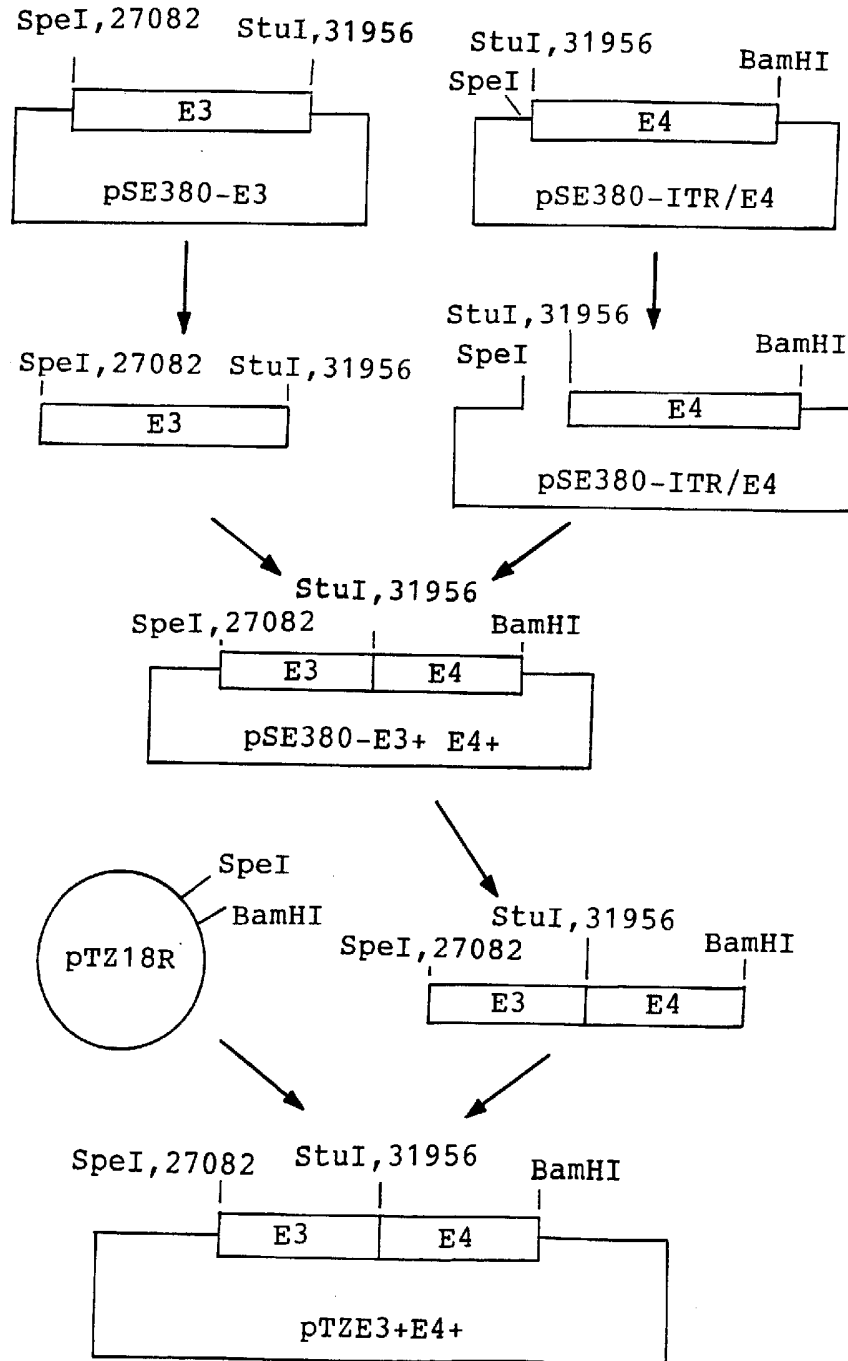
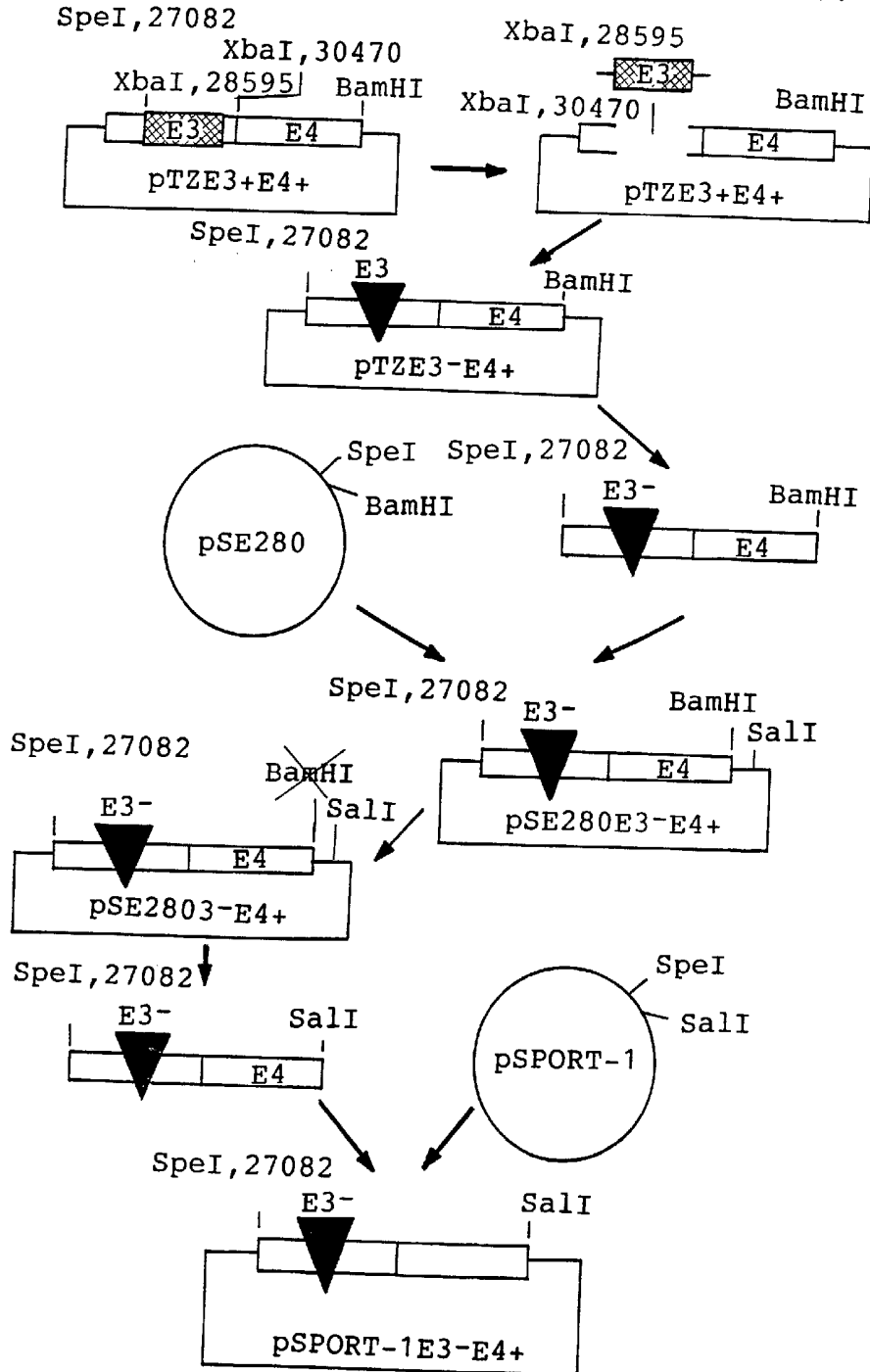
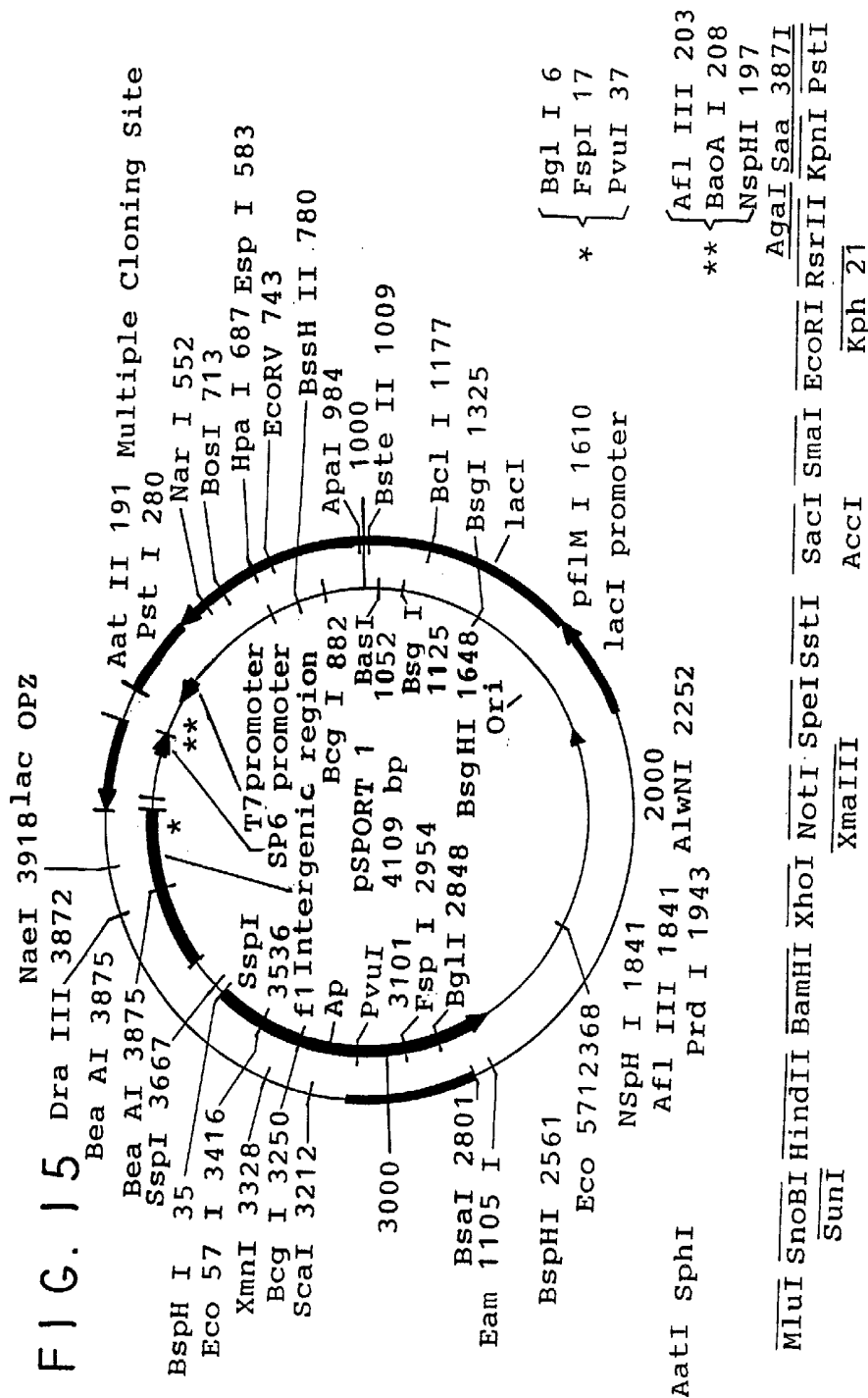

FIG. 14





SUBSTITUTE SHEET (RULE 26)

FIG. 16

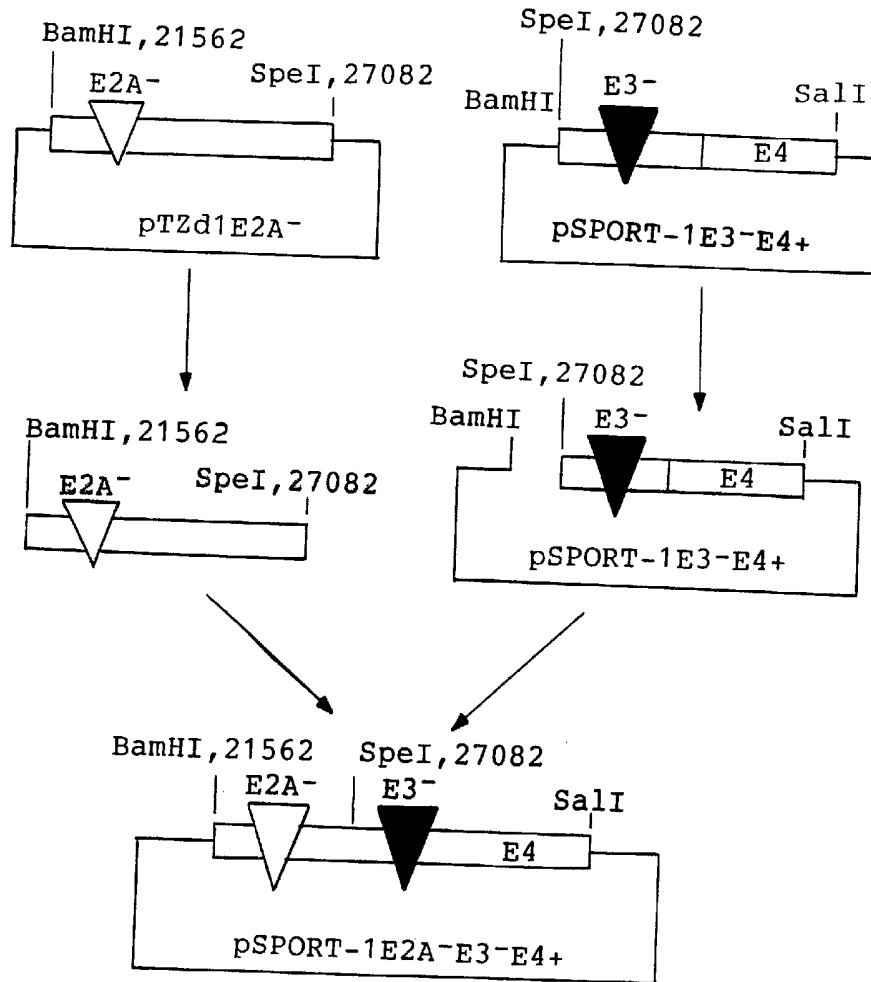
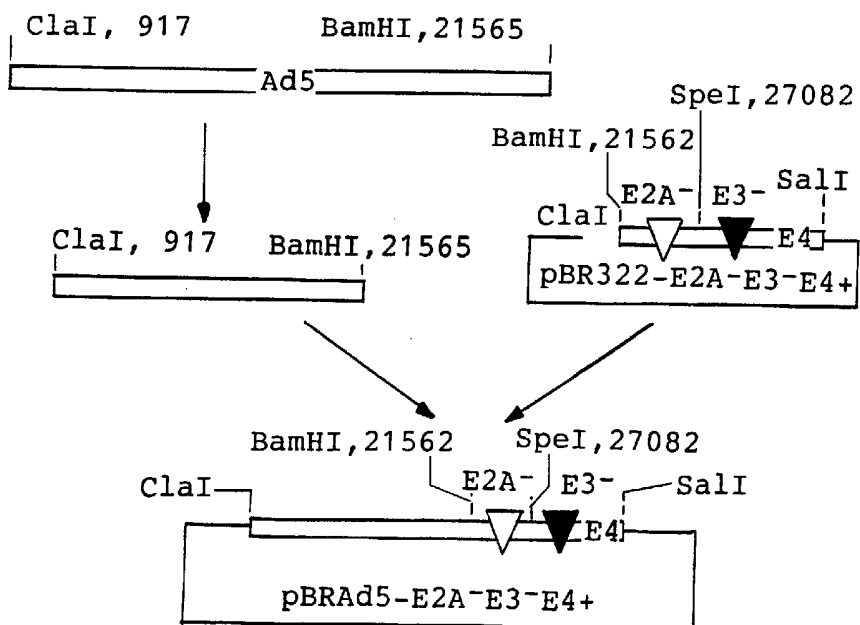
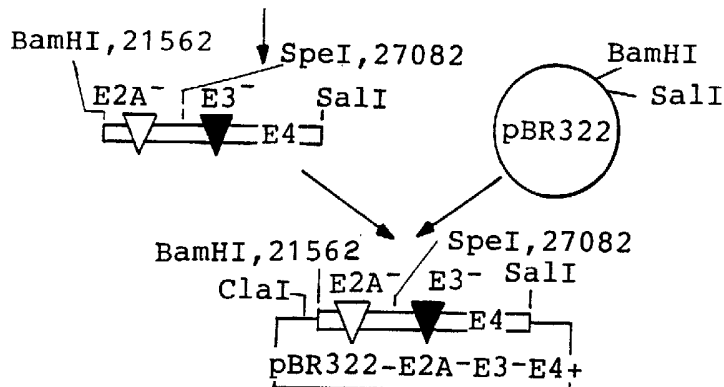
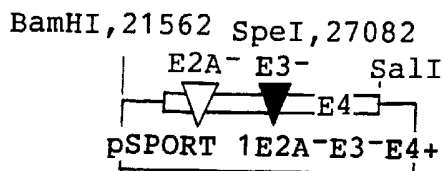
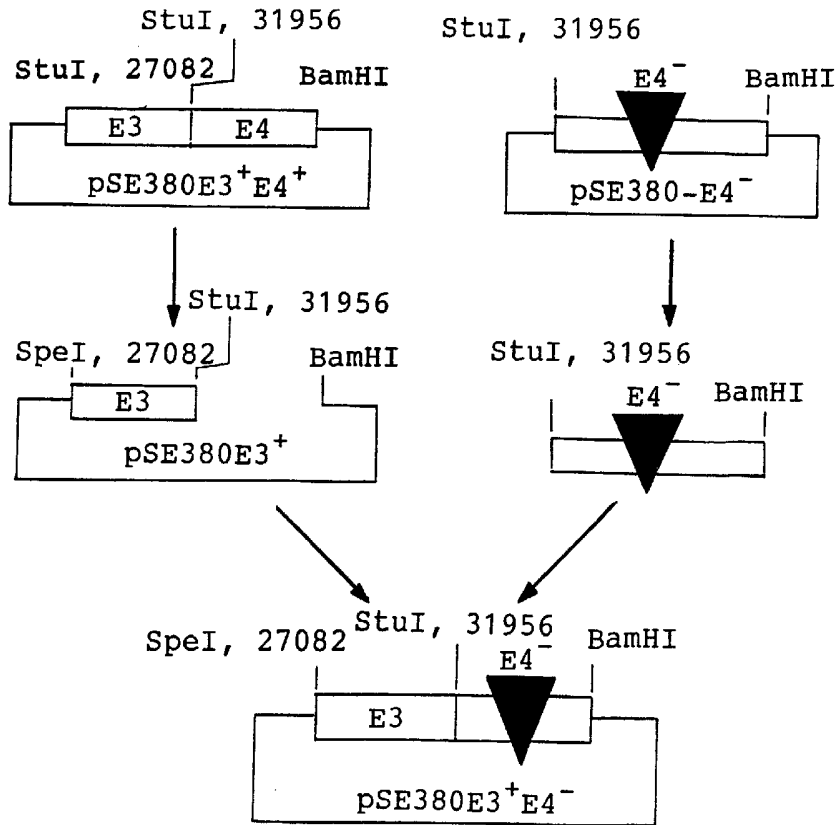
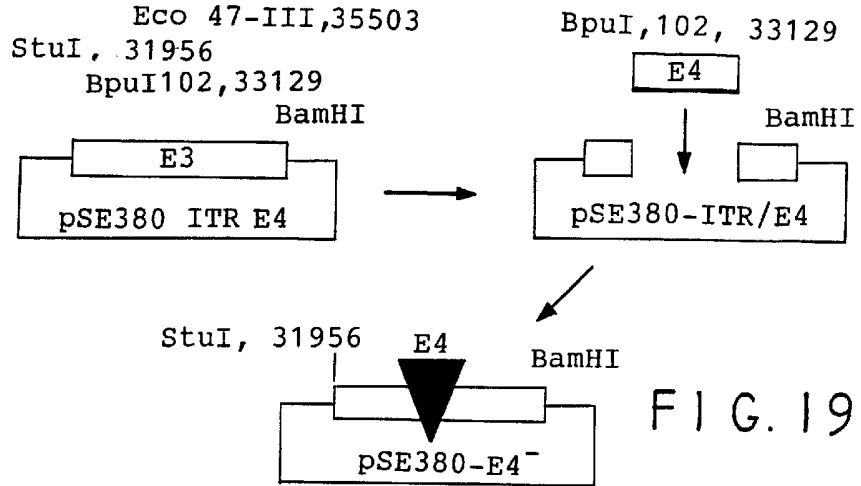

FIG. 18





20/37

FIG. 20

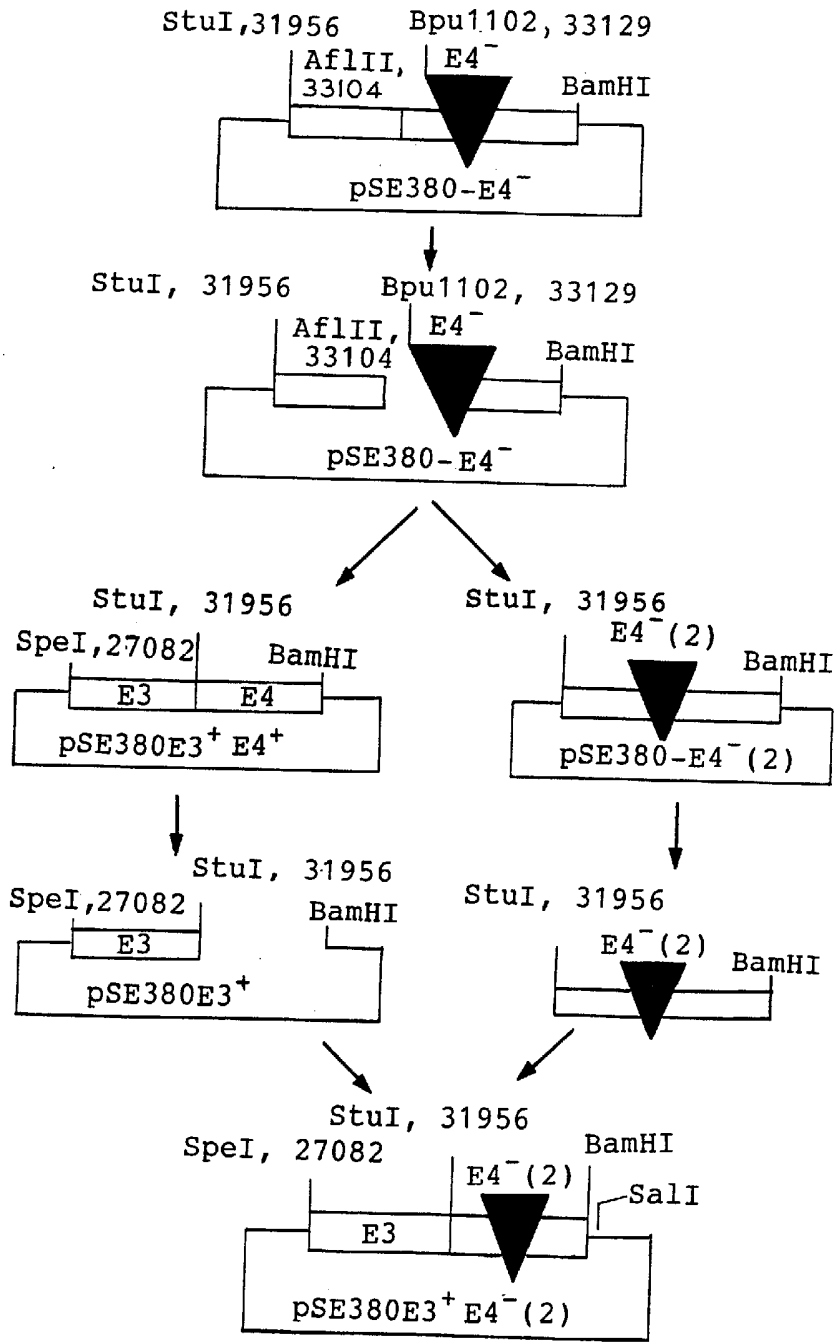

FIG. 21

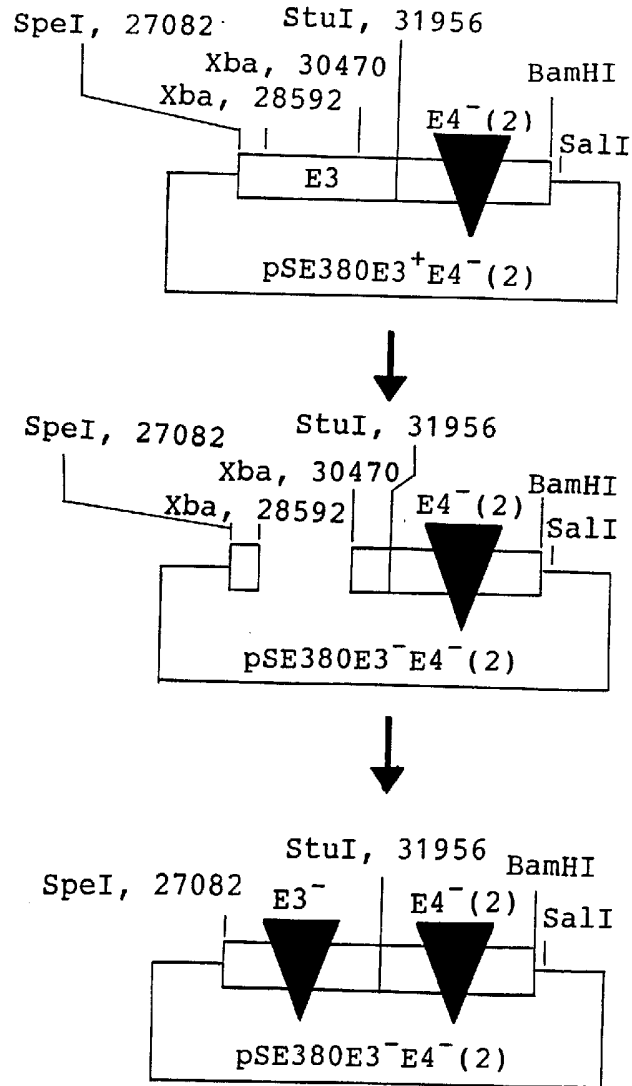

FIG. 22

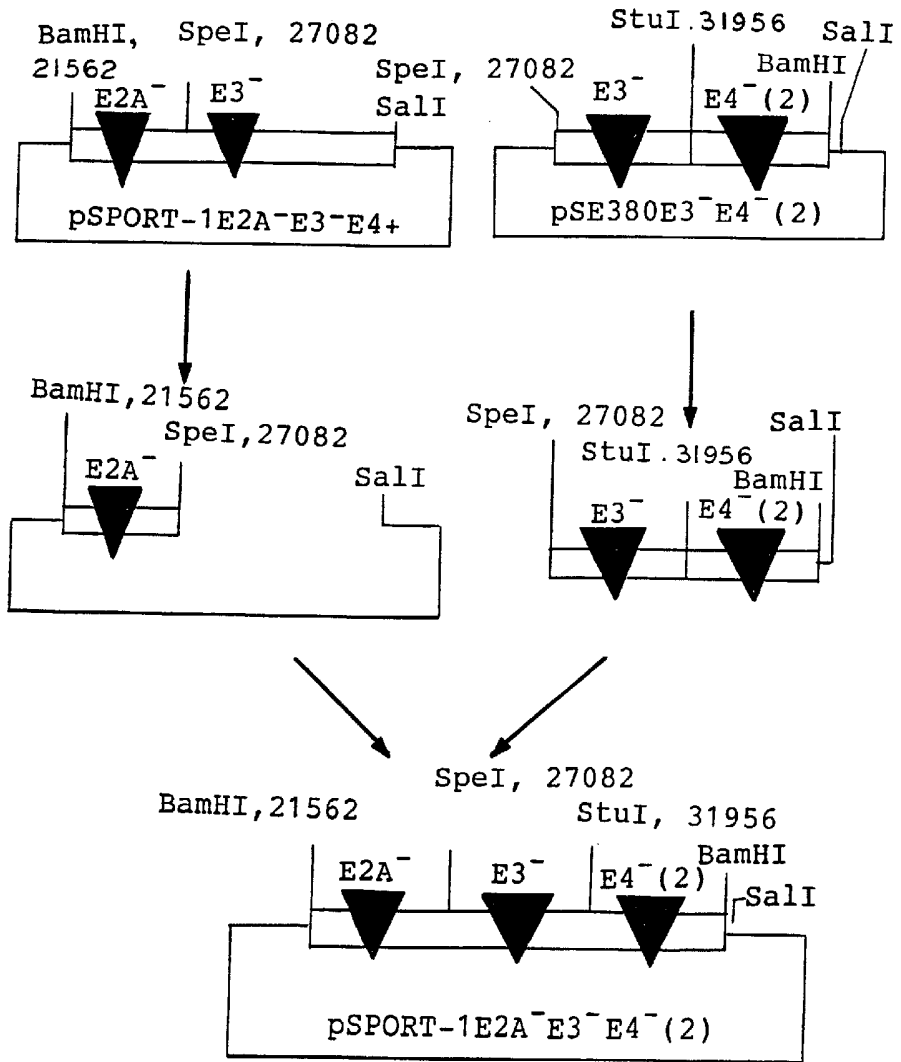

FIG. 23

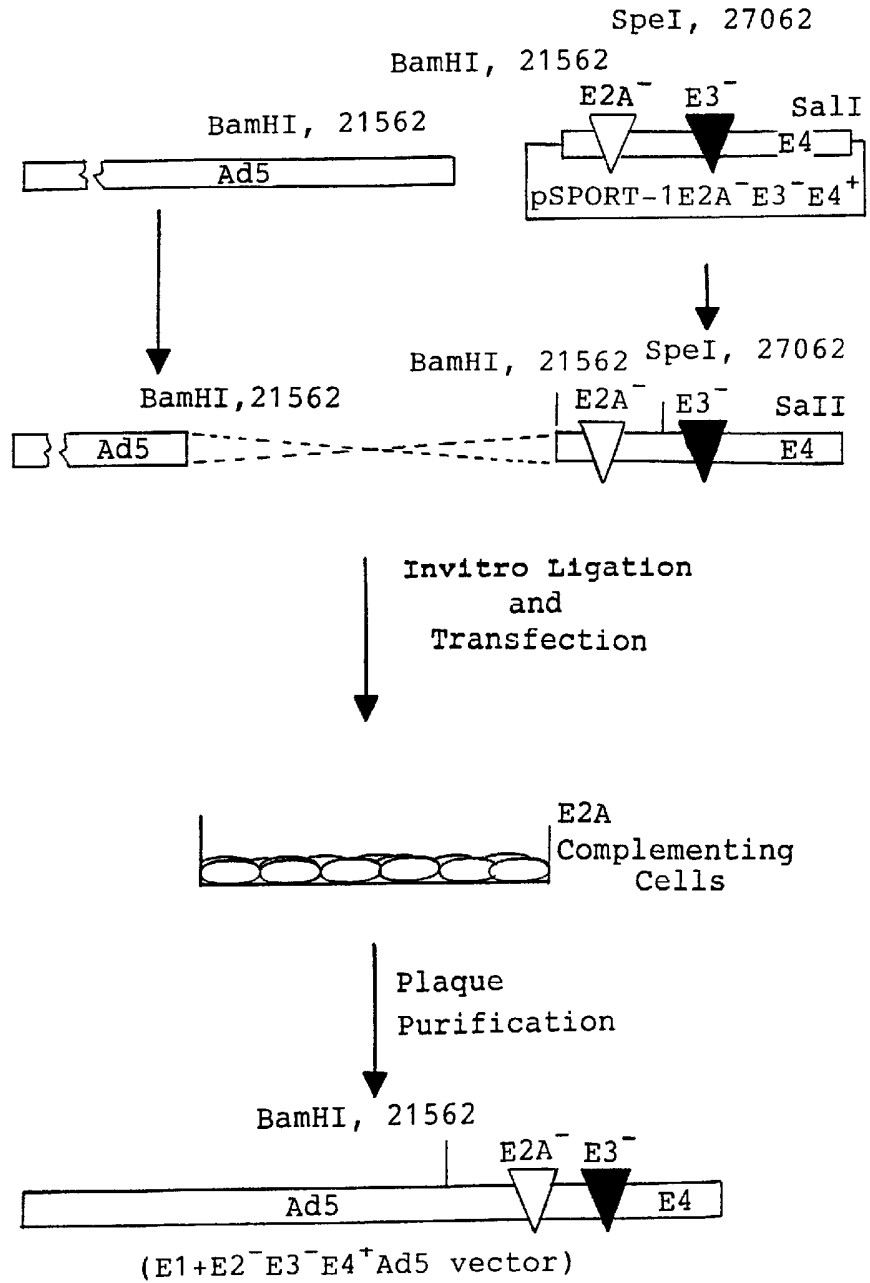
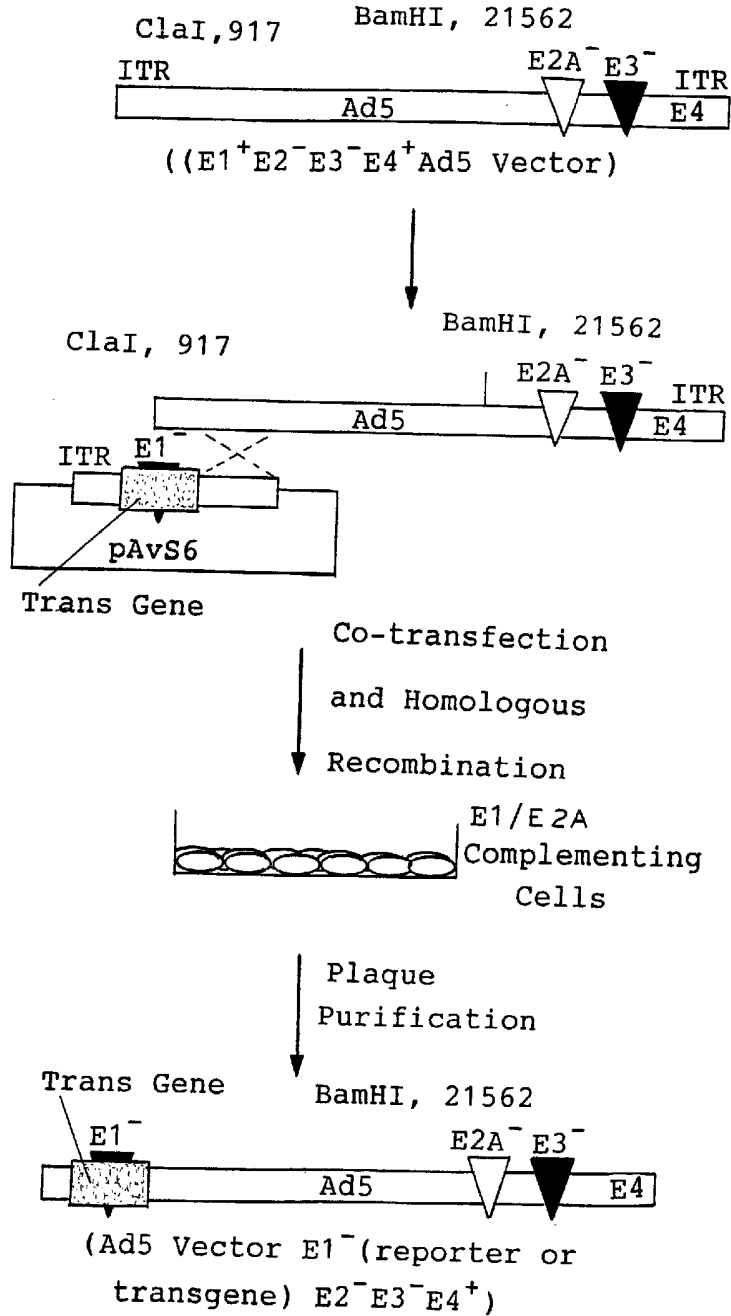

FIG. 25



SUBSTITUTE SHEET (RULE 26)

FIG. 26

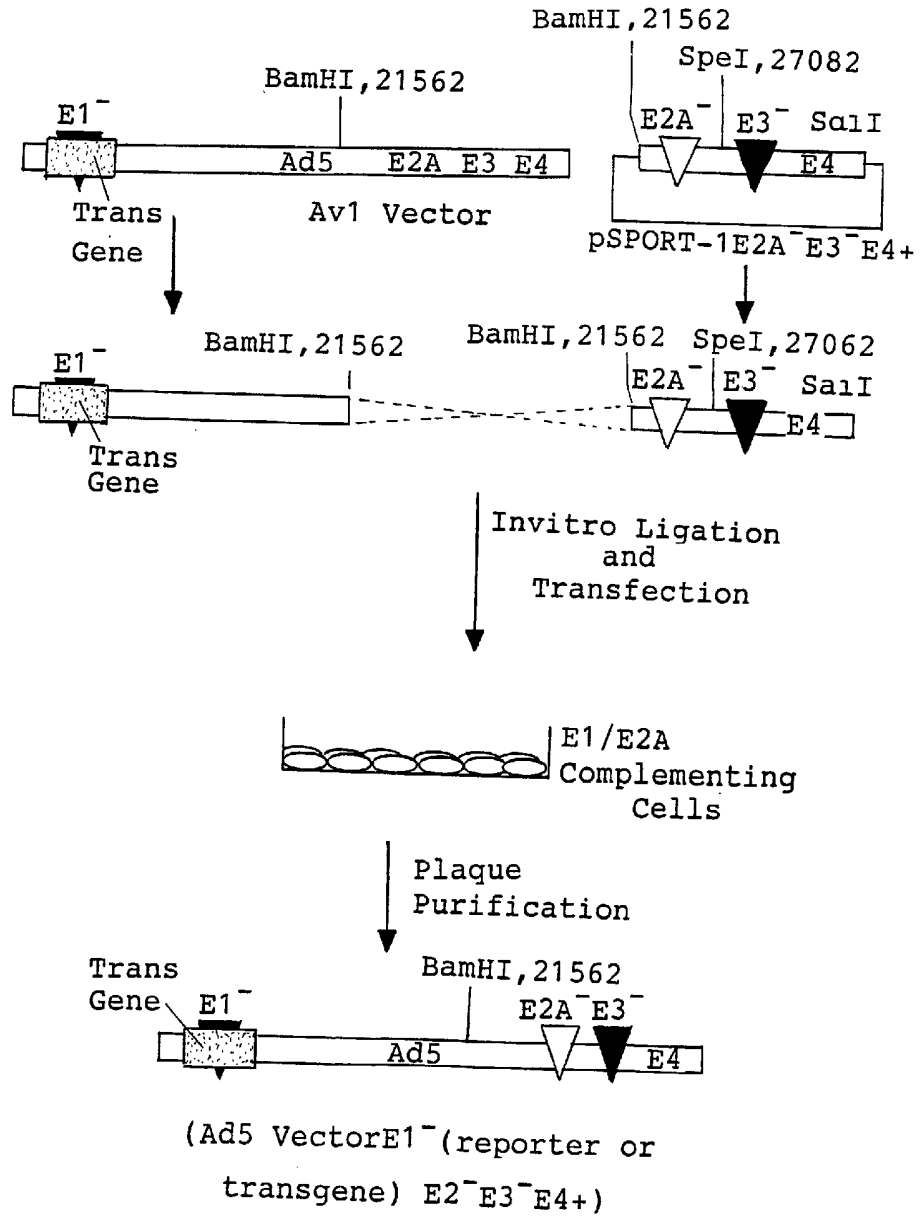
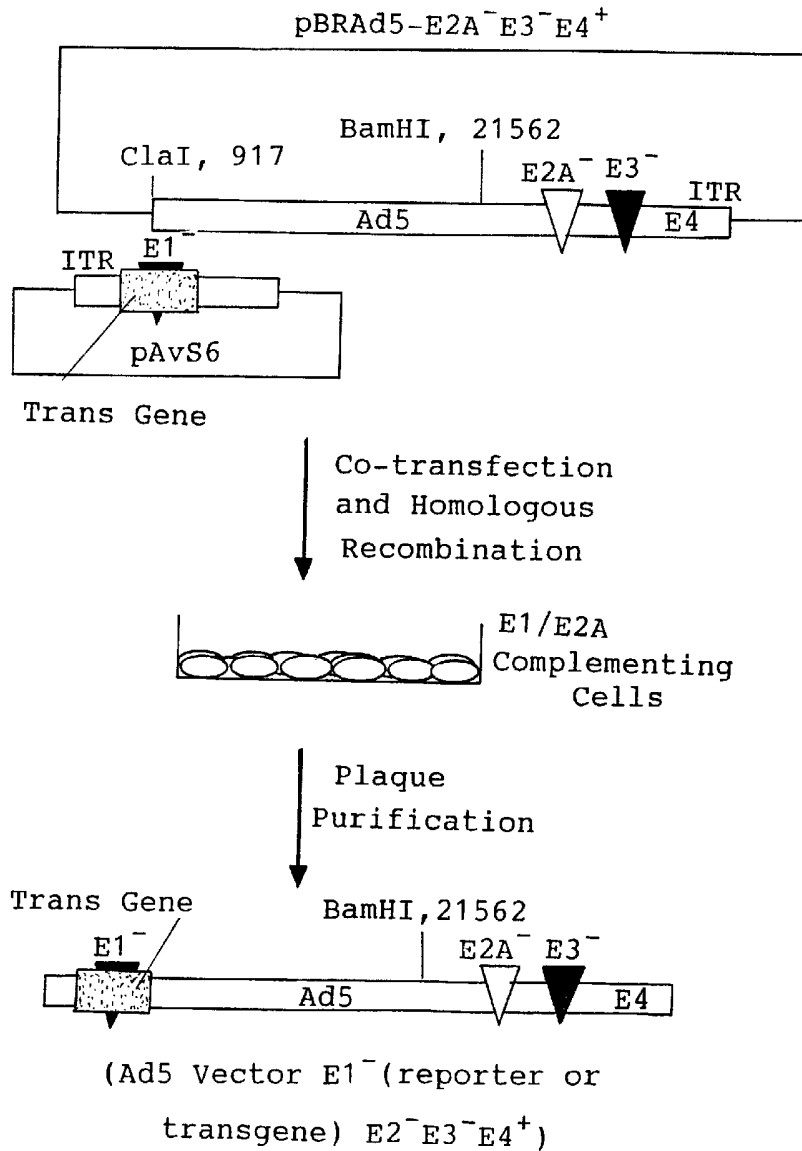

FIG. 27



SUBSTITUTE SHEET (RULE 26)

FIG. 28

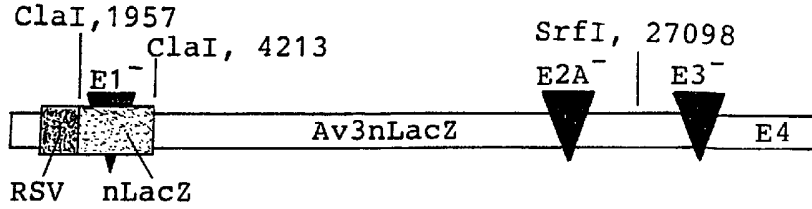

FIG. 24

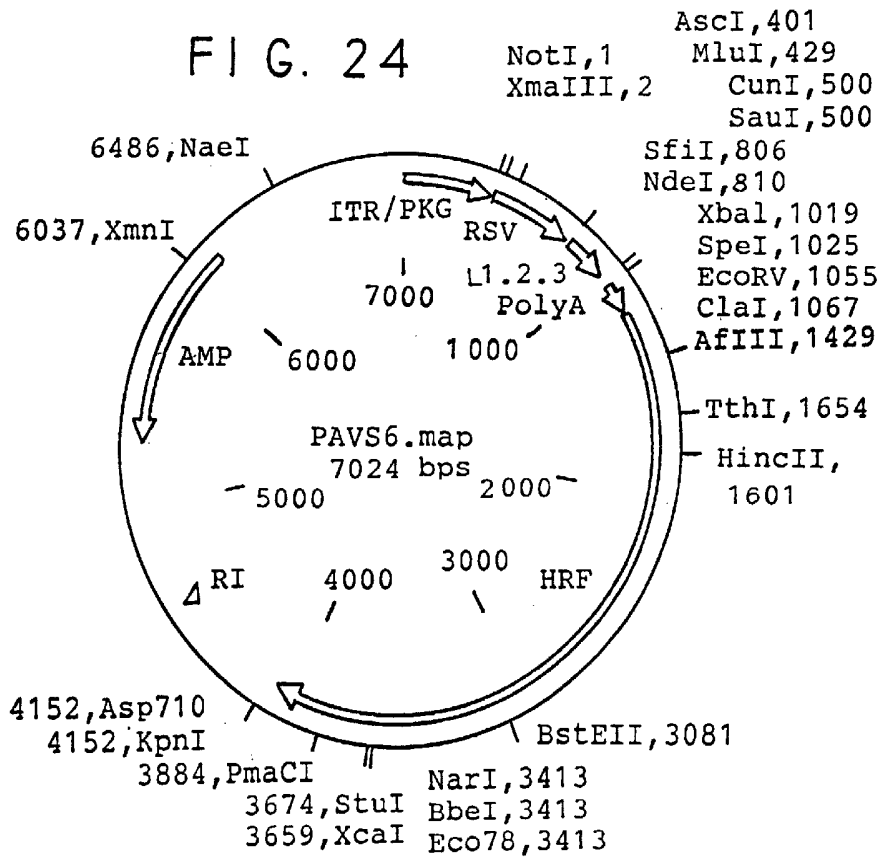

FIG. 29

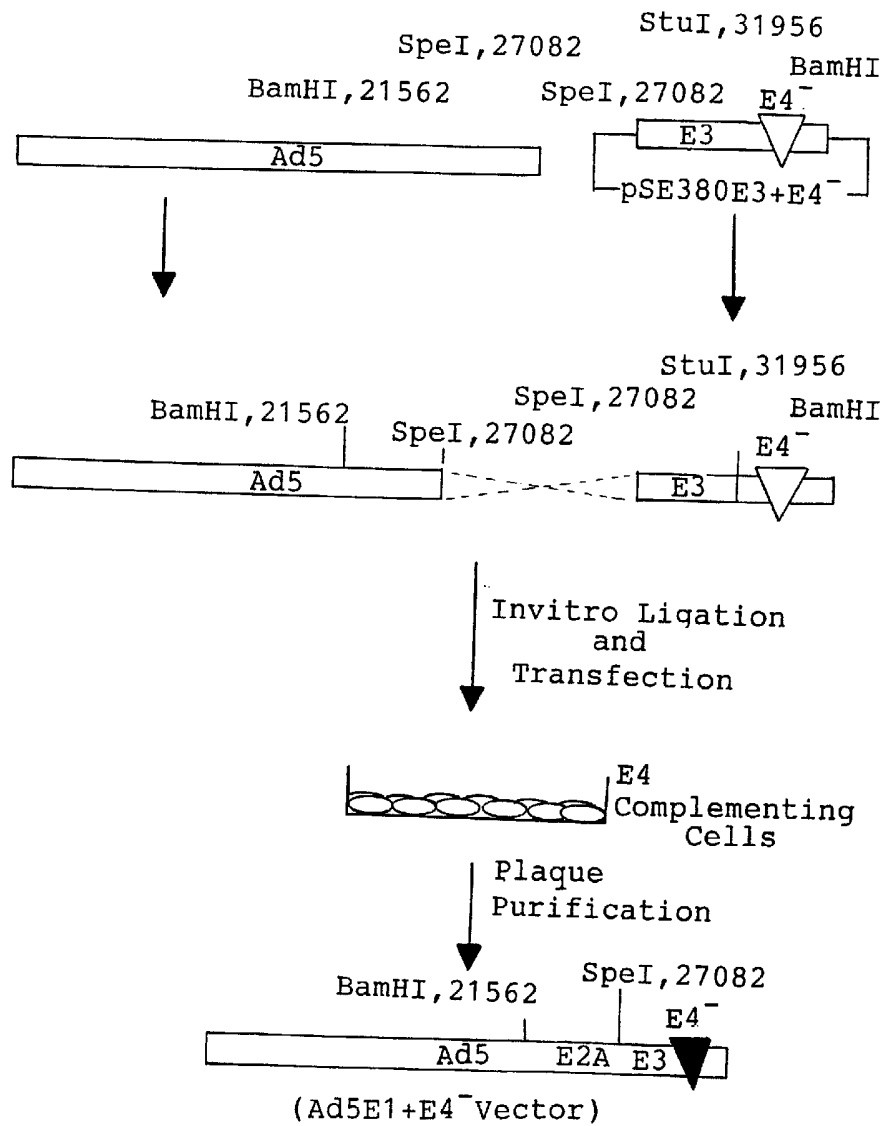
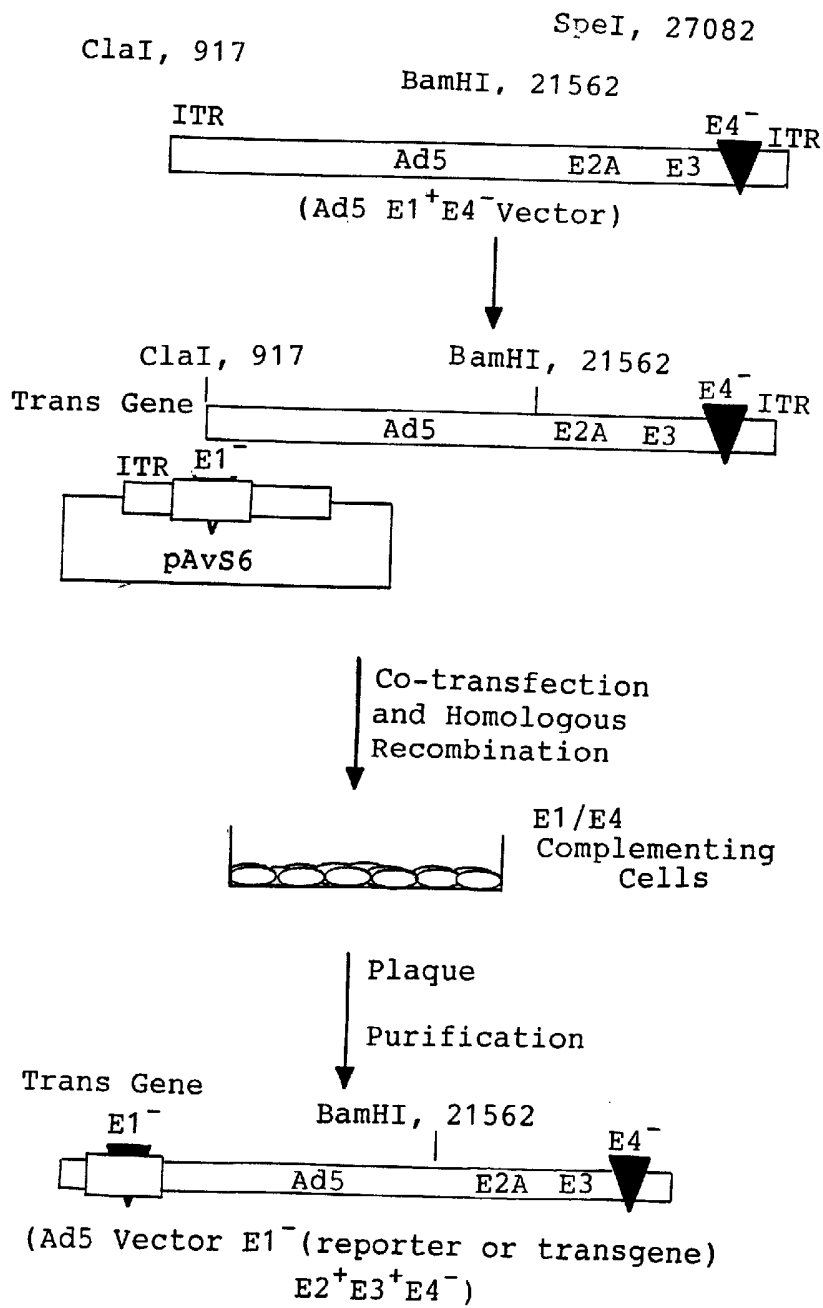

FIG. 30



SUBSTITUTE SHEET (RULE 26)

FIG. 31

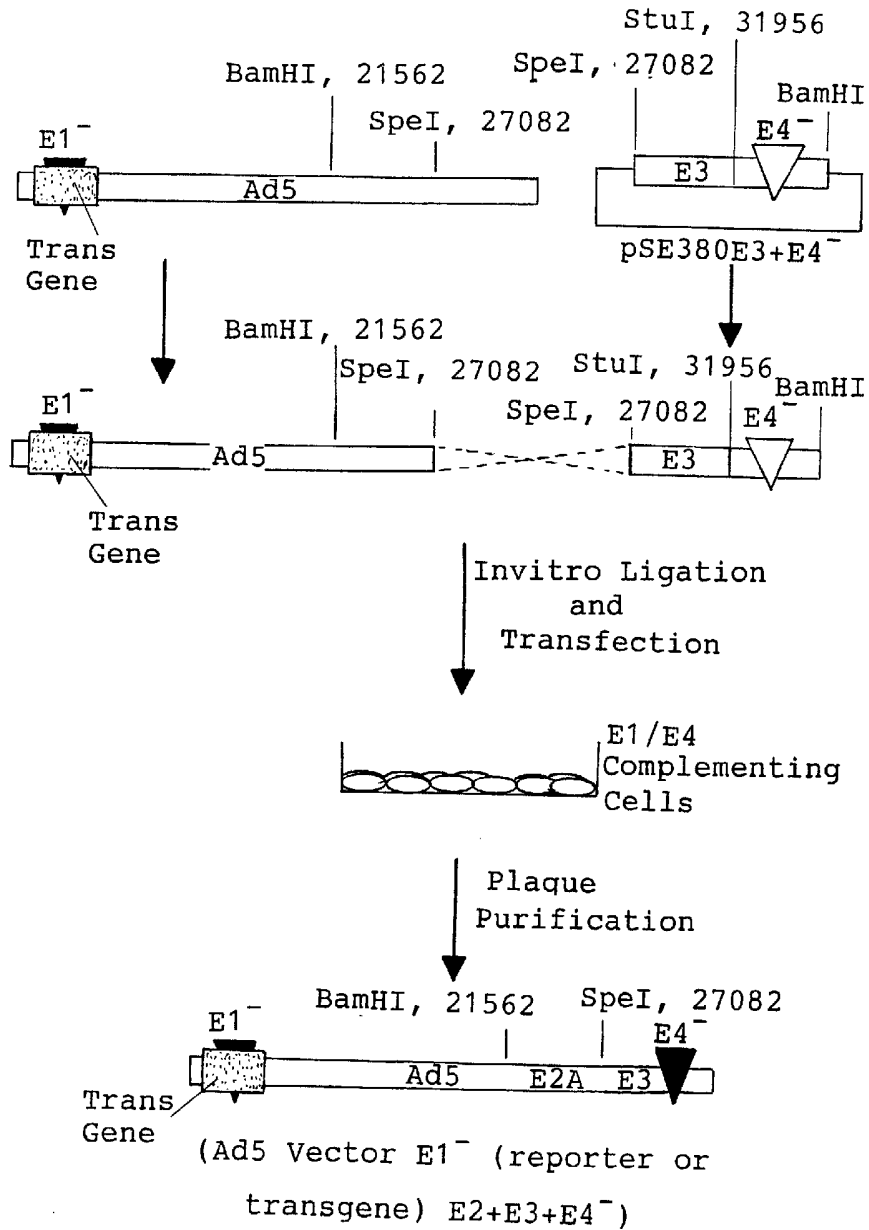

FIG. 32

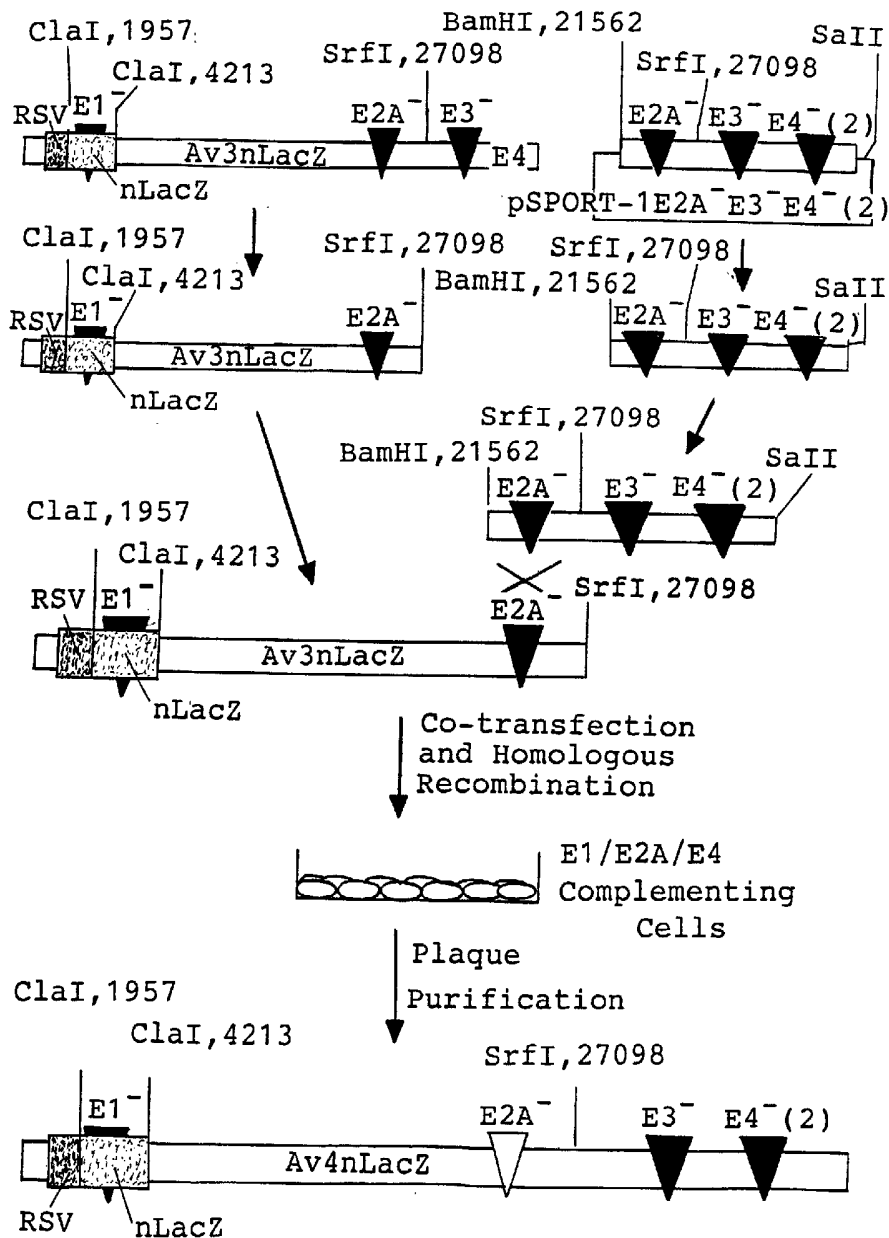

FIG. 33

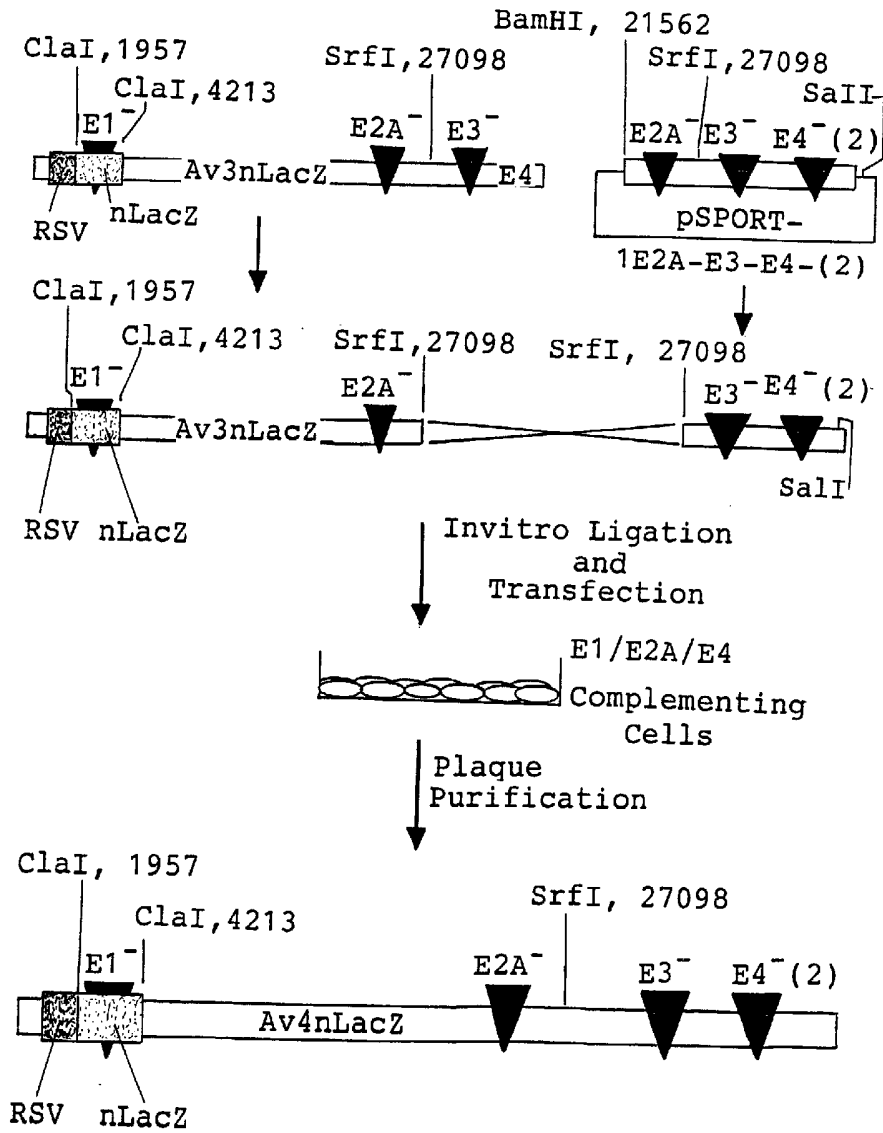

FIG. 34

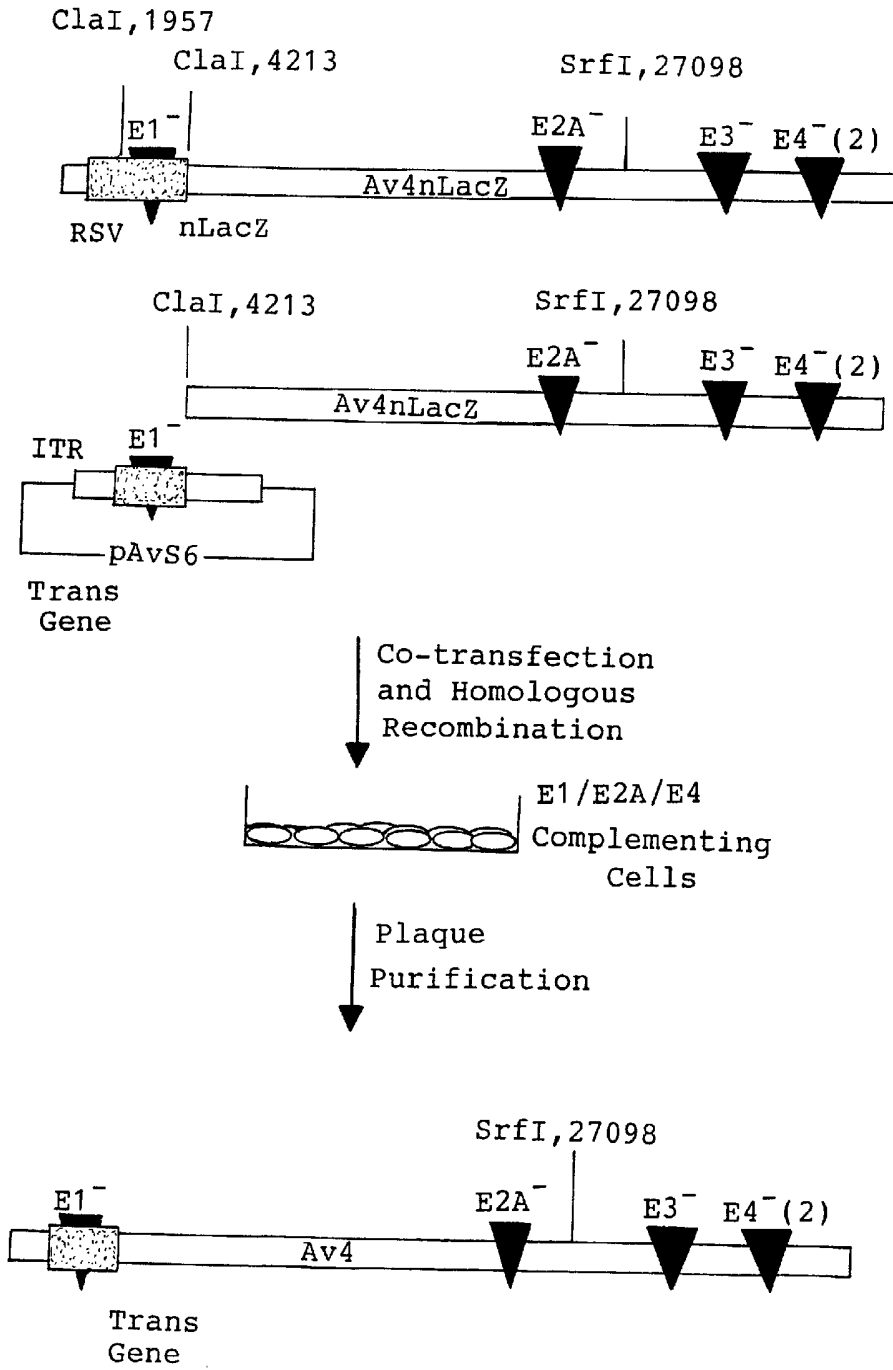
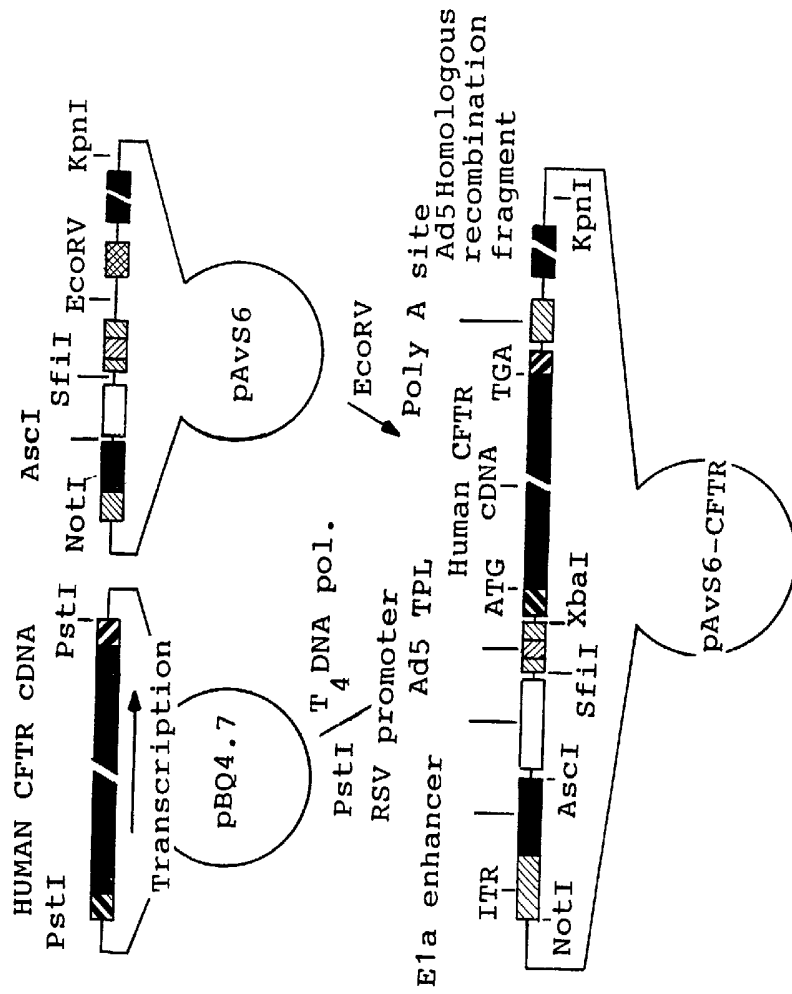

FIG. 35



Adenovirus Vector Hexon Expression in A549 Cells

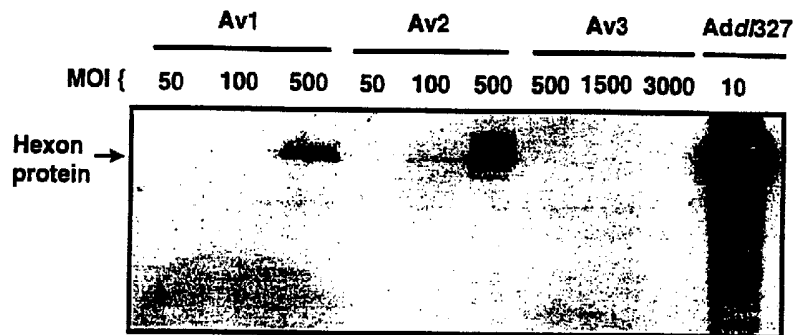

Fig. 36

Adenovirus Vector Hexon Expression

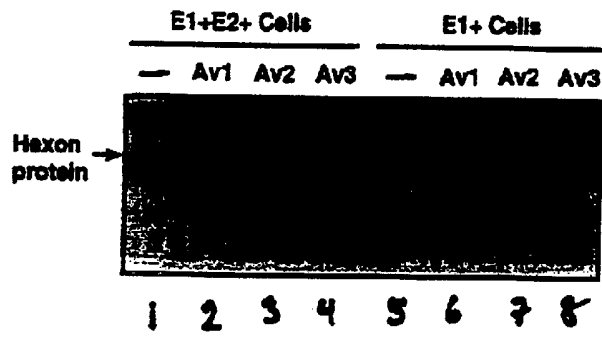

Figure 37

Adenovirus Vector DNA Replication

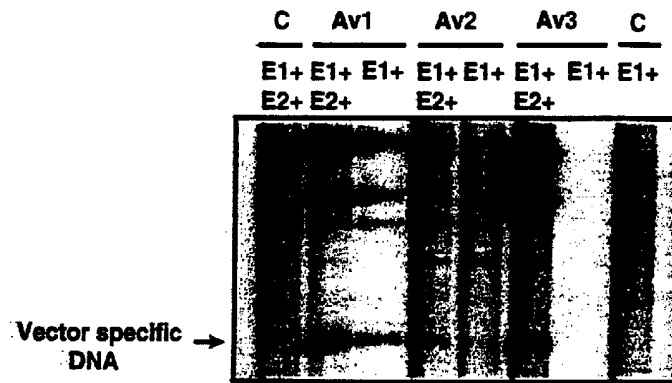

Fig. 38