

(12) PATENT
(19) AUSTRALIAN PATENT OFFICE

(11) Application No. AU 200073283 B2
(10) Patent No. 779293

(54) Title
An applicator for use in reflexotherapy

(51)⁷ International Patent Classification(s)
A61H 039/08 A61N 001/18

(21) Application No: **200073283**

(22) Application Date: **2000.07.13**

(87) WIPO No: **WO01/05351**

(30) Priority Data

(31) Number	(32) Date	(33) Country
99074080	1999.07.15	UA

(43) Publication Date : **2001.02.05**

(43) Publication Journal Date : **2001.04.26**

(44) Accepted Journal Date : **2005.01.13**

(71) Applicant(s)
Nikolai Grigorievich Lyapko

(72) Inventor(s)
Nikolai Grigorievich Lyapko

(74) Agent/Attorney
Griffith Hack,GPO Box 1285K,MELBOURNE VIC 3001

(56) Related Art
SU 1264942

(12) МЕЖДУНАРОДНАЯ ЗАЯВКА, ОПУБЛИКОВАННАЯ В СООТВЕТСТВИИ С
ДОГОВОРом О ПАТЕНТНОЙ КООПЕРАЦИИ (РСТ)(19) ВСЕМИРНАЯ ОРГАНИЗАЦИЯ
ИНТЕЛЛЕКТУАЛЬНОЙ СОБСТВЕННОСТИ
Международное бюро(43) Дата международной публикации:
25 января 2001 (25.01.2001)(10) Номер международной публикации:
WO 01/05351 A3

- (51) Международная патентная классификация⁷: A61N 39/08, A61N 1/18
- (21) Номер международной заявки: РСТ/UA00/00023
- (22) Дата международной подачи: 13 июля 2000 (13.07.2000)
- (25) Язык подачи: русский
- (26) Язык публикации: русский
- (30) Данные о приоритете: 99074080 15 июля 1999 (15.07.1999) UA
- (71) Заявитель и
(72) Изобретатель: ЛЯПКО Николай Григорьевич [UA/UA]; 85402 Донецкая обл., Марьинский район, Красногоривка, м-н Солнечный, д. 8, кв. 21 (UA) [LYAPKO, Nikolai Grigorievich, Krasnogorivka (UA)].
- (81) Указанные государства (национально): AL, AM, AT, AU, AZ, BA, BB, BG, BR, BY, CA, CH, CN, CU, CZ, DE, DK, EE, ES, FI, GB, GE, GH, GM, HU, ID, IL, IS, JP, KE, KG, KP, KR, KZ, LC, LK, LR, LS, LT, LU, LV, MD, MG, MK, MN, MW, MX, NO, NZ, PL, PT, RO, RU, SD, SE, SG, SI, SK, SL, TJ, TM, TR, TT, UA, UG, US, UZ, VN, YU, ZW.
- (84) Указанные государства (регионально): ARIPO патент (GH, GM, KE, LS, MW, MZ, SD, SL, SZ, TZ, UG, ZW), евразийский патент (AM, AZ, BY, KG, KZ, MD, RU, TJ, TM), европейский патент (AT, BE, CH, CY, DE, DK, ES, FI, FR, GB, GR, IE, IT, LU, MC, NL, PT, SE), патент OAPI (BF, BJ, CF, CG, CI, CM, GA, GN, GW, ML, MR, NE, SN, TD, TG).
- Опубликована
С отчётом о международном поиске.
- (88) Дата публикации отчёта о международном поиске: 14 июня 2001
- (74) Агент: КУКШИНА Татьяна Архиповна; 04215 Киев, а/я 67 (UA) [KUKSHINA, Tatyana Arkhipovna, Kiev (UA)].
- В отношении двухбуквенных кодов, кодов языков и других сокращений см. «Пояснения к кодам и сокращениям», публикуемые в начале каждого очередного выпуска Бюллетеня РСТ.

AN APPLICATOR

(54) Title: A NEEDLE FOR USE IN REFLEXOTHERAPY AND AN APPLICATOR USING THE SAME

(54) Название изобретения: ИГЛА ДЛЯ РЕФЛЕКСОТЕРАПИИ И ИСПОЛЬЗУЮЩИЙ ЕЁ АППЛИКАТОР

(57) Abstract: The inventive needle can be used for reflexotherapy (i.e. for acupuncture and acupressure by application) in health-care institutions or at home, whereby said needle can be contained in an applicator or used independently as an acupressure tool. The reflexotherapy needle (1) comprises a base having a stem (2), which has a tip (3) on one end, and is made of steel, copper, chrome, nickel or silver and has a coating of copper, chrome, nickel or silver. The novelty of the needle is in that the coating of the base of the needle (1) has a partial configuration, whereby a region (7) formed near the tip (3) thereof consists of at least two materials having different electrochemical potentials, and also in that the base and the coating are made from chemical elements selected in a group which also contains cobalt, aluminum, magnesium, zinc, tin, titanium, vanadium, beryllium, gold, platinum, palladium, strontium and tellurium as well as their alloys and oxides of the materials. The inventive needle provides for mechanical and electrical action in the area of interest of the patient's body and for a rational choice of materials used to form the base and the coating of the needle, which permits definition of a wide range of parameters of microcurrents; it offers more possibilities in the field of electrophoresis since it allows transportation of a wide range of microelements into the patient's body and intensifies electrophoresis as a result of such microcurrents. The invention also relates to the applicator using such a needle. Such an applicator allows for the creation in the epidermis of a complex heterogeneous dimensionally-shaped magnetic field which consists of microcurrents circulating between the needles themselves and between the bases and the coating of the needles; it allows for the definition of desired parameters of the microcurrents; for the restoration by electrophoresis of the evenness of the electrical field of the patient's skin, which has been disturbed by a disease; and for the introduction into the patient's body of a wider selection of microelements as well as allowing for the intensification of such a process for the introduction of microelements.

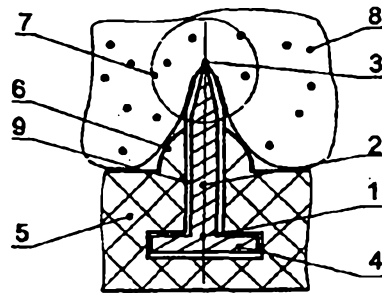

[Продолжение на след. странице]

WO 01/05351 A3



(57) Реферат:

Заявляемая игла может быть использована для рефлексотерапии (т.е. акупунктуры и аппликационной акупресури) в лечебных учреждениях и бытовых условиях, причем игла может быть использована как в составе аппликаторов, так и как отдельный инструмент для акупунктуры. Игла (1) для рефлексотерапии содержит основу, имеющую стержень (2) с острием (3) на одном конце и изготовленную из стали, меди, хрома, никеля или серебра, и с покрытием из хрома, никеля, меди или серебра. Новым в игле является то, что покрытие основы иглы (1) выполнено частичным с образованием вблизи ее острия (3) зоны (7), состоящей по меньшей мере из двух материалов с разными электрохимическими потенциалами, а основа и покрытие изготовлены из химических элементов, выбранных из группы, дополнительно включающей кобальт, алюминий, магний, цинк, олово, титан, ванадий, бериллий, золото, платину, палладий, стронций, теллур, а также их сплавы и оксиды материалов. Изобретение обеспечивает как механическое, так и электрическое действие иглы на соответствующую зону тела пользователя, целесообразный подбор материалов для основы иглы и покрытий для задания параметров микротоков, позволяет расширить возможности электрофореза за счет переноса в тело пользователя большего набора микроэлементов и усилить его интенсивность за счет микротоков. Заявляется также аппликатор, использующий такую иглу. Такой аппликатор обеспечивает создание в эпидерме пространственного сложного гетерогенного электрического поля из микротоков между иглами и микротоков между основами отдельных игл и их покрытиями, задание потребных параметров микротоков, выравнивание в результате электрофореза нарушенной болезнью равномерности электрического поля кожи пользователя, а также внесение в тело пользователя большего набора микроэлементов и интенсификацию процесса этого внесения.

user's body from the needles since the user's body is supplied only with microelements from the coatings together with an insignificant amount of microelements from the needle material due to the diffusion through the coatings. In addition, although such arrangement permits the use of
5 inexpensive, hard, and durable materials such as steel, copper, brass etc. to make the needles, and soft, expensive, and rare materials such as Sn, Au, Ag etc. for coatings, application of coating to the whole surface of needles will require rather substantial consumption of valuable materials.

Thus, the applicator disclosed in SU-A-1797889, and the applicator
10 provided with needles and disclosed in SU-A-1264942 generate electrical fields having uniform arrangement of lines of force but differing in planes of arrangement of such lines.

Brief Description of the Invention

15 The main object of the present invention consists in improving the applicator by way of providing exposure to the surface of the contact area between needles and user's epidermis of at least two materials having different electrochemical potentials, thereby providing generation of a three-dimensional complicated heterogeneous electrical field caused by interaction of galvanic
20 microcurrents flowing both between needles and between materials of individual needles and their coatings, and hence smoothing by way of electrophoresis the uniformity of electrical field of the user's epidermis, disturbed by a disease, as well as delivering of a greater set of microelements to the user's body, and intensifying the process of this delivery.

25 According to the present invention, there is provided an applicator for use in reflexotherapy comprising a base member; and a plurality of needles fixed within the base member, the needles comprising a rod, a sharpened portion and a head, the needles being partially covered with a coating, and including at least a first set of needles being made from and/or coated with a
30 first material and a second set of needles that are made from and/or coated with a second material, the first and second materials having different electrochemical potential; wherein the needles are partially covered with a coating to expose a surface of contact between each needle and a user's epidermis to at least two materials having different electrochemical potentials.

35 In contrast to prior art applicators, the inventive applicator ensures generation, in the epidermis, of galvanic microcurrents both between different

materials of each needle provided with a coating (i.e. between needle material and at least the material of a single-layer coating) and between the needles, the inventive applicator providing a higher number of microcurrents between the needles than the prior art applicator since each coated needle generates at least two microcurrents with each adjacent needle. Lines of force of the fields generated by these microcurrents extend in mutually perpendicular planes and interact with one another, thereby developing a three-dimensional complicated heterogeneous electrical field in the user's epidermis. Here, the heterogeneity of electrochemical condition of epidermis during interaction thereof with different materials of needle surfaces results in independent monitoring of microcurrent parameters between needles and between dissimilar materials of individual needles. As a result of application, high heterogeneity of the electrical field causes smoothing of electrical field uniformity of the user's epidermis, disturbed by a disease. At the same time, exposure to the surface of the contact area between needles and user's epidermis of two or more materials having different electrochemical potentials, also ensures transfer, to the user's body, of a greater set of microelements since microelements are transferred to the user's body both from the needle base materials and from coatings), and improves the intensity of such transfer.

It is expedient to make partial coatings of needles multilayer, thereby ensuring the exposure to the surface of the area of contact between each needle provided with such coating and epidermis of several materials having different electrochemical potentials, which in turn increases the number of various microcurrents in the user's epidermis, said microcurrents flowing both between materials of individual needles and between needles, and providing the contact between epidermis and several materials of individual needles, and hence increasing heterogeneity of the resulting electrical field and expanding the set of microelements transferred from needle materials and their coating layers to the user's body.

It is also expedient to arrange needles in the applicator in such way that adjacent needles comprise different materials exposed to the surface of their areas of contact with the user's epidermis.

Brief Description of Drawings

The invention is further described in more detail in terms of specific embodiments thereof, and with reference to the accompanying drawings, in which:

Fig.1 shows a cross-section of a fragment of the inventive applicator, comprising a needle provided with a single-layer coating with the exception of the sharpened portion thereof, said needle interacting with the user's epidermis;

Figs 2 and 3 demonstrate schematic drawings of stripped sharpened portion of the needle shown in Fig.1;

Fig.4 shows schematic drawing of generation of galvanic microcurrent in the epidermis between the material and the coating of the needle in shown Fig.1;

Fig.5 demonstrates schematic drawing of the needle provided with the coating only on the sharpened portion thereof;

Fig.6 shows schematic drawing of the needle provided with coated sharpened portion and exposed apex of this portion;

Fig.7 demonstrates schematic drawing of the needle provided with a two-layer coating applied to the needle except the sharpened portion thereof;

Fig.8 shows schematic drawing of the needle provided with a single-layer coating, and the coating applied to the sharpened portion on top of the first layer;

Fig.9 demonstrates schematic drawing of the needle provided with a single-layer coating, a coating applied to the sharpened portion on top of the first layer, and exposed apex of the sharpened portion;

Fig.10 shows schematic drawing of the needle provided with a triple-layer coating of the needle base, a coating applied to the sharpened portion on top of the above three layers, and exposed apex of the sharpened portion;

Fig.11 demonstrates top view of a fragment of the schematic drawing of the inventive applicator;

Fig.12 shows section A-A of the applicator of the invention, shown in Fig.11.

Preferred Embodiment of the Invention

Needle 1 of the applicator (Fig.1) comprises rod member 2 provided with sharpened portion 3 at one end and head 4 at the other end thereof. Needle 1 is fixed in base member 5 of the applicator so that its part provided with sharpened portion 3 protrudes above surface 6 of base member 5. Area 7 close to sharpened portion 3, i.e. the area of contact between needle 1 and user's epidermis 8,

occupies the side surface of needle 1 from sharpened portion 3 to surface 6 or a portion of this surface, depending on required depth of penetration of needle 1 into epidermis 8, said depth depending on a pressure acting on the applicator, density of needles arrangement and sharpness of their sharpened portions, area 7 including at least two materials having different electrochemical potentials and exposed to the needle surface: material of needle 1 base and material of layer 9 of the coating applied to needle 1 except sharpened portion 3 thereof (except sharpened portion 3 or a part thereof, or except sharpened portion 3 and a part of rod 2 close to sharpened portion 3 since it is rather difficult to coating the whole rod with exact exception of sharpened portion 3). Needle 1 is made of iron or steel, and layer 9 of the coating may be made e.g. of nickel, chromium, zinc, or copper. Needle 1 may be also made of copper or copper alloy, e.g. brass, and layer 9 of the coating may consist of nickel, chromium, or silver. Here, it is expedient to coating nickel with chromium. The coating may be applied with the use of various methods such as dipping, spraying, or galvanising.

It is expedient to apply layer 9 of the coating to whole needle 1, including sharpened portion 3 thereof, and then to strip sharpened portion 3 by removing the coating e.g. by grinding off coating 9 next to sharpened portion 3 to form a cone (Fig.2), said grinding off being carried out over conical surface 10 with removal of part 11 of layer 9, or by cutting off the coating over plane 10 (Fig.3) with removal of part 11 of layer 9.

Upon penetration of needle 1 (Fig.4) into the user's epidermis 8 comprising a liquid ionised constituent, the difference of electrochemical potentials between the material of needle 1 and the material of layer 9 of the coating results in generation of galvanic microcurrent G, in formation of a galvanic cell with electrodes represented by material of needle 1 and layer 9 of the coating, and electrolyte represented by the liquid ionised part of epidermis 8. Mechanical irritation of epidermis 8, caused by penetration of needle 1, is accompanied by the action on the epidermis of the electrical field generated by galvanic microcurrent G. In addition, there occurs transfer to epidermis 8 of microelements both from sharpened portion 3 of the needle and from layer 9 of the coating, such transfer being considerably intensified through the presence of galvanic microcurrent G, thereby increasing the effects of both reflexotherapy and electrophoresis, said

effects being both qualitative (two types of microelements) and quantitative (more intense transfer of microelements).

Fig.5 demonstrates needle 1 provided with layer 12 of the coating applied to sharpened portion 31. Needle 1 and coating 12 may be made of the same materials as specified in the previous embodiment of needle 1. This embodiment of needle 1 is the most expedient when applying coatings of precious and rare materials such as platinum, gold, silver, tellurium etc., since such arrangement results in considerable decrease of their consumption (these metals are used only for coating sharpened portion 3 rather than whole needle 1).

When removing the coating from a part of sharpened portion 3 (Fig.6), two galvanic couples are formed: between apex 13 of sharpened portion 3 of needle 1 and coating 14 (galvanic microcurrent G_1), and between coating 14 and rod 2 (galvanic microcurrent G_2).

The area of contact between needle 1 and user's epidermis 8 (Fig.7) may be composed of the material of needle 1 and several, e.g. two layers 15 and 16 of coating, stripped close to sharpened portion 3 of needle 1. In this case, three different galvanic couples are formed: layer 15 of coating – sharpened portion 3 (galvanic microcurrent G_3); layer 16 – sharpened portion 3 (galvanic microcurrent G_4), and layer 15 – layer 16 (galvanic microcurrent G_5). This fact further intensifies electrical action of the applicator and provides transfer of microelements to epidermis 8 from all the three materials: needle 1 and layers 15 and 16. It should be also noted that transfer of microelements from rod 2 and layer 15, through layer 16 and into the user's epidermis 8 is also carried out due to diffusion, the amount of this transfer being substantial as a result of large contact area between rod 2 and layer 15, between layers 15 and 16, and between layer 16 and epidermis 8. Needle 1 may be provided with still more layers of coating, which fact results in intensification of the action caused by electrical fields and permits to transfer a greater number of various microelements to epidermis 8.

The area of contact between needle 1 and epidermis 8 may be composed (Fig.8) of one coating layer 17 applied to the whole needle 1, and coating layer 18 applied on the top of layer 17 on sharpened portion 3 of needle 1. In this case, layer 17 – layer 18 galvanic couple is formed (galvanic microcurrent G_6), and transfer of microelements from the material of needle 1 and layers 17, 18 occurs by diffusion, due to a larger area of contact between all the surfaces.

The above-disclosed embodiment of the invention may be somewhat modified if sharpened portion 3 is stripped to remove layers 17, 18, e.g. by way of grinding them off (Fig.9) (or due to quick wear during the use of applicator). In this case, galvanic microcurrent G_6 between layers 17, 18 is supplemented by galvanic microcurrent G_7 between layer 17 and sharpened portion 3, and galvanic microcurrent G_8 between layer 18 and sharpened portion 3. This intensifies the electrical action of needle 1 on epidermis 8 and transfer of microelements from the material of needle 1 and coating layers 17, 18.

Needle 1 may be provided with a multilayer coating, comprising e.g. layers 19, 20, 21 applied to the whole needle, and layer 22 applied only to sharpened portion 3 thereof. All these layers are cut away along plane 23, each layer being exposed to the surface of needle 1. This results in the formation of five different galvanic microcurrents (not shown), leading to a considerable intensification of the electrical action of needle 1 on epidermis 8, and transfer of four various microelements thereto.

One or more layers of coating may be applied by spraying that results in formation of loose or dense layers. Loose layers of coatings increase the flow of microelements passing therethrough.

The order of location of materials on the needle, in the direction from the needle material and toward the external layer, may be e.g. the following:

Fe (steel) – Ni – Cu (or Pt, or Pd, or Au) – Ag;

Fe – Ni – Au;

Fe – Cr – Au;

Fe – Cr (or Ag, or Cu) – Cu (or Pt);

Fe – Zn – Cr;

Cu – Ag;

Cu – Ni – Cr.

The needles are made of Fe or Cu or alloys thereof, e.g. steel or brass. They may be provided with coating layers of all the above metals in the above-specified order, e.g. first layer of nickel, second layer of copper (or platinum, or palladium, or gold), and third layer of silver. Copper or brass base may be coated with silver, gold, platinum, palladium, and nickel with a thin layer of chromium.

As shown in Figs 11, 12, the inventive applicator preferably comprises base member 5 with needles 24-32 fixed therein, at least a portion of needles 24-32 being provided with partial single- or multilayer coatings with exposure to the surface of the areas of contact between the needles and user's epidermis 8 of at least two materials having different electrochemical potentials. Needles 24-32 are made of different materials and provided with coatings located e.g. in the following order: one row 33 consists of solid copper needle 24; steel needle 25 provided with nickel coating and exposed sharpened portion 3; needle 26 made of steel or iron and provided with solid copper coating layer 36 and silver (or gold, or platinum, or palladium) coating layer 37 on sharpened portion 3; needle 27 made of iron or steel provided with double-layer coating of zinc and chromium, and exposed sharpened portion 3; needle 28 made of copper and provided with silver (or gold, or platinum, or palladium) coating on sharpened portion 3 etc. Another row 38 consists of copper or brass needle 29 provided with double-layer coating of nickel and chromium; copper needle 24; iron or steel needle 30 provided with double-layer coating of zinc and chromium; steel needle 31; copper or brass needle 32 provided with copper coating over the whole needle except sharpened portion 3 thereof etc. In subsequent rows, the order of location can be either similar or different; the critical point consists in that each needle has to be surrounded by needles whose materials and coatings are different. Such arrangement accelerates electrophoresis and provides smoothing, as a result of reflexotherapy, of the natural heterogeneity of the electrical field of epidermis.

The applicator operates as follows:

Penetration of needles 24-32 into epidermis 8 generates the effect of mechanical irritation of a selected area of the user's body surface. At the same time, within the area of contact between needles 25, 26, 27, 28, 29, 30, 32 and the epidermis, galvanic microcurrents G_B are generated (said microcurrents have been disclosed herein for various embodiments of needles); these microcurrents are flowing in the planes of needle axes and causing the effect of weak electrical fields on the user's epidermis 8. In addition, different electrical potentials of various needles cause generation of galvanic microcurrents G_r between materials of adjacent needles and their coatings, flowing in the planes perpendicular or inclined to the planes of microcurrent flows between materials of individual needles. Microcurrents G_r interact with microcurrents G_B generated by individual needles,

thereby generating a three-dimensional complicated heterogeneous electrical field in the user's epidermis 8. Various microelements are transferred from needles 24-32 into epidermis 8, the intensity of their transfer to epidermis 8 being amplified by microcurrents flowing therein. Due to diversity of electrobiochemical conditions of epidermis 8 during interaction thereof with materials of needle surfaces, epidermis 8 performs automatic adjustment of microcurrent and electrophoresis parameters.

Arrangement of needles in the applicator, as well as needle and coating materials are selected depending on the desired action of the applicator on selected areas of user's bodies (required intensity of mechanical action, electrical field parameters, and saturation with certain microelements).

In the simplest case, two kinds of needles, e.g. copper (brass) or steel, and needles having single type of coating/coatings may be used.

The needles may be also arranged in rows, each row being formed by the needles made of the same or similar materials, and differing by needle materials from the needles in other rows, thereby causing generation of a more homogeneous electrical field.

To manufacture needles and coatings, the use can be made of chemical elements selected from the group comprising copper, iron, nickel, chromium, cobalt, aluminium, magnesium, zinc, tin, silver, titanium, vanadium, beryllium, gold, platinum, palladium, strontium, tellurium, as well as alloys and oxides thereof. This permits to produce durable and inexpensive needles provided with coatings of small quantities of precious and rare materials, to expand the set of materials used, and hence to provide numerous galvanic couples generating a variety of microcurrents having various parameters. This also permits the transfer of numerous microelements into the user's body.

It is to be understood that, if any prior art publication is referred to herein, such reference does not constitute an admission that the publication forms a part of the common general knowledge in the art, in Australia or any other country.

In the claims which follow and in the preceding description of the invention, except where the context requires otherwise due to express language or necessary implication, the word "comprise" or variations such as "comprises" or "comprising" is used in an inclusive sense, i.e. to specify the presence of the stated features but not to preclude the presence or addition of further features in various embodiments of the invention.

THE CLAIMS DEFINING THE INVENTION ARE AS FOLLOWS:

1. An applicator for use in reflexotherapy comprising:
a base member; and
5 a plurality of needles fixed within the base member, the needles comprising a rod, a sharpened portion and a head, the needles being partially covered with a coating, and including at least a first set of needles being made from and/or coated with a first material and a second set of needles that are made from and/or coated with a second material, the first and second materials
10 having different electrochemical potential;
wherein the needles are partially covered with a coating to expose a surface of contact between each needle and a user's epidermis to at least two materials having different electrochemical potentials.
- 15 2. An applicator according to claim 1, comprising at least one further set of needles made from and/or coated with a further material having different electrochemical potential to the first and/or second set of needles.
- 20 3. An applicator according to claim 1 or 2, in which the coating on at least some of the needles comprise a multilayer coating.
- 25 4. An applicator according to any one of the preceding claims, in which the needles are disposed in the applicator in a configuration in which each adjacent needles exposed to the surface of contact areas with the user's epidermis are either coated with and/or made from different materials.
- 30 5. An applicator according to any one of the preceding claims, in which the material comprising the needles and/or coatings is selected from steel, copper, chromium, nickel, silver, cobalt, aluminium, magnesium, zinc, tin, titanium, vanadium, beryllium, gold, platinum, palladium, strontium, tellurium or alloys and oxides thereof.
6. An applicator according to any one of the preceding claims when used for reflexotherapy.

7. An applicator for use in reflexotherapy substantially as herein before described with reference to the accompanying drawings.

5

Dated this 17th day of November 2004

NIKOLAI GRIGORIEVICH LYAPKO

By their Patent Attorneys

GRIFFITH HACK

10

Fellows Institute of Patent and

Trade Mark Attorneys of Australia

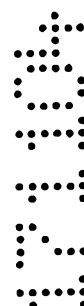
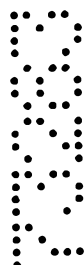

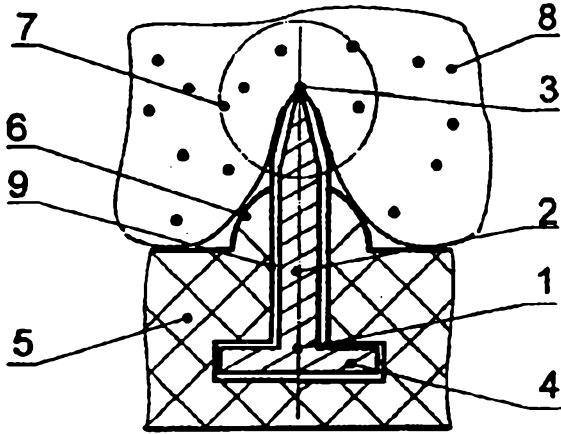

Фиг. 1

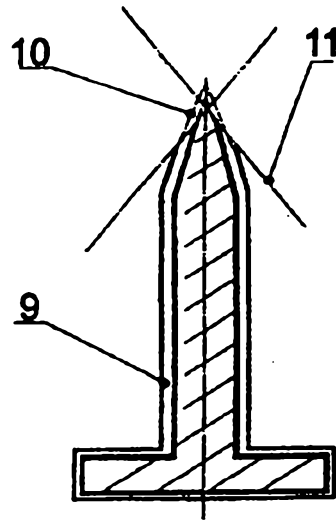

Фиг. 2

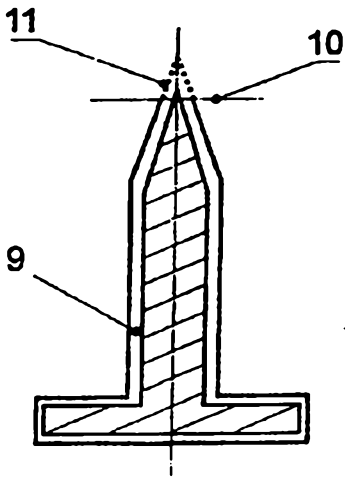

Фиг. 3

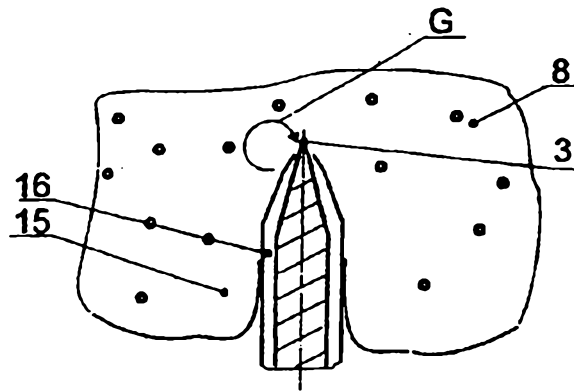

Фиг. 4

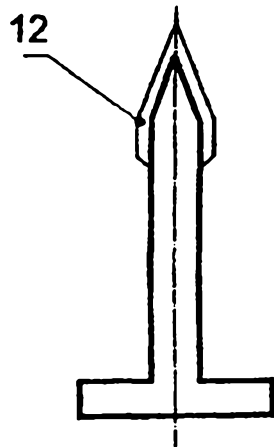

Фиг. 5

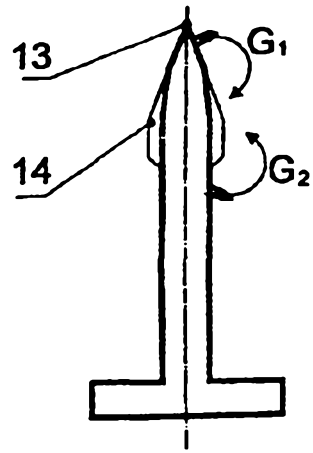

Фиг. 6

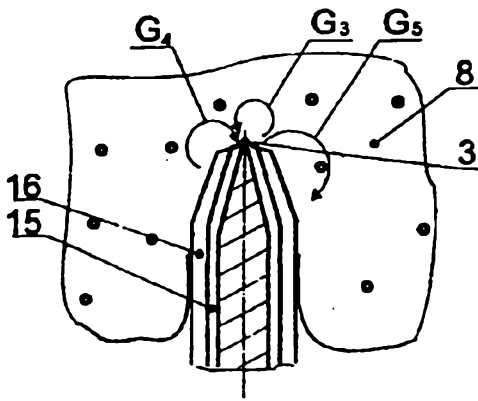

Фиг. 7

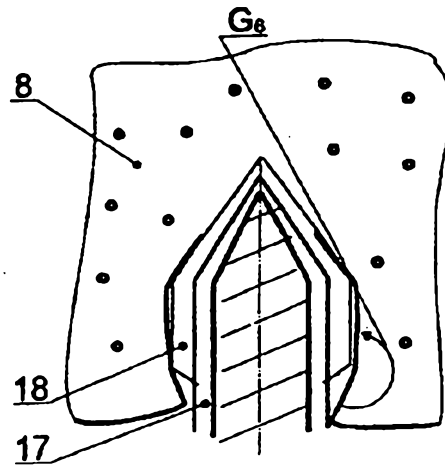

Фиг. 8

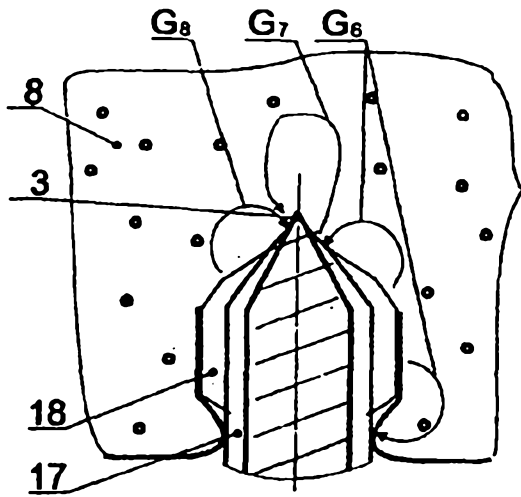

Фиг. 9

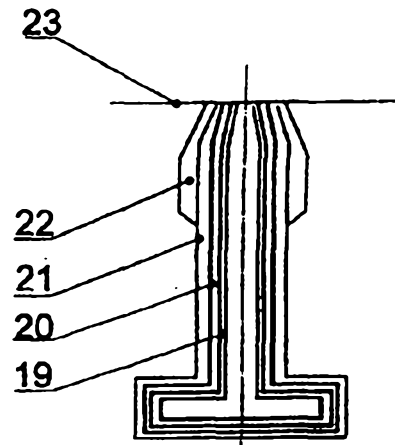

Фиг. 10

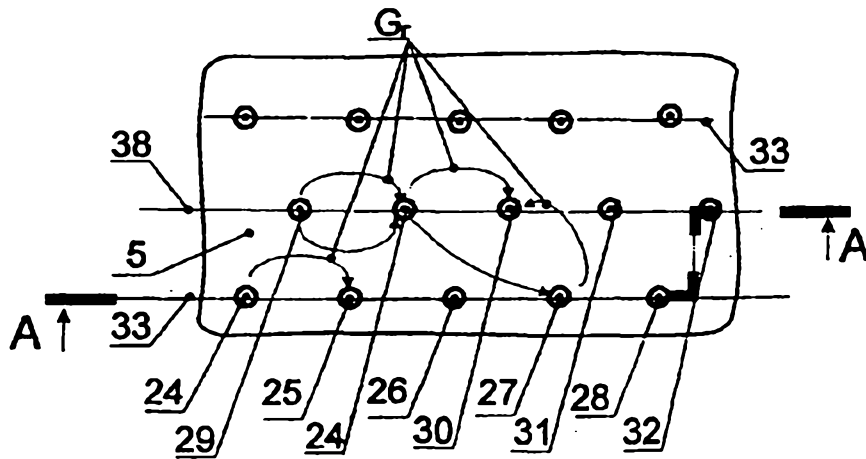

Фиг. 11

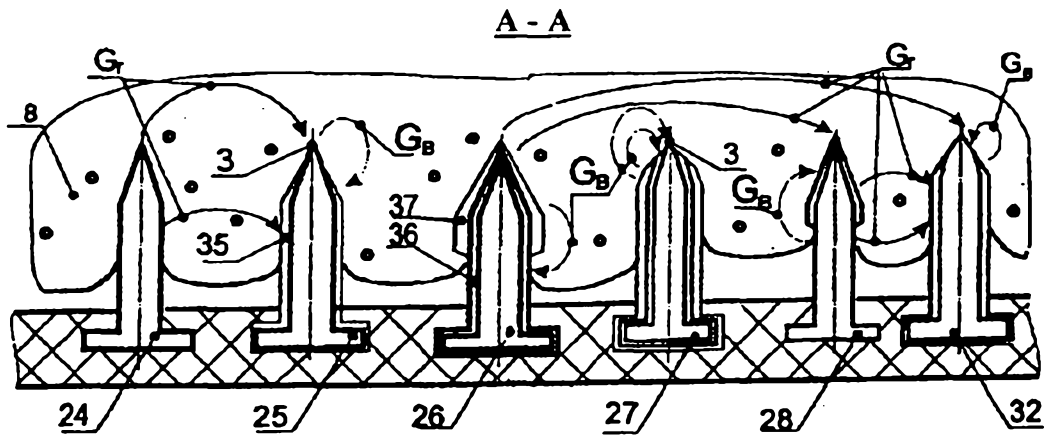

Фиг. 12