

(12) STANDARD PATENT
(19) AUSTRALIAN PATENT OFFICE

(11) Application No. **AU 2012372806 B2**

(54) Title
High pressure ratio multi-stage centrifugal compressor

(51) International Patent Classification(s)
F25B 13/00 (2006.01)

(21) Application No: **2012372806**

(22) Date of Filing: **2012.03.08**

(87) WIPO No: **WO13/133832**

(43) Publication Date: **2013.09.12**

(44) Accepted Journal Date: **2015.12.10**

(71) Applicant(s)
Danfoss A/S

(72) Inventor(s)
Sun, Lin;Brasz, Joost

(74) Agent / Attorney
Watermark Patent and Trade Marks Attorneys, 302 Burwood Road, Hawthorn, VIC, 3122

(56) Related Art
US 4739628



(51) International Patent Classification:
F25B 13/00 (2006.01)

(21) International Application Number:
PCT/US2012/028221

(22) International Filing Date:
8 March 2012 (08.03.2012)

(25) Filing Language: English

(26) Publication Language: English

(71) Applicant (for all designated States except US): **DAN-FOSS TURBOCOR COMPRESSORS B.V.** [US/NL]; Koningslaan 17, NL-1075 AA Amsterdam (NL).

(72) Inventors; and

(75) Inventors/Applicants (for US only): **SUN, Lin** [CA/US]; 8332 Inverness Drive, Tallahassee, Florida 32312 (US). **BRASZ, Joost** [NL/US]; 1 Landgrove Drive, Fayetteville, New York 13066 (US).

(74) Agent: **GOTTSCHALK, William S.**; Carlson, Gaskey & Olds, P.C., 400 West Maple, Suite 350, Birmingham, Michigan 48009 (US).

(81) Designated States (unless otherwise indicated, for every kind of national protection available): AE, AG, AL, AM, AO, AT, AU, AZ, BA, BB, BG, BH, BR, BW, BY, BZ, CA, CH, CL, CN, CO, CR, CU, CZ, DE, DK, DM, DO,

DZ, EC, EE, EG, ES, FI, GB, GD, GE, GH, GM, GT, HN, HR, HU, ID, IL, IN, IS, JP, KE, KG, KM, KN, KP, KR, KZ, LA, LC, LK, LR, LS, LT, LU, LY, MA, MD, ME, MG, MK, MN, MW, MX, MY, MZ, NA, NG, NI, NO, NZ, OM, PE, PG, PH, PL, PT, QA, RO, RS, RU, RW, SC, SD, SE, SG, SK, SL, SM, ST, SV, SY, TH, TJ, TM, TN, TR, TT, TZ, UA, UG, US, UZ, VC, VN, ZA, ZM, ZW.

(84) Designated States (unless otherwise indicated, for every kind of regional protection available): ARIPO (BW, GH, GM, KE, LR, LS, MW, MZ, NA, RW, SD, SL, SZ, TZ, UG, ZM, ZW), Eurasian (AM, AZ, BY, KG, KZ, MD, RU, TJ, TM), European (AL, AT, BE, BG, CH, CY, CZ, DE, DK, EE, ES, FI, FR, GB, GR, HR, HU, IE, IS, IT, LT, LU, LV, MC, MK, MT, NL, NO, PL, PT, RO, RS, SE, SI, SK, SM, TR), OAPI (BF, BJ, CF, CG, CI, CM, GA, GN, GQ, GW, ML, MR, NE, SN, TD, TG).

Declarations under Rule 4.17:

— of inventorship (Rule 4.17(iv))

Published:

— with international search report (Art. 21(3))

(88) Date of publication of the international search report:

3 April 2014

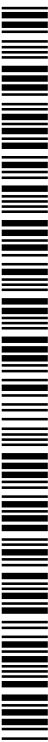

WO 2013/133832 A3

(54) Title: HIGH PRESSURE RATIO MULTI-STAGE CENTRIFUGAL COMPRESSOR

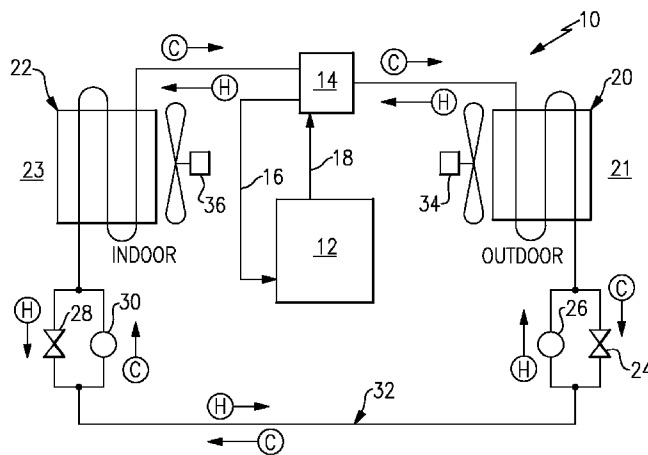

FIG.1

(57) Abstract: A heat pump system includes a refrigerant circuit. First and second heat exchangers are arranged in the refrigerant circuit. A flow reversing device selectively changes a direction of flow in the refrigerant circuit between the first and second heat exchangers. A centrifugal compressor is arranged in the fluid circuit and has first and second impellers arranged in series relative to one another to provide a desired compressor pressure ratio. In one example, the centrifugal compressor mounts the first and second impellers on opposing ends of a shaft. The first and second impellers respectively include first and second stage inlets and outlets. One example desired compressor pressure ratio of at least 10:1 corresponds to a second stage outlet pressure to a first stage inlet pressure. A first diffuser is arranged at the first stage outlet, and the first diffuser is a variable geometry diffuser.

HIGH PRESSURE RATIO MULTI-STAGE CENTRIFUGAL COMPRESSOR

BACKGROUND

[0001] This disclosure relates to a multi-stage centrifugal compressor for use in a high pressure ratio multi-stage centrifugal compressor having at least one variable geometry diffuser.

[0002] Existing single-stage and two-stage centrifugal refrigeration compressors, with vaneless or vaned diffusers, typically have at least one set of variable inlet guide vanes at a compressor inlet to regulate compressor capacity during various operating conditions.

[0003] Variable-speed centrifugal compressors use speed variation as their primary capacity control mechanisms, but such compressors still need variable inlet guide vanes in order to operate surge-free at low capacity conditions.

[0004] Multi-stage centrifugal compressors have used stages with fixed, typically vaneless, diffusers with inlet guide vanes and variable speed as the capacity control mechanism. Single-stage refrigerant compressors have been introduced that employ a variable frequency drive (VFD) for capacity control in addition to a set of rotatable inlet guide vanes upstream of the impeller. In the case of a variable speed capability, a variable-geometry diffuser has been used downstream from the impeller to improve the compressor surge characteristics at part-load operating conditions.

[0005] Heat pump systems require compressors having high pressure ratios. Typically, screw-type or scroll-type compressors are used provide the needed high pressures of heat pump systems.

SUMMARY

[0006] A heat pump system includes a refrigerant circuit. First and second heat exchangers are arranged in the refrigerant circuit. A flow reversing device selectively changes a direction of flow in the refrigerant circuit between the first and second heat exchangers. A

centrifugal compressor is arranged in the fluid circuit and has first and second impellers arranged in series relative to one another to provide a desired compressor pressure ratio.

[0007] In one example, the centrifugal compressor mounts the first and second impellers on opposing ends of a shaft. The first and second impellers respectively include first and second stage inlets and outlets. One example desired compressor pressure ratio of at least 10:1 corresponds to a second stage outlet pressure to a first stage inlet pressure. A first diffuser is arranged at the first stage outlet, and the first diffuser is a variable geometry diffuser.

BRIEF DESCRIPTION OF THE DRAWINGS

[0008] The disclosure can be further understood by reference to the following detailed description when considered in connection with the accompanying drawings wherein:

[0009] Figure 1 is a highly schematic view of a heat pump system having an example centrifugal compressor with multiple stages.

[0010] Figure 2 is a cross-sectional view of an example two-stage centrifugal compressor of this disclosure.

[0011] Figure 3 is a schematic view of an economizer for the disclosed centrifugal compressor.

[0012] Figure 4 is a schematic view of one example variable geometry diffuser for the disclosed centrifugal compressor.

DETAILED DESCRIPTION

[0013] Referring to Figure 1, a heat pump system 10 includes a centrifugal compressor 12 for circulating a refrigerant in a refrigerant circuit 32. The centrifugal compressor 12 is arranged in the fluid circuit 32 and includes compressor inlet and outlet passages 16, 18 that are in fluid communication with a flow reversing device 14. The example heat pump system is exemplary of a high pressure ratio system. It should be understood the disclosed centrifugal compressor may be used in other high pressure ratio applications, such as certain air-cooled chiller or refrigeration systems.

[0014] First and second heat exchangers 20, 22 are fluidly arranged in the refrigerant circuit 32 and respectively arranged at first and second locations 21, 23, which may be indoors and outdoors in one example. In the example, blowers 34, 36 are respectively associated with each heat exchanger for transferring heat between each heat exchanger and its surrounding environment. It should be understood, however, that although refrigerant-to-air heat exchangers are shown, a heat exchanger may be used that transfers heat between the refrigerant and another fluid, such as water.

[0015] The flow reversing device 14 selectively changes the direction of flow in the refrigerant circuit 32 between the first and second heat exchangers 20, 22. In the example arrangement, an “H” depicts a heating direction of refrigerant flow, and a “C” shows a cooling direction of refrigerant flow.

[0016] A first bypass valve 24 and a first thermal expansion valve 26 are associated with the first heat exchanger 20. A second bypass valve 28 and a second thermal expansion valve 30 are associated with the second heat exchanger 22. The bypass valves 24, 28 act as check valves to permit flow in only one direction.

[0017] In operation, with the flow reversing device 14 actuated to a cooling configuration, the refrigerant flows to the first heat exchanger 20 where heat is rejected to the first location 21. Refrigerant then flow through the bypass valve 24 and is expanded through thermal expansion device 30. The refrigerant is vaporized and then enters the second heat exchanger 22 where the second location 23 rejects heat to the refrigerant before being returned to the centrifugal compressor 12. With the flow reversing device 14 actuated to a heating configuration, the refrigerant flows to the second heat exchanger 22 where heat is rejected to the second location 23. Refrigerant then flow through the bypass valve 28 and is expanded through thermal expansion device 26. The refrigerant is vaporized and then enters the first heat exchanger 20 where the first location 21 rejects heat to the refrigerant before being returned to the centrifugal compressor 12. The heat pump system 10 is intended to be exemplary only.

[0018] Referring to Figure 2, the centrifugal compressor 12 includes a housing 39 within which an electric motor 38 is arranged. The housing 38 is schematically depicted and may comprise one or more pieces. The electric motor 38 rotationally drives first and second

impellers 42, 44 via a rotor shaft 40 about an axis to compress the refrigerant in a two-stage compressor configuration. The rotor shaft 40 may comprise one or more pieces. Although two compressor stages are shown, the disclosure may also be used in a compressor having more stages. In the example shown, the first and second impellers 42, 44 are located on opposing ends of the rotor shaft 40. The impellers are centrifugal such that the impeller inlet is arranged axially and the impeller outlet is arranged radially.

[0019] An oil-free bearing arrangement is provided for support of the rotor shaft 40 so that oil-free refrigerant can be used in the centrifugal compressor 12. In the example, the rotor shaft 40 is rotationally supported relative to the housing 39 by magnetic bearings 46, which are illustrated in a schematic fashion. The magnetic bearings 46 may include radial and/or axial magnetic bearing elements, for example. A bearing controller (not shown) communicates with the magnetic bearing 46 providing a magnetic bearing command to energize the magnetic bearings 46. The magnetic bearings create a magnetic field levitating the rotor shaft 40 and controls its characteristics during operation of the centrifugal compressor 12. It should be understood that the disclosed diffuser arrangements may also be used with air bearings or other types of bearings.

[0020] One example electric motor 38 includes a rotor supporting multiple magnets about its circumference. A stator is arranged about the rotor to impart rotational drive to the rotor shaft 40 when energized. In one example, a motor controller (not shown) communicates with the stator and provides a variable speed command to rotationally drive the impellers 43, 44 at a variable speed depending upon compressor operating conditions. The motor controller communicates with multiple sensors (not shown) to monitor and maintain the compressor operating conditions.

[0021] The first and second impellers 42, 44 are arranged in series relative to one another and providing a desired compressor pressure ratio, which in one example is at least 10:1. The first impeller 42 includes a first stage inlet 48 and a first stage outlet 52, and the second impeller 44 includes a second stage inlet 54 and a second stage outlet 58. First and second stage volutes 50, 56 are arranged respective at the first and second stage outlets 52, 58. The desired

compressor pressure ratio corresponds to a second stage outlet pressure to a first stage inlet pressure.

[0022] First and second diffusers 60, 62 are respectively arranged at the first and second stage outlets 52, 58 near the first and second stage volutes 50, 56. In one example, the first and second diffusers 60, 62 are variable geometry diffusers, which may be any suitable type. First and second actuators 64, 66 are configured to respectively move the first and second variable geometry diffusers between first and second positions. Referring to Figure 4, the second compressor stage is shown as an example. A passage 70 is arranged downstream from the second impeller 44. A variable geometry device, such as a movable wall 72, for example is arranged in the passage in the second stage outlet 58. The second actuator 62 moves the wall 72 between a first position F and a second position S to selectively regulate refrigerant flow through the passage 70.

[0023] Any number of variable geometry diffuser arrangements may be used. For example, a movable-wall variable-geometry diffuser includes a plurality of fixed wedge shaped vanes located downstream of the movable diffuser wall element. The movable wall element may be serrated with the trailing edge of the serration coinciding with the throat area (which is the smallest cross-sectional flow passage) of the vaned diffuser.

[0024] In another variable geometry diffuser example, a rotatable vane diffuser in the plane normal to the compressor axis. By rotating the vanes, the throat area of the diffuser changes, and, therefore, the capacity of the compressor, is adjusted.

[0025] In another variable geometry diffuser example, a split vaned diffuser has an outer diffuser ring and an inner diffuser ring. Throat area adjustment is obtained by rotating one diffuser ring with respect to the other one. Throat area of the fully opened diffuser is reduced as a result of the rotation of the inner diffuser ring relative to the outer diffuser ring.

[0026] An economizer 68 may be mounted to the housing 39, as shown in Figure 3. In one example, the economizer 68 is a heat exchanger-type economizer. The economizer 68 is arranged fluidly between the first stage outlet 52 and the second stage inlet 54.

[0027] Although two compressor stages are shown in Figure 2, the disclosure may also be used in a compressor having more stages. For the shown direct-drive gearless multistage

compressors the impellers are arranged on opposing ends of the rotor shaft (the so-called back-to-back configuration) reducing the axial thrust load of the shaft. In one example three-stage configuration, only the first compressor stage includes a variable geometry diffuser, and the second and third stages may each include a volute without a diffuser and still achieve the desired compressor pressure ratio.

[0028] Although example embodiments have been disclosed, a worker of ordinary skill in this art would recognize that certain modifications would come within the scope of the claims. For that reason, the following claims should be studied to determine their true scope and content.

CLAIMS

What is claimed is:

1. A heat pump system including:
a refrigerant circuit;
first and second heat exchangers arranged in the refrigerant circuit;
a flow reversing device selectively changing a direction of flow in the refrigerant circuit between the first and second heat exchangers; and
a centrifugal compressor arranged in the fluid circuit and having first and second impellers arranged in series relative to one another and providing a desired compressor pressure ratio;
wherein the first and second impellers respectively include first and second stage inlets and outlets, and the desired compressor pressure ratio corresponds to a second stage outlet pressure to a first stage inlet pressure;
wherein the compressor includes first and second diffusers respectively arranged at the first and second stage outlets; and
wherein the first and second diffusers are variable geometry diffusers, and the compressor includes first and second actuators configured to respectively move the first and second variable geometry diffusers between first and second positions.
2. The heat pump system according to claim 1, wherein the desired compressor pressure ratio is about 10:1.
3. The heat pump system according to claim 1, including an economizer arranged fluidly between the first stage outlet and the second stage inlet.
4. The heat pump system according to claim 1, wherein the compressor includes a variable speed motor configured to rotationally drive the first and second impellers.

5. The heat pump system according to claim 1, wherein compressor includes a shaft supporting the first and second impellers, and magnetic bearings support the shaft.

6. A refrigerant centrifugal compressor including:

first and second impellers mounted on opposing ends of a shaft, the first and second impellers respectively include first and second stage inlets and outlets, and a desired compressor pressure ratio of at least 10:1 corresponding to a second stage outlet pressure to a first stage inlet pressure; and

a first diffuser arranged at the first stage outlet, wherein the first diffuser is a variable geometry diffuser;

a second diffuser arranged at the second stage outlet;

wherein the second diffuser is a variable geometry diffuser; and

first and second actuators configured to respectively move the first and second variable geometry diffusers between first and second positions.

7. The refrigerant centrifugal compressor according to claim 6, including an economizer mounted on the compressor and arranged fluidly between the first stage outlet and the second stage inlet.

8. The refrigerant centrifugal compressor according to claim 6, including a variable speed motor configured to rotationally drive the first and second impellers.

9. The refrigerant centrifugal compressor according to claim 6, including magnetic bearings supporting the shaft.

1/1

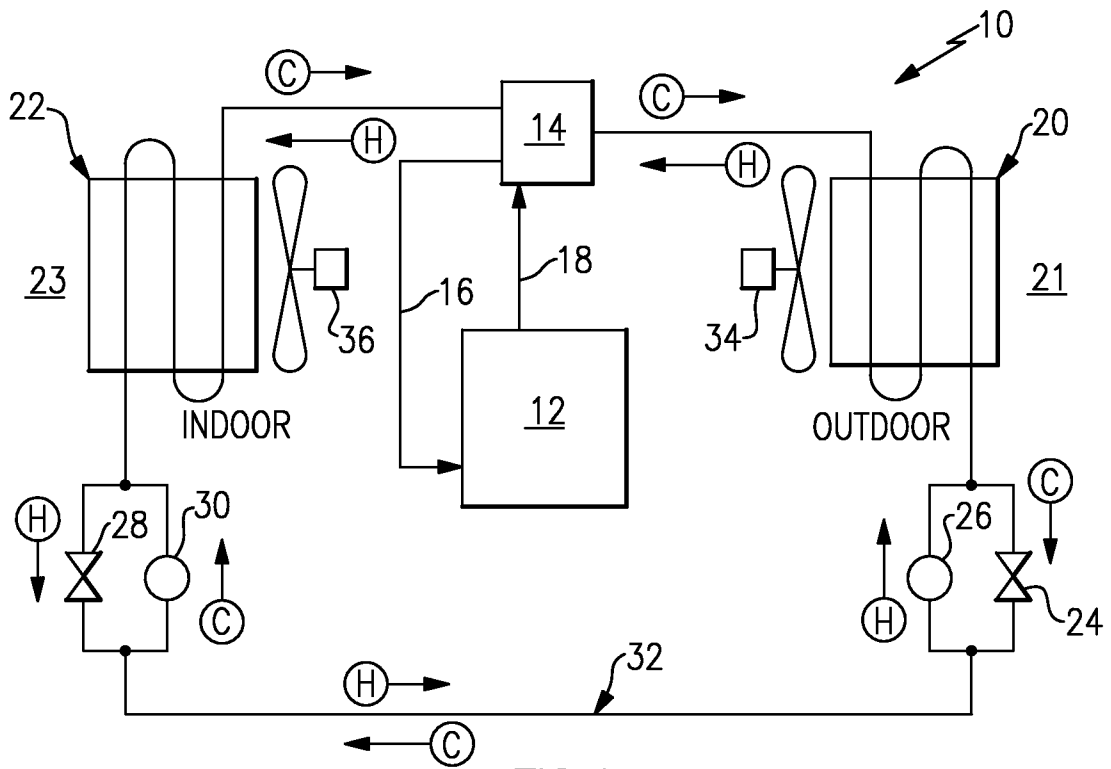

FIG. 1

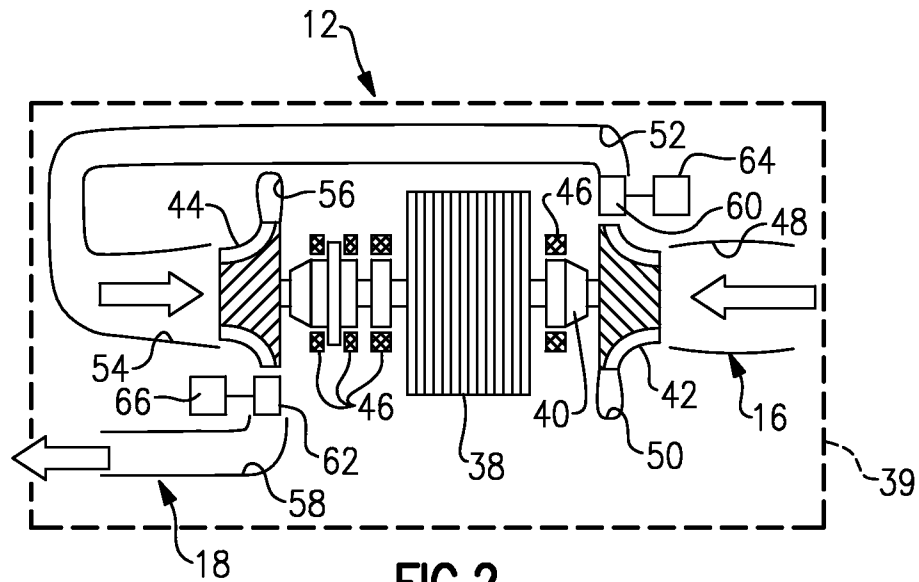

FIG. 2

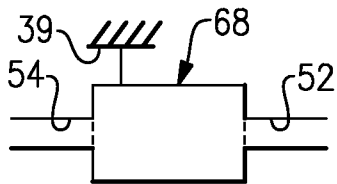

FIG. 3

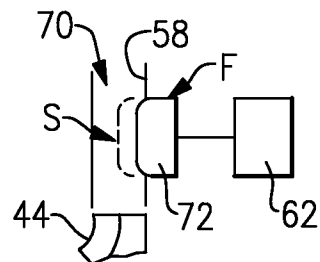

FIG. 4