

May 9, 1933.

D. J. O'GRADY

1,908,174

DRILL STRING COUPLING

Filed Oct. 20, 1931

2 Sheets-Sheet 1

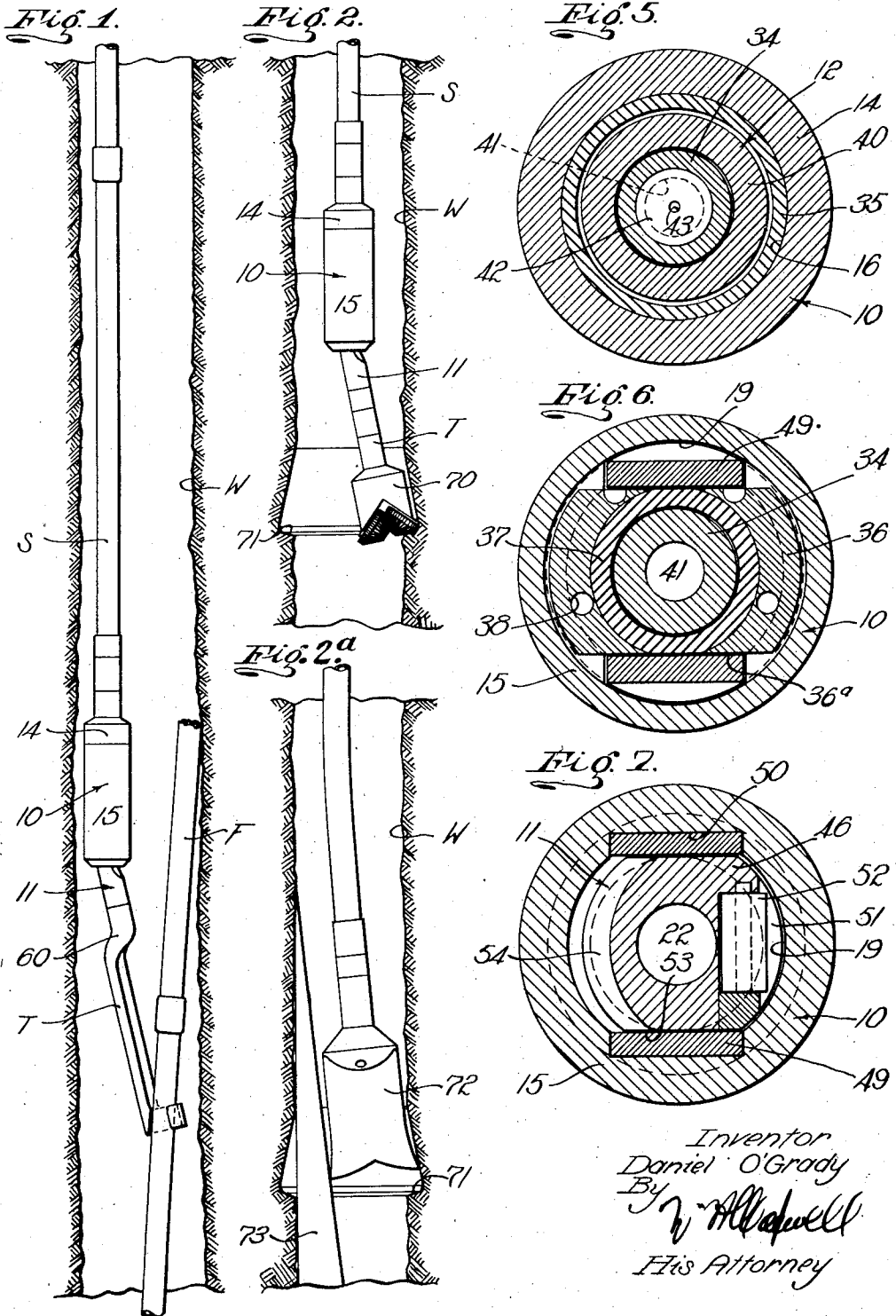

Inventor
Daniel O'Grady
By *W. H. Allredwell*
His Attorney

May 9, 1933.

D. J. O'GRADY

1,908,174

DRILL STRING COUPLING

Filed Oct. 20, 1931

2 Sheets-Sheet 2

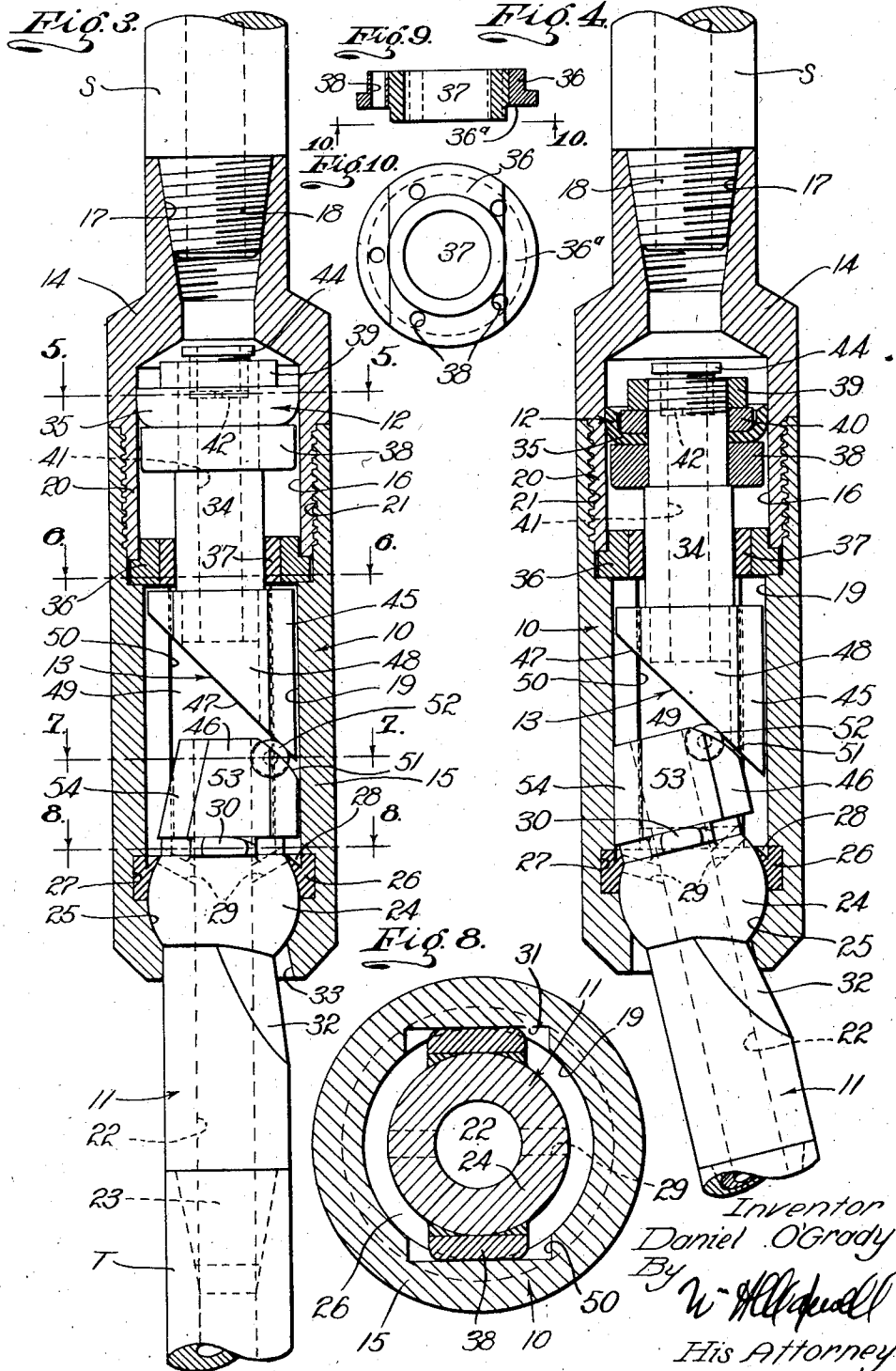

UNITED STATES PATENT OFFICE

DANIEL J. O'GRADY, OF LONG BEACH, CALIFORNIA

DRILL STRING COUPLING

Application filed October 20, 1931. Serial No. 569,900.

This invention relates to a well tool and relates more particularly to a device for use in fishing operations, the side-tracking of drilling tools and other well drilling operations.

A general object of the invention is to provide a simple, practical and effective tool carrying device adapted to be attached to the lower end of a string of drill pipe, or the like, and that is operable to move the tool which it carries out of vertical or longitudinal alignment with the operating string and to hold it in that position.

Considerable difficulty is sometimes encountered in fishing or removing a lost part from a well, due to the fact that the fish is against the wall of the well bore, or is in a position where the fishing tool attached to the operating string in the usual manner cannot be brought into proper engagement with it. It is the usual practice to rigidly attach a fishing tool to the lower end of the operating string in vertical or longitudinal alignment with the string. When the lost part or fish is lying against the side wall of the well bore or is out of alignment with the operating string, it becomes very difficult to bring the fishing tool into gripping and holding engagement with the fish.

In certain well drilling operations, it is desirable to make an enlargement or to provide an upwardly facing shoulder in the well bore. When side-tracking a drilling tool for example, it may be necessary to cut a shoulder or enlargement in the walls of the well bore to cause the drilling tool to readily cut laterally into the formation when deflected by the whip stock.

An object of the present invention is to provide a device for attaching or connecting a fishing tool, a drilling tool, or the like, to the lower end of an operating string, that is operable to move the tool to an off-set and inclined position with respect to the operating string and to hold the tool in the off-set and inclined position during the operation of the tool.

Another object of the invention is to provide a device of the character mentioned that is operated hydraulically, that is, it is oper-

ated or controlled by varying the pressure on the circulation fluid in the operating string. The tool provided by this invention may be passed into the well on the lower end of an operating string in the normal or un-actuated position where it carries a tool in longitudinal alignment with the string, and may be operated when in any desired position in the well to move the tool to the off-set and inclined position by putting pressure or increased pressure on the circulation fluid in the operating string.

Another object of the invention is to provide a tool carrying a device of the character mentioned that is positive in operation and that is simple and sturdy in construction. The device provided by the present invention does not embody any springs, hinge pins, screws, or the like, that might be subject to failure, or to become made inoperative by the presence of mud or solid matter in the device.

Another object of the invention is to provide a device of the character mentioned that permits the continuous circulation of fluid through the operating string and tool. After actuation of the device, a full or ample circulation of fluid may be maintained through the operating string of drill pipe and the device.

Another object of the invention is to provide a tool carrying device of the character mentioned that is operable to transmit a turning or rotary motion from the operating string to the tool. The device is constructed so that the tool may be turned to any desired position in the well bore or may be rotated if desired.

Another object of the invention is to provide a device of the character mentioned in which the tiltable connection between the body of the device and the tool carrying element is protected by an improved packing means that prevents sediment or solid matter from reaching the working parts of the connection, and prevents the leakage of circulation of fluid from the connection.

Further objects and features of the invention will be best and more fully understood from the following detailed description of a

typical form and application of the invention, throughout which description reference will be had to the accompanying drawings, in which:

5 Fig. 1 illustrates the device provided by this invention mounted on the lower end of an operating string in a well bore and carrying a fishing tool in engagement with a fish. Fig. 2 shows the invention carried on the
10 lower end of an operating string and operating a well drilling tool. Fig. 2a illustrates a well drilling tool being deflected by a whipstock into the cut made by the tool illustrated in Fig. 2 of the drawings. Fig. 3 is an enlarged longitudinal detailed sectional view of the device showing the parts in the normal or unactuated positions. Fig. 4 is a view similar to Fig. 3 showing the parts in the actuated positions. Figs. 5, 6, 7 and 8 are enlarged transverse detailed sectional views taken as indicated by lines 5—5, 6—6, 7—7 and 8—8 respectively, on Fig. 3. Fig. 9 is a vertical sectional view of the bearing included in the present invention, and Fig. 10
25 is a bottom elevation of the bearing, being a view taken as indicated by lines 10—10 on Fig. 9.

The tool or device provided by my invention can be used in numerous situations and in connection with various well drilling operations, for example, it may be employed in fishing operations, in the side-tracking of a drill tool from a well bore, and may carry a wall hook, a socket, a grab, a tap, a drill collar, or any other form of fishing tool, as well as drilling tools of various characters, casing cutters, etc. Throughout the following detailed disclosure, a single typical embodiment and two uses or applications of the invention
40 will be described. It is to be understood, however, that the invention is not to be taken as limited or restricted to the specific form or applications about to be described, but is to be taken as including any features or modifications that may fall within the scope of the claims.

The device of the present invention includes, generally, a body 10 adapted to be attached to the lower end of an operating string S of drill pipe, a stem 11 for carrying a tool T and projecting from and tiltably connected with the body 10, a piston 12 operable in the body by fluid pressure, and an operative connection 13 between the piston 12 and the tilt-
55 able tool carrying stem 11 whereby operation of the piston 12 tilts or operates the stem.

The body 10 is a tubular structure carrying and encasing the piston 12 and the other principal parts of the device. The body 10 is preferably sectional, comprising an upper section 14 and a lower section 15. The upper section 14 of the body is tubular, having a central longitudinal opening 16 and is provided at its upper end with suitable means
60 for connection with the operating string S.

In the particular case illustrated in the drawings, a tapered screw-threaded socket 17 is provided in the upper end of the section 14 to receive the pin 18 of a tool joint section, or the like, on the lower end of the operating string S. The main or lower end portion of the opening 16 is of enlarged diameter and slidably carries the piston 12 as will be subsequently described. The lower section 15 of the body 10 is tubular, having a central longitudinal opening 19 extending through it from one end to the other. The section 15 may be of the same external diameter as the lower end part of the section 14 and the opening 19 may be of substantially the same diameter as the opening 16. A suitable screw-threaded connection is provided between the sections 14 and 15. In the specific form of the invention illustrated in the drawings, a threaded pin 20 is provided on the lower end of the upper section 14 to thread into a socket 21 in the upper end of the section 15.

The stem 11 is an elongated member having a central longitudinal fluid passage 22. The upper end of the stem 11 extends into the lower end of the body section 15, while the lower end of the stem 11 is connected with the tool T. The passage 22 operates to pass fluid from the interior of the body 10 to the tool T. A tapered screw-threaded pin 23, or the like may be provided on the lower end of the stem 11 to facilitate the connection of the stem with the tool T.

A tilting connection is provided between the body 10 and the stem 11 whereby the stem is movable from the normal position illustrated in Fig. 3 of the drawings to the actuated position illustrated in Fig. 4 of the drawings. The tilting or tiltable connection between the stem 11 and the body includes a rounded or spherical enlargement 24 on the stem 11 and a seat 25 in the body 10 for carrying the spherical enlargement 24. The rounded enlargement is integral with the stem 11 and is provided adjacent the upper end of the stem. The seat 25 is provided in the wall of the opening 19 adjacent the lower end of the body and is concave to effectively cooperate with the ball or enlargement 24. The enlargement 24 fits the seat 25 so that the stem 11 is free to tilt or oscillate about an axis transverse of the longitudinal axis of the device.

In accordance with the preferred embodiment of the invention, packing means is provided to prevent sediment or solid matter from getting between the spherical enlargement 24 and the seat 25, and to prevent the leakage of fluid from the connection. An annular body of packing 26 is provided in a groove 27 in the wall of the opening 19 immediately above the seat 25. The packing 26 may be in the nature of rubber or the like, and its inner side is concave and shaped to effectively seal with the ball or enlargement
130

24. The packing 26 is compressed or acted upon by the fluid under pressure in the opening 19 to tightly seal with the enlargement 24 and with the walls of the groove 27. An annular groove 28 is provided in the upper end of the packing 26 to allow the fluid pressure to force the packing against the ball enlargement 24 and against the walls of the groove 27. It is preferred to make the groove 28 of substantially V shaped cross section, as clearly illustrated throughout the drawings. The packing 26 in sealing between the enlargement 24 and the body, prevents solid matter or sediment from interfering with the free movement of the stem 11. Drain openings 29 may be provided in the stem 11 to allow any sediment that may settle in the body to pass into the fluid passage 22.

In the preferred construction, the stem 11 is prevented from rotating relative to the body 10 and is adapted to project from only one side of the body. Lugs or projections 30 are provided at diametrically opposite points on the stem 11. The projections 30 are provided on the stem on the upper end of the spherical enlargement 24, and have flat vertical outer sides. The outer sides of the projections 30 cooperate with flat vertical faces 31 provided on the walls of the opening 19. The cooperation of the projections 30 with the faces 31, holds the stem 11 against rotation relative to the body 10 and permits tilting of the stem about a transverse axis. The stem 11 is chamfered or cut away immediately below the enlargement 24 as at 32. The wall of the body opening 19 immediately below the seat 25 and passing the cutaway portion 32 of the body is flared outwardly and downwardly as illustrated at 33. The cutaway portions 32 and 33 permit the stem to tilt outwardly and upwardly to the position illustrated in Fig. 4 of the drawings.

The piston 12 is slidable in the opening 15 of the upper body section 14 and is operable downwardly by fluid under pressure to cause the actuation or tilting of the stem 11. The piston 12 includes a mandrel or rod 34 and a sealing member or cup-leather 35 for sealing with the walls of the opening 16. The rod 34 is guided for central vertical movement by the bearing 36. The bearing 36 may be removably clamped between the lower end of the pin 20 and the bottom of the socket 21. A suitable bushing 37 may be provided in the bearing 36 to slidably pass and guide the rod 34. Spaced vertical openings 38 are provided in the bearing 36 to put the opening 16 in communication with the opening 19 so that back pressure cannot develop below the piston 12. The cup-leather 35 is mounted on the rod 34 between a block 38 and a nut 39 screw-threaded on the upper end of the rod. A suitable washer 40 may be provided between the nut 39 and the cup-leather 35. The cup-leather 35 is such that pressure on the

fluid above the piston is effective in operating the piston downwardly.

In accordance with the invention, the piston rod 34 is tubular, having a central longitudinal fluid passage 41 extending through it from one end to the other. An orifice plate 42 is arranged across the passage 41 and has a comparatively small orifice or opening 43. The orifice plate 42 may be removably retained in position by a tubular nut threaded into the upper end of the passage 41. The orifice plate 42 provides for a differential in pressure above and below the piston. The orifice plate 42 in restricting the fluid passage 41, allows pressure to build up on the fluid in the operating string S so that the piston 12 is operable downwardly when pressure is put on the circulation fluid in the string. It is preferred to form the orifice plate 42 of cast iron or other friable or frangible material so that it may be broken out if desired. The orifice plate 42 may be broken out in various manners, for example, an object such as a steel ball or the like may be passed into the operating string S to close the orifice 43, and high pressure may be put on the fluid in the operating string to break out the plate.

The operative connection 13 between the piston 12 and the stem 11 is in the nature of a wedge or cam means operable to cause tilting of the stem 11 upon downward movement of the piston 12. The operative connection 13 includes a wedge or cam part 45 on the lower end of the rod 34 and a head 46 on the upper end of the stem 11. The cam part 45 is in the nature of an enlargement on the piston rod 34 below the bearing 36. An inclined wedge or cam face 47 is provided on the lower end of the cam part 45. The face 47 may be flat and may occupy the entire lower end of the cam part 45. Flat vertical faces 48 are provided at diametrically opposite sides of the cam part 45. The faces 48 slidably cooperate with vertical plates 49 to hold the cam part 45 and the piston 12 against turning or rotating in the body. The plates 49 are comparatively long and are seated in vertical keyways or grooves 50 in the walls of the body opening 19. The faces 31 are the inner walls of the grooves 50. The plates also operate to hold the stem against upward movement. The inner ends of the plates extend into notches 36^a in the bearing 36 while the lower ends of the plates engage the upper ends of the lugs 30. The upper ends of the lugs 30 are flat to effectively cooperate with the ends of the plates 49. The upper corners of the lugs 30 are beveled or rounded to allow the stem to rotate.

The head 46 may be in the nature of an integral projection on the upper end of the stem 11 above the spherical enlargement 24. The upper corner 51 of the head 46 opposing

the cam face 47 is beveled or inclined downwardly and outwardly. An anti-friction roller 52 is rotatably mounted on the head 46 to project from the beveled corner 51.

5 The cam face 37 is adapted to cooperate with the anti-friction roller 52 upon operation of the piston 12. Flat vertical faces 53 may be provided at diametrically opposite sides of the head 46 to slidably engage the plates

10 49 to assist the projections 30 in holding the stem 11 against rotation relative to the body 10. The axis of the tilting movement of the stem 11 is transverse of the faces 53 and the plates 49.

15 The outer side of the head 46 is sloped or inclined upwardly and inwardly and is of the same curvature as the walls of the opening 19, so that it permits the desired tilting of the stem and so that it engages the walls

20 of the opening 19 to limit the tilting movement of the stem.

In employing the device provided by this invention, the body 10 may be attached to the lower end of the operating string S in

25 the manner illustrated throughout the drawings, and the well tool T may be attached to the lower end of the tiltable stem 11. The device and the tool T may be passed into the well with the parts in the positions illustrated in Fig. 3 of the drawings. When the

30 tool T is in the desired position in the well bore, pressure or increased pressure is applied to the fluid in the operating string S to cause the downward movement of the piston 12. It will be apparent how the orifice

35 plate 42, in restricting the fluid passage 41, provides a differential in pressure at opposite sides of the piston so that pressure on fluid above the piston causes the downward

40 operation of the piston. Downward movement of the piston 12 causes the cam face 47 to cooperate with the roller 52 to move or tilt the stem 11 from the normal vertical position to the tilted position illustrated in Fig.

45 4 of the drawings. It is to be noted that the point of contact between the roller 52 and the cam face 47 is spaced from the axis of movement of the stem 11 so that the necessary leverage is obtained to swing or tilt the

50 lower projecting end of the stem outwardly. After the stem has been operated to the inclined or off-set position in the manner described above, the operating string may be

55 manipulated as desired or found necessary, to carry out the operations with the tool T. It is to be noted that when the stem 11 is in the inclined or off-set position illustrated in

60 Fig. 4 of the drawings, that the projections 30 and the faces 31 cooperate with parts on the body 10 to positively hold the stem 11 against turning with respect to the body. Due to this construction, the operating string S may be rotated or turned if desired to rotate the tool T. Pressure may be maintained

65 on the fluid in the operating string during

the manipulation or operation of the tool T so that the stem 11 is tightly held in its inclined position and has no tendency to shift or move relative to the body 10. The face

70 54 of the stem forms an effective abutment for cooperating with the interior of the body and positively limits the tilting movement of the stem. If after operation of the device it is desired to maintain or provide full

75 circulation of fluid through the device, the orifice plate 42 may be fractured or broken out. A steel ball or other suitable object may be dropped into the operating string S to come to rest on the orifice plate and close

80 the opening 43. Heavy or increased pressure may then be put on the fluid in the operating string to fracture the friable disc 42. The device provided by the present invention may be employed in various situa-

85 tions, and may be used to carry various types of well tools. In Figs. 1 to 2a inclusive of the drawings, I have illustrated two typical uses or applications of the invention.

In Fig. 1 of the drawings, the device provided by my invention is shown mounted on the lower end of an operating string S of

90 drill pipe. A fishing tool in the form of a wall hook 60 is attached to the lower end of the tiltable stem 11. A fish F in the form of a broken off portion of a string of pipe is

95 illustrated resting in an inclined position against the wall of the well bore W. The operating string S carrying the device, and the fishing tool 60 may be passed down-

100 wardly into the well bore with the parts of the device in the normal or unactuated positions. After the string is lowered to a point where the fishing tool or wall hook 60 is adjacent the fish F, pressure is put on the fluid

105 in the operating string to operate the piston 12 downwardly and cause tilting of the stem 11. Tilting of the stem 11 throws or moves the fishing tool 60 to the inclined position

110 illustrated in the drawings. After actuation of the device, the string S is manipulated or operated to bring the fishing tool 60 into gripping or holding engagement with the fish F. It will be apparent how the fish-

115 ing tool 60 being in an inclined or off-set position in relation to the fishing string S is capable of engaging a lost object that is lying against the wall of the well which would be inaccessible to a fishing tool carried and operated in the usual manner. After the fish

120 F is gripped by the fishing tool 60, the operating string S may be withdrawn from the well bore to remove the fish F.

In Fig. 2 of the drawings I have illustrated a roller type of drilling tool 70 attached to the lower end of the stem 11. The tool of the

125 present invention is attached to the lower end of an operating string S in the manner described above. The device is illustrated in the actuated position where the stem 11 is tilted and where it carries the drilling tool

130

70 in an off-set and inclined position. The drilling tool 70 is shown cutting an enlargement or shoulder 71 in the walls of the well bore W. It will be apparent how the drilling tool 70 carried on the lower end of the inclined stem 11, cuts outwardly or laterally into the walls of the well bore W. Fig. 2a of the drawings illustrates a drilling tool 72 being deflected by a whip-stock 73. The whip-stock 73 deflects the drilling tool 70 to extend into the enlargement made by the tool 70 and to cut into the formation at the shoulder 71. The provision of the shoulder 71 in the well bore facilitates the side-tracking of the drilling tool 72 to cut laterally into the formation at the side of the well bore W.

The application or uses of the present invention illustrated in Figs. 1, 2 and 2a of the drawings are to be taken as merely typical examples of the uses of the invention and are not to be taken as restricting or confining its range of utility or use.

Having described only a typical preferred form of my invention, I do not wish to limit myself to the specific details set forth, but wish to reserve to myself any changes or variations that may appear to those skilled in the art or fall within the scope of the following claims.

Having described my invention, I claim:

1. A device of the character described for use on a string of pipe including a tubular body to be attached to the lower end of the string and adapted to communicate with the string, a stem projecting from the lower end of the body and tiltably connected to the body, means on the stem for carrying a tool, there being a fluid passage in the stem for passing fluid from the body to the tool, fluid pressure actuated means in the body, and an operative connection between the said means and the stem whereby said means is operable to tilt the stem.
2. A device of the character described for use on a string of pipe including a tubular body to be attached to the lower end of the string, a stem for carrying a tool and projecting from the lower end of the body and tiltably connected to the body, there being a passage in the stem for circulating fluid from the body to the tool, and fluid pressure actuated means for tilting the stem.
3. A device for use on a string of drill pipe including, a tubular body to be mounted on the string, a tool carrying stem projecting from the lower end of the body, a ball and socket connection between the stem and the body whereby the stem is tiltably, there being a fluid passage through the said connection and the stem, and fluid pressure actuated means for tilting the stem.
4. A device for use on a string of drill pipe including, a body to be mounted on the string, a tool carrying stem projecting from the lower end of the body, means tiltably connecting the stem with the body, including a seat in the body, and a spherical part on the stem cooperating with the seat, and fluid pressure actuated means in the body for tilting the stem.
5. A device for use on a string of drill pipe including, a body to be mounted on the string, a tool carrying stem projecting from the lower end of the body, means tiltably connecting the stem with the body including a seat in the body, a spherical part on the stem cooperating with the seat, and packing means for sealing with said part above the seat, and fluid pressure actuated means for tilting the stem.
6. A device for use on a string of drill pipe including, a body to be mounted on the string, a tool carrying stem projecting from the lower end of the body, means tiltably connecting the stem with the body including a seat in the body, a spherical part on the stem cooperating with the seat, and means for holding the stem against rotation relative to the body, and means for tilting the stem.
7. A device for use on a string of drill pipe, including a tubular body attached to and having its interior in communication with the string, a tool carrying stem projecting from the lower end, a connection between the stem and the body whereby the stem is tiltably, there being a fluid passage through the connection and the stem and means for tilting the stem including, a tubular piston in the body operable by fluid under pressure in the string, and an operative connection between the piston and stem.
8. A device for use on a string of drill pipe, including a tubular body attached to and having its interior in communication with the string, a tool carrying stem tiltably connected with the body and projecting from the lower end thereof, and means for tilting the stem including, a piston on the body operable by fluid under pressure in the string, there being a longitudinal fluid passage in the piston, an orifice plate in the said fluid passage, and an operative connection between the piston and stem.
9. A device for use on a string of drill pipe, including a tubular body attached to and having its interior in communication with the string, a tool carrying stem tiltably connected with the body and projecting from the lower end thereof, and means for tilting the stem including, a piston on the body operable by fluid under pressure in the string, there being a longitudinal fluid passage in the piston, a frangible orifice plate restricting said passage, and means operatively connecting the piston and stem.
10. A device for use on a string of drill pipe, including a tubular body attached to and having its interior in communication

with the string, a tool carrying stem tiltably connected with the body and projecting from the lower end thereof, and means for tilting the stem including, a piston on the body
5 operable by fluid under pressure in the string, there being a longitudinal fluid passage in the piston, an orifice plate in the said fluid passage, and an operative connection between the piston and stem, there being a fluid
10 passage in the stem for passing fluid from the body to the tool.

11. A device for use on a string of drill pipe, including a body to be mounted on the lower end of the string, a stem tiltably connected with the body and projecting from
15 the lower end of the body, a piston operable downwardly in the body, the piston having a longitudinal fluid passage, an orifice plate restricting said passage, and cam means operatively connecting piston and stem where-
20 by operation of the piston tilts the stem, there being a fluid passage in the stem for passing fluid from the body to a tool on the stem.

25 12. A device for use on a string of drill pipe including a tubular body adapted to be connected with the lower end of the string, a stem projecting from the lower end of the body and adapted to carry a tool, means
30 for pivotally connecting the stem to the body including a seat in the body, and a spherical part on the stem cooperating with the seat, means on the body for pivoting the stem, and means for preventing rotation of the stem
35 relative to the body including cooperating flat surfaces on the body and said spherical part.

In witness that I claim the foregoing I have hereunto subscribed my name this 14th
40 day of October 1931.

DANIEL J. O'GRADY.

45

50

55

60

65