



INTERNATIONAL APPLICATION PUBLISHED UNDER THE PATENT COOPERATION TREATY (PCT)

<p>(51) International Patent Classification ⁶ : H01M 10/48, G01R 31/36</p>	<p>A1</p>	<p>(11) International Publication Number: WO 99/05745 (43) International Publication Date: 4 February 1999 (04.02.99)</p>
<p>(21) International Application Number: PCT/US98/18243 (22) International Filing Date: 23 July 1998 (23.07.98) (30) Priority Data: 08/900,037 24 July 1997 (24.07.97) US (71) Applicant: EVEREADY BATTERY COMPANY, INC. [US/US]; 25225 Detroit Road, P.O. Box 450777, Westlake, OH 44145 (US). (72) Inventor: BAILEY, John, C.; 23447 Emmons Road, Columbia Station, OH 44028 (US). (74) Agent: POPHAL, Michael, C.; Eveready Battery Company, Inc., 25225 Detroit Road, P.O. Box 450777, Westlake, OH 44145 (US).</p>	<p>(81) Designated States: AL, AM, AT, AU, AZ, BA, BB, BG, BR, BY, CA, CH, CN, CU, CZ, DE, DK, EE, ES, FI, GB, GE, GH, GM, HR, HU, ID, IL, IS, JP, KE, KG, KP, KR, KZ, LC, LK, LR, LS, LT, LU, LV, MD, MG, MK, MN, MW, MX, NO, NZ, PL, PT, RO, RU, SD, SE, SG, SI, SK, SL, TJ, TM, TR, TT, UA, UG, UZ, VN, YU, ZW, ARIPO patent (GH, GM, KE, LS, MW, SD, SZ, UG, ZW), Eurasian patent (AM, AZ, BY, KG, KZ, MD, RU, TJ, TM), European patent (AT, BE, CH, CY, DE, DK, ES, FI, FR, GB, GR, IE, IT, LU, MC, NL, PT, SE), OAPI patent (BF, BJ, CF, CG, CI, CM, GA, GN, GW, ML, MR, NE, SN, TD, TG).</p> <p>Published <i>With international search report. Before the expiration of the time limit for amending the claims and to be republished in the event of the receipt of amendments.</i></p>	

(54) Title: BATTERY TESTER HAVING PRINTED ELECTRONIC COMPONENTS

(57) Abstract

A battery tester circuit in one aspect of the present invention comprises a display circuit for a battery comprising a display component for displaying information pertaining to the battery, and a display driver component for receiving power from the battery to drive the display component, wherein at least one of the components is printed on a substrate. In another aspect, a battery label comprises a label substrate for covering an outer portion of a battery, and an electric field-responsive liquid crystal display printed on an outer surface of the label substrate for displaying information pertaining to the battery. Preferably, the display driver component comprises a battery discharge level sensing circuit that continuously senses the discharge level and the display continuously displays the discharge level. The display is preferably an electric field-responsive liquid crystal display comprising either polymer liquid crystal or polymer-dispersed liquid crystal material. The display may be formed of one or more layers of active liquid crystal material. The display driver component is preferably an oscillator circuit that may also be printed on the substrate.

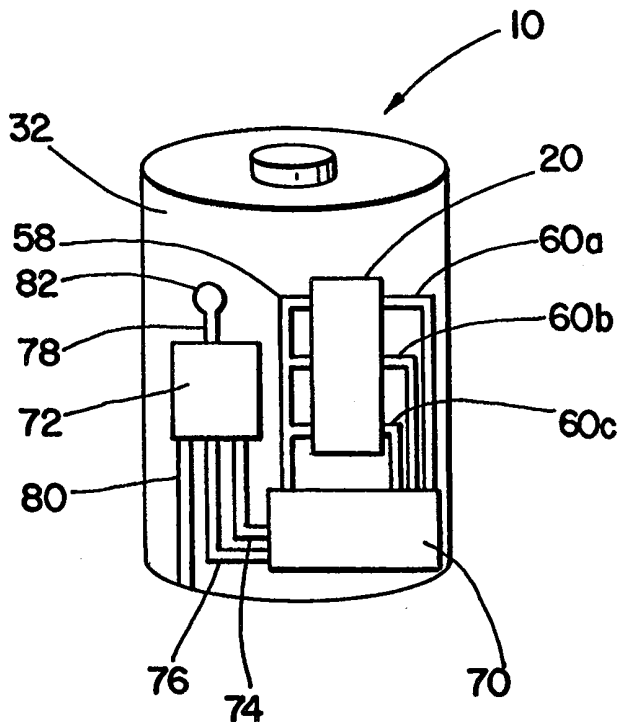

FOR THE PURPOSES OF INFORMATION ONLY

Codes used to identify States party to the PCT on the front pages of pamphlets publishing international applications under the PCT.

AL	Albania	ES	Spain	LS	Lesotho	SI	Slovenia
AM	Armenia	FI	Finland	LT	Lithuania	SK	Slovakia
AT	Austria	FR	France	LU	Luxembourg	SN	Senegal
AU	Australia	GA	Gabon	LV	Latvia	SZ	Swaziland
AZ	Azerbaijan	GB	United Kingdom	MC	Monaco	TD	Chad
BA	Bosnia and Herzegovina	GE	Georgia	MD	Republic of Moldova	TG	Togo
BB	Barbados	GH	Ghana	MG	Madagascar	TJ	Tajikistan
BE	Belgium	GN	Guinea	MK	The former Yugoslav Republic of Macedonia	TM	Turkmenistan
BF	Burkina Faso	GR	Greece	ML	Mali	TR	Turkey
BG	Bulgaria	HU	Hungary	MN	Mongolia	TT	Trinidad and Tobago
BJ	Benin	IE	Ireland	MR	Mauritania	UA	Ukraine
BR	Brazil	IL	Israel	MX	Mexico	UG	Uganda
BY	Belarus	IS	Iceland	MW	Malawi	US	United States of America
CA	Canada	IT	Italy	NE	Niger	UZ	Uzbekistan
CF	Central African Republic	JP	Japan	NL	Netherlands	VN	Viet Nam
CG	Congo	KE	Kenya	NO	Norway	YU	Yugoslavia
CH	Switzerland	KG	Kyrgyzstan	NZ	New Zealand	ZW	Zimbabwe
CI	Côte d'Ivoire	KP	Democratic People's Republic of Korea	PL	Poland		
CM	Cameroon	KR	Republic of Korea	PT	Portugal		
CN	China	KZ	Kazakistan	RO	Romania		
CU	Cuba	LC	Saint Lucia	RU	Russian Federation		
CZ	Czech Republic	LI	Liechtenstein	SD	Sudan		
DE	Germany	LK	Sri Lanka	SE	Sweden		
DK	Denmark	LR	Liberia	SG	Singapore		
EE	Estonia						

BATTERY TESTER HAVING PRINTED ELECTRONIC COMPONENTS

The present invention generally relates to circuits for displaying information relating to batteries, particularly for battery tester circuits, and to battery labels that incorporate such circuits.

Battery tester circuits exist that may be printed on a battery label. Such battery tester circuits are typically either "thermochromic" testers or "electrochromic" testers. Thermochromic testers include a calibrated resistor that may be selectively coupled to the opposite poles of the battery through a switch that is provided at either or both ends of the calibrated resistor. A layer of thermochromic ink is printed over the resistor and responds to changes in the temperature of the calibrated resistor by gradually changing between transparent and opaque states, thereby enabling indicia printed under the thermochromic layer to be viewed or blocked, depending on the temperature of the calibrated resistor. Alternatively, the thermochromic layer may change colour in response to changes in the temperature of the calibrated resistor.

The temperature of the calibrated resistor is determined by the power which the battery can deliver, which is a function of both the voltage and the internal resistance of the battery. The accuracy of a thermochromic tester is determined not only by the rate of change of the open circuit voltage and internal resistance, representing the rate of change of the battery's ability to produce power, but also by the responsivity of the thermochromic ink to temperature changes, *i.e.* the size of the temperature change required to cause the thermochromic ink to change colour. Thus, the thermochromic ink layer functions both as a display and as a sensor, and the accuracy of the tester can be limited by the temperature responsivity of the thermochromic ink.

Electrochromic testers differ from thermochromic testers in that the display layer changes colour directly in response to changes in the open circuit voltage of the battery. The accuracy of an electrochromic tester is determined by the rate of change of the open circuit voltage of the battery with depth of discharge, and by the responsivity of the electrochromic material to voltage changes. Thus, like the thermochromic tester, the electrochromic tester display functions both as a display and as a sensor, and the accuracy of the tester may be limited by the responsivity of the electrochromic material.

Since the accuracy of these thermochromic and electrochromic testers is limited by the response of the display, it has been proposed to improve tester accuracy by including a voltage-responsive electronic component, such as a Zener diode or transistor, and thus to limit the function of the display to displaying information. Such an approach is disclosed in US-A-5,610,511, US-A-5,460,902, and US-A-5,389,470. In these patents, tester circuits are disclosed that utilise discrete electronic components to discriminate between various discharge levels and to selectively activate different segments of a thermochromic display. Thus, these tester circuits provide discrete displays for the various discharge levels that are discriminated by a separate sensing circuit, thereby limiting the function of the display to that of an actual display.

However, because the testers disclosed in these patents utilise discrete electronic components manufactured using conventional semiconductor technology, the electronic components are not sufficiently small to be included in the label of a battery. Further, because the exterior dimensions of batteries are strictly limited by various national and international standards, such electronic components cannot be provided on the exterior surface of a battery. If such electronic components were to be provided in the interior of a battery, the space occupied by the electronic components would reduce the space available for active battery ingredients, thereby reducing the service life of the battery. For these reasons, the use of a

separate voltage discrimination circuit for an on-label tester has not been commercially implemented.

Another problem associated with thermochromic and electrochromic testers concerns the amount of power consumed by these testers. Because these testers consume relatively significant levels of power, switches are provided to enable selective activation of the testers and thus to avoid a constant drain on the battery. Because of the requirement for such switches, however, the displays do not continuously display the discharge level of the battery.

Although general purpose electric field-responsive liquid crystal displays are known, they are too expensive to be included in a battery label and require activation voltage levels well in excess of the open circuit voltage of most batteries. Further, these liquid crystal displays tend to polarise irreversibly when driven by a direct current (DC) driving signal. For these reasons, electric field-responsive liquid crystal displays have been considered to be unsuitable for use in on-label battery testers.

It would therefore be desirable to provide a tester circuit for displaying information relating to the status of a battery, which is not constrained by the accuracy limitations associated with thermochromic and electrochromic displays and which may be provided on the exterior surface of a battery or form part of a battery label. It would also be desirable to provide a more accurate battery tester circuit on a battery label.

Accordingly, in a first aspect, the present invention provides a battery tester circuit comprising a display component for displaying information relating to the status of a battery and a display driver component for receiving power from the battery to drive the display component, wherein at least one of the components is printed on a substrate.

In a preferred embodiment of this first aspect of the present invention, the display component comprises a display printed on the substrate for displaying an indication of the

level of discharge of a battery, and the display driver component comprises a display driver circuit coupled to the display and to the battery for receiving power from the battery to drive the display and a battery discharge level sensing circuit coupled to the display and to the battery for sensing a discharge level of the battery and for supplying a display signal representing the sensed discharge level to the display, wherein at least one of the circuits is printed on the substrate.

In a second aspect, the present invention provides a battery label comprising a label substrate for covering an outer portion of a battery, and an electric field-responsive liquid crystal display printed on an outer surface of the label substrate for displaying information relating to the status of the battery.

In a third aspect, the present invention provides a battery comprising an electrochemical cell provided in a battery housing and having a positive terminal and a negative terminal, and a battery tester circuit as described above, wherein a label substrate is disposed on an exterior surface of the battery housing, a discharge level sensing circuit is directly coupled to the terminals for continuously sensing a discharge level of the battery, and the display component is a liquid crystal display printed on the label substrate and coupled to the discharge level sensing circuit for continuously displaying an indication of the sensed level of discharge of the battery.

By providing a display driver component to drive the display component, the function of the display component has been specifically restricted to that of displaying information, thus avoiding accuracy limitations associated with known display arrangements in which the display material also acts as a sensor. Moreover, by using a component that is printed, the tester circuit can be made sufficiently compact for applications where space is at a premium, such as in on-label battery tester circuits.

The substrate may be any suitable material that can be used in connection with batteries, and is conveniently selected from a battery label, a battery pack housing, a flashlight housing, battery packaging material, or a housing of any other device in or with which batteries are used. The substrate material is appropriately chosen from any materials that can support or contain printed components, such as plastics or paper materials. In a preferred embodiment, the substrate is a battery label. In this case, the label substrate may for example be a laminated or single-layer structure, and preferably is formed of at least one layer of PVC material.

The display component may be any type of display that can be activated by a suitable display driver so as to selectively present or conceal visible information to a viewer. Preferably, the display component comprises a liquid crystal material that is electrically activatable. More preferably, the display component is an electric field-responsive liquid crystal display.

Although the display component is described herein as being provided primarily for use in connection with a battery tester, it will be appreciated that the display may be provided on a battery label to display other information pertaining to the battery. Such information may include advertisements and/or other information or graphics for attracting a consumer's attention. Since, advantageously, the disclosed display may be continuously left in an 'ON' state, the displayed information may periodically alternate between, for example, a graphics advertisement and the battery discharge level. Further, a switch may be provided in the battery label to initiate manually a change in the information displayed.

As mentioned above, the display component in the display circuit in accordance with the invention is used solely for the purpose of displaying information to the consumer. To this end, a separate display driver component is used to drive the display component, thereby limiting the

function of the display component to that of a display only. The display driver component may be any suitable circuit or device that can be powered by the battery and can activate the display in any manner that does not require the display to function as a sensor for the information to be displayed.

The display driver component preferably provides a discriminating function to classify information relating to the status or condition of the battery into appropriate classifications. Preferably, the display driver component provides a voltage discrimination function. For example, a voltage discriminating circuit may be included as part of or as the display driver component in order to compare the sensed open circuit voltage of the battery to generated reference values to determine whether the remaining cell capacity of the battery is fresh, good, or fully discharged. For example, for a AA alkaline Zn-MnO₂ cell, the open circuit voltage may fall from around 1.55 volts to 1.05 volts. Thus, the voltage discriminating circuit is preferably configured to activate one or all the display segments for cell voltages at or above 1.50 volts, to activate two or all but one display segments at voltages between for example 1.40 and 1.49 volts, and so on, to provide an indication representing a gradual change in cell discharge level.

Details and operation of a suitable voltage discriminating circuit as shown in Figure 5 are described in US Patent No. 4,027,231. Other suitable voltage discriminating circuits are disclosed in US Patent Nos. 5,460,902 and 5,610,511.

The voltage discriminating circuit is preferably formed by printing the various elements and connectors directly onto a label substrate or on a protective layer for the display. Techniques for printing resistors in this manner are known and used in printing thermochromic battery testers. Techniques for printing transistors and diodes using polymers are also generally known and described in an article by Francis Garnier *et al.*, entitled "All-Polymer Field-Effect

Transistor Realized by Printing Techniques" appearing in *Science*, Vol. 265, September 16, 1994; and in an article by A.R. Brown *et al.* entitled "Logic Gates Made From Polymer Transistors and Their Uses in Ring Oscillators", *Science*, Vol. 270, November 10, 1995.

An example of a metal-insulator-semiconductor FET (MISFET) transistor printed using such polymers is shown in cross-section in Figure 6. The MISFET as shown includes an insulating layer that may be formed, for example, of a 1.5 μm thick polyester film polyethylene terephthalate. A gate electrode may be printed on one of the faces of the insulating film, for example as a 10 μm thick layer of a conducting graphite-based polymer ink. The MISFET also includes a device substrate that may be made, for example, of a 10 x 15 mm sized adhesive tape with electrical contact for the gate electrode made from the same conducting polymer ink. The source and drain layers of the MISFET may be formed, for example, using two 1 x 10 mm strips that are 10 μm layer thick, of the same conducting graphite-based polymer ink. Preferably, the source and drain electrodes are deposited through a mask with a 200 μm interelectrode distance. The MISFET further includes an organic semiconducting layer that may be formed, for example, of α , ω -di(hexyl)sexithiophene, deposited between the source and drain layers.

It will be appreciated that other discriminating circuits may be used in the display driver component, instead of or additional to a voltage discriminating circuit, in order to classify other sensed properties relating to the performance status or condition of the battery into classifications. Furthermore, it will be appreciated that if additional display segments are provided in order to display additional indications, the discriminating circuit will preferably classify the sensed information into additional classifications to correspond to the number of display segments.

If an electric field-responsive liquid crystal display is used as the display component, then the display driver component preferably provides an oscillator function in order to drive the display with an alternating current and thus to preclude irreversible polarisation of the display. In this case, the display driver component preferably provides both an oscillator function and a voltage discrimination function.

Because in certain circumstances the voltage required to drive the display component may exceed that of the open circuit voltage of the battery and, as mentioned, because electric field-responsive liquid crystal displays are preferably driven using an alternating current (AC) signal rather than a direct current (DC) signal, a voltage multiplying and/or oscillating circuit may be included in the display driver component for driving the display. The frequency of the AC driving signal generated by the circuit may be selected appropriately, and is preferably less than 10 kHz. The voltage levels of the circuit may also be chosen appropriately, and preferably are in the range of 3 to 50 volts. A suitable oscillating circuit that may be formed using polymer transistors suitable for printing on a substrate is shown in Figure 7, as described by A.R. Brown *et al.* in an article entitled "Logic Gates Made From Polymer Transistors and Their Uses in Ring Oscillators", *Science*, Vol. 270, November 10, 1995. As shown, the ring oscillator includes five inverter gates formed of a plurality of MISFETs. The oscillator circuit shown may have an oscillating frequency in the range of 10-500 Hz. The MISFETs may be printed and configured in the same manner as shown in Figure 6. Examples of capacitive voltage doubler circuits capable of producing an AC signal at double the input voltage are described in Maxim 1989 Integrated Circuits Data Book, pp. 6-119; and in F. Mazda, *Electronic Engineer's Reference Book*, 5th Ed., Butterworths, 1983, Chapters 39 and 42.

The positioning of the various circuits in the display driver component may be selected as appropriate. Thus, the voltage multiplying/oscillating circuit is preferably arranged between

the battery terminals and a voltage discriminating circuit, as for example shown in Figure 3. Alternatively, the positioning of these circuits in the display driver component may be reversed such that the voltage discriminating circuit selectively enables the voltage multiplying/oscillating circuit to deliver an AC driving signal to a selected display segment. However, by arranging a voltage multiplying circuit in the manner shown in Figure 3, the voltage discriminating circuit will be presented with a greater range of voltages, thereby increasing its ability to discriminate between various voltage levels.

Since in accordance with the present invention at least one of the display component and display driver component is printed on a substrate, the advantages in terms of space saving can be realised even when only one of the components is printed. However, preferably both components are printed on the substrate, in order to maximise the space saving advantages.

It will be appreciated that the display driver component may comprise a plurality of circuits or functional modules, for example for implementing voltage discriminating and voltage multiplying/oscillating functions, as mentioned above. One or more of these circuits may be printed on the substrate. Preferably, however, all of the constituent circuits of the display driver component are printed. The circuits are preferably formed by printing processable conductive polymer material layers on the substrate. In this manner, a battery tester circuit in accordance with the present invention may conveniently be printed on a battery label using conventional printing techniques.

As mentioned, the display component preferably is an electric field-responsive liquid crystal display and, as such, includes at least one layer of liquid crystal material that undergoes a change in visual appearance in response to an electric field applied across the layer of liquid

crystal material. The electric field-responsive liquid crystal display may be, for example, birefringent or bipolar.

The display may include a graphics layer to provide indications such as "fresh", "good" and "replace", or any other appropriate indications descriptive or informative of the status or condition of the battery according to the selected battery property being tested. Although any appropriate method may be used to provide the indications, the indications are conveniently printed using conventional printing techniques. Conventional inks can be thus be used to provide high contrast indications visible to the viewer when the display is activated or deactivated.

It will be appreciated that one or a plurality of indications may be provided to present information relating to the status or condition of the battery. If more than one indication is to be made visible or invisible, the display preferably comprises a corresponding number of individually activatable segments. Thus, indications printed in a graphics layer, or otherwise provided, may be selectively concealed or revealed by the selected activation of a corresponding segment the display.

It will be appreciated that with an electric-field responsive liquid crystal display in which indications are provided in a graphics layer, the indications may be concealed either by being blocked by the liquid crystal layer or by disappearing against a non-contrasting background provided or revealed by the liquid crystal layer, according to whether the graphics layer is positioned behind or in front of the liquid crystal layer, when viewed.

It will further be appreciated that the position of graphics layer may be varied behind the liquid material, for example so as to be disposed between the outer surface of the substrate and an electrode, or between an electrode and the liquid crystal material, or on the inner surface of

the substrate, provided that the indications are made visible to the viewer when they are not selectively blocked by liquid crystal material.

Alternatively, the graphics layer may be disposed in front of the liquid crystal material, for example between an electrode and a protective covering layer or between an electrode and the liquid crystal material, so that the liquid crystal material selectively determines the background against which the indications appear. In this case, a liquid crystal layer may for example constitute or expose behind it a non-contrasting background for the indications, so that the indications are concealed until the liquid crystal layer is selectively activated, or alternatively deactivated, whereupon it provides or exposes a contrasting background in order to show up and thus reveal the indications. Thus, the graphics layer may be disposed in front of the liquid crystal layer in any suitable position provided that the indications can selectively be concealed against or brought out in contrast against a background when the liquid crystal layer is activated.

It will further be appreciated that the liquid crystal display may be applied either to the outer surface or to the inner surface of a label substrate. If applied to the inner surface, the liquid crystal display will be viewed through the label substrate. Accordingly, the substrate will preferably be transparent or be provided with a transparent window to allow the indications to be viewed.

Each display segment generally comprises paired electrodes that can generate an electric field between them on application of a potential difference. A separate set of electrodes can be provided for each display segment. Alternatively, one member of each electrode pair may be shared between segments. Such segments may be completely isolated from one another or share a common liquid crystal layer.

In an electric field-responsive liquid crystal display, the electrodes may suitably be formed of any conductive material, for example of a transparent conductive material such as tin-

doped indium oxide (ITO), of a thin transparent metal coating formed by vapour deposition or sputtering, or of printing inks that use transparent conductive particles such as tin-doped indium oxide, antimony-doped tin oxide, fluorine-doped tin oxide, or zinc oxide. Other suitable materials will be apparent to those skilled in the art. Preferably, the electrodes are formed from a much less-expensive solution processable conductive polymer such as dodecylbenzene sulphonic acid doped polyaniline, which may be dissolved in a suitable solvent such as toluene. This material is relatively inexpensive and is particularly well-suited for printing as a layer on a substrate or on an adjacent layer, as is desirable for the mass production of tester displays.

It will be appreciated by those skilled in the art that in a liquid crystal display intended to be viewed from the top, as shown for example in Figure 2A, the bottom electrode may be reflective or opaque, instead of transparent. If the bottom electrode is reflective or opaque, the graphics layer is preferably formed on top of the bottom electrode so that it will be visible through the liquid crystal layer. It will further be appreciated that if a liquid crystal display is intended to be viewed from the bottom, for example through the substrate as shown in Figure 2A, and a graphics layer is formed above the liquid crystal layer, then the top electrode may be reflective or opaque, and the graphics layer will then preferably be formed below the top electrode.

The liquid crystal layer may be formed from any suitable electric-field responsive liquid crystal materials known in the art, but is preferably formed of a polymer liquid crystal (PLC) or polymer-dispersed liquid crystal (PDLC) material that may be printed on an adjacent layer using conventional printing techniques. Suitable PLC materials are disclosed in US-A-5,397,503.

In PDLC materials, the liquid crystal material is isolated either in microcapsules embedded in a solid polymer matrix or in micelles in a polymer matrix. The polymer matrix is preferably chosen so that the polymer and liquid crystal material have equal refractive indices in

the presence of a particular electric field. Thus, in an electric field when the respective indices are the same, the material appears clear. When the electric field is removed or altered, the refractive indices become different, incident light is scattered and the material appears cloudy or black with suitable dye additives. Alternatively, the materials may be so chosen as to appear opaque in a certain electric field and transparent in the absence of an electric field or in a different electric field. Examples of birefringent PDLC displays are disclosed in US-A-5,202,063, US-A-5,285,299 and US-A-5,225,104.

The liquid crystal display preferably includes one or more protective layers made of a transparent material such as PVC. It will be appreciated that the graphics, electrode, liquid crystal and protective layers, as appropriate, may be printed in any convenient order. For example, layers 30, 34, 36, and 38 in Figure 2A may be printed first on label substrate 32 and then adhered to protective layer 40 or, alternatively, may be printed on protective layer 40 in reverse order and then adhered to label substrate 32. Other methods of forming this and the other structures disclosed herein will be apparent to those skilled in the art.

In a preferred embodiment, a liquid crystal display is used that comprises a plurality of liquid crystal layers instead of a single layer. Advantageously, by using a plurality of thinner liquid crystal layers, the voltage required to activate and drive the liquid crystal display may be significantly reduced. A plurality of such thinner liquid crystal layers is preferred because, although individually the change in visual state of each thinner liquid crystal layer will be less perceptible, the changes in visual state of each layer will be cumulative, thereby providing a sufficient overall change in visual appearance of the display between its activated and inactivated states.

For a single layer display, as shown for example in Figure 2A, the liquid crystal layer has a thickness for example of 1.5 to 2.0 μm and is preferably powered by applying a 4- to 5-

volt potential difference across the liquid crystal layer. In a multi-layer display, as shown for example in Figure 2B, the liquid crystal layers may be sufficiently thin such that a potential difference of 1.5 volts need only be applied across each layer to cause a sufficient overall change in visual states. It will be appreciated that the display may include any number of liquid crystal layers, and that the thinness of each layer may be selected accordingly.

In the multi-layer display, each liquid crystal layer can be activated by the electrodes adjacent to each layer. Thus, two adjacent liquid crystal layers can conveniently share a common, preferably transparent, electrode disposed between the layers. If each liquid crystal layer in the display is intended to be activated at the same time, alternating electrodes are preferably electrically coupled together such that only two electrical connectors need to be provided for delivering power to activate the display or display segment.

The battery tester circuit of the present invention may be permanently electrically connected or coupled to the positive and negative battery terminals so that the tester is permanently 'ON', or may be so constructed that either or both ends of the circuit are normally uncoupled from the respective battery terminals, in an 'OFF' mode, until electrically connected or coupled by the consumer, to an 'ON' state. In the latter case, one or more switches may be provided for operation by the consumer in order to selectively connect or couple the battery tester to the battery terminals. Suitable switching mechanisms are known in the art. Preferably, and particularly if a low power consuming electric field-responsive liquid crystal display is used as the display component, the tester circuit is permanently connected or coupled to the battery terminals so as to monitor the status or condition of the battery. Thus, with such a direct and permanent electrical connection, the battery testing circuit may continuously monitor cell capacity, for example, and provide a continuous display of the remaining capacity.

The present invention will now be further illustrated with reference to the accompanying drawings, in which:

Figure 1 is a perspective view of a battery incorporating an on-label battery tester circuit constructed in accordance with an embodiment of the present invention;

Figure 2A is a partial cross-sectional view taken along plane II-II of Figure 1 illustrating a liquid crystal display suitable for use in accordance with the present invention;

Figure 2B is a partial cross-sectional view taken along plane II-II of Figure 1 illustrating a further liquid crystal display suitable for use in accordance with the present invention;

Figure 3 is an electrical circuit diagram in block form of a battery tester circuit constructed in accordance with a preferred embodiment of the second aspect of the present invention;

Figure 4 is a perspective view of a battery provided with a tester circuit as represented in Figure 3, in which the protective outer layer has been removed to show exemplary positioning of the elements on the base layer of a battery label, in accordance with an embodiment of the third aspect of the present invention;

Figure 5 is an electrical circuit diagram in block and schematic form showing an exemplary construction of a display driver circuit (voltage discriminating circuit) coupled to a liquid crystal display in accordance with an embodiment of the first aspect of the present invention;

Figure 6 is a cross-sectional view of an exemplary construction of a transistor that may be printed on a label using conductive and semiconductive inks, suitable for use as a component in a display driver circuit.

Figure 7 is an electrical circuit diagram in schematic form illustrating an exemplary construction of a display driver circuit (oscillating circuit) suitable for use in a display circuit in accordance with the present invention;

Figure 8 is an electrical circuit diagram in block form illustrating a battery tester circuit comprising a liquid crystal display coupled to a display driver circuit, in accordance with a preferred embodiment of the present invention; and

Figure 9 is an electrical circuit diagram in block form illustrating a battery tester circuit comprising a liquid crystal display coupled to a display driver circuit, in accordance with another embodiment of the present invention.

As shown in Figure 1, a battery 10 has a label 15 incorporating a battery testing circuit. The battery testing circuit includes a multi-segmented display 20 having segments 22a-22c that may be selectively activated so as to display the discharge level of the battery 10. A first segment 22a is arranged to indicate "fresh" when the remaining battery capacity is relatively high, a second segment 22b to indicate "good" when the battery discharge level is sufficient for most applications, and a third segment 22c to indicate "replace" when the remaining battery capacity is too low for use in most applications.

Figures 2A and 2B show preferred displays for use in accordance with the present invention. The displays 20 are electric field-responsive liquid crystal displays that undergo a change in visual appearance in response to an electric field applied across the liquid crystal material. As shown in Figure 2A, the liquid crystal display 20 includes a graphics layer 30 that is printed on the outer surface of a label substrate 32. The graphics layer 30 is positioned behind a liquid crystal layer 36 and transparent electrodes 34 and 38, as viewed through transparent protective layer 40. Thus, graphics layer 30 may be selectively blocked or exposed by selective activation of liquid crystal layer 36 via electrical connectors 58 and 60. In the display shown in

Figure 2B, two liquid crystal layers are used in place of the single liquid crystal layer 36 described above in Figure 2A. As shown in Figure 2B, a graphics layer 30 is printed on a label substrate 32. A first transparent electrode 42 is printed on graphics layer 30. On transparent electrode 42 is printed a first liquid crystal layer 44. A second transparent electrode 46 is printed on an opposite side of liquid crystal layer 44. A second liquid crystal layer 48 is printed on second transparent electrode 46, and a third transparent electrode 50 is printed on second liquid crystal layer 48. A transparent protective layer 56 is provided over the structure. Electrodes 42 and 50 are electrically coupled to connector 60 and electrodes 46 and 54 are electrically coupled to connector 58.

As illustrated in Figure 3, a voltage multiplying/oscillating circuit 72 is coupled to the positive and negative terminals of a battery by conductive strips 78 and 80. Voltage multiplying/oscillating circuit 72 delivers an AC driving signal over connectors 74 and 76 to a voltage discriminating circuit 70, which in turn drives the segments 22a, 22b and 22c of liquid crystal display 20 via connectors 58 and 60a, 60b and 60c.

Figure 4 shows a battery 10 with protective layers removed to expose the relative positioning of the components of the battery tester circuit as illustrated in Figure 3. As shown in Figure 4, a conductive strip 80 extends along label substrate 32 to an edge thereof in contact with the negative terminal of battery 10. The negative terminal is electrically insulated from the battery can and positive terminal, and the can is electrically connected to the positive terminal. A conductive strip 78 may contact the battery can through a hole provided in the label substrate 32 by means of a switch pad 82. Thus, the tester circuit may be selectively coupled to the positive terminal of the battery by a consumer, through depression of the switch pad 82.

Figure 5 shows an exemplary circuit for implementing a voltage discriminating circuit 70. As shown in Figure 5, voltage discriminating circuit 70 includes a resistor dividing network

including a first resistor 90 having a first end connected to connector 74 and a first end of a second resistor 92. Connector 74 may be coupled to the positive output terminal of voltage multiplying/oscillating circuit 72 as shown in Figure 3. The second end of first resistor 90 is coupled to connector 58 which is coupled to one or more of the transparent electrodes that are part of liquid crystal display 20. Second resistor 92 has its second end connected to a first end of a third resistor 94 and to a first end of a fourth resistor 96. Third resistor 94 has its second end coupled to the gate of a first transistor 98. Fourth resistor 96 has its second end connected to a first end of a fifth resistor 100 and to the first end of a sixth resistor 102. Fifth resistor 100 preferably has its second end connected to the gate of a second transistor 104. Sixth resistor 102 preferably has its second end connected to a first end of a seventh resistor 106 and to a first end of a thermistor 108. Seventh resistor 106 preferably has its second end connected to the gate of a third transistor 110. The second end of thermistor 108 is preferably coupled to connector 76 and to the cathode of a Zener diode 112. The anode of Zener diode 112 is coupled to the drains of first, second, and third transistors 98, 104, and 110. The sources of transistors 98, 104, and 110 are respectively coupled to connectors 60a, 60b, and 60c which drive the opposing transparent electrodes in segments 22a, 22b, and 22c, respectively, of liquid crystal display 20.

Figure 6 shows a metal-insulator-semiconductor FET (MISFET) transistor that may be used in accordance with the present invention. The MISFET includes an insulating film 120, and a gate electrode 122 printed on one of the faces of insulating film 120. The MISFET also includes a device substrate 124 with electrical contact for the gate electrode 122, and source 126 and drain 128 layers. An organic semiconducting layer 130 is deposited between the source 126 and drain 128 layers.

Figure 7 shows a ring oscillating circuit 72 which may be formed using polymer transistors suitable for printing on a substrate. As shown, the ring oscillating circuit includes

five inverter gates formed of a plurality of MISFETs 132 that may be printed and configured in the same manner as shown in Figure 6. Connectors 78 and 80 may be coupled to the positive and negative battery terminals, and connectors 74 and 76 to a voltage discriminating circuit, as shown in Figure 3.

Figure 8 shows a battery tester circuit in accordance with the present invention. As shown in Figure 8, the tester circuit includes a display driver circuit 150 for generating an oscillating driving signal that is delivered via respective pairs of conductive strips 158 and 160, 162 and 164, 166 and 168 to respective electrodes 170 and 172, 174 and 176, 178 and 180 of a liquid crystal display 152. The display 152 includes three segments to provide battery discharge level indications of "fresh", "good" and "replace", respectively. Each segment is driven by the display driver circuit 150 that is connected to the positive battery terminal by a conductive strip 154 and to the negative battery terminal by a conductive strip 156. The voltages applied to display 152 are appropriately adjusted through the display driver circuit 150 to correspond to the transition voltages that cause the segments of liquid crystal display 152 to change visual states.

As apparent from a comparison of the tester circuit shown in Figure 8 to that shown in Figure 3, the voltage discriminating circuit 70 has been eliminated. In this regard, the voltage discrimination function is carried out by the liquid crystal display 152. Because the liquid crystal material changes between its optical states through a range of voltages, the voltages applied to display 152 may be appropriately adjusted through the use of resistors and display driver circuit 150 to correspond to the transition voltages that cause liquid crystal display 20 to change visual states. Also, by including different resistances connected to conductors 158, 162, and 166, some level of voltage discrimination (?) may be transferred to display driver circuit 150 for actuating different segments of a multi-segmented display. In other words, the voltages applied to the three segments shown

may be scaled so that only one segment of the liquid crystal display is activated at any one time. (Is this not voltage discrimination?)

Figure 9 shows another battery testing circuit in accordance with the present invention. As shown in Figure 9, a display 200 includes many segments 202a-202h to provide a graduated scale for a more accurate discharge level indication ranging between "fresh", "good" and "replace", as designated by indicia 206a-206c, respectively. Each segment 202a-202h is driven by a display driver circuit 208 that includes a voltage discriminating function, via a pair of conductive strips 204a and 204b provided for each segment. Display driver circuit 208 is coupled to the positive battery terminal by a conductive strip 210 and to the negative battery terminal by a conductive strip 212.

CLAIMS

1. A battery tester circuit for a battery comprising:
a display component for displaying information relating to the status of the battery;
and
a display driver component for receiving power from the battery to drive the display component,
wherein at least one of the components is printed on a substrate.
2. A circuit according to claim 1, wherein:
the display component comprises a display printed on the substrate for displaying an indication of the level of discharge of a battery; and
the display driver component comprises a display driver circuit coupled to the display and to the battery for receiving power from the battery to drive the display, and a battery discharge level sensing circuit coupled to the display and to the battery for sensing a discharge level of the battery and for supplying a display signal representing the sensed discharge level to the display, wherein at least one of the circuits is printed on the substrate.
3. A circuit according to claim 2, wherein the battery discharge level sensing circuit is directly coupled to opposite terminals of the battery for continuously monitoring the discharge level of the battery and the display continuously displays an indication of the sensed discharge level.

4. A circuit according to claim 2 or claim 3, wherein both of the circuits are printed on the substrate.
5. A circuit according to any preceding claim, wherein the display component comprises an electric field-responsive liquid crystal display.
6. A circuit according to any preceding claim, wherein the display driver component comprises an oscillator circuit.
7. A circuit according to any preceding in claim, wherein the substrate is a housing for at least one electrochemical cell.
8. A circuit according to claim 1 wherein the display component comprises a liquid crystal display for displaying a level of discharge of a battery, and the display driver component comprises an oscillator circuit coupled to the liquid crystal display and to the battery for receiving power therefrom to drive the liquid crystal display,
wherein at least one of the liquid crystal display and oscillator circuit is printed on the substrate.
9. A circuit according to claim 8, wherein both the liquid crystal display and the oscillator circuit are printed on the substrate.
10. A circuit according to any of claims 5 to 9, wherein the liquid crystal display comprises a polymer-dispersed liquid crystal material.

11. A circuit according to any of claims 5 to 9, wherein the liquid crystal display comprises a polymer liquid crystal material.
12. A circuit according to any preceding claim, wherein the substrate is a battery label.
13. A battery label comprising:
 - a label substrate for covering an outer portion of a battery; and
 - an electric field-responsive liquid crystal display printed on an outer surface of the label substrate for displaying information pertaining to the battery.
14. A battery label according to claim 13, wherein the liquid crystal display comprises:
 - a first electrode printed on the label substrate;
 - a liquid crystal layer printed on the first electrode; and
 - a second electrode printed on the liquid crystal layer.
15. A battery label according to claim 14, wherein the second electrode is formed from a transparent processable conductive polymer.
16. A battery label according to claim 14 or claim 15, wherein the liquid crystal display further comprises:
 - a second liquid crystal layer printed on the second electrode; and
 - a third electrode printed on the second liquid crystal layer.

17. A battery label according to claim 16, wherein the liquid crystal display further comprises:
- a third liquid crystal layer printed on the third electrode; and
 - a fourth electrode printed on the third liquid crystal layer.
18. A battery label according to any of claims 13 to 17, further comprising a display driver circuit printed on the label substrate and coupled to the liquid crystal display and to the battery for receiving power from the battery to drive the liquid crystal display.
19. A battery label according to any of claims 13 to 17, wherein the liquid crystal display comprises at least two display segments printed on the label substrate, and a display driver circuit is coupled to the display segments for separately applying an electric field across each of the display segments.
20. A battery label according to claim 19, wherein each of the display segment comprises a first electrode printed on the label substrate, a liquid crystal layer printed on the first electrode and a second electrode printed on the liquid crystal layer.
21. A battery label according to claim 20, wherein the liquid crystal layer is a layer common to all of the display segments.
22. A battery label according to any of claims 19 to 21, wherein the display driver circuit selectively applies an electric field to one or more of the display segments to indicate a discharge level of the battery.

23. A battery label according to any of claims 18 to 22, wherein the display driver circuit is an oscillator circuit.
24. A battery label according to any of claims 13 to 23, wherein the liquid crystal display displays an indication of the battery discharge level.
25. A battery label according to claim 24, wherein the liquid crystal display is responsive to an open circuit voltage of the battery to change visual appearance, thereby displaying an indication of the discharge level of the battery.
26. A battery label according to claim 24 or claim 25, further comprising a discharge level sensing circuit printed on the label substrate and coupled to the battery for providing an indication of the battery discharge level to the liquid crystal display.
27. A battery label according to any of claims 24 to 26, wherein the liquid crystal display continuously displays an indication of the battery discharge level.
28. A battery label according to any of claims 13 to 27, wherein the liquid crystal display comprises a polymer-dispersed liquid crystal material.
29. A battery label according to any of claims 13 to 27, wherein the liquid crystal display comprises a polymer liquid crystal material.

30 A battery comprising:

an electrochemical cell provided in a battery housing and having a positive terminal and a negative terminal; and

a battery tester circuit as defined in any of claims 1 to 12, wherein

the substrate is a label substrate disposed on an exterior surface of the battery housing;

a discharge level sensing circuit is directly coupled to the terminals for continuously sensing a discharge level of the battery; and

the display component is a liquid crystal display printed on the label substrate and coupled to the discharge level sensing circuit for continuously displaying an indication of the sensed level of discharge of the battery.

31. A battery according to claim 30 comprising a plurality of internally connected electrochemical cells provided in the battery housing.

1/4

Fig. 1

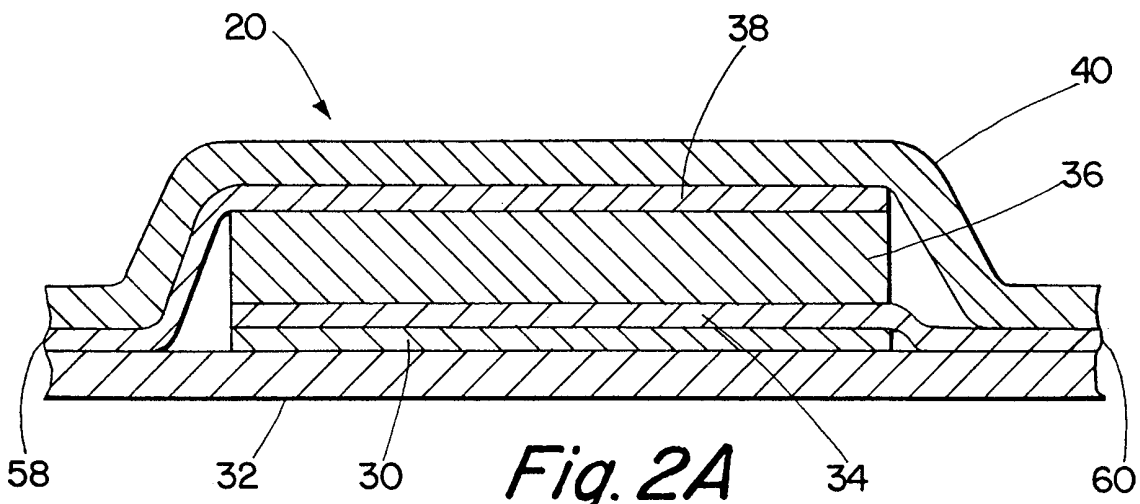
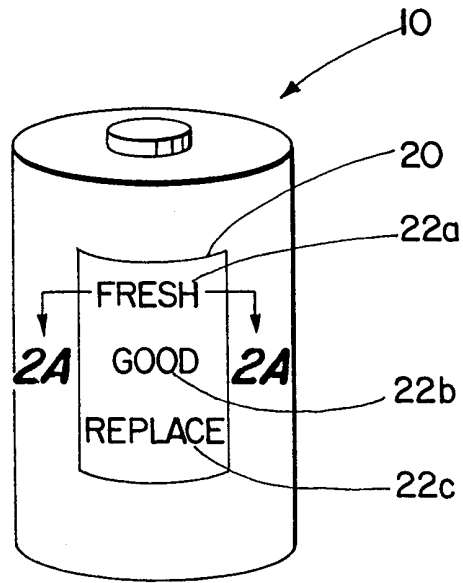

Fig. 2A

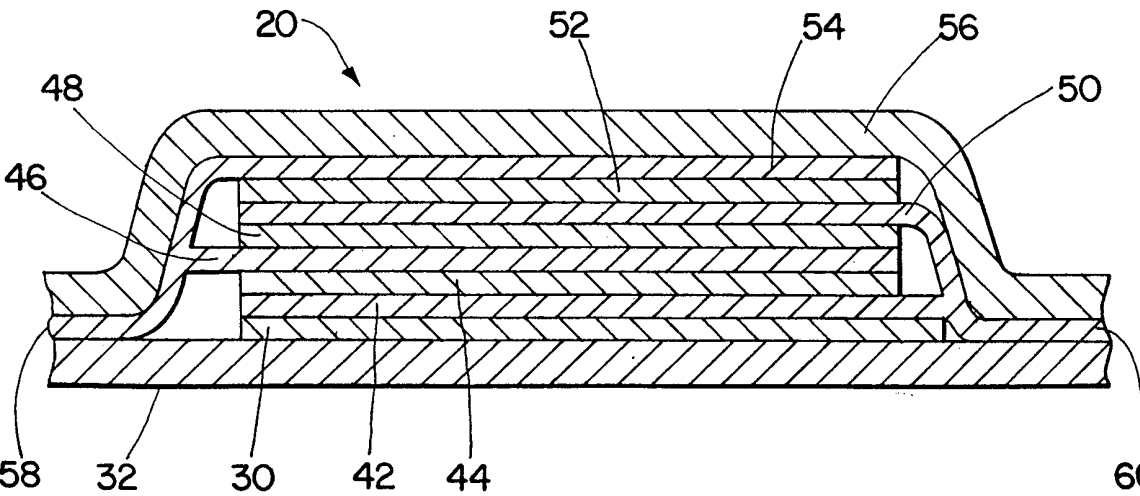

Fig. 2B

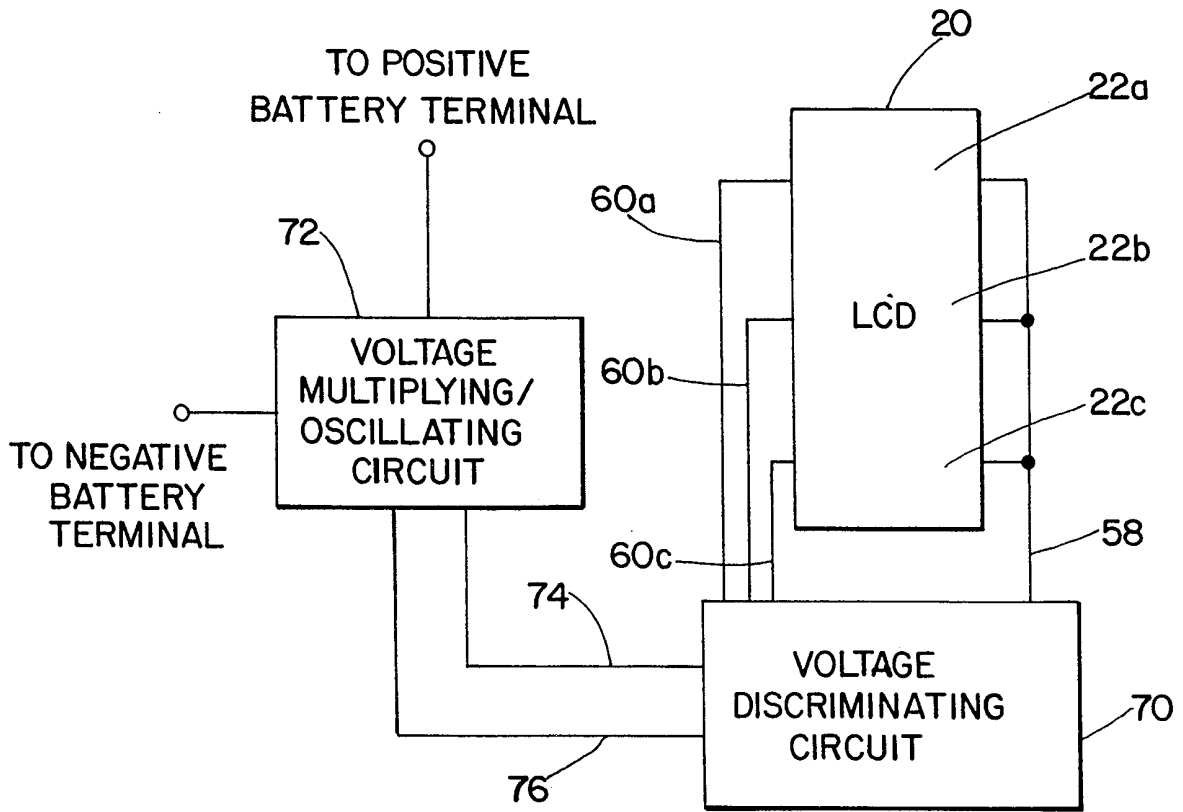

Fig. 3

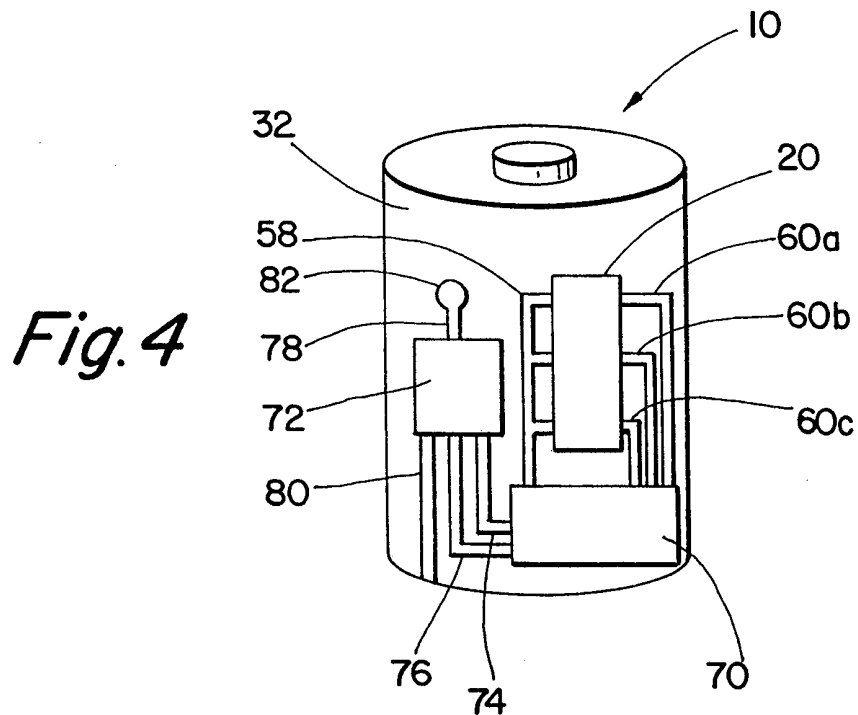

Fig. 4

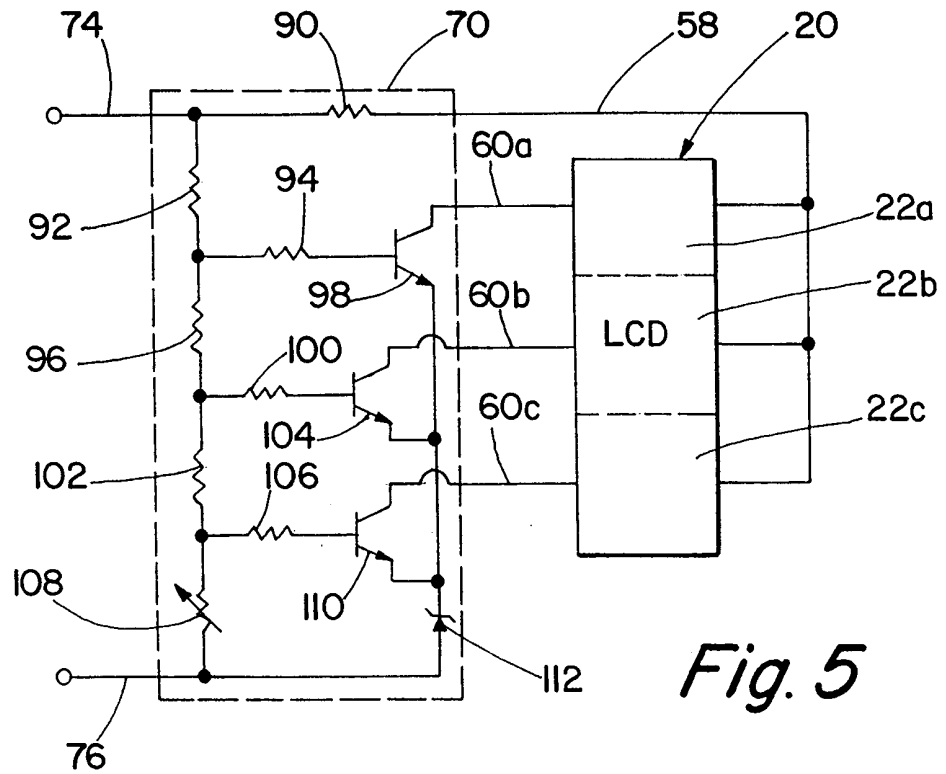

Fig. 5

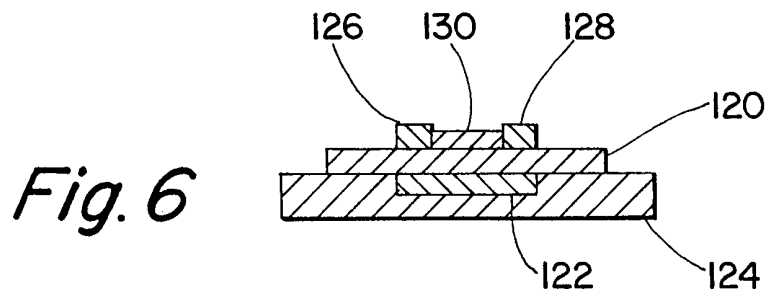

Fig. 6

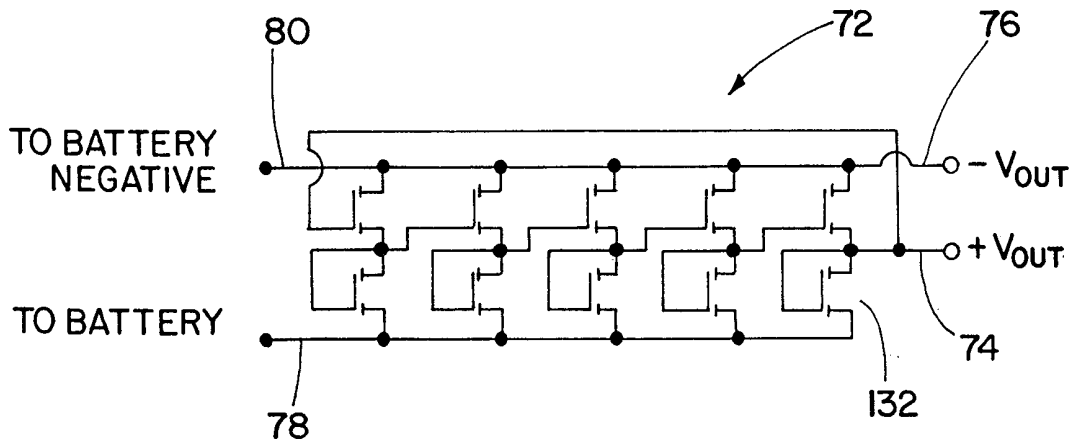
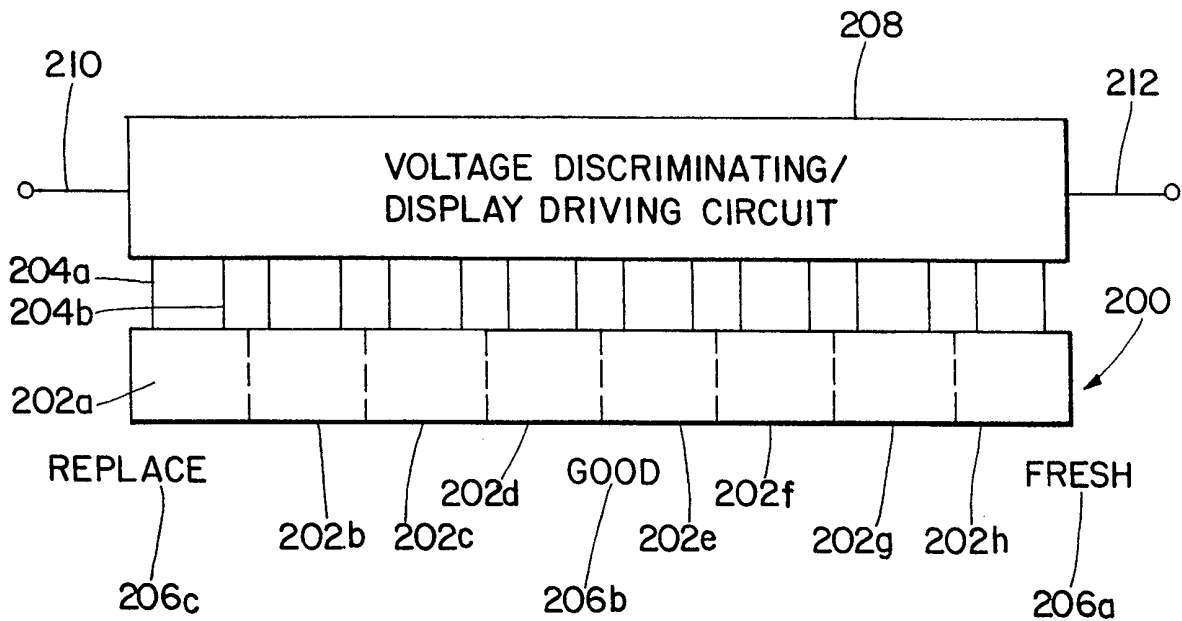
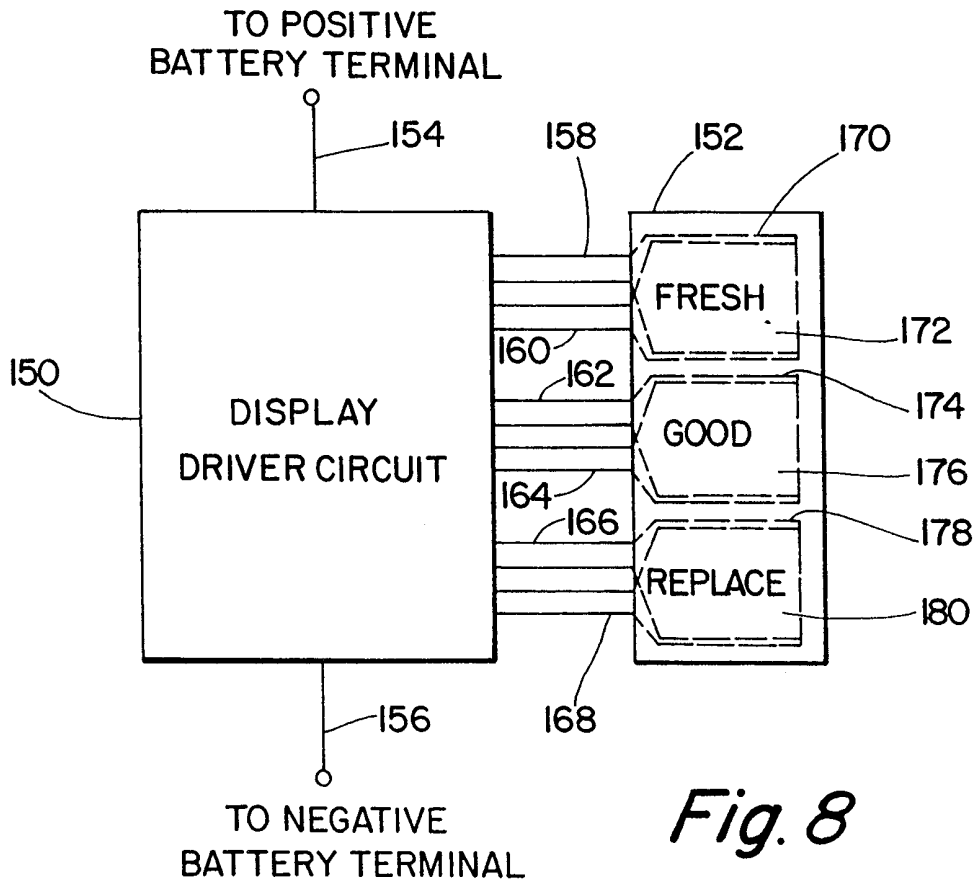

Fig. 7



INTERNATIONAL SEARCH REPORT

International Application No

PCT/US 98/18243

A. CLASSIFICATION OF SUBJECT MATTER
 IPC 6 H01M10/48 G01R31/36

According to International Patent Classification (IPC) or to both national classification and IPC

B. FIELDS SEARCHED

Minimum documentation searched (classification system followed by classification symbols)

IPC 6 H01M G01R

Documentation searched other than minimum documentation to the extent that such documents are included in the fields searched

Electronic data base consulted during the international search (name of data base and, where practical, search terms used)

C. DOCUMENTS CONSIDERED TO BE RELEVANT

Category °	Citation of document, with indication, where appropriate, of the relevant passages	Relevant to claim No.
P, X	PATENT ABSTRACTS OF JAPAN vol. 097, no. 011, 28 November 1997 -& JP 09 200966 A (SHARP CORP), 31 July 1997	1, 4
P, Y A	see abstract	5, 6 7-13, 30
Y	PATENT ABSTRACTS OF JAPAN vol. 096, no. 011, 29 November 1996 -& JP 08 185895 A (SONY CORP), 16 July 1996	5, 6
A	see abstract	7
A	PATENT ABSTRACTS OF JAPAN vol. 095, no. 011, 26 December 1995 & JP 07 211358 A (MAZDA MOTOR CORP), 11 August 1995 see abstract	1
	-/--	

Further documents are listed in the continuation of box C.

Patent family members are listed in annex.

° Special categories of cited documents :

- "A" document defining the general state of the art which is not considered to be of particular relevance
- "E" earlier document but published on or after the international filing date
- "L" document which may throw doubts on priority claim(s) or which is cited to establish the publication date of another citation or other special reason (as specified)
- "O" document referring to an oral disclosure, use, exhibition or other means
- "P" document published prior to the international filing date but later than the priority date claimed

- "T" later document published after the international filing date or priority date and not in conflict with the application but cited to understand the principle or theory underlying the invention
- "X" document of particular relevance; the claimed invention cannot be considered novel or cannot be considered to involve an inventive step when the document is taken alone
- "Y" document of particular relevance; the claimed invention cannot be considered to involve an inventive step when the document is combined with one or more other such documents, such combination being obvious to a person skilled in the art.
- "&" document member of the same patent family

Date of the actual completion of the international search

8 December 1998

Date of mailing of the international search report

21/12/1998

Name and mailing address of the ISA

European Patent Office, P.B. 5818 Patentlaan 2
 NL - 2280 HV Rijswijk
 Tel. (+31-70) 340-2040, Tx. 31 651 epo nl,
 Fax: (+31-70) 340-3016

Authorized officer

Lopez-Carrasco, A

INTERNATIONAL SEARCH REPORT

International Application No

PCT/US 98/18243

C.(Continuation) DOCUMENTS CONSIDERED TO BE RELEVANT

Category °	Citation of document, with indication, where appropriate, of the relevant passages	Relevant to claim No.
A	PATENT ABSTRACTS OF JAPAN vol. 011, no. 009 (P-534), 10 January 1987 & JP 61 186872 A (ASAHI OPTICAL CO LTD), 20 August 1986 see abstract -----	1