

(19) World Intellectual Property Organization
International Bureau



(43) International Publication Date
30 November 2000 (30.11.2000)

PCT

(10) International Publication Number
WO 00/71422 A1

- (51) International Patent Classification⁷: B65B 31/04
- (21) International Application Number: PCT/EP00/04518
- (22) International Filing Date: 18 May 2000 (18.05.2000)
- (25) Filing Language: English
- (26) Publication Language: English
- (30) Priority Data:
99110049.6 21 May 1999 (21.05.1999) EP
- (71) Applicant (for all designated States except US):
ARACARIA B.V. [NL/NL]; Leidsekaade 98, NL-1017 PP
Amsterdam (NL).
- (72) Inventor; and
- (75) Inventor/Applicant (for US only): LANZA, Fabrizio
[IT/IT]; Via Mosè Bianchi 3, I-20063 Cernusco sul Nav-
iglio (IT).
- (74) Agent: VIERING, JENTSCHURA & PARTNER;
Steinsdorfstr. 6, D-80538 München (DE).
- (81) Designated States (national): AE, AG, AL, AM, AT, AU,
AZ, BA, BB, BG, BR, BY, CA, CH, CN, CR, CU, CZ, DE,
DK, DM, DZ, EE, ES, FI, GB, GD, GE, GH, GM, HR, HU,
ID, IL, IN, IS, JP, KE, KG, KP, KR, KZ, LC, LK, LR, LS,
LT, LU, LV, MA, MD, MG, MK, MN, MW, MX, NO, NZ,
PL, PT, RO, RU, SD, SE, SG, SI, SK, SL, TJ, TM, TR, TT,
TZ, UA, UG, US, UZ, VN, YU, ZA, ZW.
- (84) Designated States (regional): ARIPO patent (GH, GM,
KE, LS, MW, SD, SL, SZ, TZ, UG, ZW), Eurasian patent
(AM, AZ, BY, KG, KZ, MD, RU, TJ, TM), European patent
(AT, BE, CH, CY, DE, DK, ES, FI, FR, GB, GR, IE, IT, LU,
MC, NL, PT, SE), OAPI patent (BF, BJ, CF, CG, CI, CM,
GA, GN, GW, ML, MR, NE, SN, TD, TG).
- Published:
— With international search report.

[Continued on next page]

(54) Title: A HAND-HELD SUCTION PUMP

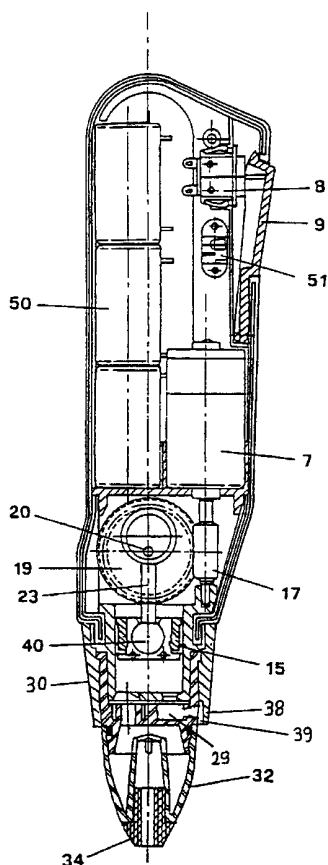

(57) Abstract: A hand-held suction pump for creating a vacuum in a container (2) provided with a suction valve (3), comprising an elongated outer casing in which an electric motor (7) and a piston pump (14, 15) driven by the motor (7) are accommodated, wherein the pump chamber (14) of the piston pump is connected by an inlet valve and a suction duct (28) to a hollow tip (34) at the free end of the casing for direct coupling with the suction valve of the container, the pump chamber being further connected by an outlet valve to an exhaust duct (29) having a duct opening on the outer surface of the wall of the outer casing for porting an exhaust flow to the exterior of the outer casing. In order to reduce noise caused by the exhaust flow, the duct opening of the exhaust duct (29) is overlapped by a baffle (38) which is separated by a gapped distance from the outer surface of the wall of the outer casing so as to deflect the exhaust flow exiting the duct opening by a substantial angle.



WO 00/71422 A1



For two-letter codes and other abbreviations, refer to the "Guidance Notes on Codes and Abbreviations" appearing at the beginning of each regular issue of the PCT Gazette.

A Hand-Held Suction Pump

The invention refers to a hand-held suction pump for creating a vacuum in a container provided with a suction valve, comprising
5 an elongated outer casing in which an electric motor and a piston pump driven by the motor are accommodated, wherein the pump chamber of the piston pump is connected by an inlet valve and a suction duct to a hollow tip at the free end of the casing for direct coupling with the suction valve of the
10 container, the pump chamber being further connected by an outlet valve to an exhaust duct having a duct opening on the outer surface of the wall of the outer casing for porting an exhaust flow to the exterior of the outer casing.

15 A hand-held suction pump of the aforementioned kind is disclosed in EP 0 510 360 A. It is useful especially in the household field for creating a high vacuum in household containers containing food, either solid, semi-solid or liquid to be preserved in the absence of air or air access,
20 particularly in the absence of oxygen.

The known hand-held suction device has been proven to satisfy the aforementioned need but may be subject to further improvement regarding some noise generated by the intermittent
25 air flow which must necessarily exit the device during operation.

According to the invention, a hand-held suction pump of the present type is provided and constructed primarily so as to
30 effect a reduction of the noise generated in exhausting the air as it is sucked out during evacuation of the container.

This aim is attained by the invention in that the duct opening of the exhaust duct on the outer surface of the wall of the
35 outer casing of the hand-held suction pump is overlapped by a baffle which is separated by a gapped distance from the outer surface of the wall of the outer casing so as to deflect the exhaust flow exiting the duct opening by a substantial angle

before the exhaust flow is discharged to the surrounding air.

By deflecting the exhaust flow exiting the duct opening of the exhaust duct by a substantial angle, it is possible to reach a substantial reduction of the noise generated by the air streams which intermittently exit the device during operation. The magnitude of the deflecting angle mainly depends on the shape and direction of the exhaust duct with respect to the contour of the outer surface of the casing at the opening site of the duct as well as on the construction and shape of the opening of the duct. In most cases, the deflecting angle is 60° to 120° . If the exhaust duct extends mainly in a radial direction with respect to the axis of the outer casing of the suction pump and if the outer surface of the casing at the opening site extends in parallel with said axis, the amount of the deflecting angle will be substantially 90° .

Further, the deflecting direction may be varied to a great extent according to the construction of the contours of the exhaust duct and the outer surface of the casing. Thus, it is possible to deflect the exhaust flow at the baffle into the axial direction of the outer casing of the suction pump toward the top portion of the casing. In other cases, the deflection direction may be lateral. Further, it is possible to construct outlet gaps or openings at both lateral or axial sides of the baffle to simultaneously split apart the exhaust flow exiting the duct opening of the exhaust duct. At present, it is preferred that an exit port is formed between the baffle and the wall of the outer casing designed for directing the exhaust flow in a direction substantially parallel to the contour of the outer casing surface toward the hollow tip at the free end of the casing. In this way, the existing exhaust flow will be directed away from the user holding the the suction pump in one hand during operation of the device.

35

Moreover, the construction of the baffle and of its connection to the outer casing may be freely chosen as desired according to the casing construction. At present, it is preferred to form

the baffle by a wall portion of a sleeve attached to the outer casing. Such a construction of the baffle is particularly of advantage if the suction pump comprises an interchangeable terminal cap supporting the hollow tip at the free end of the casing, the terminal cap being attached by a removable sleeve which also serve to form the baffle of the invention.

The invention is further described by way of preferred embodiments as disclosed in the drawings.

10

Figure 1 is an axonometric view showing the hand-held suction pump according to the invention being used to establish a vacuum in a container provided with a suction valve;

Figure 2 is an exploded axonometric view of a preferred embodiment of the suction pump shown in figure 1;

Figure 3 is a mid-section of the suction pump according to the invention;

Figure 4 is a different section of the suction pump;

Figure 5 is a side-view of a possible modified embodiment of the shape of the suction pump shown in the previous figures;

Figure 6 is a mid-section of a different embodiment of the suction pump according to the invention.

With reference to figures 1 to 3, the suction pump according to the invention has been indicated as a whole with reference number 1. Figure 1 shows this suction pump 1 being applied to suction valve 3 of a container 2, in which a vacuum is to be established.

30

As is more easily visible in the exploded view of figure 2, the hand-held suction pump 1 comprises an elongated outer casing partly formed by two substantially identical halves 4 and 5, assembled with screws 6. In the upper part of the outer casing, an electric motor 7 is disposed to be operated by a press switch 8 actuated by a pivoted key 9. In these figures part of a power cable 10 is shown which is present for case that the motor 7 is driven by line current. It is evident, however, that

the suction pump could also be driven by a battery, which is possibly rechargeable by line current. The figures also depict three LEDs 11 of different colours, the status of which is determined by the load of the motor 7 and which serve to signal the degree of vacuum reached in the container during pump operation.

A support cage 13 is provided below motor 7 in order to hold the cylinder 14 of the pump and the speed reduction group (to be described later) and which transmits the reciprocating motion to the piston 15.

A pinion 17 is force-fit on the outward end of the shaft 16 of the motor 7, and this pinion 17 may be integrated with an impeller 18 to cool the motor. The pinion 17 is engaged with a crown gear 19 rotatably mounted on a shaft 20 held by the cage 13. An eccentric hollow 37 is provided inside the crown gear 19 and serves to support a connecting rod 23, the free end of which supports the piston 15.

In particular, said free end has the shape of a sphere 40 located in semispheric seating 41 of two symmetrical pads 42, opposed to the piston. The pads 42 are fixed to a bush 43, which is inserted onto these pads upon interposition of a gasket 44.

In the embodiment illustrated in figures 1 to 3, shaft 20, which serves as the axis of the crown gear 19, is perpendicular to the motor shaft 16, and the piston-cylinder unit of the suction pump is perfectly aligned with the axis of the motor 7. Hence, the suction pump is substantially straight-lined. However, it is evident that the axis of the cylinder 4 can be inclined up to 90° with respect to the motor shaft 16 in a plane perpendicular to the plane of the page in figure 3 while maintaining shaft 20 in a fixed position.

Below cylinder 14 there is a valve body 24, which is separated from cylinder 14 by an interposed diaphragm valve 25 effective

as an inlet valve and an outlet valve, respectively. At the bottom of cylinder 14 there are two openings 26 and 27, which are respectively connected through the diaphragm valve 25 to a suction duct 28 and to a radially extending exhaust duct 29 of the valve body 24.

As shown in figure 3, the valve body 24, the diaphragm valve 25 and the cylinder 14 (the latter might also be integral with cage 13) are assembled by means of a threaded sleeve 30, which is threaded on a thread 31 formed at the lower external ends of the two device casing halves 4 and 5. The outside duct opening of the exhaust duct 29 is overlapped by a baffle 38 which is separated by a gapped distance from the outer surface of the wall of the outer casing so as to deflect the exhaust flow exiting the duct opening by an substantial angle before the exhaust flow is discharged to the surrounding air. In the present embodiments shown in the drawings, the baffle 38 is formed by a wall portion of the lower free end wall of the sleeve 30. To this end, the sleeve is recessed at its inner wall along the area where the sleeve is overlapping the duct opening thereby bringing about the gapped distance between the baffle 38 and the outer casing wall and leaving an exit port 39 between the baffle and the outer casing wall for directing the exhaust flow in a direction substantially parallel to the axis of the outer casing toward the hollow tip 34 at the free end of the casing.

In another embodiment, not shown in the drawings, the outlet duct opening of the exhaust duct 29 may upwardly be displaced by a certain distance thereby enabling the sleeve 30 to be made shorter.

A terminal cap 32 is fixed to the body valve 24, e.g. by means of a bayonet or a threaded joint, with a locking ring 31 interposed therebetween. This terminal cap, preferably made of a transparent material, has an internal seat 33 for the press fit of a tip 34 made of a flexible material such as rubber. It is this tip which will engage the seating of suction valve 3

provided on the container 2. In the embodiment shown in the attached figures, the tip 34 and the corresponding seating of suction valve 3 have the shape of complementary truncated cones.

5

The seat 33 of the terminal cap 32 has a solid end 35, as shown in the exploded view of figure 2, and side openings 36, through which the air sucked from container 2 is forced during pump operation. In this way, any possible condensate is collected in the terminal cap 32 and is subsequently drained by removing the cap from the pump. The transparency of the cap 32 allows a visual check for accumulation of condensate in the cap.

10

As an alternative or in addition to the LEDs 11 signalling the degree of vacuum established, a mechanical indicator may be provided comprising a cylinder 45 whose lower end is connected to the suction tip 34 and therefore to the container 2 in which a vacuum is to be established and in which this connection is through a duct (not shown) in the sidewall of the body valve 24. A piston 46 is situated with its gasket 47 within the cylinder 45 and is subjected to an upward force applied by spring 48.

15

20

The vacuum obtained in container 2 during the operation of the suction pump tends to suck the piston 46 downwardly against the force of the spring 48. The position of this spring 48 is visible through the transparent cylinder 45 as well as through an opening 49 arranged in one of the two halves 4 and 5, and hence serves as an indication of the degree of vacuum created.

25

The operation of the hand-held suction pump according to the invention is as follows.

30

The suction pump is held with one hand, as schematically indicated in figure 1 (or the opposite hand can be used to actuate the switch with the forefinger) and is positioned directly on a container 2 in which a vacuum is to be established by inserting the tip 34 in the seating of the

corresponding valve 3 of the container. The motor 7 is actuated by pushing the pivot key 9, thus rotating the conical pinion 17. This pinion 17 transmits the rotation to the crown gear 19 which, through the eccentric hollow 37, moves the connecting rod 23 - piston 15 group by reciprocative motion. During the upward movement of the piston corresponding to the suction phase, the air sucked from the container passes through the openings 36, leaves the condensate and solid particles, if any, in the terminal cap 32 and enters the chamber of the cylinder passing through the duct 28 of the valve body 24, through the diaphragm valve 25 and through the opening 26 of the cylinder bottom. In this phase, the opening 27 in the cylinder bottom is obviously closed by the diaphragm valve 25. During the downward movement of the piston, the diaphragm valve 25 closes the opening 26 and opens the opening 27 of the cylinder bottom 14, thus exhausting the air present in the cylinder through the duct 29 provided in the valve body 24. Since the exhaust flow is deflected by baffle 38 by angle of almost 90°, the noise generated by the exhaust flow will be on a low level. For further noise reduction, a standard sponge filter (not shown) may be press-fitted into the exhaust duct 29.

As the vacuum increases in container 2, the load of the motor 7 increases. This increase is sensed by suitable electronic circuitry and is signalled to the user by the selective lighting of the LEDs 11 indicating the degree of vacuum reached in the container.

In the cases of a mechanical indicator, the degree of vacuum reached is signalled by the position of the piston 46, which moves as the vacuum in the container increases.

The transmission system between motor and suction pump according to the invention is particularly advantageous when the above elements are perfectly aligned, but can be conveniently used up to an inclination of 45° of these elements.

Even though in figure 1 a rigid container is shown, it is evident that the suction pump according to the invention could be used with any other type of container, for instance with flexible ones, provided that they have a valve suitable to seat
5 the tip 34, which has a convenient square section but, being interchangeable, could be substituted with a tip having a different cross section, for example a pyramidal one.

10 In figure 5 and 6 a different possible embodiment of the invention is shown wherein, in place of the pinion 17, a worm, indicated with reference number 17, is located offset with respect to the rod 23, which actuates a crown gear 19 having a suitable profile.

15 According to this embodiment feeder batteries 50 are provided, overlapped on a side of the suction pump. With batteries 51, a socket for the battery recharge or, in case, for the feeding by the line current is provided.

20 Without any substantial change other than simply inverting the functioning of the diaphragm valve 25 the pump can be actuated as a compressor, making it possible to utilize the device according to the invention to blow air into a container, rather than to suck it out.

25

Claims

1. A hand-held suction pump for creating a vacuum in a container (2) provided with a suction valve (3), comprising an elongated outer casing in which an electric motor (7) and a piston pump (14, 15) driven by the motor (7) are accommodated, wherein the pump chamber (14) of the piston pump is connected by an inlet valve and a suction duct (28) to a hollow tip (34) at the free end of the casing for direct coupling with the suction valve of the container, the pump chamber being further connected by an outlet valve to an exhaust duct (29) having a duct opening on the outer surface of the wall of the outer casing for porting an exhaust flow to the exterior of the outer casing, characterized in that the duct opening of the exhaust duct (29) is overlapped by a baffle (38) which is separated by a gapped distance from the outer surface of the wall of the outer casing so as to deflect the exhaust flow exiting the duct opening by a substantial angle.
2. A hand-held suction pump according to claim 1, characterized in that said angle is an angle of substantially 90°.
3. A hand-held suction pump according to claim 1 or 2, characterized in that an exit port (39) is formed between the baffle (38) and the wall of the outer casing designed for directing the exhaust flow in a direction substantially parallel to the axis of the outer casing toward the hollow tip (34) at the free end of the casing.
4. A hand-held suction pump according to any of claims 1 to 3, characterized in that the baffle (38) is formed by a wall portion of a sleeve (30) attached to the outer casing.
5. A hand-held suction pump according to claim 4, characterized in that the hollow tip (34) is disposed at a terminal cap (32) of the outer casing removably mounted by means of the sleeve (30).

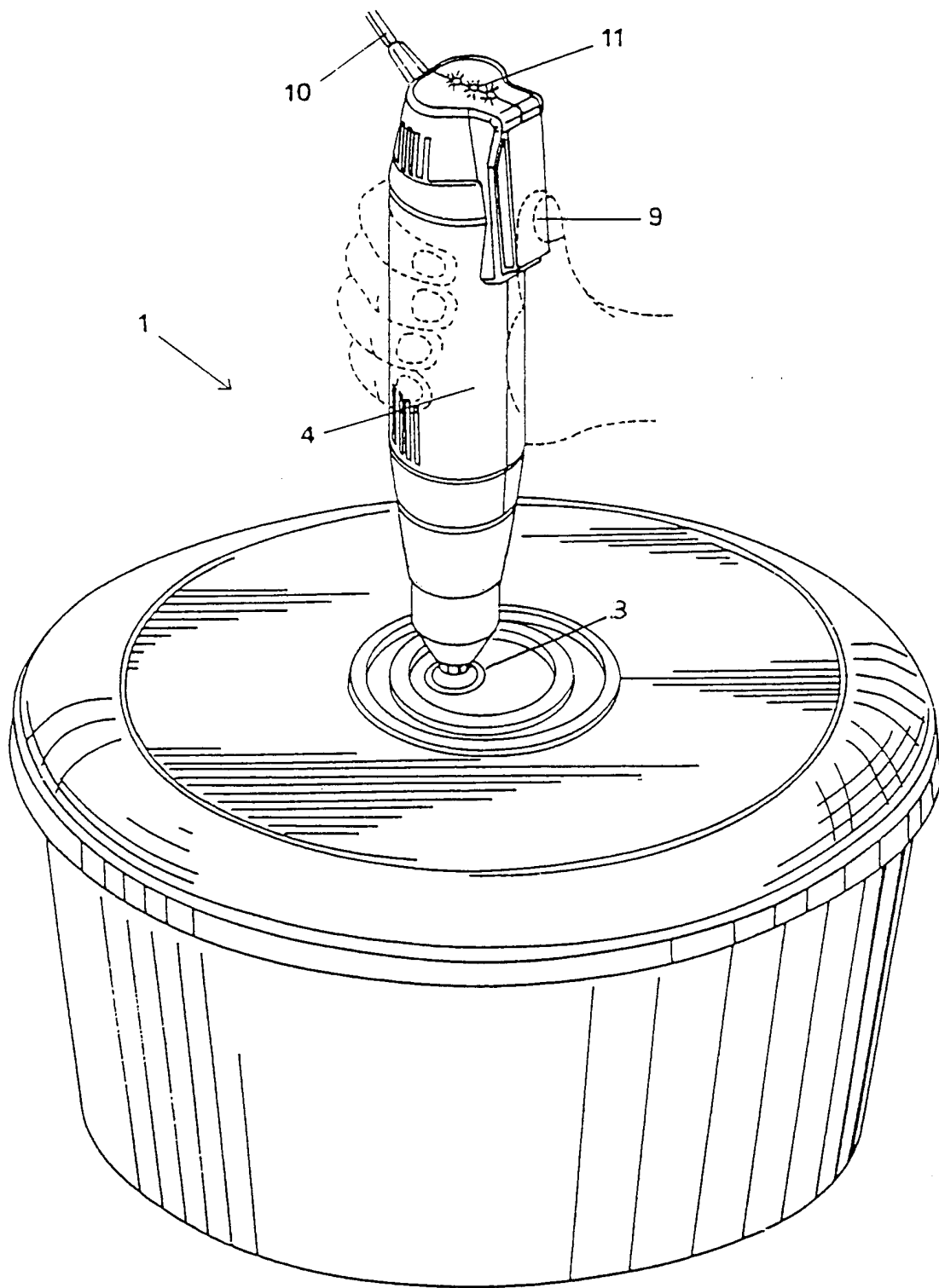

FIG 1

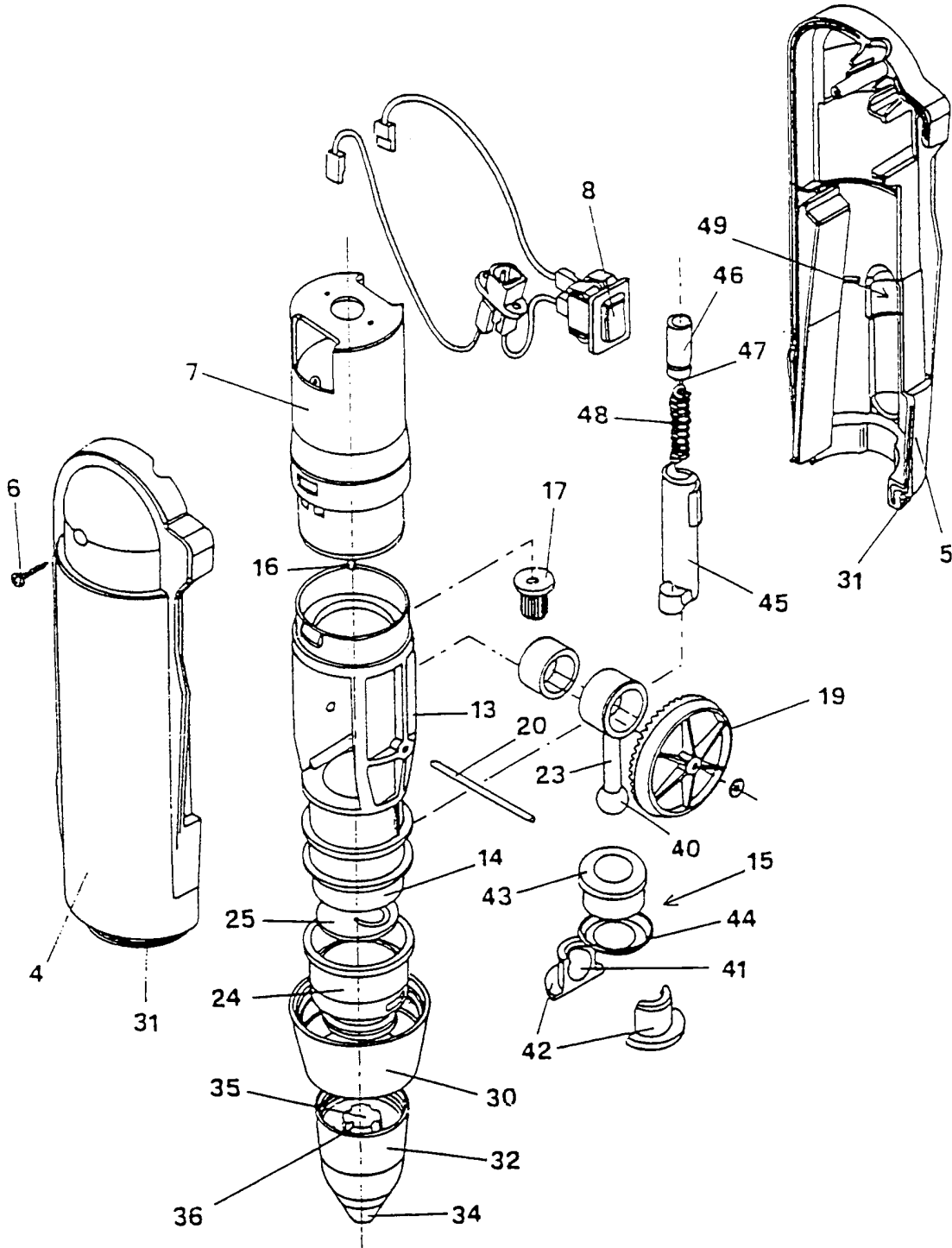

FIG 2

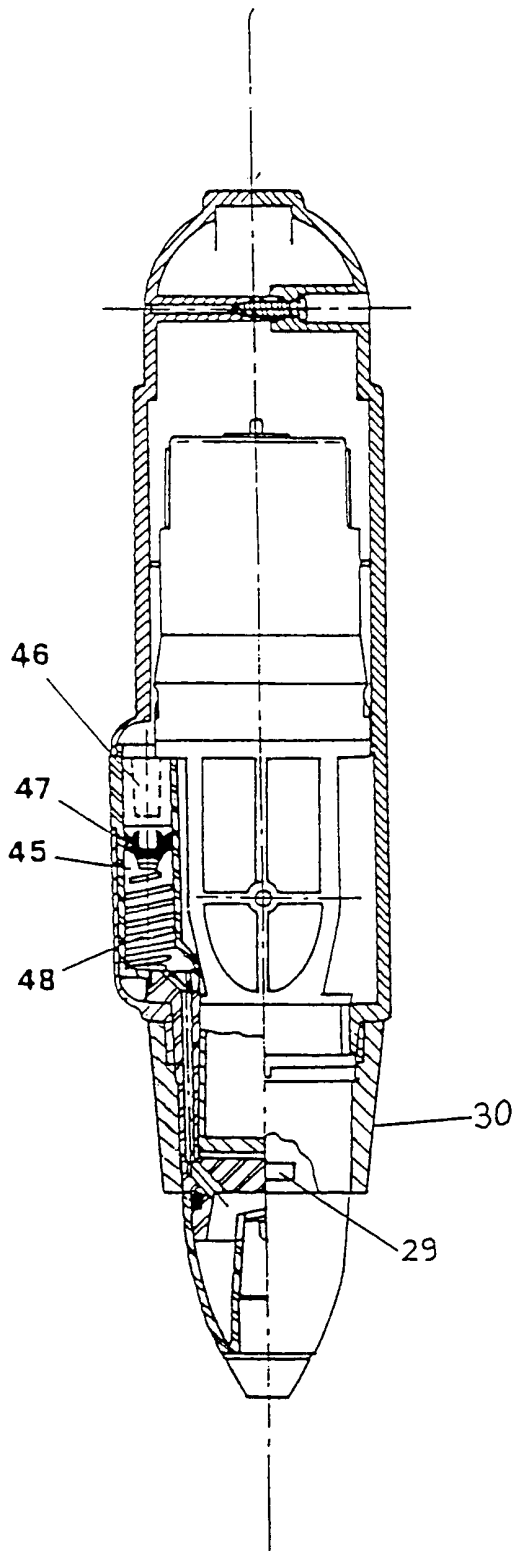

FIG 4

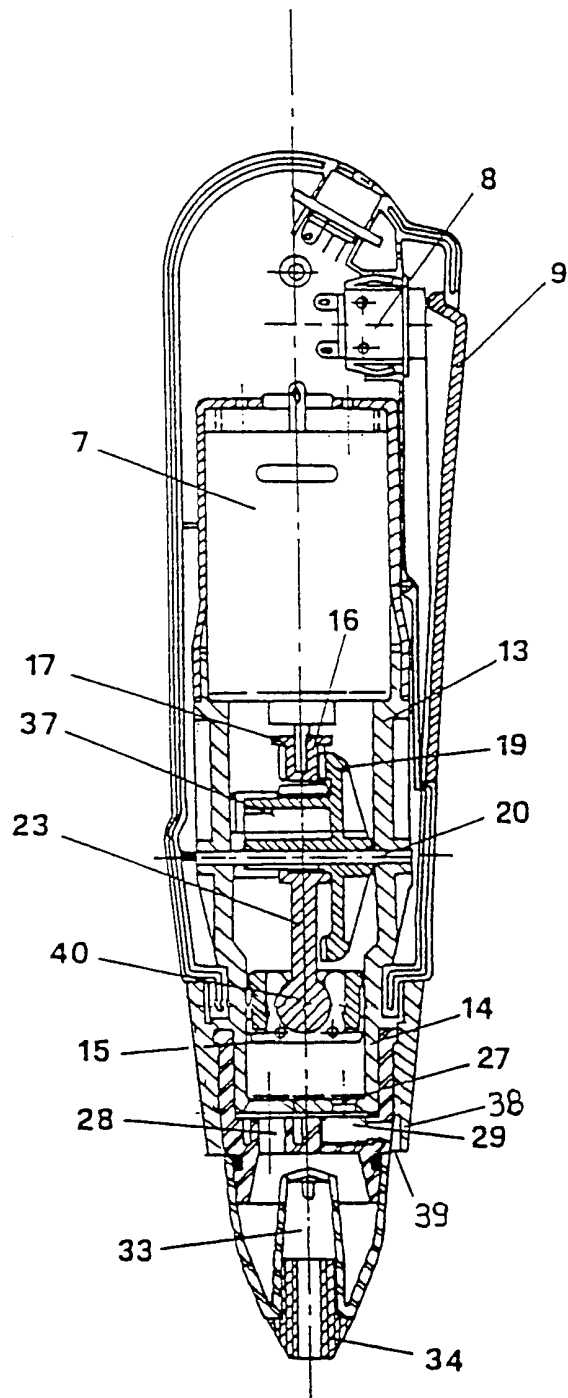

FIG 3

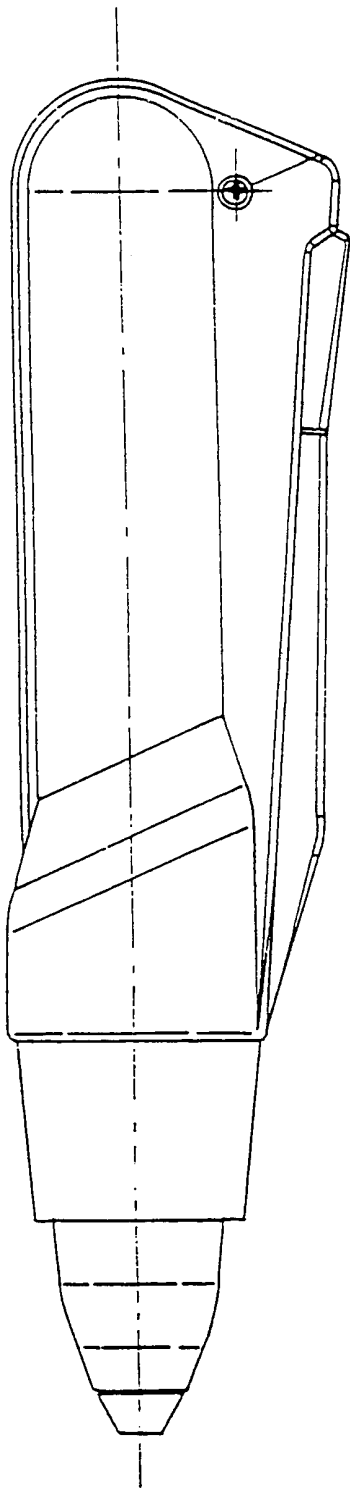

FIG 5

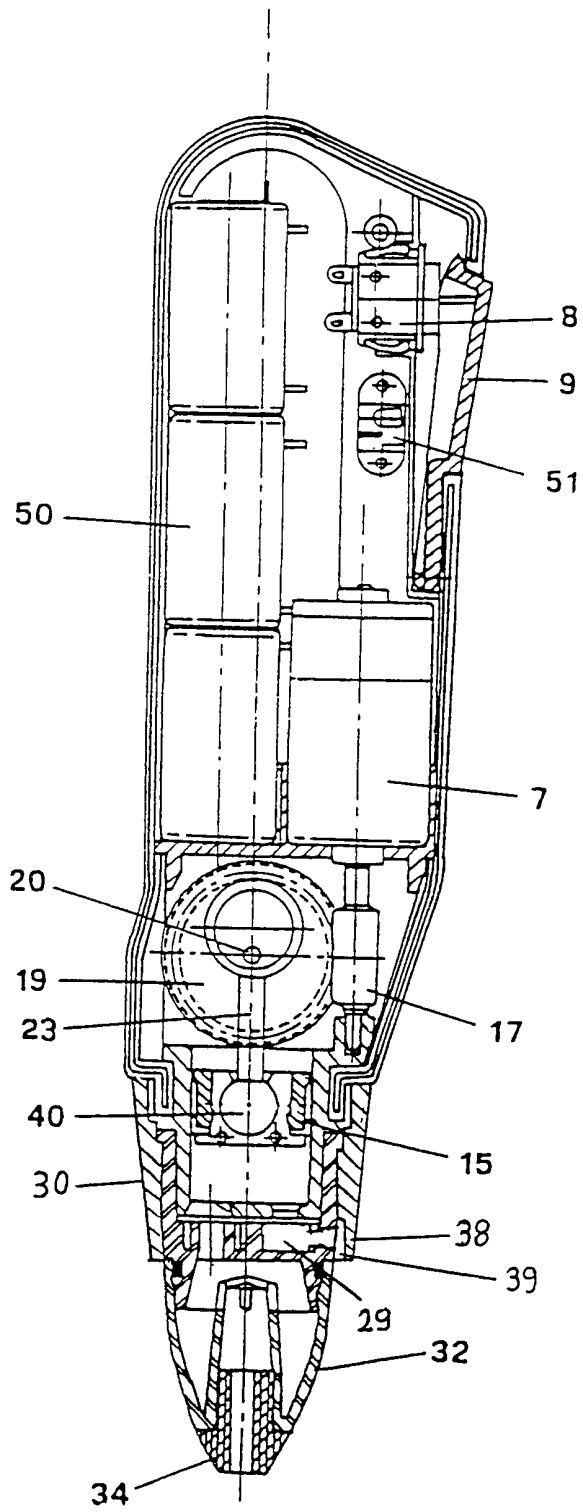

FIG 6

INTERNATIONAL SEARCH REPORT

International Application No
PCT/EP 00/04518

A. CLASSIFICATION OF SUBJECT MATTER IPC 7 B65B31/04				
According to International Patent Classification (IPC) or to both national classification and IPC				
B. FIELDS SEARCHED				
Minimum documentation searched (classification system followed by classification symbols) IPC 7 B65B				
Documentation searched other than minimum documentation to the extent that such documents are included in the fields searched				
Electronic data base consulted during the international search (name of data base and, where practical, search terms used) EPO-Internal				
C. DOCUMENTS CONSIDERED TO BE RELEVANT				
Category °	Citation of document, with indication, where appropriate, of the relevant passages	Relevant to claim No.		
A	WO 97 17259 A (TILIA) 15 May 1997 (1997-05-15) page 8, line 13-29; figure 2A -----	1		
<input type="checkbox"/> Further documents are listed in the continuation of box C.				
<input checked="" type="checkbox"/> Patent family members are listed in annex.				
° Special categories of cited documents :				
<table style="width: 100%; border: none;"> <tr> <td style="width: 50%; border: none; vertical-align: top;"> *A* document defining the general state of the art which is not considered to be of particular relevance *E* earlier document but published on or after the international filing date *L* document which may throw doubts on priority claim(s) or which is cited to establish the publication date of another citation or other special reason (as specified) *O* document referring to an oral disclosure, use, exhibition or other means *P* document published prior to the international filing date but later than the priority date claimed </td> <td style="width: 50%; border: none; vertical-align: top;"> *T* later document published after the international filing date or priority date and not in conflict with the application but cited to understand the principle or theory underlying the invention *X* document of particular relevance; the claimed invention cannot be considered novel or cannot be considered to involve an inventive step when the document is taken alone *Y* document of particular relevance; the claimed invention cannot be considered to involve an inventive step when the document is combined with one or more other such documents, such combination being obvious to a person skilled in the art. *&* document member of the same patent family </td> </tr> </table>			*A* document defining the general state of the art which is not considered to be of particular relevance *E* earlier document but published on or after the international filing date *L* document which may throw doubts on priority claim(s) or which is cited to establish the publication date of another citation or other special reason (as specified) *O* document referring to an oral disclosure, use, exhibition or other means *P* document published prior to the international filing date but later than the priority date claimed	*T* later document published after the international filing date or priority date and not in conflict with the application but cited to understand the principle or theory underlying the invention *X* document of particular relevance; the claimed invention cannot be considered novel or cannot be considered to involve an inventive step when the document is taken alone *Y* document of particular relevance; the claimed invention cannot be considered to involve an inventive step when the document is combined with one or more other such documents, such combination being obvious to a person skilled in the art. *&* document member of the same patent family
A document defining the general state of the art which is not considered to be of particular relevance *E* earlier document but published on or after the international filing date *L* document which may throw doubts on priority claim(s) or which is cited to establish the publication date of another citation or other special reason (as specified) *O* document referring to an oral disclosure, use, exhibition or other means *P* document published prior to the international filing date but later than the priority date claimed	*T* later document published after the international filing date or priority date and not in conflict with the application but cited to understand the principle or theory underlying the invention *X* document of particular relevance; the claimed invention cannot be considered novel or cannot be considered to involve an inventive step when the document is taken alone *Y* document of particular relevance; the claimed invention cannot be considered to involve an inventive step when the document is combined with one or more other such documents, such combination being obvious to a person skilled in the art. *&* document member of the same patent family			
Date of the actual completion of the international search <p style="text-align: center; font-size: 1.2em;">28 August 2000</p>		Date of mailing of the international search report <p style="text-align: center; font-size: 1.2em;">04/09/2000</p>		
Name and mailing address of the ISA European Patent Office, P.B. 5818 Patentlaan 2 NL - 2280 HV Rijswijk Tel. (+31-70) 340-2040, Tx. 31 651 epo nl, Fax: (+31-70) 340-3016		Authorized officer <p style="text-align: center; font-size: 1.2em;">Lenoir, C</p>		

INTERNATIONAL SEARCH REPORT

Information on patent family members

International Application No

PCT/EP 00/04518

Patent document cited in search report	Publication date	Patent family member(s)	Publication date
WO 9717259 A	15-05-1997	US 5765608 A	16-06-1998
		AU 1051097 A	29-05-1997
