



US009270953B2

(12) **United States Patent**  
**Wang et al.**

(10) **Patent No.:** **US 9,270,953 B2**  
(45) **Date of Patent:** **Feb. 23, 2016**

(54) **WAFER LEVEL CAMERA HAVING  
MOVABLE COLOR FILTER GROUPING**

(71) Applicant: **OMNIVISION TECHNOLOGIES,  
INC.**, Santa Clara, CA (US)

(72) Inventors: **Chia-Ching Wang**, Hsinchu (TW);  
**Jau-Jan Deng**, Taipei (TW);  
**Yun-Chiang Hsu**, Yangmei (TW)

(73) Assignee: **OmniVision Technologies, Inc.**, Santa  
Clara, CA (US)

(\* ) Notice: Subject to any disclaimer, the term of this  
patent is extended or adjusted under 35  
U.S.C. 154(b) by 1 day.

(21) Appl. No.: **14/279,744**

(22) Filed: **May 16, 2014**

(65) **Prior Publication Data**

US 2015/0334357 A1 Nov. 19, 2015

(51) **Int. Cl.**  
**H04N 9/04** (2006.01)  
**H04N 5/225** (2006.01)  
**H04N 5/369** (2011.01)

(52) **U.S. Cl.**  
CPC ..... **H04N 9/045** (2013.01); **H04N 5/2254**  
(2013.01); **H04N 5/369** (2013.01)

(58) **Field of Classification Search**  
CPC ..... H04N 9/045; H04N 5/2254; H04N 5/369  
USPC ..... 348/270, 271, 278, 222.1  
See application file for complete search history.

(56) **References Cited**

U.S. PATENT DOCUMENTS

5,153,717 A \* 10/1992 Nitta ..... 348/270  
5,475,428 A \* 12/1995 Hintz et al. .... 348/263

7,247,851 B2 7/2007 Okada et al.  
7,453,510 B2 11/2008 Kolehmainen et al.  
7,812,869 B2 10/2010 Boettiger  
9,071,721 B1 \* 6/2015 D'Amico et al.  
2002/0089596 A1 7/2002 Suda  
2006/0023314 A1 2/2006 Boettiger et al.  
2007/0008421 A1 1/2007 Wu et al.  
2007/0126898 A1 6/2007 Feldman et al.  
2008/0049126 A1 2/2008 Ford et al.  
2008/0128843 A1 6/2008 Lee  
2008/0142685 A1 6/2008 Gazeley  
2010/0065897 A1 3/2010 Jun  
2012/0104525 A1 5/2012 Wu et al.  
2013/0320195 A1 12/2013 Wang et al.  
2014/0043507 A1 2/2014 Wang et al.

FOREIGN PATENT DOCUMENTS

EP 2214405 A2 8/2010  
JP 03062667 A \* 3/1991 ..... H04N 1/04

\* cited by examiner

*Primary Examiner* — Nhan T Tran

(74) *Attorney, Agent, or Firm* — Blakely Sokolof Taylor &  
Zafman LLP

(57) **ABSTRACT**

An image capture unit includes an image sensor and a lens structure disposed proximate to the image sensor to focus an image onto the image sensor. A movable color filter grouping is disposed over the lens structure. The movable color filter grouping includes a plurality of N color filters arranged therein such that all light that is incident upon the image sensor through the lens structure is directed through only one of the plurality of N color filters of the movable color filter grouping per each exposure of the image sensor. A positioning device is attached to the movable color filter grouping to reposition the movable color filter grouping such that substantially all of the light that is incident upon the image sensor through the lens structure is directed through a different one of the plurality of N color filters for each successive exposure of the image sensor.

**18 Claims, 4 Drawing Sheets**

204

R1	R2	R3	R4	R5	R6
R7	R8	R9	R10	R11	R12
R13	R14	R15	R16	R17	R18
R19	R20	R21	R22	R23	R24

204

G1	G2	G3	G4	G5	G6
G7	G8	G9	G10	G11	G12
G13	G14	G15	G16	G17	G18
G19	G20	G21	G22	G23	G24

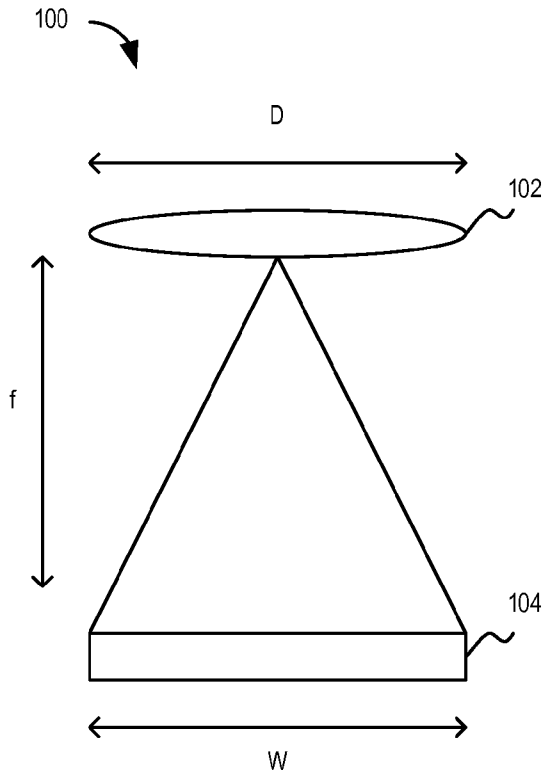

FIG. 1A

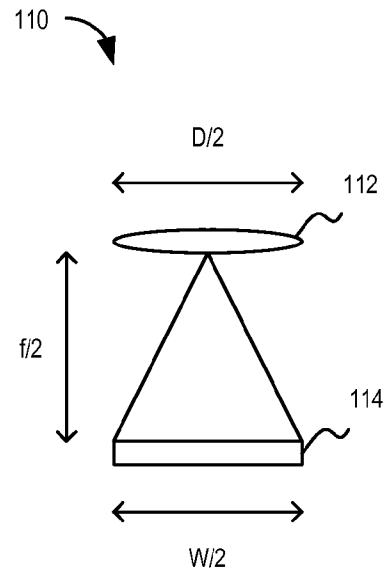

FIG. 1B

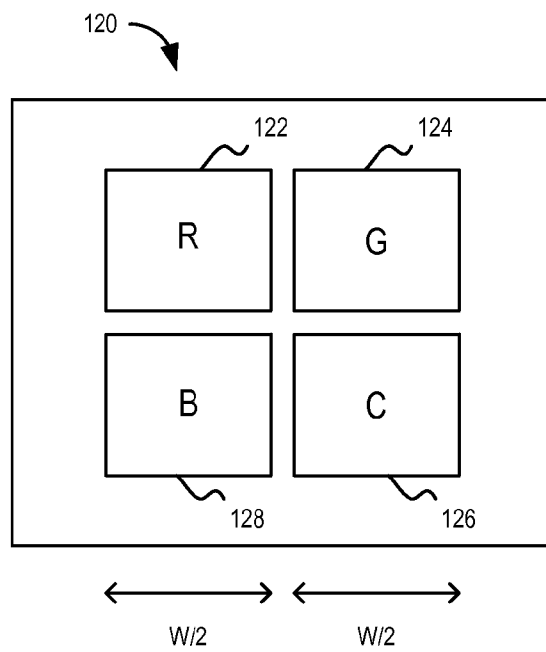

FIG. 1C

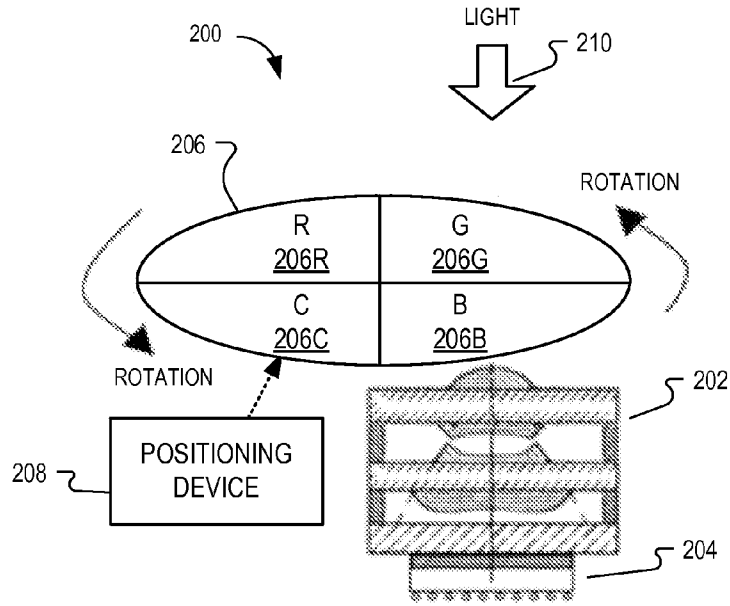

FIG. 2A

204

R1	R2	R3	R4	R5	R6
R7	R8	R9	R10	R11	R12
R13	R14	R15	R16	R17	R18
R19	R20	R21	R22	R23	R24

FIG. 2B

204

G1	G2	G3	G4	G5	G6
G7	G8	G9	G10	G11	G12
G13	G14	G15	G16	G17	G18
G19	G20	G21	G22	G23	G24

FIG. 2C

204

B1	B2	B3	B4	B5	B6
B7	B8	B9	B10	B11	B12
B13	B14	B15	B16	B17	B18
B19	B20	B21	B22	B23	B24

FIG. 2D

204

C1	C2	C3	C4	C5	C6
C7	C8	C9	C10	C11	C12
C13	C14	C15	C16	C17	C18
C19	C20	C21	C22	C23	C24

FIG. 2E

212

R1	G1	R2	G2	R3	G3	R4	G4	R5	G5	R6	G6
C1	B1	C2	B2	C3	B3	C4	B4	C5	B5	C6	B6
R7	G7	R8	G8	R9	G9	R10	G10	R11	G11	R12	G12
C7	B7	C8	B8	C9	B9	C10	B10	C11	B11	C12	B12
R13	G13	R14	G14	R15	G15	R16	G16	R17	G17	R18	G18
C13	B13	C14	B14	C15	B15	C16	B16	C17	B17	C18	B18
R19	G19	R20	G20	R21	G21	R22	G22	R23	G23	R24	G24
C19	B19	C20	B20	C21	B21	C22	B22	C23	B23	C24	B24

FIG. 2F

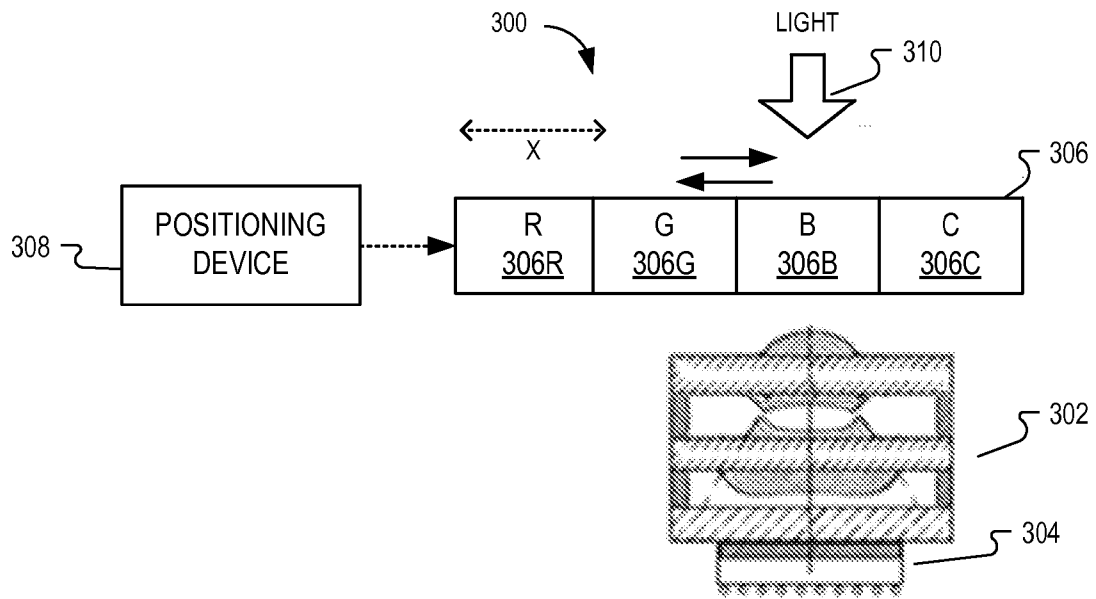

FIG. 3

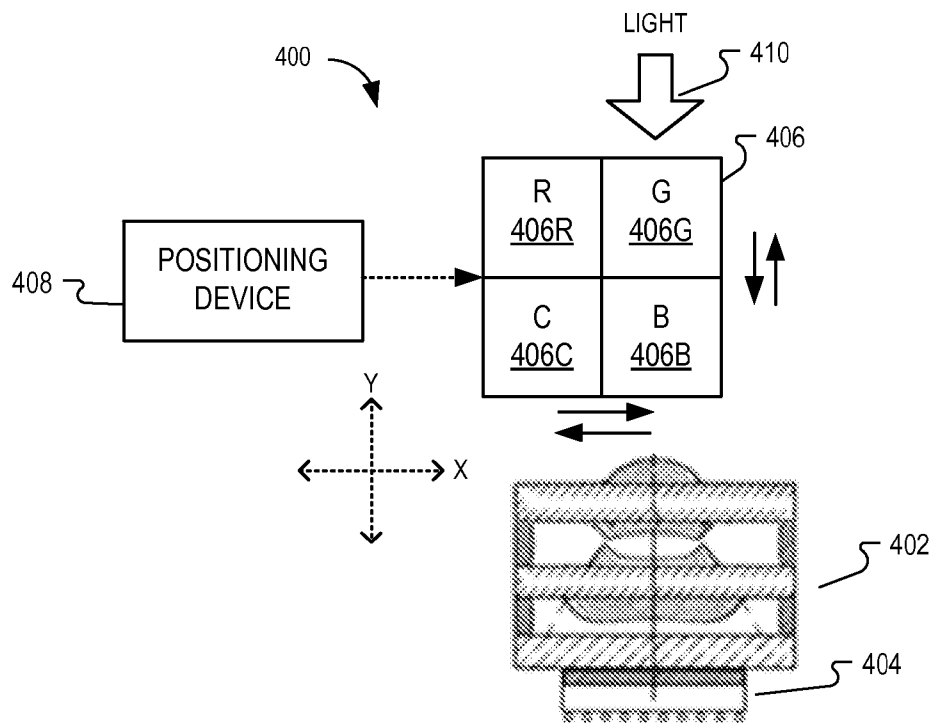

FIG. 4

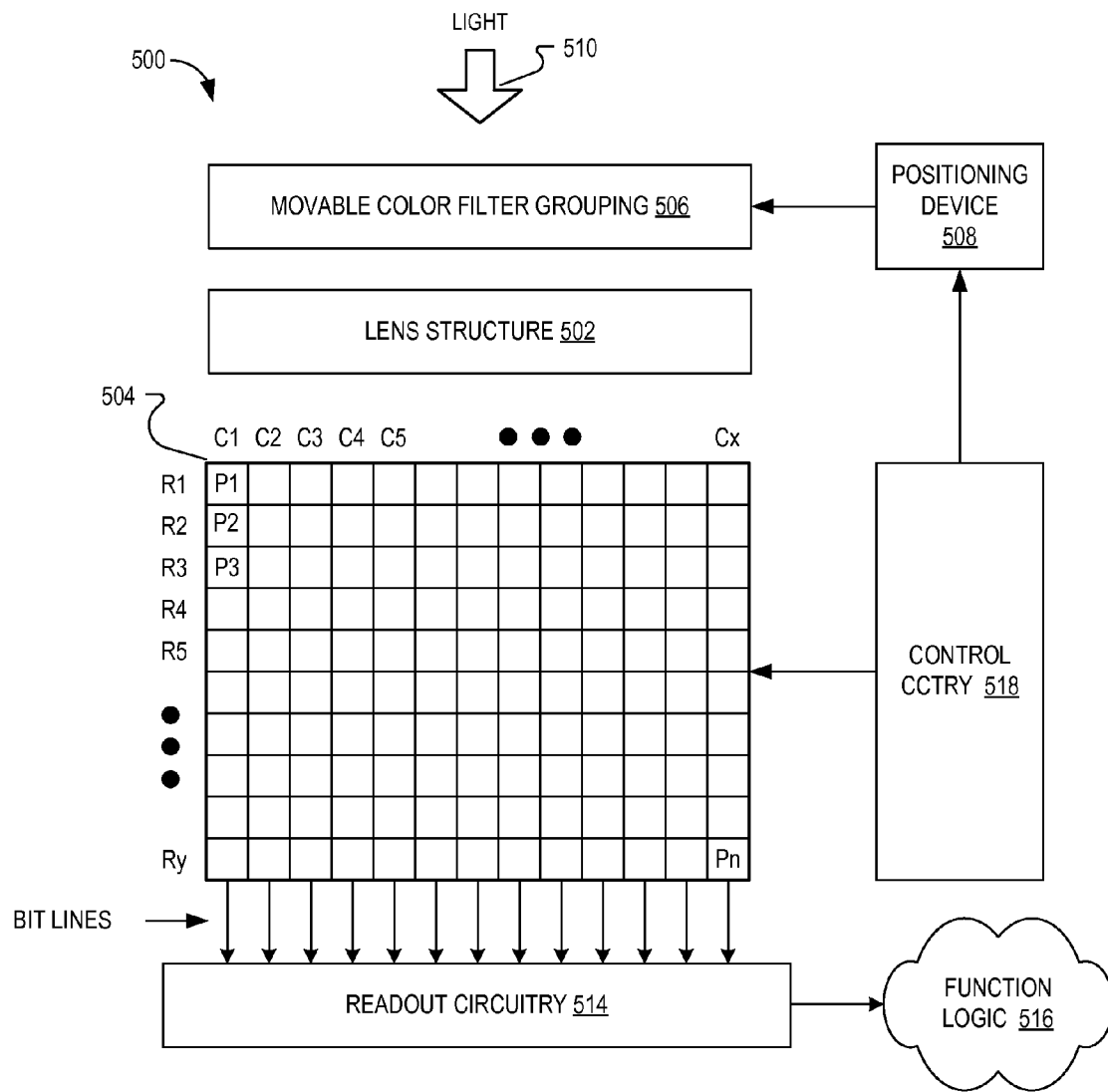

FIG. 5

1

## WAFFER LEVEL CAMERA HAVING MOVABLE COLOR FILTER GROUPING

### BACKGROUND INFORMATION

#### 1. Field of the Disclosure

The present invention relates generally to image sensors, and more specifically, to a color wafer level camera with a movable color filter grouping.

#### 2. Background

An image capture unit typically includes an image sensor and an imaging lens. The imaging lens focuses light onto the image sensor to form an image, and the image sensor converts the light into electric signals. The electric signals are output from the image capture unit to other units in a host electronic system or a subsystem. The electronic system may be a mobile phone, a computer, a digital camera or a medical device.

As the use of image capture units in electronic systems increases, so do the demands for image capture unit features, capabilities and device dimensions. For example, image capture units are increasingly required to have lower profiles so that overall sizes of electronic systems including the image capture units can be reduced while at the same time not sacrifice quality in the optical images that are captured. The profile of an image capture unit may be associated with the distance from the bottom of image sensor to the top of the imaging lens.

### BRIEF DESCRIPTION OF THE DRAWINGS

Non-limiting and non-exhaustive embodiments of the present invention are described with reference to the following figures, wherein like reference numerals refer to like parts throughout the various views unless otherwise specified.

FIG. 1A is a schematic diagram of an image capture unit including an imaging lens and an image sensor.

FIG. 1B is a schematic diagram of a low profile image capture unit including a low profile imaging lens and an image sensor.

FIG. 1C illustrates an image sensor having four partitioned areas with four low profile imaging lenses.

FIG. 2A shows one example of a low profile image capture unit that includes movable color filter grouping disposed over a single lens structure disposed proximate to an image sensor having a single partition in accordance with the teachings of the present invention.

FIG. 2B shows an example of pixel cell image data values in the pixel array of image sensor after an exposure of image sensor with all of the incident light directed through a first color filter of a movable color filter grouping and lens structure in accordance with the teachings of the present invention.

FIG. 2C shows an example of pixel cell image data values in the pixel array of image sensor after an exposure of image sensor with all of the incident light directed through a second color filter of a movable color filter grouping and lens structure in accordance with the teachings of the present invention.

FIG. 2D shows an example of pixel cell image data values in the pixel array of image sensor after an exposure of image sensor with all of the incident light directed through a third color filter of a movable color filter grouping and lens structure in accordance with the teachings of the present invention.

FIG. 2E shows an example of pixel cell image data values in the pixel array of image sensor after an exposure of image sensor with all of the incident light directed through a fourth color filter of a movable color filter grouping and lens structure in accordance with the teachings of the present invention.

2

FIG. 2F shows an example of pixel cell image data values in the pixel array of image sensor after an exposure of image sensor with all of the incident light directed through a fifth color filter of a movable color filter grouping and lens structure in accordance with the teachings of the present invention.

FIG. 3 shows another example of a low profile image capture unit that includes movable color filter grouping disposed over a single lens structure disposed proximate to an image sensor having a single partition in accordance with the teachings of the present invention.

FIG. 4 shows yet another example of a low profile image capture unit that includes movable color filter grouping disposed over a single lens structure disposed proximate to an image sensor having a single partition in accordance with the teachings of the present invention.

FIG. 5 is a block diagram illustrating an example image sensing system in accordance with the teachings of the present invention.

### DETAILED DESCRIPTION

In the following description, numerous specific details are set forth in order to provide a thorough understanding of the present invention. It will be apparent, however, to one having ordinary skill in the art that the specific detail need not be employed to practice the present invention. In other instances, well-known materials or methods have not been described in detail in order to avoid obscuring the present invention.

Reference throughout this specification to “one embodiment”, “an embodiment”, “one example” or “an example” means that a particular feature, structure or characteristic described in connection with the embodiment or example is included in at least one embodiment of the present invention. Thus, appearances of the phrases “in one embodiment”, “in an embodiment”, “one example” or “an example” in various places throughout this specification are not necessarily all referring to the same embodiment or example. Furthermore, the particular features, structures or characteristics may be combined in any suitable combinations and/or subcombinations in one or more embodiments or examples. Particular features, structures or characteristics may be included in an integrated circuit, an electronic circuit, a combinational logic circuit, or other suitable components that provide the described functionality. In addition, it is appreciated that the figures provided herewith are for explanation purposes to persons ordinarily skilled in the art and that the drawings are not necessarily drawn to scale.

Example methods and apparatuses directed to a low profile image capture unit are disclosed. As will be appreciated, a low profile image capture unit according to the teachings of the present invention may include a movable color filter grouping having a plurality of colors disposed over a single lens structure on a single image sensor. Furthermore, the quality of optical images captured, which may for example be express in terms of resolution (i.e., the number of pixels) and/or sharpness, is not sacrificed for the low profile in accordance with the teachings of the present invention.

To illustrate, FIG. 1A is a schematic diagram of an image capture unit **100** including an imaging lens **102** and an image sensor **104**. The distance between lens **102** and image sensor **104** is approximately  $f$ , where  $f$  is the focal length of lens **102**. The width of the image sensor **104** covered by lens **102** is  $W$ , and the lens diameter is  $D$ . For comparison, FIG. 1B shows a schematic diagram of a low profile image capture unit **110** including an imaging lens **112** and an image sensor **114**. The distance between lens **112** and image sensor **114** is approxi-

mately  $f/2$ , where  $f/2$  is the focal length of lens **112**. The width of the image sensor **114** covered by lens **112** is  $W/2$ , and the lens diameter is  $D/2$ .

In the low profile image capture unit **110** depicted in FIG. **1B**, the imaging lens **102** is replaced with a low profile imaging lens **112**, while the size of the image sensor is unchanged. In the example, image sensors **104** and **114** are the same image sensor, and both image sensors have the same pixel array structure. Since the width of image sensor **114** is half of the width of image sensor **104**, image sensor **114** will have half of number of pixels as compared with image sensor **104** in one dimension. In two dimensions, image sensor **114** will have quarter of number of pixels as compared with image sensor **104**. In other words, the number of pixels of the image captured is approximately proportional to the square of the scale of the distance between the lens and the image sensor.

FIG. **1C** illustrates an image sensor **120** having four partitioned areas **122**, **124**, **126**, and **128** closely arranged proximate to each other. Each partitioned area **122**, **124**, **126**, and **128** is covered by a respective imaging lens (e.g., lens **112** of FIG. **1B**). In this manner, the focal length of the imaging lens (e.g., lens **112** of FIG. **1B**) can be half of the imaging lens when the image sensor is not partitioned into four areas (e.g., lens **102** of FIG. **1A**). Thus, a low profile image capture unit can be constructed using four lenses and four partitioned areas of an image sensor. The low profile image capture unit **110** will have approximately the same resolution (i.e., the same number of pixels) as compared with the original image capture unit **100**, because four partitioned areas **122**, **124**, **126**, and **128** of the image sensor are used. However, in the example depicted in FIG. **1C**, image sensor **120** includes four imaging lenses (e.g., lens **112** of FIG. **1B**), with one imaging lens for each of the four partitioned areas **122**, **124**, **126**, and **128**. Consequently, as the number of partitions increases in the image sensor, the number of imaging lenses also increases.

FIG. **2A** shows one example of a low profile image capture unit that includes movable color filter grouping disposed over a single lens structure disposed proximate to an image sensor having a single partition in accordance with the teachings of the present invention. In the depicted example, it is appreciated that the example image capture unit illustrated in FIG. **2A** realizes the same low profile and the same resolution (i.e., the same number of pixels) as compared with the original image capture unit described above in FIG. **1A**, but with only a single lens structure and image sensor partition in accordance with the teachings of the present invention.

In particular, the example illustrated in FIG. **2A** shows a low profile image capture unit **200** including an image sensor **204** with a lens structure **202** disposed proximate to the image sensor **204** to focus an image onto the image sensor **204**. In the example, image sensor **204** is a single partition that includes a pixel array having a plurality of pixel cells arranged therein. As shown, a movable color filter grouping **206** is disposed over the lens structure **202**. The movable color filter grouping **206** includes a plurality of  $N$  color filters arranged therein. In the example depicted in FIG. **2A**,  $N=4$  and the four color filters arranged in movable color filter grouping **206** include a red color filter **206R**, a green color filter **206G**, a blue color filter **206B**, and a clear color filter **206C**. It is appreciated of course that the red, green, blue, and clear color filters are provided in the illustrated example for explanation purposes only, and that other different combinations of color filters may also be provided in accordance with the teachings of the present invention.

The example depicted in FIG. **2A** shows that low profile image capture unit **200** also includes a positioning device

**208**, which is attached to the movable color filter grouping **206** to reposition the movable color filter grouping **206** between each exposure of the image sensor **204**. In one example, and as depicted in FIG. **2A**, movable color filter grouping **206** may include an RGB color wheel and positioning device **208** includes a motor attached to the movable color filter grouping **206** to rotate the movable color filter grouping **206** with respect to the lens structure **202** and the image sensor **204** between each successive exposure of image sensor **204**. As such, substantially all of the light **210** that is incident upon the image sensor **204** through the lens structure **202** is directed through a different one of the plurality of  $N$  color filters **206R**, **206G**, **206B**, or **206C** for each successive exposure of the image sensor **204** in accordance with the teachings of the present invention. In one example,  $N$  successive exposures of the image sensor **204** are coupled to be combined into a single color image in accordance with the teachings of the present invention.

To illustrate, FIG. **2B** shows an example of pixel cell image data values in the pixel array of image sensor **204** after an exposure of image sensor **204** with all of the incident light **210** directed through red color filter **206R** of movable color filter grouping **206** and lens structure **202** in accordance with the teachings of the present invention. As shown, all of the pixel cell image data values represent red image data values  $R_1, R_2, \dots, R_{24}$ . It is appreciated of course that although image sensor **204** is illustrated as including only 24 image data values  $R_1, R_2, \dots, R_{24}$  in FIG. **2B** for explanation purposes, the pixel array of image sensor **204** may include a different number of pixel cells in accordance with the teachings of the present invention.

Continuing with the example described in FIG. **2B**, after the exposure of image sensor **204** with substantially all of the light **210** directed through red color filter **206R** as shown, positioning device **208** may then re-position movable color filter grouping **206** such that for the next successive exposure, substantially all of the light **210** that is incident on image sensor **204** is directed through green color filter **206G** of movable color filter grouping **206** in accordance with the teachings of the present invention.

Accordingly, FIG. **2C** shows an example of pixel cell image data values in the pixel array of image sensor **204** after an exposure of image sensor **204** with all of the incident light **210** directed through green color filter **206G** of movable color filter grouping **206** and lens structure **202** in accordance with the teachings of the present invention. As shown, all of the pixel cell image data values represent green image data values  $G_1, G_2, \dots, G_{24}$ .

Continuing with the example described in FIG. **2C**, after the exposure of image sensor **204** with substantially all of the light **210** directed through green color filter **206G** as shown, positioning device **208** may then re-position movable color filter grouping **206** such that for the next successive exposure, substantially all of the light **210** that is incident on image sensor **204** is directed through blue color filter **206B** of movable color filter grouping **206** in accordance with the teachings of the present invention.

Accordingly, FIG. **2D** shows an example of pixel cell image data values in the pixel array of image sensor **204** after an exposure of image sensor **204** with all of the incident light **210** directed through blue color filter **206B** of movable color filter grouping **206** and lens structure **202** in accordance with the teachings of the present invention. As shown, all of the pixel cell image data values represent blue image data values  $B_1, B_2, \dots, B_{24}$ .

Continuing with the example described in FIG. **2D**, after the exposure of image sensor **204** with substantially all of the

5

light **210** directed through blue color filter **206B** as shown, positioning device **208** may then re-position movable color filter grouping **206** such that for the next successive exposure, substantially all of the light **210** that is incident on image sensor **204** is directed through clear color filter **206C** of movable color filter grouping **206** in accordance with the teachings of the present invention.

Accordingly, FIG. 2E shows an example of pixel cell image data values in the pixel array of image sensor **204** after an exposure of image sensor **204** with all of the incident light **210** directed through clear color filter **206C** of movable color filter grouping **206** and lens structure **202** in accordance with the teachings of the present invention. As shown, all of the pixel cell image data values represent clear image data values C1, C2, . . . , C24.

FIG. 2F illustrates that in one example, after the N successive exposures of image sensor **204** through each of the different N color filters of movable color filter grouping **206**, the image data from the N successive exposures of the image sensor **204**, such as for example as illustrated above in FIGS. 2B-2E, are coupled to be combined into a single color image **212** in accordance with the teachings of the present invention. In particular, in the example depicted in FIG. 2E, the red, green, blue, and clear image channels are combined 4 to 1 into single color image **212** by re-arranging the order as shown in accordance with the teachings of the present invention.

Accordingly, a high resolution color image **212** may be realized using low profile image capture unit **200** using only a single lens structure **202** and image sensor **204** partition with movable color filter grouping **206** in accordance with the teachings of the present invention. As such, low profile image capture unit **200** only needs a single lens structure instead of an array of lens structures, compared to for example image sensor **120**, as described above in FIG. 1C. Since only one lens structure **202** is needed, overall lens performance may be improved, and overall volume and cost and cost savings may be realized, since only one lens structure is needed instead of an array of lens structures for each image capture unit in accordance with the teachings of the present invention.

FIG. 3 shows another example of a low profile image capture unit **300** that includes movable color filter grouping disposed over a single lens structure disposed proximate to an image sensor having a single partition in accordance with the teachings of the present invention. In the depicted example, it is appreciated that the example image capture unit illustrated in FIG. 3 also realizes the same low profile and the same resolution (i.e., the same number of pixels) as compared with the original image capture unit described above in FIG. 1A, but with only a single lens structure and image sensor partition in accordance with the teachings of the present invention.

In particular, the example low profile image capture unit **300** depicted in FIG. 3 includes an image sensor **304** with a lens structure **302** disposed proximate to the image sensor **304** to focus an image onto the image sensor **304**. In the example, image sensor **304** is a single partition that includes a pixel array having a plurality of pixel cells arranged therein. As shown, a movable color filter grouping **306** is disposed over the lens structure **302**. The movable color filter grouping **306** includes a plurality of N color filters arranged therein. In the example depicted in FIG. 3, N=4 and the four color filters arranged in movable color filter grouping **306** include a red color filter **306R**, a green color filter **306G**, a blue color filter **306B**, and a clear color filter **306C**.

The example depicted in FIG. 3 shows that low profile image capture unit **300** also includes a positioning device **308**, which is attached to the movable color filter grouping **306** to reposition the movable color filter grouping **306**

6

between each exposure of the image sensor **304**. In one example, and as depicted in FIG. 3, movable color filter grouping **306** may include an RGBC color guide, which in the illustrated example includes red color filter **306R**, a green color filter **306G**, a blue color filter **306B**, and a clear color filter **306C** arranged along one direction, such as for example along the x-axis, as shown.

In one example, positioning device **308** includes an actuator attached to the movable color filter grouping **306** to shift the movable color filter grouping **306**, such as for example along the x-axis, with respect to the lens structure **302** and the image sensor **304** between each successive exposure of image sensor **304**. For instance, in one example the actuator of positioning device **308** includes a voice coil module actuator attached to the movable color filter grouping **306**. In another example, the actuator includes a piezo actuator attached to the movable color filter grouping **306**. In still another example, the actuator includes a micro-electro-mechanical system (MEMS) actuator attached to the movable color filter grouping **306**. In various examples, a frequency of the actuator of positioning device **308** is greater than a frame rate of the image sensor **304**. In various examples, a moving speed of the actuator of positioning device **308** is greater than a shutter speed of the image sensor **304**.

Continuing with the example depicted in FIG. 3, substantially all of the light **310** that is incident upon the image sensor **304** through the lens structure **302** is directed through a different one of the plurality of N color filters **306R**, **306G**, **306B**, or **306C** for each successive exposure of the image sensor **304** in accordance with the teachings of the present invention. In one example, N successive exposures of the image sensor **304** are coupled to be combined into a single color image, in a similar fashion as described in the example above in FIGS. 2B-2E in accordance with the teachings of the present invention. In one example, the positioning device **308** cycles through all of the plurality of N color filters of movable color filter grouping **306** after the N successive exposures of image sensor **304** in accordance with the teachings of the present invention.

FIG. 4 shows yet another example of a low profile image capture unit **400** that includes movable color filter grouping disposed over a single lens structure disposed proximate to an image sensor having a single partition in accordance with the teachings of the present invention. In the depicted example, it is appreciated that the example image capture unit illustrated in FIG. 4 also realizes the same low profile and the same resolution (i.e., the same number of pixels) as compared with the original image capture unit described above in FIG. 1A, but with only a single lens structure and image sensor partition in accordance with the teachings of the present invention.

In particular, the example low profile image capture unit **400** illustrated in FIG. 4 includes an image sensor **404** with a lens structure **402** disposed proximate to the image sensor **404** to focus an image onto the image sensor **404**. In the example, image sensor **404** is a single partition that includes a pixel array having a plurality of pixel cells arranged therein. As shown, a movable color filter grouping **406** is disposed over the lens structure **402**. The movable color filter grouping **406** includes a plurality of N color filters arranged therein. In the example depicted in FIG. 4, N=4 and the four color filters arranged in movable color filter grouping **406** include a red color filter **406R**, a green color filter **406G**, a blue color filter **406B**, and a clear color filter **406C**.

The example depicted in FIG. 4 shows that low profile image capture unit **400** also includes a positioning device **408**, which is attached to the movable color filter grouping **406** to reposition the movable color filter grouping **406**

between each exposure of the image sensor **404**. In one example, and as depicted in FIG. **4**, movable color filter grouping **406** may include an RGB color square, which in the illustrated example includes red color filter **406R**, a green color filter **406G**, a blue color filter **406B**, and a clear color filter **406C** arranged along two directions, such as for example along the x-axis, and along the y-axis as shown.

In one example, positioning device **408** includes an actuator attached to the movable color filter grouping **306** to shift the movable color filter grouping **406**, such as for example along the x-axis, or along the y-axis, with respect to the lens structure **402** and the image sensor **404** between each successive exposure of image sensor **404**. For instance, in one example the actuator of positioning device **408** includes a voice coil module actuator attached to the movable color filter grouping **406**. In another example, the actuator includes a piezo actuator attached to the movable color filter grouping **406**. In still another example, the actuator includes a micro-electro-mechanical system (MEMS) actuator attached to the movable color filter grouping **306**. In various examples, a frequency of the actuator of positioning device **408** is greater than a frame rate of the image sensor **404**. In various examples, a moving speed of the actuator of positioning device **308** is greater than a shutter speed of the image sensor **404**.

Continuing with the example depicted in FIG. **4**, substantially all of the light **410** that is incident upon the image sensor **404** through the lens structure **402** is directed through a different one of the plurality of N color filters **406R**, **406G**, **406B**, or **406C** for each successive exposure of the image sensor **404** in accordance with the teachings of the present invention. In one example, N successive exposures of the image sensor **404** are coupled to be combined into a single color image, in a similar fashion as described in the example above in FIGS. 2B-2E in accordance with the teachings of the present invention. In one example, the positioning device **408** cycles through all of the plurality of N color filters of movable color filter grouping **406** after N successive exposures of image sensor **404** in accordance with the teachings of the present invention.

FIG. **5** is a block diagram illustrating an example image sensing system **500** in accordance with the teachings of the present invention. In one example, image sensing system **500** may be an example of low profile image capture unit **200** of FIG. 2A, or of low profile image capture unit **300** of FIG. 3, or of low profile image capture unit **400** of FIG. 4 in accordance with the teachings of the present invention. Accordingly, it is noted that that similarly named and numbered elements referenced below are coupled and function similar to as described above. In the example depicted in FIG. **5**, image sensing system **500** includes an image sensor **504**, readout circuitry **514**, function logic **516**, and control circuitry **518**. In one example, image sensing system **500** further includes a lens structure **502** disposed proximate to the image sensor **504** to focus an image onto the image sensor **504**, a movable color filter grouping **506** disposed over the lens structure **502**, and a positioning device **508** attached to the movable color filter grouping **506** to reposition a plurality of N color filters included in movable color filter grouping **506** between each exposure of the image sensor **504**. In one example, substantially all of the light **510** that is incident upon the image sensor **504** through the lens structure **502** is directed through a different one of the plurality of N color filters of movable color filter grouping **506** for each successive exposure of the image sensor **504** in accordance with the teachings of the present invention. In one example, N successive exposures of the image sensor **504** are coupled to be combined into a single

color image in accordance with the teachings of the present invention. In one example, control circuitry **518** is coupled to the image sensor **504** to control operation of the image sensor **504**. In one example, control circuitry **518** is further coupled to the positioning device **508** to control the repositioning of the N plurality of color filters of movable color filter grouping **506** as discussed above in accordance with the teachings of the present invention.

In one example, as shown in the example depicted in FIG. **5**, image sensor **504** includes a two-dimensional (2D) pixel array having a plurality of pixel cells (e.g., P1, P2, . . . Pn) arranged therein. Each pixel cell may be a CMOS pixel or a CCD pixel. As illustrated, each pixel cell is arranged into a row (e.g., rows R1 to Ry) and a column (e.g., column C1 to Cx) to acquire image data of a person, place, object, etc., which can then be used to render a 2D image of the person, place, object, etc. In one example, image sensor **504** is a backside illuminated (BSI) image sensor. In one example, image sensor **504** is a frontside illuminated (FSI) image sensor. In the depicted example image sensor **504** is a single partition and is covered by lens structure **502** and movable color filter grouping **506** as discussed above in accordance with the teachings of the present invention.

After each successive exposure of image sensor **504** after which each pixel cell has acquired its image data or image charge, the image data is readout by readout circuitry **514** and transferred to function logic **516**. Readout circuitry **514** may include amplification circuitry, analog-to-digital (ADC) conversion circuitry, or otherwise. Function logic **516** may simply store the image data or even manipulate the image data by applying post image effects (e.g., crop, rotate, remove red eye, adjust brightness, adjust contrast, or otherwise). In one example, the function logic **516** is coupled to the readout circuitry **514** to combine the N successive exposures of the image sensor **504** into a single color image, as discussed above in accordance with the teachings of the present invention. In one example, readout circuitry **514** may readout a row of image data at a time along readout column lines (illustrated) or may readout the image data using a variety of other techniques (not illustrated), such as a serial readout or a full parallel readout of all pixels simultaneously.

Control circuitry **518** is coupled to image sensor **504** to control operational characteristic of image sensor **504**. For example, control circuitry **518** may generate a shutter signal for controlling image acquisition. In one example, the shutter signal is a global shutter signal for simultaneously enabling all pixels within image sensor **504** to simultaneously capture their respective image data during a single acquisition window. In another example, the shutter signal is a rolling shutter signal whereby each row, column, or group of pixels is sequentially enabled during consecutive acquisition windows.

The above description of illustrated examples of the present invention, including what is described in the Abstract, are not intended to be exhaustive or to be limitation to the precise forms disclosed. While specific embodiments of, and examples for, the invention are described herein for illustrative purposes, various equivalent modifications are possible without departing from the broader spirit and scope of the present invention. Indeed, it is appreciated that the specific example voltages, currents, frequencies, power range values, times, etc., are provided for explanation purposes and that other values may also be employed in other embodiments and examples in accordance with the teachings of the present invention.

What is claimed is:

1. An image capture unit, comprising:
  - an image sensor including a pixel array having M pixels;
  - a lens structure disposed proximate to the image sensor to focus an image onto the image sensor;
  - a movable color filter grouping disposed over the lens structure, wherein the movable color filter grouping includes a plurality of N color filters arranged therein such that all light that is incident upon the image sensor through the lens structure is directed through only one of the plurality of N color filters of the movable color filter grouping per each exposure of the image sensor;
  - a positioning device attached to the movable color filter grouping to reposition the movable color filter grouping between each exposure of the image sensor such that substantially all of the light that is incident upon the image sensor through the lens structure is directed through a different one of the plurality of N color filters for each successive exposure of the image sensor; and
  - circuitry and logic coupled to the image sensor to:
    - capture N single-color images each with M pixel resolution, and
    - combine the N single-color images into one multi-color image with substantially MxN pixel resolution.
2. The image capture unit of claim 1 wherein the plurality of N color filters includes a red filter, a green filter, a blue filter, and a clear filter.
3. The image capture unit of claim 1 wherein the positioning device includes a motor attached to the movable color filter grouping to rotate the movable color filter grouping with respect to the lens structure and the image sensor.
4. The image capture unit of claim 1 wherein the positioning device includes an actuator attached to the movable color filter grouping to shift the movable color filter grouping along an x direction with respect to the lens structure and the image sensor.
5. The image capture unit of claim 4 wherein the actuator attached to the movable color filter grouping is further coupled to shift the movable color filter grouping along a y direction with respect to the lens structure and the image sensor.
6. The image capture unit of claim 4 wherein the actuator comprises a voice coil module actuator attached to the movable color filter grouping.
7. The image capture unit of claim 4 wherein the actuator comprises a piezo actuator attached to the movable color filter grouping.
8. The image capture unit of claim 4 wherein the actuator comprises a micro-electro-mechanical system (MEMS) actuator attached to the movable color filter grouping.
9. The image capture unit of claim 4 wherein a frequency of the actuator attached to the movable color filter grouping is greater than a frame rate of the image sensor.
10. The image capture unit of claim 4 wherein a moving speed of the actuator attached to the movable color filter grouping is greater than a shutter speed of the image sensor.

11. An imaging system, comprising:
  - an image sensor including a pixel array;
  - a lens structure disposed proximate to the image sensor to focus an image onto the image sensor;
  - a movable color filter grouping disposed over the lens structure, wherein the movable color filter grouping includes a plurality of N color filters arranged therein such that all light that is incident upon the image sensor through the lens structure is directed through only one of the plurality of N color filters of the movable color filter grouping per each exposure of the image sensor;
  - a positioning device attached to the movable color filter grouping to reposition the movable color filter grouping between each exposure of the image sensor such that substantially all of the light that is incident upon the image sensor through the lens structure is directed through a different one of the plurality of N color filters for each successive exposure of the image sensor;
  - control circuitry coupled to the pixel array to control operation of the pixel array, the control circuitry further coupled to the positioning device to control the repositioning of the movable color filter grouping;
  - readout circuitry coupled to the image sensor to readout image data from the plurality of pixels; and
  - function logic coupled to the readout circuitry to store the image data;
  - wherein the function logic is coupled to the readout circuitry to combine N successive single-color exposures into a single multi-color image by re-arranging the pixel order of each of the N successive single-color exposures; and
  - wherein number of pixels in the multi-color image is substantially N times the number of pixels in each of the single-color exposures.
12. The imaging system of claim 11 wherein the plurality of N color filters includes a red filter, a green filter, a blue filter, and a clear filter.
13. The imaging system of claim 11 wherein the positioning device includes a motor attached to the movable color filter grouping to rotate the movable color filter grouping with respect to the lens structure and the image sensor.
14. The imaging system of claim 11 wherein the positioning device includes an actuator attached to the movable color filter grouping to shift the movable color filter grouping along an x direction with respect to the lens structure and the image sensor.
15. The imaging system of claim 14 wherein the actuator attached to the movable color filter grouping is further coupled to shift the movable color filter grouping along a y direction with respect to the lens structure and the image sensor.
16. The imaging system of claim 14 wherein the actuator comprises a voice coil module actuator attached to the movable color filter grouping.
17. The imaging system of claim 14 wherein the actuator comprises a piezo actuator attached to the movable color filter grouping.
18. The imaging system of claim 14 wherein the actuator comprises a micro-electro-mechanical system (MEMS) actuator attached to the movable color filter grouping.

\* \* \* \* \*