

(19) World Intellectual Property Organization
International Bureau



(43) International Publication Date
24 January 2008 (24.01.2008)

PCT

(10) International Publication Number
WO 2008/010091 A2

- (51) International Patent Classification: **Not classified**
- (21) International Application Number: PCT/IB2007/002869
- (22) International Filing Date: 12 July 2007 (12.07.2007)
- (25) Filing Language: English
- (26) Publication Language: English
- (30) Priority Data: 60/830,104 12 July 2006 (12.07.2006) US
- (71) Applicant (for all designated States except US): **PHILIP MORRIS PRODUCTS S.A.** [CH/CH]; Quai Jeanrenaud 3, CH-2000 Neuchâtel (CH).
- (72) Inventors: **BRAUNSHTEYN, Michael**; 2018 Monument Avenue, Richmond, VA 23220 (US). **DWYER, Rowland, W.**; 400 Ziontown Road, Richmond, VA 23229 (US). **LI, San**; 1313 Goswick Ridge Road, Midlothian, VA 23114 (US). **OLEGARIO, Raquel**; 8221 W. Bon View Drive, Richmond, VA 23235 (US). **YOSS, Gail**; 6150 Cedar Springs Road, Chesterfield, VA 23832 (US).
- (74) Agent: **MARLOW, Nicholas, Simon**; Reddie & Grose, 16 Theobalds Road, London WC1X 8PL (GB).
- (81) Designated States (unless otherwise indicated, for every kind of national protection available): AE, AG, AL, AM, AT, AU, AZ, BA, BB, BG, BH, BR, BW, BY, BZ, CA, CH, CN, CO, CR, CU, CZ, DE, DK, DM, DO, DZ, EC, EE, EG, ES, FI, GB, GD, GE, GH, GM, GT, HN, HR, HU, ID, IL, IN, IS, JP, KE, KG, KM, KN, KP, KR, KZ, LA, LC, LK, LR, LS, LT, LU, LY, MA, MD, ME, MG, MK, MN, MW, MX, MY, MZ, NA, NG, NI, NO, NZ, OM, PG, PH, PL, PT, RO, RS, RU, SC, SD, SE, SG, SK, SL, SM, SV, SY, TJ, TM, TN, TR, TT, TZ, UA, UG, US, UZ, VC, VN, ZA, ZM, ZW.
- (84) Designated States (unless otherwise indicated, for every kind of regional protection available): ARIPO (BW, GH, GM, KE, LS, MW, MZ, NA, SD, SL, SZ, TZ, UG, ZM, ZW), Eurasian (AM, AZ, BY, KG, KZ, MD, RU, TJ, TM), European (AT, BE, BG, CH, CY, CZ, DE, DK, EE, ES, FI, FR, GB, GR, HU, IE, IS, IT, LT, LU, LV, MC, MT, NL, PL, PT, RO, SE, SI, SK, TR), OAPI (BF, BJ, CF, CG, CI, CM, GA, GN, GQ, GW, ML, MR, NE, SN, TD, TG).
- Published:**
— without international search report and to be republished upon receipt of that report
- For two-letter codes and other abbreviations, refer to the "Guidance Notes on Codes and Abbreviations" appearing at the beginning of each regular issue of the PCT Gazette.

(54) Title: SMOKING ARTICLE WITH PLATE IMPACTOR

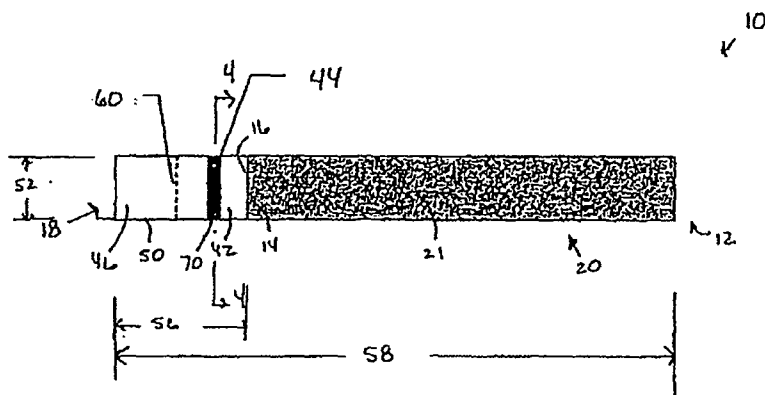

(57) Abstract: A smoking article (10) includes a filter system having an upstream plug (42) of filtering material, an impaction filter (44) and a downstream plug 46 of filtering material. The impaction filter includes at least one plate (70) having at least one orifice.

WO 2008/010091 A2

SMOKING ARTICLE WITH PLATE IMPACTOR

CROSS REFERENCE TO RELATED APPLICATION

This application claims priority from U.S. provisional Application No. 60/830,104, filed on July 12, 2006, the entire content of which is incorporated herein by reference.

BACKGROUND

Cigarettes are typically categorized according to their delivery of tar (nicotine free, dry particulate matter) under standard test procedures such as the one established in 1967 by the Federal Trade Commission (FTC). The FTC method includes machine drawn puffs at 35cm³ volume for 2-second duration each, at 60-second intervals. The International Organization for Standardization (ISO) has a similar smoking protocol.

In the 1990s, additional smoking protocols were proposed, including that of the Massachusetts Department of Public Health (MDPH), one of the so-called intense smoking regimes. The MDPH method includes machine drawn puffs at 45cm³ volume for 2-second duration each, at 30-second intervals, with 50% of the cigarette filter ventilation holes blocked.

It has been found that commercial lit-end cigarettes tend to produce higher tar than FTC deliveries when puff draw volume, frequency of draw and/or puff duration are increased and/or ventilation holes are occluded in whole or in part. This tendency is reflected, for example, in differences in measurement of tar (FTC) and tar (MDPH) with tar (MDPH) being representative of a more intense drawing condition over that of the former.

BRIEF DESCRIPTION OF THE DRAWINGS

FIG. 1 is a perspective view of a smoking article in the form of a cigarette.

FIG. 2 is a cross sectional view of the smoking article of FIG. 1 with at least one impaction plate.

FIG. 3 is a cross sectional view of another embodiment of the smoking article of FIG. 1 with at least one impaction plate and a plug of filtering material having an activated carbon material.

FIG. 4 is a view along the line 4-4 of FIGS. 2 and 3.

FIG. 5 is a side view of the at least one impaction plate of the smoking article of FIGS. 2 and 3.

FIG. 6 is a cross sectional view according to a further embodiment of a smoking article having at least one impaction plate.

FIG. 7 is a view along the line 7-7 of FIG. 6.

FIG. 8 is a view along the line 8-8 of FIG. 6.

FIG. 9 is a cross sectional view of another embodiment of a smoking article having at least one impaction plate.

FIG. 10 is a cross sectional view of a further embodiment of a smoking article having at least one impaction plate.

FIG. 11 is a cross sectional view of another embodiment of a smoking article having at least one impaction plate.

FIG. 12 is a cross sectional view of a further embodiment of a smoking article having at least one impaction plate.

FIG. 13 is a view along the line 13-13 of FIG. 12.

FIG. 14 is a view along the line 14-14 of FIG. 12.

FIG. 15 is a cross sectional view of another embodiment of a smoking article having at least one impaction plate.

FIG. 16 is a cross sectional view of a further embodiment of a smoking article having at least one impaction plate.

FIG. 17 is a view along the line 17-17 of FIG. 16.

FIG. 18 is a view along the line 18-18 of FIG. 16.

DETAILED DESCRIPTION

FIG. 1 shows a smoking article 10 in the form of a cigarette according to one embodiment, wherein the smoking article 10 reduces the ratio of total particulate matter (TPM) and tar yield by incorporating a filter system 40 into the cigarette or smoking article 10 that becomes more efficient at removing tar at larger puff volumes. The ratio of total particulate matter (TPM) and tar yield between MDPH and FTC/ISO methods for a given test cigarette is referenced herein as the "delivery elasticity".

Referring to FIGS. 1 and 2, smoking articles 10 in the form of cigarettes typically include a tobacco rod 20 of smoking material 21, contained in a circumscribing outer wrapper 30. The outer wrapper 30 is typically a porous wrapping material or paper wrapper. The smoking material 21 is preferably a shredded tobacco or tobacco cut filler. However, any suitable smoking material 21 can be used.

The smoking article 10 also includes a filter system 40 adjacent to the mouth end 14 of the tobacco rod 20 such that the filter system 40 and tobacco rod 20 are axially aligned in an end-to-end relationship, preferably abutting one another. The filter system 40 has a generally cylindrical shape, and the diameter thereof is essentially equal to the diameter of the tobacco rod 20. The ends (i.e., upstream end 16 (FIG. 2) and downstream end 18) of the filter system 40 are open to permit the passage of air and smoke therethrough. The filter system 40 includes a plurality of plugs 42, 46 (FIG. 2) of filtering material and an impaction filter 44 (FIG. 2) circumscribed by a plug wrap 48. The plug wrap 48 is typically a paper, which optionally

incorporates a carbonaceous material. The plug wrap 48 circumscribes the total length of the filter system 40.

The filter system 40 attaches to the tobacco rod 20 by a tipping material 50, which circumscribes both the entire length of the filter system 40 and an adjacent region of the tobacco rod 20. The tipping material 50 is typically a paper like product; however, any suitable material can be used. The inner surface of the tipping material 50 is fixedly secured to the outer surface of the plug wrap 48 and the outer surface of the wrapping material 30 of the tobacco rod 20, using a suitable adhesive. A ventilated or air diluted smoking article 10 can be provided with an air dilution means, such as a series of ventilation holes or perforations 60, each of which extends through the tipping material 50 and optionally the plug wrap 48. As shown in FIG. 1, ventilation of mainstream smoke can be achieved with a circumferential row (FIG. 1) or rows of ventilation holes or perforations 60 about a location along the filter system 40.

Upon lighting of the smoking article 10, the mainstream smoke is generated by and drawn from the tobacco rod 20 and through the filter system 40. Herein, the "upstream" and "downstream" relative positions between the filter system 40 and other features are described in relation to the direction of mainstream smoke as it is drawn from the tobacco rod 20 and through the filter system 40.

FIG. 2 shows a cross sectional view of the cigarette of FIG. 1 according to one embodiment of a smoking article 10 with the impaction filter 44 having at least one impaction plate 70. As shown in FIG. 2, the filter system 40 is comprised of a first or upstream plug 42 of filtering material, an impaction filter 44 and a second or downstream plug 46 of filtering material. The impaction filter 44 comprises a first or upstream impaction plate 70 having at least one orifice 72 (FIG. 4) and more preferably at least two orifices 72.

As shown in FIG. 2, the upstream plug 42 of filtering material and the downstream plug 46 of filtering material have a generally cylindrical shape, and an outer diameter 52 thereof that is essentially equal to the diameter of the tobacco rod 20. The filtering material is preferably cellulose acetate. However, it can be appreciated that the filtering material can be comprised of cellulose acetate with an activated carbon mixed throughout (often referred to as carbon-on-tow) or any other suitable filtering material and/or additives such as flavorants. The filter system 40 typically has an overall length 56 of about 15 to 40 mm for a smoking article 10 having an overall length 58 of about 80 to 160 mm. The filter system 40 also can include a plurality of ventilation holes or perforations 60 on either the downstream and/or upstream side of the impaction filter 44. In use, the filter system 40 incorporating the at least one impaction plate 70 into the cigarette or smoking article 10, minimizes the ratio of total particulate matter (TPM) and tar yield by increasing the filtration efficiency for particulates (tar) with the increase of flow rate or puff volume. Specifically, the range of TPM or tar that the smoker is exposed to, by increasing puff volume, is reduced due to the reduction in smoking elasticity.

FIG. 3 shows a cross sectional view of another embodiment of the smoking article 10 with at least one impaction plate 70 and an upstream plug 42 of carbon-on-tow 45. As shown in FIG. 3, the filter system 40 is comprised of an upstream plug 42 of filtering material with a cellulose acetate element mixed with an activated carbon material throughout in the form of a carbon-on-tow 45 plug of filtering material. It can also be appreciated that the plugs 42, 46 of filtering material can contain activated carbon in a cavity provided within or adjacent the upstream and downstream plugs 42, 46 of cellulose acetate material. Alternatively, the upstream and downstream plugs 42, 46 of filtering material can contain activated carbon or other gas-vapor phase sorbents.

FIG. 4 shows a cross sectional view of the at least one impaction plate 70 of the smoking article 10 of FIGS. 2 and 3 along the line 4-4. As shown in FIG. 4, the impaction filter 44 comprises an impaction plate 70 having a plurality of orifices 72. The impaction plate 70 preferably has a diameter 110 of about 7.0mm to 8.0mm and more preferably about 7.4mm to 7.8mm. The impaction plate 70 preferably has at least two orifices 72 each having a diameter 112 of about 0.2mm to about 0.8mm and more preferably about 0.3mm to 0.6mm, and most preferably about 0.4mm. The impaction plate 70 can be made of paper, plastic, or metal, and more preferably made of a paper product or other suitable material having degradability properties. The impaction plate 70 preferably is made of foamed cellulose or foamed cellulose acetate or any other type of cellulosic material or cellulose acetate that can be formed into the desired shape of the impaction plate 70. The cellulosic material may be derived from tobacco, such as a cellulosic material derived from tobacco stems.

FIG. 5 shows a side view of the at least one impaction plate 70 of the smoking article 10 of FIGS. 2 and 3. As shown in FIG. 5, the impaction plate 70 preferably has a length 114 of about 2.0mm to 6.0mm and more preferably about 3.0mm to 5.0mm, and an inner length 115 of about 1.0mm to 3.0mm and more preferably about 1.5mm to 2.25mm. The spacing 116 (*i.e.*, the difference between the outer length 114 and the inner length 115 divided by 2) is preferably about 1.5mm to about 2.25mm. The spacing 116 created by the difference in the outer length 114 and the inner length 115 forms an upstream cavity 118 and a downstream cavity 119. The upstream cavity 118 is positioned between the upstream plug 42 of filtering material and the impaction filter 44, with the downstream cavity 119 positioned between the impaction filter 44 and the downstream plug 46 of filtering material.

FIG. 6 shows a cross sectional view of a smoking article 10 according to a further embodiment having a filter system 40 with an impaction filter 44, which comprises a first or upstream impaction plate 80 and a second or downstream impaction plate 90. As shown in FIG. 6, the filter system 40 is comprised of a first or upstream plug 42 of filtering material, an impaction filter 44 and a second or downstream plug 46 of filtering material. The impaction filter 44 comprises a first or upstream plate 80 having a plurality of orifices 72. The plurality of

orifices 72 as shown in FIG. 7, are equally spaced around an outer perimeter of the first plate 80. However, it can be appreciated that the plurality of orifices 72 can be spaced in any suitable arrangement. A second or downstream plate 90 having a central orifice 92 as shown in FIG. 8 is positioned downstream of the first or upstream plate 80.

The upstream plug 42 of filtering material and the downstream plug 46 of filtering material each has a generally cylindrical shape, and an outer diameter 52 thereof that is essentially equal to the outer diameter of the tobacco rod 20. The filtering material is preferably a cellulose acetate material. However, the filtering material can be carbon-on-tow or any other suitable filtering material. The filter system 40 typically has an overall length 56 of about 15 to 40 mm in length for a smoking article 10 having an overall length 58 of about 80 to 160 mm. Each plug 42, 46 of filtering material can have an equal length 54, or the upstream and downstream plugs 42, 46 can have different lengths 54. It can also be appreciated that the length 54 of the upstream and downstream plugs 42, 46 of filtering material can vary depending on additional materials within the filtering material including activated carbons or other gas-vapor phase sorbent or additive materials.

As shown in FIG. 6, the impaction filter 44 comprises an upstream plate 80 (FIG. 7) having a plurality of orifices 72 and a downstream plate 90 (FIG. 8) having a central orifice 92 located an equal distance from an outer perimeter of the downstream plate 90. In one embodiment, the upstream and the downstream plates 80, 90 preferably have a thickness 96 (FIG. 9) of about 0.5mm to about 1.5mm and more preferably a thickness of about 1.0mm. The upstream and downstream plates 80, 90 preferably have the same outer diameter 110 as the upstream and downstream plugs 42, 46 of filtering material. The impaction filter 44 preferably has a length 47 of about 3.0mm to about 10.0mm and more preferably about 4.0mm to 7.0mm. The upstream plate 80 and the downstream plate 90 are preferably separated by a distance 49 of about 0.5mm to 2.5mm and more preferably about 0.75mm to about 1.5mm and most preferably about 1.0mm.

In one embodiment, as shown in FIG. 6, the upstream plug 42 of filtering material and downstream plug 46 of filtering material have an outer diameter 52 of about 6.5mm to about 8.5mm for an impaction filter 44 having an outer diameter of about 7.4mm to about 7.8mm. In addition, the upstream and downstream plugs 42, 46 of filtering material preferably have a length of about 2.5mm to about 20mm, and more preferably about 5mm to 10mm and most preferably about 7mm for a smoking article having a length of about 80mm to 160mm. Furthermore, the upstream and the downstream plates 80, 90 can have an outer diameter 110 of about 6.5mm to about 8.5mm for an impaction filter having an outer diameter of about 7.5mm. In use, the impaction filter 44 preferably has a resistance to draw (RTD) of less than 60mm water gauge.

The upstream and downstream plates 80, 90 can be made of paper, plastic or metal of any desired thickness. However, the upstream and downstream plates 80, 90 are preferably made of a paper product for degradability. The upstream and downstream plates 80, 90 are placed between the upstream and downstream plugs 42, 46 of filtering material, which is preferably cellulose acetate. In addition, the upstream and downstream plates 80, 90 are preferably not visible to the smoker.

FIG. 7 shows a view of the impaction filter 44 of FIG. 6 along the line 7-7. As shown in FIG. 7, the upstream plate 80 has a plurality of orifice 72, which are preferably equally spaced along the perimeter of the plate. Preferably, the upstream plate 80 is comprised of 4 to 12 orifices 72 and more preferably about 8. However, it can be appreciated that any number of orifices 72 can be used. The number of orifices 72 as well as their size and position in the upstream plate 80 depend on the desired resistance-to-draw (RTD) or pressure drop, and efficiency for the impaction filter 44. It can be appreciated that one or more impaction plates 70 having a plurality of orifices 72 can also be used. In addition, spacing between the one or more impaction plates 70 can be determined by the desired efficiency. The orifices 72 preferably have a diameter 112 of about 0.2mm to about 0.8mm, and more preferably about 0.4mm.

FIG. 8 shows a cross sectional view of the impaction filter 44 of FIG. 6 along the line 8-8. As shown in FIG. 8, the downstream plate 90 has a centrally located orifice 92. The orifice 92 has a diameter 94 of about 1.0mm to about 3.0mm and more preferably about 2.0mm.

FIG. 9 shows a cross sectional view of another embodiment of a smoking article 10 having a filter system 40, wherein the smoking article 10 minimizes the ratio of total particulate matter (TPM) and tar yield by incorporating into the filter system 40 at least one impaction plate 70. As shown in FIG. 9, the smoking article 10 comprises a tobacco rod 20 of smoking material 21 and a filter system 40 with a series of ventilation holes 60. Ventilation holes 60 dilute the smoke drawn through the smoking article 10. Alternatively, if the smoking article does not have ventilation holes 60 or the holes 60 are covered, the concentration of smoke constituents drawn through the filter system 40 is higher. The ventilation holes 60 as shown in FIG. 9 are positioned upstream of the impaction filter 44. However, it can be appreciated that the ventilation holes 60 can in an alternative embodiment be positioned downstream of the impaction filter 44.

The impaction filter 44 as shown in FIG. 9 comprises an upstream plate 80 having a plurality of orifices 72 and a downstream plate 90 having a single centrally positioned orifice 92. The ventilation holes or perforations 60 on the upstream side of the impaction filter 44 minimize the ratio of total particulate matter (TPM) and tar yield by minimizing the flow change through the coal of the tobacco rod 20 and by balancing the tobacco rod 20 flow and filter 40 ventilation flow as a function of the flow rate out of the downstream end 18 of the filter system 40. As a result of an increased level of ventilation from the ventilation holes or perforations 60 within the

filter system 40, the gaseous smoke constituents of the mainstream smoke such as carbon monoxide (CO) and nitrogen oxides (NO) can also be reduced.

FIG. 10 shows another embodiment of a smoking article 10 similar to FIG. 3 comprising a filter system 40 having an upstream plug 42 of filtering material in the form of a carbon-on-tow material, an impaction filter 44 as shown in FIG. 9 and a downstream plug 46 of cellulose acetate. As shown in FIG. 10, the series of ventilation holes or perforations 60 are positioned upstream from the impaction filter 44, which is comprised of the upstream and the downstream plates 80, 90. The upstream plug 42 of carbon-on-tow as shown in this embodiment is preferably about 15.0mm to 30.0mm in length, and more preferably about 20mm to 25mm in length.

FIG. 11 shows a cross sectional view of another embodiment of a smoking article 10 having a filter system 40 with an impaction filter 44 having upstream and downstream plates 80, 90. As shown in FIG. 11, the impaction filter 44 is placed upstream from the ventilation holes or perforations 60 (i.e., between the tobacco rod 20 and the ventilation holes 60). Using this impaction filter 44, the ventilation levels within the smoking article 10 increase with the increase of puff volume as well, and therefore, minimizes the airflow through the coal of the burning tobacco rod 20. The upstream plate 80 reduces the total particulate matter and the downstream plate 90 increases the ventilation as the puff volume increases.

FIG. 12 shows a further embodiment of a smoking article 10 as shown in FIG. 11, wherein the ventilation holes 60 are positioned downstream of the upstream and downstream plates 80, 90. As shown in FIG. 12, the filter system 40 is comprised of an upstream plug 42 of carbon-on-tow 45, an impaction filter 44, and a downstream plug 46 of cellulose acetate. The impaction filter 44 is comprised of the upstream plate 80 having a plurality of orifices 72 and a downstream plate 90 having a single orifice 92. The plurality of orifices 72 for the upstream plate 80 are preferably 2 to 12 in number and more preferably 4 to 8, and most preferably 4. The plurality of orifices 72 preferably have a diameter 112 of about 0.2mm to 0.6mm and more preferably about 0.4mm. The single orifice 92 is preferably concentrically or centrally positioned within the downstream plate 90 and has a diameter 94 of about 0.5mm to 4mm, and more preferably about 1.0mm to 2.0mm. The upstream plug 42 of carbon-on-tow has a length of about 10mm to 20mm and more preferably about 14 to 16 mm, the impaction filter 44 having a total length of about 5.0mm with a 1.0mm separation between the upstream plate 80 and the downstream plate 90. The downstream plug 46 of filtering material in the form of cellulose acetate has a length of about 10mm to 20mm and more preferably about 15mm.

FIG. 13 shows the upstream plate 80 of the smoking article 10 as shown in FIG. 12. As shown in FIG. 13, the upstream plate 80 has a plurality of orifices 72, which are preferably equally spaced within the perimeter of the upstream plate 80. Preferably, the upstream plate 80 is comprised of 2 to 12 orifices 72 and more preferably 4. However, it can be appreciated that

any number of orifices 72 can be used. The number of orifices 72 as well as their size and position in the upstream plate 80 depend on the desired resistance-to-draw (RTD) or pressure drop, and efficiency for the impaction filter 44. It can be appreciated that one or more upstream plates 80 having a plurality of orifices 72 can be used. In addition, spacing between the one or more upstream plates 80 and downstream plate 90 can be determined by the desired efficiency. The orifices 72 preferably have a diameter 74 of about 0.2mm to about 0.8mm, and more preferably about 0.4mm.

FIG. 14 shows the downstream plate 90 of the smoking article 10 as shown in FIG. 12. As shown in FIG. 14, the downstream plate 90 has a centrally located orifice 92. The orifice 92 has a diameter 94 of about 1.0mm to about 3.0mm and more preferably about 2.0mm.

As shown in FIGS. 13 and 14, the upstream and downstream plates 80, 90 preferably have the same outer diameter as the cigarette filter system 40 and can be made of plastic, metal, foamed cellulose or a paper material of desired thickness. The number of orifices 72, 92 as well as their size and position in the upstream and downstream plates 80, 90 can be any suitable number to provide a desired resistance to draw (RTD), pressure drop, ventilation levels, and particulate efficiency for the impaction filter 44. If more than one upstream and downstream plate 80, 90 is used, the spacing between the plates 80, 90 can vary depending on the desired efficiency.

FIG. 15 shows another embodiment of a smoking article 10 having a filter system 40 comprising an upstream plug 42 of filtering material, an impaction filter 44, a hollow acetate tube filter 100 and a downstream plug 46 of filtering material. As shown in FIG. 15, the impaction filter 44 is comprised of the upstream plate 80 having a plurality of orifices and a downstream plate 90 having a single orifice 92. The hollow acetate tube filter 100 is positioned between the impaction filter 44 and the downstream plug 46 of filtering material, (i.e. downstream side of the impaction filter 44). The hollow acetate tube filter 100 is preferably comprised of a cellulose acetate filter 104 with a central or concentric opening 102. The filtering material 104 can be optionally surrounded by a porous wrap 106. The filtering material 104 can also include carbon or other suitable materials.

As shown in FIG. 15, the filter system 40 is preferably comprised of an upstream plug 42 of cellulose acetate tow of about 7.0mm in length, an impaction filter of about 5.0mm in length, a hollow acetate tube filter 100 of about 15mm in length with a filtering material 104 of cellulose acetate mixed with carbon, and a downstream plug 46 of cellulose acetate tow of about 6.0mm to 8.0mm in length and more preferably about 7.0mm in length.

FIG. 16 shows another embodiment of the smoking article 10 having an impaction filter 44 having upstream and downstream plates 80, 90. As shown in FIG. 17, the downstream plate 90 is coated with microencapsulated flavorants 130. In use, upon impact of the high velocity smoke against the downstream plate 90, the microencapsulated flavorants 130 are released

into the smoke stream. The microencapsulated flavorants 130 are released as a result of the kinetic and other related forces from the high velocity smoke impacting the downstream plate 90.

As shown in FIG. 16, the filter system 40 is comprised of an upstream plug 42 of carbon-on-tow, an impaction filter 44 and a downstream plug 46 of cellulose acetate. The impaction filter 44 is comprised of the upstream plate 80 (FIG. 18) having a plurality of orifices 72 and a downstream plate 90 (FIG. 17) having a single orifice 92 with microencapsulated flavorants 130. The plurality of orifices 72 for the upstream plate 80 preferably are about 2 to 12 in number and more preferably 4 to 8, and most preferably 4 and having a diameter of about 0.2mm to 0.6mm and more preferably about 0.4mm. The single orifice 92 is preferably concentrically or centrally positioned within the downstream plate 90 and has a diameter of about 0.5mm to 4mm, more preferably about 1.0mm to 2.0mm. The upstream plug 42 of carbon-on-tow has a length of about 10mm to 20mm and more preferably about 14mm to 16mm. The impaction filter 44 preferably has a total length of about 5.0mm with a separation of about 0.5mm to 2.0mm and more preferably about 1.0mm between the upstream plate 80 and the downstream plate 90. The downstream plug 46 of filtering material in the form of cellulose acetate has a length of about 10mm to 20mm and more preferably about 15mm.

The microencapsulated flavorants 130 can include any suitable material that generates flavor upon impaction from the mainstream smoke. Alternatively, heat from the mainstream smoke can also release the flavorants 130 as a result of expansion, evaporation, distillation, decomposition or other suitable reactions to the mainstream smoke. The flavorants 130 can be a single component or a multi-flavored component that is suitable for use in cigarette manufacturing such as menthol and vanillin. Alternatively, the flavorants 130 can be an aroma of choice, such as peppermint, coconut, roasted, and/or toasted aromas. However, almost any flavor oil or composition can be used. In addition, the concentration of flavorants 130, on the downstream plate 90 can be adjusted or modified to provide the desired amount of flavorants 130. Thus, the concentration of the flavorants 130, on the downstream plate 90 can vary depending on the desired aroma and/or organoleptic qualities of the tobacco smoker. Alternatively, the flavorants 130 can be encapsulated as a coating or film or within an outer shell wall in the form of a capsule having a suitable shell material such as cyclo-dextrine or other suitable shell material, wherein the capsule is located in the upstream or downstream plugs 42, 46.

It will be understood that the foregoing description is of the preferred embodiments, and is, therefore, merely representative of the article and methods of manufacturing the same. It can be appreciated that variations and modifications of the different embodiments in light of the above teachings will be readily apparent to those skilled in the art. Accordingly, the exemplary

embodiments, as well as alternative embodiments, may be made without departing from the spirit and scope of the articles and methods as set forth in the attached claims.

CLAIMS:

1. A filter system for a smoking article comprising:
an upstream plug of filtering material;
an impaction filter, the impaction filter comprising at least one plate having at least one orifice; and
a downstream plug of filtering material.
2. The filter system of Claim 1, further comprising an upstream cavity and a downstream cavity, the upstream cavity provided between the upstream plug of filtering material and the impaction filter, and wherein the downstream cavity is provided between the impaction filter and the downstream plug of filtering material.
3. The filter system of Claim 1, wherein the impaction filter comprises an upstream plate having a plurality of orifices, the plurality of orifices being equally spaced around an outer perimeter of the first plate, and a downstream plate having a central orifice.
4. The filter system of Claim 1, further comprising a plug wrap, wherein the plug wrap circumscribes the upstream and downstream plugs of filtering material and the impaction filter.
5. The filter system of Claim 3, wherein the downstream plate is coated with microencapsulated flavorants.
6. A smoking article comprising:
a tobacco rod; and
a filter system according to claim 1.
7. A smoking article according to claim 6 in which the impaction filter comprises an upstream plate having a plurality of orifices and a downstream plate having a central orifice.

FIG. 1

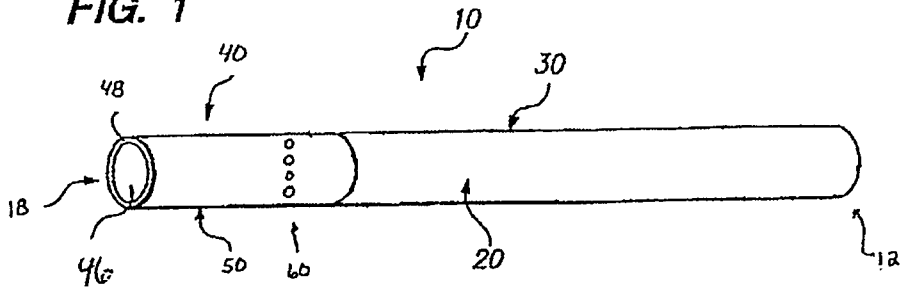

FIG. 2

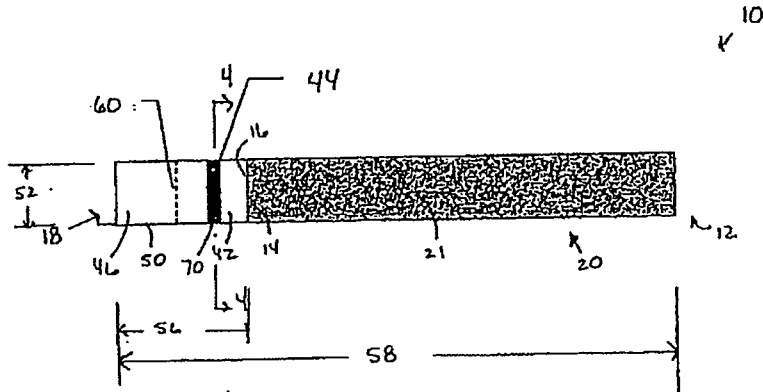

FIG. 3

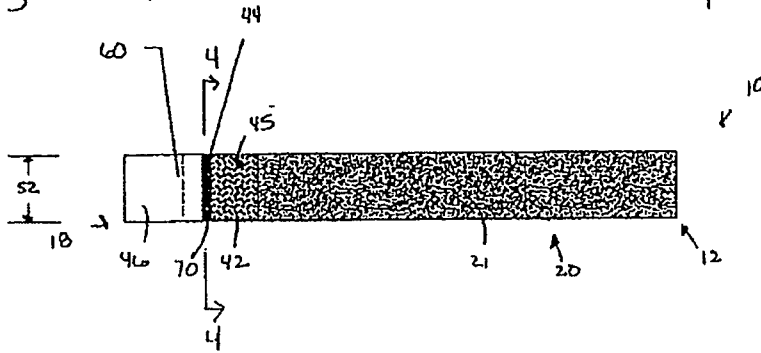

FIG. 4

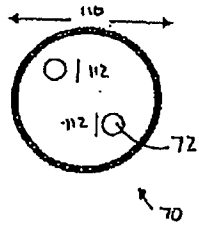

FIG. 5

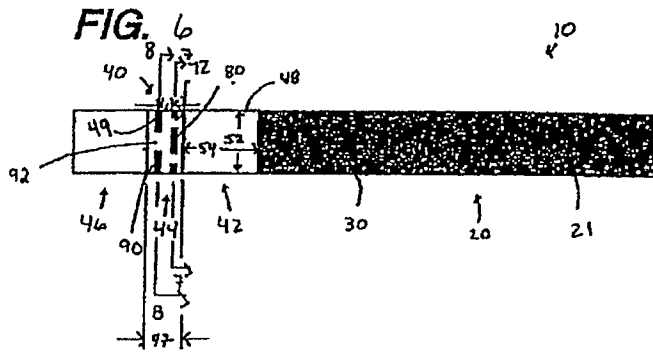
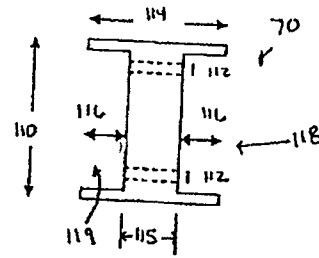

FIG. 7

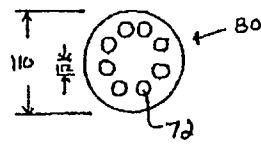

FIG. 8

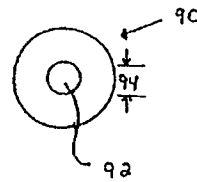

FIG. 9

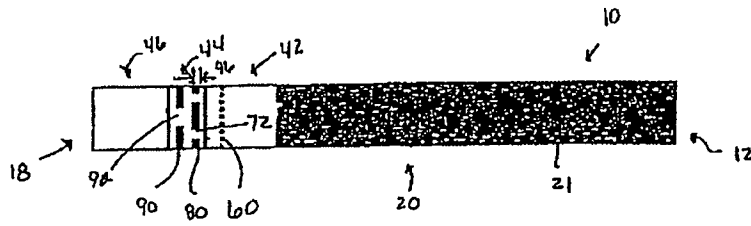

FIG. 10

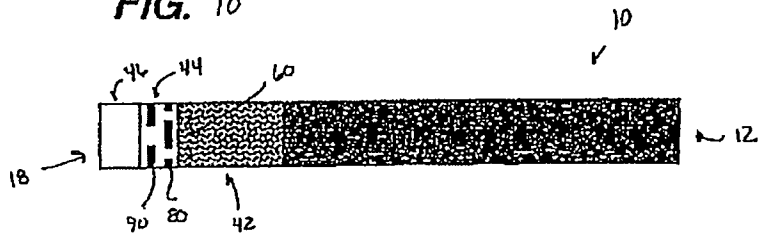

FIG. 11

