

(19) World Intellectual Property  
Organization  
International Bureau



(43) International Publication Date  
6 October 2005 (06.10.2005)

PCT

(10) International Publication Number  
**WO 2005/094016 A2**

- (51) International Patent Classification<sup>7</sup>: **H04L 12/56**
- (21) International Application Number:  
PCT/US2005/003590
- (22) International Filing Date: 2 February 2005 (02.02.2005)
- (25) Filing Language: English
- (26) Publication Language: English
- (30) Priority Data:  
10/789,187 27 February 2004 (27.02.2004) US
- (71) Applicant (for all designated States except US): **INTEL CORPORATION** [US/US]; 2200 Mission College Boulevard, Santa Clara, CA 95052 (US).
- (72) Inventors; and
- (75) Inventors/Applicants (for US only): **HONARY, Hooman** [IR/US]; 52 Clermont, Newport Beach, CA 92657 (US). **CHEN, Inching** [CN/US]; 12869 NW Lorraine Drive, Portland, OR 97229 (US). **TSUI, Ernest** [US/US]; 11260 Bubb Road, Cupertino, CA 95014 (US).
- (74) Agents: **LEMOINE, Dana, B.** et al.; Lemoine Patent Services, PLLC, c/o Portfolio IP, P.O. Box 52050, Minneapolis, MN 55402 (US).
- (81) Designated States (unless otherwise indicated, for every kind of national protection available): AE, AG, AL, AM, AT, AU, AZ, BA, BB, BG, BR, BW, BY, BZ, CA, CH, CN, CO, CR, CU, CZ, DE, DK, DM, DZ, EC, EE, EG, ES, FI, GB, GD, GE, GH, GM, HR, HU, ID, IL, IN, IS, JP, KE, KG, KP, KR, KZ, LC, LK, LR, LS, LT, LU, LV, MA, MD, MG, MK, MN, MW, MX, MZ, NA, NI, NO, NZ, OM, PG, PH, PL, PT, RO, RU, SC, SD, SE, SG, SK, SL, SM, SY, TJ, TM, TN, TR, TT, TZ, UA, UG, US, UZ, VC, VN, YU, ZA, ZM, ZW.
- (84) Designated States (unless otherwise indicated, for every kind of regional protection available): ARIPO (BW, GH, GM, KE, LS, MW, MZ, NA, SD, SL, SZ, TZ, UG, ZM, ZW), Eurasian (AM, AZ, BY, KG, KZ, MD, RU, TJ, TM), European (AT, BE, BG, CH, CY, CZ, DE, DK, EE, ES, FI, FR, GB, GR, HU, IE, IS, IT, LT, LU, MC, NL, PL, PT, RO, SE, SI, SK, TR), OAPI (BF, BJ, CF, CG, CI, CM, GA, GN, GQ, GW, ML, MR, NE, SN, TD, TG).
- Published:**  
— without international search report and to be republished upon receipt of that report
- For two-letter codes and other abbreviations, refer to the "Guidance Notes on Codes and Abbreviations" appearing at the beginning of each regular issue of the PCT Gazette.



**WO 2005/094016 A2**

(54) Title: ALLOCATION OF COMBINED OR SEPARATE DATA AND CONTROL PLANES

(57) Abstract: A dual mesh interconnect network in a heterogeneous configurable circuit may be allocated between data communication and control communication.

## ALLOCATION OF COMBINED OR SEPARATE DATA AND CONTROL PLANES

### Field

5           The present invention relates generally to reconfigurable circuits, and more specifically to programming reconfigurable circuits.

### Background

10           Some integrated circuits are programmable or configurable. Examples include microprocessors and field programmable gate arrays. As programmable and configurable integrated circuits become more complex, the tasks of programming and configuring them also become more complex.

### Brief Description of the Drawings

15           Figure 1 shows a block diagram of a reconfigurable circuit;

          Figure 2 shows a diagram of an electronic system in accordance with various embodiments of the present invention; and

          Figures 3 and 4 show flowcharts in accordance with various embodiments of the present invention.

20

### Description of Embodiments

          In the following detailed description, reference is made to the accompanying drawings that show, by way of illustration, specific embodiments in which the invention may be practiced. These embodiments are described in sufficient detail to enable those skilled in the art to practice the invention. It is to be understood that the various  
25           embodiments of the invention, although different, are not necessarily mutually exclusive. For example, a particular feature, structure, or characteristic described herein in connection with one embodiment may be implemented within other embodiments without departing from the spirit and scope of the invention. In addition, it is to be understood that  
30           the location or arrangement of individual elements within each disclosed embodiment may be modified without departing from the spirit and scope of the invention. The following detailed description is, therefore, not to be taken in a limiting sense, and the scope of the present invention is defined only by the appended claims, appropriately interpreted, along

with the full range of equivalents to which the claims are entitled. In the drawings, like numerals refer to the same or similar functionality throughout the several views.

Figure 1 shows a block diagram of a reconfigurable circuit. Reconfigurable circuit 100 includes a plurality of processing elements (PEs) and a plurality of interconnected routers (Rs). In some embodiments, each PE is coupled to a single router, and the routers are coupled together in toroidal arrangements. For example, as shown in Figure 1, PE 102 is coupled to router 112, and PE 104 is coupled to router 114. Also for example, as shown in Figure 1, routers 112 and 114 are coupled together through routers 116, 118, and 120, and are also coupled together directly by interconnect 122 (shown at left of R 112 and at right of R 114). The various routers (and PEs) in reconfigurable circuit 100 are arranged in rows and columns with nearest-neighbor interconnects, such that each row of routers is interconnected as a toroid, and each column of routers is interconnected as a toroid. In some embodiments, each router is coupled to a single PE, and in other embodiments, each router is coupled to more than one PE.

In some embodiments of the present invention, configurable circuit 100 may have a "heterogeneous architecture" that includes various different types of PEs. For example, PE 102 may include a programmable logic array that may be configured to perform a particular logic function, while PE 104 may include a processor core that may be programmed with machine instructions. In some embodiments, some PEs may implement various types of "micro-coded accelerators" (MCAs). MCAs may be employed to accelerate particular functions, such as filtering data, performing digital signal processing (DSP) tasks, or convolutional encoding or decoding. In general, any number of PEs with a wide variety of architectures may be included within configurable circuit 100.

As shown in Figure 1, PEs are connected by a dual mesh interconnect network. The dual mesh interconnect network includes a first mesh, or "plane," (shown with solid arrows between PEs) and a second mesh, or "plane," (shown with dashed arrows between PEs). In some embodiments, the first mesh is utilized for data communications between PEs, and the second mesh is utilized for control communications between PEs. In other embodiments, one or both of the planes in the dual mesh interconnect network is shared between control and data. For example, in some embodiments, control and data planes may be combined on the same mesh in part because the protocol by which data is communicated over the network may support in-band signaling. Alternatively, the control plane can be separated from the data plane, and serve as a dedicated Control and

Configuration Mesh (CCM). As described further below, dynamic allocation of the dual mesh interconnect between control and data may be performed. Dynamic allocation may be performed by a processing element within configurable circuit 100, or dynamic allocation may be performed by a processor external to configurable circuit 100.

5           In some embodiments, the routers communicate with each other and with PEs using packets of information. For example, if PE 102 has information to be sent to PE 104, it may send a packet of data to router 112, which routes the packet to router 114 for delivery to PE 104. Packets may include control information or data, and may be of any size. In some embodiments, data packets are routed between PEs using one plane of the  
10           dual mesh interconnect network, and control packets are routed between PEs using a separate plane. In other embodiments, data packets and control packets are routed between PEs on the same plane. In some embodiments, PEs are programmable in a manner that allows the dynamic allocation of the mesh between data and control. By programming or configuring a PE, the mesh may be allocated or re-allocated between data  
15           and control.

          As shown in Figure 1, configurable circuit 100 includes input/output (IO) elements 130 and 132. Input/output elements 130 and 132 may be used by configurable circuit 100 to communicate with other circuits. For example, IO element 130 may be used to communicate with a host processor, and IO element 132 may be used to communicate  
20           with an analog front end such as a radio frequency (RF) receiver or transmitter. Any number of IO elements may be included in configurable circuit 100, and their architectures may vary widely. Like PEs, IOs may be configurable or programmable, and may have differing levels of configurability based on their underlying architectures.

          Configurable circuit 100 may be configured by receiving configuration packets  
25           through an IO element. For example, IO element 130 may receive configuration packets that include configuration information for various PEs and IOs, and the configuration packets may be routed to the appropriate elements. Configurable circuit 100 may also be configured by receiving configuration information through a dedicated programming interface. For example, a serial interface such as a serial scan chain may be utilized to  
30           program configurable circuit 100.

          Configuration packets received by configurable circuit 100 may include allocation information for the dual mesh interconnect network. For example, in some embodiments, configuration packets may include PE programming information to allocate one plane of

the dual mesh interconnect network to data communication, and the other plane to control communication. In other embodiments, configuration packets may include PE programming information to allocate one or both planes to be shared between data and control communication.

5           In some embodiments, a PE or IO within configurable circuit 100 may serve as a processing element that receives configuration packets and allocates resources in the dual mesh interconnect network. For example, IO 130 may include a processor that serves as a host interface node. The host interface node may receive configuration packets and allocate resources within the dual mesh interconnect network by programming the various  
10 elements within configurable circuit 100.

Various method embodiments of the present invention may be performed by a processing element within configurable circuit 100. For example, various methods described below with reference to Figure 4 may be performed by a processor within configurable circuit 100.

15           Configurable circuit 100 may have many uses. For example, configurable circuit 100 may be configured to instantiate particular physical layer (PHY) implementations in communications systems, or to instantiate particular media access control layer (MAC) implementations in communications systems. For example, configurable circuit 100 may be configured to operate in compliance with a wireless network standard such as  
20 ANSI/IEEE Std. 802.11, 1999 Edition, although this is not a limitation of the present invention. As used herein, the term "802.11" refers to any past, present, or future IEEE 802.11 standard, including, but not limited to, the 1999 edition.

Various PHY and MAC configurations may benefit from combined data and control planes. For example, applications with high bandwidth data requirements and  
25 more flexible latency constraints may use both mesh networks for data and control to improve the overall bandwidth. Examples of PHY implementations that may benefit from combined data and control planes include wideband code division multiple access (WCDMA) base-station PHYs which may have relatively loose latency constraints, but receive data coming in from multiple antennas. WCDMA is cited as an example, and the  
30 invention is not limited in this respect.

Various PHY and MAC configurations may benefit from separate data and control planes. For example, applications with tight latency constraints may benefit from separate data and control planes, allowing for regular deterministic data flow. Examples of PHY

implementations with tight latency requirements may include orthogonal frequency division multiplexing (OFDM) implementations operating in compliance with an IEEE 802.11 standard. Also for example, applications with high control overhead or with the ability for a quick re-configuration may benefit from separate mesh structures for control and data. A separate control and configuration mesh (CCM) network may allow elements to be re-configured without impacting the normal network data traffic. In addition, it may allow time-critical control functions to be transmitted directly to each element.

In some embodiments, multiple configurations for configurable circuit 100 may exist, and changing from one configuration to another may allow a communications system to quickly switch from one PHY to another, one MAC to another, or between any combination of multiple configurations. Further, the various configurations may utilize the dual mesh interconnect network differently. In some embodiments, when switching from one configuration to another, the dual mesh interconnect network may be re-allocated between data and control. Further, in some embodiments, the dual mesh interconnect network may be re-allocated without completely changing a configuration.

In some embodiments, configurable circuit 100 is part of an integrated circuit. In some of these embodiments, configurable circuit 100 is included on an integrated circuit die that includes circuitry other than configurable circuit 100. For example, configurable circuit 100 may be included on an integrated circuit die with a processor, memory, or any other suitable circuit. In some embodiments, configurable circuit 100 coexists with radio frequency (RF) circuits on the same integrated circuit die to increase the level of integration of a communications device. Further, in some embodiments, configurable circuit 100 spans multiple integrated circuit dice.

Figure 2 shows a block diagram of an electronic system. System 200 includes processor 210, memory 220, configurable circuit 100, RF interface 240, and antenna 242. In some embodiments, system 200 may be a computer system to develop configurations for use in configurable circuit 100. For example, system 200 may be a personal computer, a workstation, a dedicated development station, or any other computing device capable of creating a configuration for configurable circuit 100. In other embodiments, system 200 may be an "end-use" system that utilizes configurable circuit 100 after it has been programmed with a particular configuration. Further, in some embodiments, system 200 may be a system capable of developing configurations as well as using them.

In some embodiments, processor 210 may be a processor that can perform methods

described below with reference to Figures 3 and 4. For example, processor 210 may perform methods that transform design descriptions into configurations for configurable circuit 100, and processor 210 may also perform methods to configure configurable circuit 100. Configurations for configurable circuit 100 may be stored in memory 220, and  
5 processor 210 may read the configurations from memory 220 when configuring configurable circuit 100. Further, when transforming design descriptions into configurations for configurable circuit 100, processor 210 may store one or more configurations in memory 220. Processor 310 represents any type of processor, including but not limited to, a microprocessor, a microcontroller, a digital signal processor, a  
10 personal computer, a workstation, or the like.

In some embodiments, system 200 may be a communications system, and processor 210 may be a computing device that performs various tasks within the communications system. For example, system 200 may be a system that provides wireless networking capabilities to a computer. In these embodiments, processor 210 may  
15 implement all or a portion of a device driver, or may implement all or part of a MAC. Also in these embodiments, configurable circuit 100 may implement one or more protocols for wireless network connectivity. In some embodiments, configurable circuit 100 may implement multiple protocols simultaneously, and in other embodiments, processor 210 may change the protocol in use by reconfiguring configurable circuit 100.  
20 Further, processor 210 may change the behavior of a protocol in use by reconfiguring a portion of configurable circuit 100.

Memory 220 represents an article that includes a machine readable medium. For example, memory 220 represents any one or more of the following: a hard disk, a floppy disk, random access memory (RAM), dynamic random access memory (DRAM), static  
25 random access memory (SRAM), read only memory (ROM), flash memory, CDROM, or any other type of article that includes a medium readable by a machine such as processor 210. In some embodiments, memory 220 can store instructions for performing the execution of the various method embodiments of the present invention. Also in some embodiments, memory 220 can store one or more configurations for configurable circuit  
30 100.

In operation of some embodiments, processor 210 reads instructions and data from memory 220 and performs actions in response thereto. For example, various method embodiments of the present invention may be performed by processor 210 while reading

instructions from memory 220.

Antenna 242 may be either a directional antenna or an omni-directional antenna. For example, in some embodiments, antenna 242 may be an omni-directional antenna such as a dipole antenna, or a quarter-wave antenna. Also for example, in some embodiments, antenna 242 may be a directional antenna such as a parabolic dish antenna or a Yagi antenna. In some embodiments, antenna 242 is omitted, and in other embodiments, antenna 242 includes multiple antennas or multiple antenna elements.

In some embodiments, RF signals transmitted or received by antenna 242 may correspond to voice signals, data signals, or any combination thereof. For example, in some embodiments, configurable circuit 100 may implement a protocol for a wireless local area network interface, cellular phone interface, global positioning system (GPS) interface, or the like. In these various embodiments, RF interface 240 may operate at the appropriate frequency for the protocol implemented by configurable circuit 100. RF interface 240 may include any suitable components, including amplifiers, filters, mixers, and the like. In some embodiments, RF interface 240 is omitted.

Figure 3 shows a flowchart in accordance with various embodiments of the present invention. In some embodiments, method 300, or portions thereof, is performed by an electronic system, or an electronic system in conjunction with a person's actions. In other embodiments, all or a portion of method 300 is performed by a control circuit or processor, embodiments of which are shown in the various figures. Method 300 is not limited by the particular type of apparatus, software element, or person performing the method. The various actions in method 300 may be performed in the order presented, or may be performed in a different order. Further, in some embodiments, some actions listed in Figure 3 are omitted from method 300.

Method 300 is shown beginning with block 310 where a design description is translated into configurations for a plurality of heterogeneous processing elements (PEs). For example, a design description representing a final configuration for a configurable circuit such as configurable circuit 100 (Figures 1, 2) may be translated into configurations for PEs such as those shown in Figure 1. In some embodiments, translating a design description may include many operations. For example, a design description may be in a high level language, and translating the design description may include partitioning, parsing, grouping, placement, and the like. In other embodiments, translating a design description may include few operations. For example, a design description may be



represented using an intermediate representation, and translating the design description may include generating code for the various PEs.

In some embodiments, a configuration specified by the design description in block 310 may be in the form of an algorithm that a particular PHY, MAC, or combination thereof, is to implement. The algorithm may be in the form of a procedural or object-oriented language, such as C or C++, or may be written in a specialized, or “stylized” version of a high level language.

In some embodiments, constraints may be specified to guide the translation of a design description. Constraints may include minimum requirements that the completed configuration should meet, such as latency and throughput constraints. In some embodiments, various constraints are assigned weights so that they are given various amounts of deference during the translation of the design description. In some embodiments, constraints may be listed as requirements or preferences, and in some embodiments, constraints may be listed as ranges of parameter values. In some embodiments, constraints may not be absolute. For example, if the target reconfigurable circuit includes a data path that communicates with packets, the measured latency through part of the design may not be a fixed value but instead may be one with a statistical variation.

At 320, a plurality of mesh interconnect networks are allocated between data and control. In this context, “allocating” refers to determining which portion of a mesh interconnect network within a configurable circuit is to be used for control information, and which portion is to be used for data information. As described above, separate meshes may be allocated to provide for separate data and control planes, or one or more meshes may be allocated to provide for combined data and control planes.

In some embodiments, one result of “allocating” includes the generation of configuration information for PEs. For example, a PE may, in general, send or receive data or control information on either or both of the mesh interconnects shown in Figure 1. By generating configuration information for a PE, method 300 may determine the PE’s behavior with respect to mesh interconnect usage.

Method 300 may measure a “quality” of the configuration, and repeat all or portions of the actions listed in blocks 310 or 320. For example, the quality of the current configuration may be measured by a “profiler” implemented in hardware or software. In some embodiments, a profiler may allow the gathering of information that may be

compared against constraints to determine the quality of the current configuration. For example, a profiler may be utilized to determine whether latency or throughput requirements can be met by the current configuration. If constraints are not met, or if the margin by which they are met is undesirable, portions of blocks 310 or 320 may be  
5 repeated. For example, a design may be placed or routed differently, or the mesh interconnect may be allocated differently, or any combination of changes may be made to the configuration. Evaluation may include evaluating a cost function that takes into account many possible parameters, including constraints.

A completed configuration is output from 320 when the constraints are met. In  
10 some embodiments, the completed configuration is in the form of a file that specifies the configuration of a configurable circuit such as configurable circuit 100 (Figure 1). In some embodiments, the completed configuration is in the form of configuration packets to be loaded into a configurable circuit such as configurable circuit 100. The form taken by the completed configuration is not a limitation of the present invention.

15 At 330 of method 300, a configuration file is written. In some embodiments, the file may include configuration information for PEs, including information governing the allocation of one or more mesh interconnect networks. If more than one design description is to be translated, then block 340 causes method 300 to translate another design. Otherwise, method 300 ends at 350.

20 At the completion of method 300, one or more configuration files exist, where each configuration file specifies a configuration for a configurable circuit. Each configuration may allocate the dual mesh interconnect network differently. For example, one configuration file may have separate control and data planes, and another protocol file may have combined control and data planes.

25 Figure 4 shows a flowchart in accordance with various embodiments of the present invention. In some embodiments, method 400, or portions thereof, is performed by an electronic system, a control circuit, a processor, a configurable circuit, or a processing element (PE), embodiments of which are shown in the various figures. Method 400 is not limited by the particular type of apparatus or software element performing the method.  
30 The various actions in method 400 may be performed in the order presented, or may be performed in a different order. Further, in some embodiments, some actions listed in Figure 4 are omitted from method 400.

Method 400 is shown beginning with block 410 where a configuration file is read

from memory. A configuration file may be read by a processor in an electronic system, or may be read by an element within a configurable circuit. For example, a processor such as processor 210 (Figure 2) may read a configuration file, or a processing element or input/output element such as IO 130 (Figure 1) may read a configuration file. The  
5 memory may be memory within an electronic system such as system 200 (Figure 2), or may be memory dedicated within a configurable circuit.

At 420, a plurality of processing elements in a heterogeneous reconfigurable device are configured. In some embodiments, this corresponds to a processor in an electronic system sending configuration packets to a configurable circuit such as  
10 configurable circuit 100 (Figures 1, 2). In other embodiments, this corresponds to an element within a configurable circuit receiving configuration information and distributing it to appropriate processing elements.

In some embodiments, only a portion of a heterogeneous reconfigurable device is configured at 420. For example, a reconfigurable device may implement multiple wireless  
15 network protocols simultaneously, and less than all of the multiple protocols may be changed while others remain. When configuring a device in this manner, configuration information may be sent across a dedicated control mesh within the reconfigurable device without disturbing data traffic. By having separate data and control planes, actions in block 420 may be performed without adverse impacts on data bandwidth. Also in some  
20 embodiments, configuration information may be sent to a portion of a heterogeneous reconfigurable device using combined data and control planes. In these embodiments, control information may utilize bandwidth that would otherwise be available to data traffic.

At 430, a plurality of mesh networks are allocated for data and control in the  
25 heterogeneous reconfigurable device. In this context, "allocating" refers to sending configuration information to PEs to affect their behavior with respect to the use of the mesh interconnect. For example, if a configuration file includes configuration information for configuring separate data and control planes, various processing elements may be configured in a manner that allocates one mesh for control communications and another  
30 mesh for data communications. Also for example, if a configuration file includes configuration information for configuring shared data and control planes, various processing elements may be configured in a manner that allocates one or more meshes to be shared for data and control communications.

Although the present invention has been described in conjunction with certain embodiments, it is to be understood that modifications and variations may be resorted to without departing from the spirit and scope of the invention as those skilled in the art readily understand. Such modifications and variations are considered to be within the  
5 scope of the invention and the appended claims.

What is claimed is:

1. A method comprising allocating a plurality of mesh networks for data and control in a heterogeneous reconfigurable device.
- 5 2. The method of claim 1 further comprising:  
reading a protocol file from a memory; and  
configuring a plurality of heterogeneous processing elements;  
wherein the protocol file includes allocation information for the plurality of mesh networks.
- 10 3. The method of claim 1 wherein the plurality of mesh networks includes a first plane and a second plane, and allocating comprises dedicating the first plane to control and dedicating the second plane to data.
4. The method of claim 3 further comprising re-allocating the first plane to be shared between data and control.
- 15 5. The method of claim 1 wherein the plurality of mesh networks includes a first plane and a second plane, and allocating comprises allocating the first plane to be shared between data and control.
6. The method of claim 1 wherein the plurality of mesh networks includes a first plane and a second plane, and allocating comprises allocating both the first plane and the  
20 second plane to be shared between data and control.
7. A method comprising:  
translating a design description into a configuration for a plurality of heterogeneous processing elements; and  
allocating a plurality of mesh interconnect networks between data and control.
- 25 8. The method of claim 7 wherein allocating comprises determining whether latency constraints can be met with a shared data and control mesh network.

9. The method of claim 7 wherein translating and allocating results in a protocol file, the method further comprising storing the protocol file in a memory.
10. The method of claim 9 further comprising translating a second design description and performing a second allocation, resulting in a second protocol file, and storing the  
5 second protocol file in the memory.
11. An apparatus including a medium to hold machine-accessible instructions that when accessed result in a machine performing:  
allocating a plurality of mesh networks for data and control in a heterogeneous reconfigurable device.
- 10 12. The apparatus of claim 11 wherein the plurality of mesh networks includes a first plane and a second plane, and allocating comprises dedicating the first plane to control and dedicating the second plane to data.
13. The apparatus of claim 12 further comprising re-allocating the first plane to be shared between data and control.
- 15 14. The apparatus of claim 11 wherein the plurality of mesh networks includes a first plane and a second plane, and allocating comprises allocating the first plane to be shared between data and control.
15. An apparatus comprising:  
a heterogeneous network of processing elements; and  
20 first and second mesh networks coupled to the heterogeneous network of processing elements, wherein the apparatus is programmable to utilize the first and second mesh networks for any combination of data and control.
16. The apparatus of claim 15 further comprising a processor to dynamically allocate the first and second mesh networks between data and control.

17. The apparatus of claim 15 wherein the heterogeneous network of processing elements are configurable to communicate over the first and second mesh networks using packets of information.

18. The apparatus of claim 15 wherein the heterogeneous network of processing  
5 elements is configurable to utilize the first mesh network for data communication and the second mesh network for control communication.

19. The apparatus of claim 18 wherein the heterogeneous network of processing elements is configurable to utilize the first mesh network for data communication and the second mesh network for both data and control communication.

10 20. The apparatus of claim 18 wherein the heterogeneous network of processing elements is configurable to utilize both the first and second mesh networks for both data and control communication.

21. An apparatus comprising:  
a dual mesh interconnect network; and  
15 a plurality of processing elements coupled to the dual mesh interconnect network, wherein the plurality of processing elements are configurable to utilize the dual mesh interconnect network for any combination of data and control.

22. The apparatus of claim 21 further comprising a processor to configure the plurality of processing elements.

20 23. The apparatus of claim 21 further comprising a plurality of routers coupled between the dual mesh interconnect network and the plurality of processing elements.

24. The apparatus of claim 21 wherein the dual mesh interconnect network includes a first plane and a second plane, and the plurality of processing elements are configurable to  
25 utilize the first plane for data communication and the second plane for control communication.

25. The apparatus of claim 24 wherein the plurality of processing elements are configurable to utilize the first plane for data communication and the second plane for both data and control communication.

26. The apparatus of claim 24 wherein the plurality of processing elements are  
5 configurable to utilize both the first and second planes for both data and control communication.

27. An electronic system comprising:  
an antenna;  
a radio frequency circuit to receive communications signals from the antenna; and  
10 a reconfigurable device coupled to the radio frequency circuit, the reconfigurable device including a dual mesh interconnect network, and a plurality of processing elements coupled to the dual mesh interconnect network, wherein the plurality of processing elements are configurable to utilize the dual mesh interconnect network for any combination of data and control.

15 28. The electronic system of claim 27 further comprising a processor to configure the plurality of processing elements.

29. The electronic system of claim 27 wherein the dual mesh interconnect network includes a first plane and a second plane, and the plurality of processing elements are configurable to utilize the first plane for data communication and the second plane for  
20 control communication.

30. The electronic system of claim 29 wherein the plurality of processing elements are configurable to utilize the first plane for data communication and the second plane for both data and control communication.

25



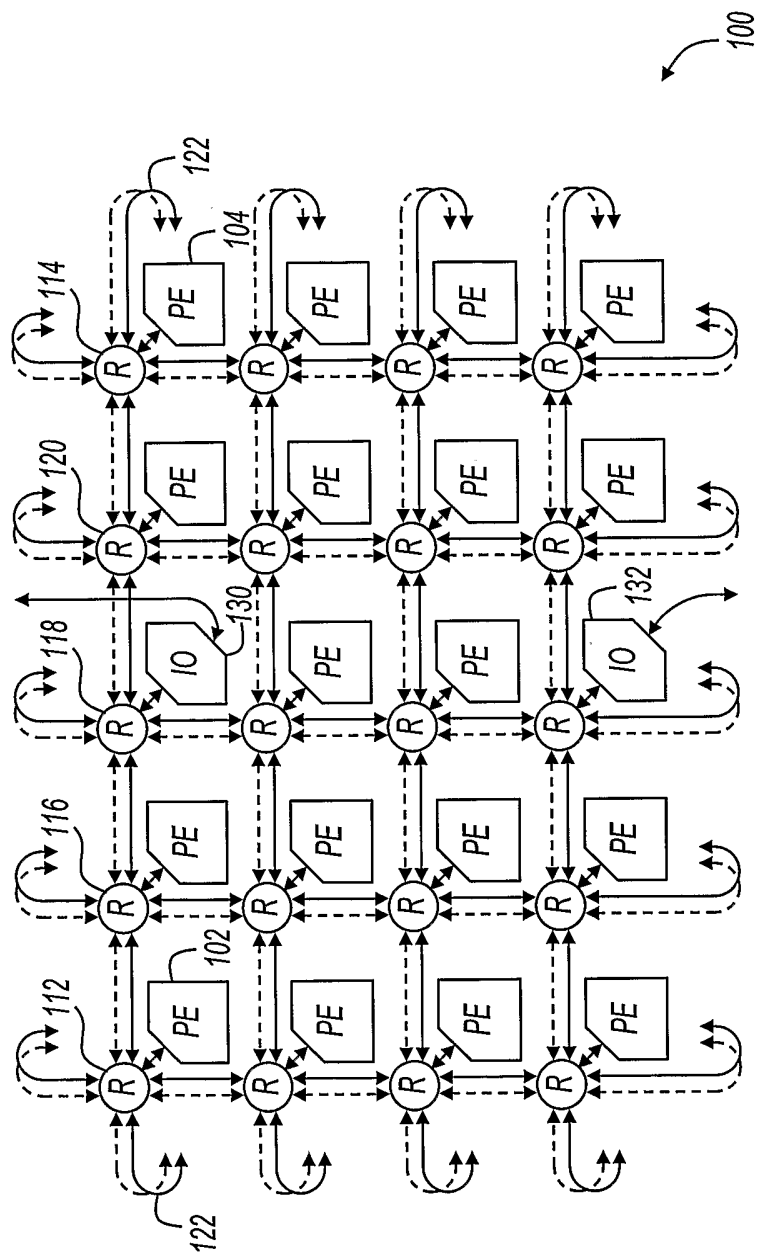

FIG. 1

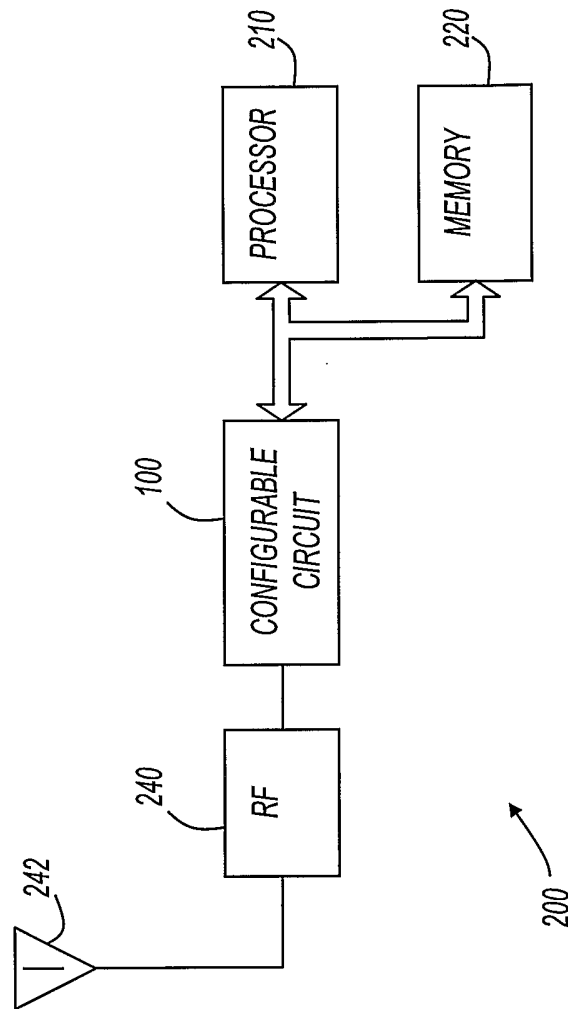

FIG. 2

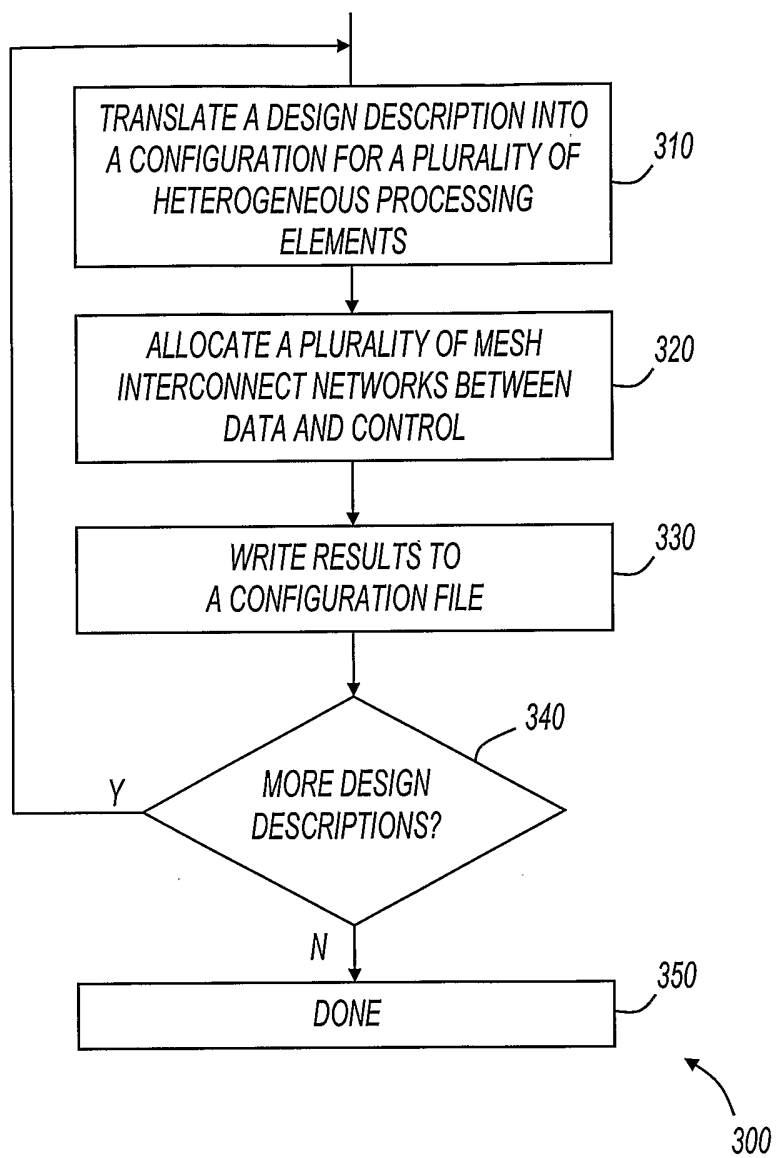

FIG. 3

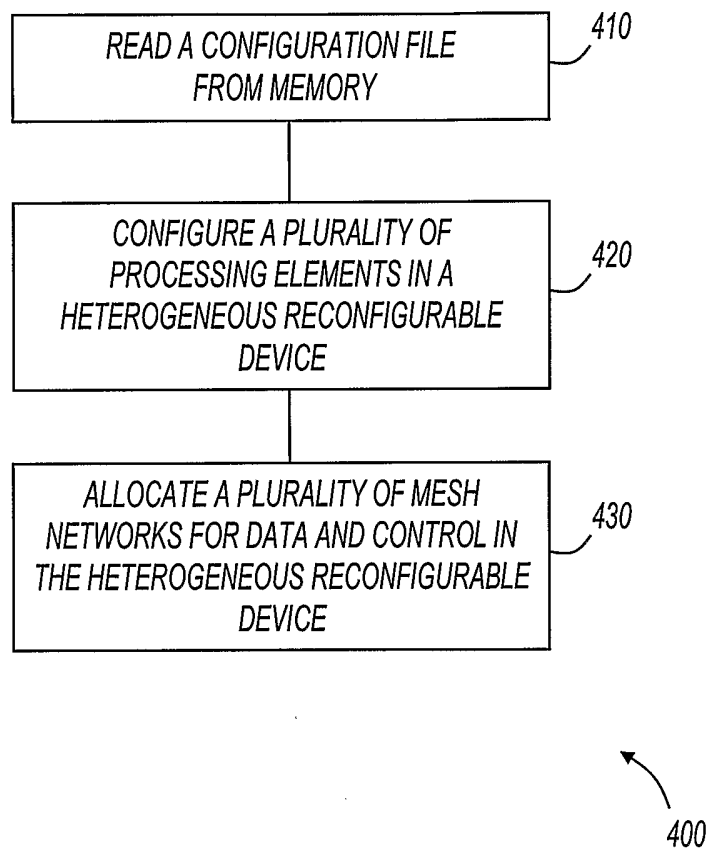

FIG. 4