

F. A. IRONS.  
METALLIC PACKING DEVICE.

(Application filed July 10, 1901.)

(No Model.)

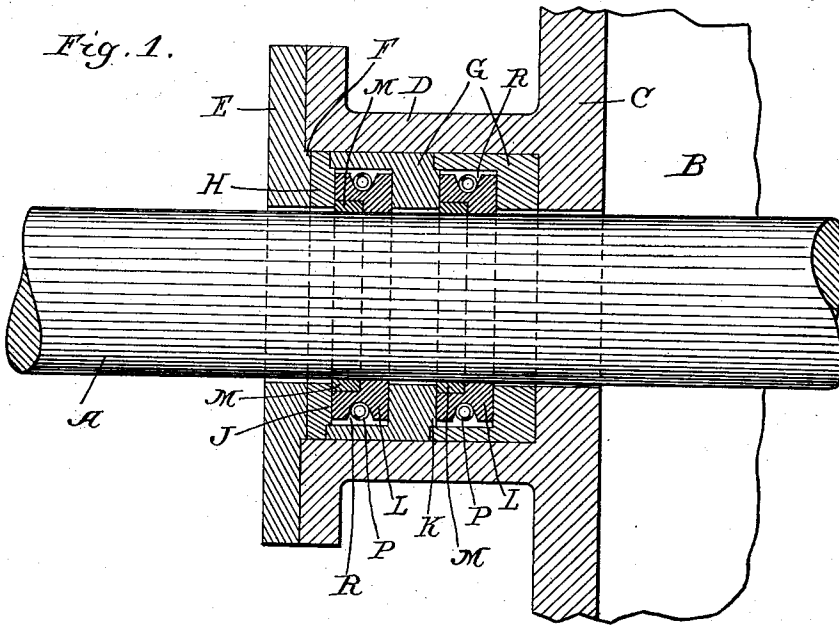

Fig. 2.

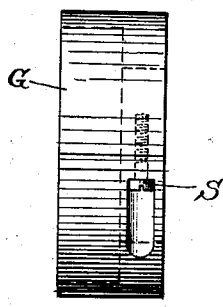

Fig. 3.

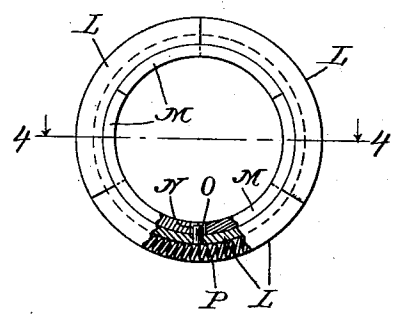
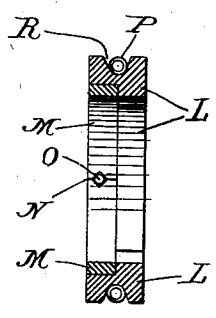

Fig. 4.



Witnesses.

Edward T. Wray,  
Homer L. Craft

Inventor.

Fred A. Irons  
by Parker Carter,  
his Atty.

# UNITED STATES PATENT OFFICE.

FRED A. IRONS, OF CHICAGO, ILLINOIS, ASSIGNOR OF ONE-HALF TO  
EUGENE H. GUILLOTT, OF CHICAGO, ILLINOIS.

## METALLIC PACKING DEVICE.

**SPECIFICATION** forming part of Letters Patent No. 701,730, dated June 3, 1902.

Application filed July 10, 1901. Serial No. 67,752. (No model.)

*To all whom it may concern:*

Be it known that I, FRED A. IRONS, a citizen of the United States, residing at Chicago, in the county of Cook and State of Illinois, have invented a certain new and useful Improvement in Metallic Packing Devices, of which the following is a specification.

My invention relates to metallic packing devices, particularly for steam-engine pistons, and has for its object to provide cheap and simple means for packing the rod, while allowing it a certain amount of play or oscillatory motion.

A further object is to provide a metallic packing in which the wearing portions can be easily removed and in which the parts which do not wear can be easily rearranged to accommodate themselves to the wear of the wearing portions.

A further object of my invention is to arrange the portions of the metallic packing so as to break joints one with another, and thus in a most effectual manner prevent the escape of the fluids.

Other objects and purposes of my invention will appear from the description.

I have illustrated one form of my invention or a form of metallic packing which contains my invention in the accompanying drawings, wherein—

Figure 1 is a vertical section through the packing and its associated parts with the piston-rod in position. Fig. 2 is an elevation of one of the packing-cups. Fig. 3 is a plan view with parts broken away of one of the packing-rings. Fig. 4 is a section through the same ring on line 4 4, Fig. 3.

Like parts are indicated by the same letter in all the figures.

A is the piston rod or shaft which is to be packed; B, the steam space or cylinder; C, the head or end of such cylinder; D, a gland or cup-like projection on the end C; E, a cover secured in any desired manner to the end of the cup D and preferably provided with an annular inward projection F, which lies in the cup and keeps the parts properly centered.

G G are inner cups adapted to contain each a packing-ring.

H is a ring having the inner projection J, similar to the inner projection K on the inner cup G. These inner projections fit within the respective associated cups and are adapted to hold, but not tightly and without compression, the packing-rings in position.

Each packing-ring consists of three ring-like portions L, which together form a circle, and three inner small ring-like parts M, which lie in the portion cut away from the ring portions L L. These ring-sections M M form also a circle. One of these ring-like portions is perforated at N to receive the dowel-pin O, which projects upwardly from the ring portion L, and thus the inner ring-sections are prevented from rotating upon the outer ring-sections and the joints between the ends of the outer ring-sections are placed approximately half-way between the joints formed between the ends of the inner ring-sections, as best indicated in Fig. 3. A spiral spring P is placed in a groove R, which is formed about the outer circumference of the ring-like portions L, and thus all the parts are held together. These several parts may be so shaped or formed of such length that when the rod is passed through the packing-rings they are slightly spread or so that when in this position the several rings are not perfect rings, but the ring portions are slightly separated. This will permit the devices to wear and the wear to be taken up by the action of the spiral spring, which holds and forces all the parts of each packing-ring tightly against the outer surface of the piston-rod. In order to get these several parts onto the rod after it is in position, I prefer to make the cups G G and the ring H in sections. The sections of the cups G G may be attached together by means of bolts, like the bolt S. (Indicated in Fig. 2.) In the ordinary application of metallic packing to piston-rods it is necessary to disconnect the cross-head, and by making the cups in half-sections or dividing each into two parts, as just explained, they can be put together over the rod without thus disconnecting the cross-head. The spaces between the cups and the cup and outer ring H are a trifle wider than the thickness of the packing-ring, so that the steam pass-

ing out along the rod will gather in the cup on the outside of the packing-ring and will tend to assist or replace the spring in seating the portions of the packing-ring against the rod and will also tend to seat the face of the packing-ring against the bottom of the next cup or the inner face of the ring H, and this action is repeated for each successive packing-ring. In the case of two or more rings being used there will be formed about the rod an annular lubricant-chamber for lubricating the rod.

Of course it will be evident that the sections of the packing-rings may be either greater or less than one-third of a circle and that they need not be perfectly uniform; also, that the cross-sections of these rings may be greatly varied with reference to each other and with reference to the cross-sections of the rings shown. It is important that the joints should overlap. It is also evident that any means of forcing these metallic sections of the several packing-rings toward the outer surface of the piston-rod other than the spiral spring might be used. When the rings have worn, so that they are too thin to be held properly in position between the several cups, these cups can be taken out and the outer portion or that portion of each which comes in contact with the next be slightly turned down, whereupon the rings will be found to be properly held in position. It is only necessary in such case to substitute for the outer ring H a new or proper ring to cover the outer cup.

Of course the cups or retaining-cases for the rings could be greatly varied. I have only

shown one convenient form, and the number of these cups and of the rings could be varied.

Some of the features of my invention can be utilized and employed without employing others in structures which would readily suggest themselves to any one familiar with the art after examining my invention.

I have alluded to my invention throughout as a "metallic" packing; but of course it might be applicable to other substances than metals or to such other substances as may be hereafter employed in any similar way for packing material.

I claim—

In a packing for piston-rods, the combination of a cup-like projection on the cylinder with a series of cups within such cup-like projection, a cap for the cup-like projection having an enlarged portion which fits therein, a ring fitting upon the outer cup, packing-rings one in each cup and formed of segments, an inner similar packing-ring within the first-mentioned packing-ring and also in segments, a coiled spring about the outer ring to hold the parts together and against the rod, the cups formed in segments and having free spaces about the rings so that the steam escaping along the rod is retained in the cup-like projection and tends to help set the packing-rings, and the several cups and packing-rings can be removed from the rod substantially as shown and described.

FRED A. IRONS.

Witnesses:

HOMER L. KRAFT,  
FANNY B. FAY.