

W. L. Imlay,

Hydrocarbon-Burner.

N<sup>o</sup> 73335

Patented Jan. 14, 1868.

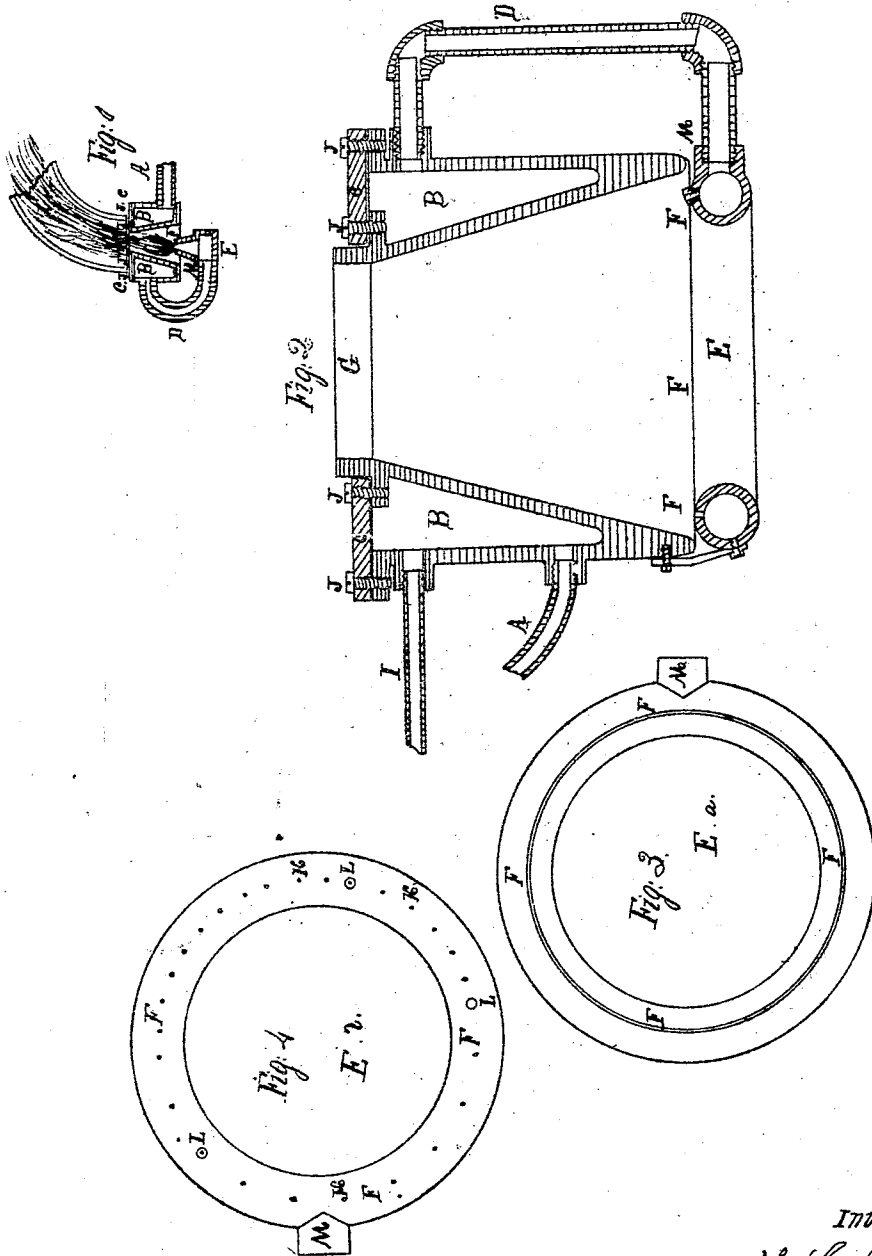

WILLIAMS  
W. L. Imlay  
Newell Imlay

INVENTOR  
W. L. Imlay

# UNITED STATES PATENT OFFICE.

W. L. IMLAY, OF PHILADELPHIA, PENNSYLVANIA.

## HYDROCARBON-BURNER.

Specification forming part of Letters Patent No. 73,333, dated January 14, 1868.

*To all whom it may concern:*

Be it known that I, WILLIAM L. IMLAY, of the city and county of Philadelphia, State of Pennsylvania, have invented an Improved Apparatus or Burner for Hydrocarbons, designed mainly for petroleum and its products; and I declare the following to be a full and exact description thereof, reference being had to the annexed drawings, and letters thereon.

Figures 1 and 2 are perpendicular sections of my apparatus, and Figs. 3 and 4 views from above of my equalizing-chamber.

My object is to produce an intense and powerful heat, which is ordinarily by a blue flame, by the combustion of the vapor and gas of petroleum or other hydrocarbons.

Others have perhaps before me made large lamp lights and flames for small cooking and heating, or varied apparatus to mingle air with the vapor and gas of hydrocarbons, or to burn the products of hydrocarbons mingled with steam; but such is no part of my object.

I design an entirely new and independent improvement—namely, the high-pressure blast of the vapor and gas of hydrocarbons, burned with no lamp-fixtures, nor aero-vapors, or mingled air-vapor and gas-fixtures, nor any steam, water, or such like fixtures, mingling steam and vapor or gas in the manner that may have been done. And, further, I so construct my burner that I apply it to flues, pipes, and articles that cannot be heated in the same manner by any such devices as I have named.

My independent and new class of apparatus in hydrocarbons I construct by several parts and devices, and thus I accomplish my object as follows: I make a strong circular chamber, capable of sustaining any graduated degree of high pressure, and into it I introduce a feed-pipe that supplies the hydrocarbon—as petroleum or gasoline—and when vaporized or more or less turned into gas this product is led by a pipe beneath the generator or chamber and into a circular pipe or receiver. The leading-pipe is comparatively large and free, and is designed to produce no check on the flow from the generator to the receiver; yet on the arrival of the vapor and gas at the receiver the high blast makes an inequality of pressure on the sides of the receiver, if small comparatively. Therefore I make the capacity of the

receiver larger than that of the flow-pipe, that the flame aperture or apertures may be evenly fed, and also fed alike. From the receiver the vapor and gas escape by one or more apertures, and are burned, merely mingling with the air by the force of the blast. The heat necessary to produce the blast is kept up by the playing of the flame against the inner wall of the generator, which is usually inclined inward or made cone-shaped, for the double purpose of being thus heated and serving as a guide to the flame and heat when used in my method. To aid in this deflection and guiding of the flame, I incline the escape aperture or apertures to one common center, and also that the heat may not melt the generator. I apply the high and powerful blast thus produced to varied objects or uses—as, for example, the heating of water, by forcing the flame thus obtained through long coils of pipe, the distillation of alcohol, and coal and petroleum oils, heating houses and buildings, and to very many other uses which I do not design to explain or claim in this specification. These and other facts are apparent in the drawings.

In Fig. 1, A is a feed-pipe, supplying the hydrocarbon from a strong reservoir, and B the chamber of the generator, made with two walls, the outer one perpendicular and the other or inner one cone-shaped or inclined, so that the bottom is large while the top is smaller. The top of this gas and vapor producing chamber is closed by a cap, C, that, ground or luted on, is removable for cleaning its inside. I also use a stop to blow off tar or impurities, and also to lessen the blast out of the flame-apertures. By a large and free pipe, D, connection is made with the receiver E and flame-escape aperture F.

In Fig. 2 the same letters show the same parts. In this figure the receiver E is made of a circular pipe larger than the free-conduct D; and I is a pipe from the generator-chamber to the upper part of the reservoir, for the equalizing of the pressure between the two, and the whole is seen larger than in Fig. 1.

In Fig. 3 the escape-aperture is shown as one slot at F F F, and in Fig. 4 as made by the drill-holes K, some of which are capped or circled with nipples of resisting substances, for the twofold purpose of preventing the blast

and also the heat from closing or expanding them.

Through G, the blast-aperture of the generator in Figs. 1 and 2, a strong and very hot blast is made, and by extending the inner wall of the generator to the top of the cap C or beyond it connection is made to the mouth of the tubes, flues, or to other articles and places to be heated. In the section of the receiver E in Fig. 1 the escape-apertures are seen inclined inward, to aid the direction of the blast burning.

The further uses and advantages of my invention are apparent to those skilled in the art to which it appertains.

I claim—

1. The construction of the vapor and gas chamber B with two walls, the outer one of any

suitable form and the inner one cone-shaped or inclined inward, and operating substantially as set forth.

2. The construction of the blast-equalizing chamber E larger than the flow-pipe D, and with the inclined apertures or escape F arranged just beneath or just within the lower part of the generator, as set forth.

3. An apparatus for burning hydrocarbons constructed and made of the pipe A from the reservoir, the chamber B, flame-blast aperture G, tube D, receiver E, and escape-apertures F, operating substantially as set forth.

W. L. IMLAY.

Witnesses:

CHAS. IMLAY,  
NEWEL IMLAY.