

Aug. 1, 1967

B. B. CHAPMAN

3,333,831

POWER-DRIVEN FLUID DISPLACEMENT APPARATUS

Filed May 13, 1966

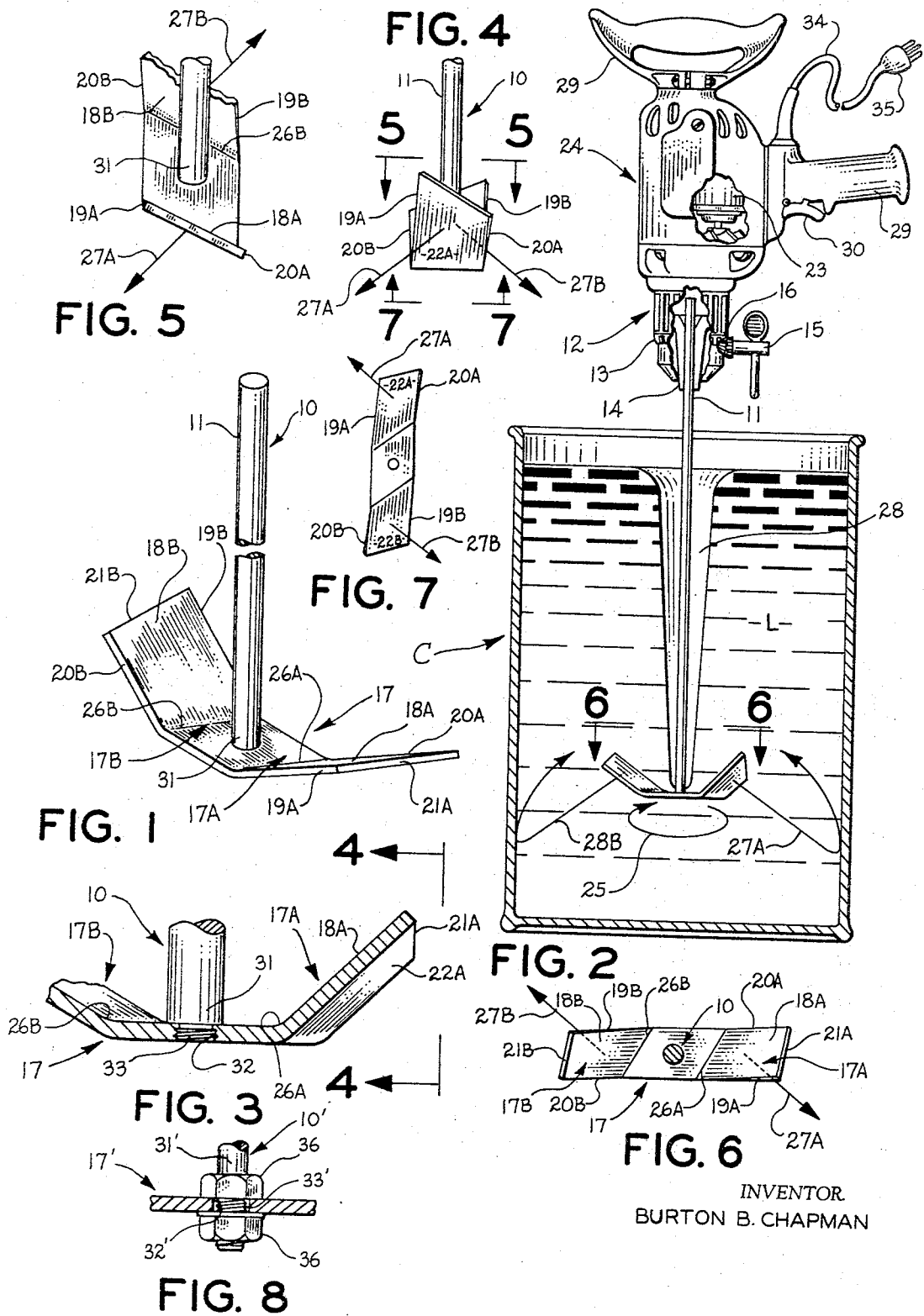

INVENTOR
BURTON B. CHAPMAN

3,333,831
**POWER-DRIVEN FLUID DISPLACEMENT
 APPARATUS**

Burton B. Chapman, 124 S. Almansor Ave.,
 Alhambra, Calif. 91801

Filed May 13, 1966, Ser. No. 549,883

11 Claims. (Cl. 259—111)

Generally speaking, the present invention relates to power-driven displacement fluid apparatus which, broadly speaking, may comprise virtually any type of fluid displacement apparatus where a driving motor means rotates a longitudinal shaft means provided with projecting blade means and effectively displaces a fluid or liquid medium relative to the rotating longitudinal shaft means and projecting blade means.

In one form of the apparatus as generally defined above, it may comprise apparatus primarily intended to be maintained in a predetermined position and operated primarily for displacing a fluid or liquid medium either for moving or effectively pumping same or for effectively mixing same and, in another form of the apparatus as generally defined above, it may be primarily adapted to produce a longitudinal axial reaction thrust applied to the longitudinal shaft means and driving motor as a result of the fluid or liquid displacement action of the rotating projecting blade means carried by the longitudinal shaft means. For example, it might comprise the equivalent of a propeller or other power-driven propelling system for a boat, or the like, when considered in this broad aspect of the present invention.

The invention may effectively combine the two different aspects mentioned in the preceding paragraph—that is, it may function for fluid or liquid displacement purposes and also for producing reaction thrust along the longitudinal shaft means in a direction toward the end thereof remote from the projecting blade means. In this latter form, particularly when the whole apparatus is employed as a mixer for mixing liquids, fluids, mixtures of liquids and solids (in other words, slurries) or any fluid, liquid, or semi-liquid medium, and in so doing is positioned upright—that is, with the longitudinal shaft means substantially vertical, with the driving motor means thereabove and with the projecting blade means being positioned in downwardly inserted relationship within a body of fluid or liquid which is to be mixed and which is carried within a container—both of the above-mentioned features are advantageous. In other words, the fluid or liquid displacement feature provides for effective mixing of the fluid or liquid, and the upward reactive thrust feature acts to substantially neutralize the weight of the entire apparatus so that there is virtually no strain on the hand and arm of a person holding the mixing apparatus in the above-mentioned downwardly inserted relationship within the fluid or liquid which is to be mixed and which is contained within an upwardly open container.

Throughout the remainder of this application, the present invention will be described primarily in connection with the power-driven mixer form thereof referred to above, but it should be clearly understood that this is done merely for exemplary purposes and is not to be construed as specifically limiting the invention to the mixer form thereof, and it should be clearly understood that the scope of the present invention is to be interpreted broadly in the light of the foregoing general definition and clarifying explanation thereof.

The exemplary mixer form of the invention may be said to effectively comprise a novel, portable, power-driven mixer attachment, per se, adapted to be attached to a portable driving motor (which, in certain forms, may be a portable electric drill motor). The mixer form of the

invention is also directed to the combination of the mixer attachment and the driving motor.

The portable power-driven mixer apparatus form of the present invention is adapted for use in mixing anything from a relatively small volume of liquid or fluid to a relatively large volume of liquid or fluid, and said liquid or fluid may, in certain cases, contain large quantities of solid material of particulate form, which may have particle sizes ranging from very finely divided plaster, gypsum, or cement through intermediate particle sizes such as sand, or the like, to relatively large particle sizes in certain instances, such as rock or aggregate, although the invention is not specifically so limited.

The liquid carrying the above-mentioned materials may have such a heavy concentration of them as to comprise a relatively thick, pasty, or very viscous slurry, or may comprise a relatively thin or non-viscous liquid, or a liquid having viscosity characteristics lying anywhere between the two just described.

The mixer form of the present invention is extremely well adapted for mixing plaster, mortar, cement, or concrete, which exemplify the thicker, more viscous type of liquid referred to above and is equally well adapted to mix paint, varnishes, other protective coatings, and the like, which exemplify the thinner or less viscous type of liquid referred to above. This is usually done by placing the liquid in a container such as a cylindrical barrel or drum, although not specifically so limited, and then inserting the mixing apparatus of the present invention downwardly thereinto and electrically energizing the driving motor of same while moving the projecting blade means and longitudinal shaft means through various positions within the liquid to be mixed.

Additionally, the mixing apparatus of the present invention lends itself very well to being fastened to a conventional electric drill, which is generally available on almost any construction job, whereby to comprise the driving unit for the mixer attachment, thus making it unnecessary to purchase a special and completely powered concrete mixer, plaster mixer, paint mixer, or the like, which would be a relatively bulky and expensive unit and which would otherwise be unusable.

Thus, it can readily be seen that the apparatus of the present invention is not only money-saving, but space-saving as well since the conventional electric drill usually present on a construction job may be employed for attachment to the mixer unit form of the present invention, and the cement, mortar, or the like, to be mixed with a quantity of water may be placed in any suitable drum or barrel for mixing just prior to actual use of the mixed cement or mortar. Alternatively, paint or other protective coating or covering which is to be mixed may be placed in any suitable drum, barrel, or other container and mixed in substantially the same manner—usually just prior to actual use thereof, although not specifically so limited.

It will readily be understood that one prior art problem which has more or less precluded the use of a portable mixer driven by a portable electric drill is the fact that the necessary size of such a unit for mixing a barrel full of cement and water, or mortar and water, would require that the combined drill and mixer unit have a very substantial weight, perhaps of the order of 40 pounds, or so, in the case of a unit adapted to mix a large quantity of cement and water or mortar and water. This would necessarily make it quite difficult for a person to use the device for mixing cement or mortar with water in a barrel since this operation would normally require holding the mixing unit for some time and probably moving it up and down and perhaps sideways within the barrel a number of times to facilitate the mixing operation. This would be extremely tiresome to do in view of the

3

combined weight of the apparatus and would require a strong man to perform the mixing operation.

However, the novel mixer attachment form of the present invention embodies an inventive concept and principle which virtually completely meets and over-comes the above-mentioned problem and makes a portable mixing unit of the type referred to above a practical, convenient, and easy-to-use device which does not require that the user have strength beyond that of the average person.

The above-mentioned novel feature arises from the fact that the mixer attachment form of the present invention is provided with a longitudinal shaft which is normally downwardly inserted into a container or barrel carrying the medium which is to be mixed, and said shaft is provided with projecting blade means including at least a first and second blade portion symmetrically positioned on opposite sides of said longitudinal shaft means and each having an outer pushing part provided with a leading edge and a trailing edge bent upwardly from a true horizontal plane and twisted so as to have its leading edge positioned at a higher, outwardly and upwardly inclined, level than the corresponding trailing edge. This arrangement causes a bottom or rear pushing surface of each of said pushing parts to be inclined upwardly and forwardly in the direction of rotation toward said leading edge and to be inclined upwardly and outwardly in an inclined radial direction away from said longitudinal shaft means whereby to exert an axially rearward or downward, circumferentially forward, and radially outward force upon a fluid or liquid medium to be mixed during rotation of said blade means by said driving motor means for causing positive displacement of said liquid or fluid medium away from said longitudinal shaft and for causing a corresponding reactive upward thrust to be exerted by said displaced liquid or fluid medium upon said rotating projecting blade means, said upwardly extending longitudinal shaft means and the driving motor positioned at the top thereof and driving same, of a magnitude such as to substantially completely neutralize the weight thereof.

For example, in one working model of the present invention intended for mixing large quantities of concrete, plaster, or the like, and which weighs approximately 40 pounds when attached to the driving electric drill motor, the operation of said upwardly bent and twisted pushing parts of said projecting blade means results in producing a reactive upward-acting force substantially equal and opposite to the downwardly acting weight of the entire unit, thus leaving the entire device virtually weightless in the hands of an operator. This makes it possible for an operator or user of the apparatus to move the entire apparatus up and down or sideways as desired in the medium being mixed within the container or barrel and without much effort on the operator's part, and also makes it possible for the operator to mix a number of batches of mortar or cement, or other media, with a minimum of fatigue. Furthermore, the arrangement of the blade means, in addition to the substantially complete supporting effect which it produces, also brings about a very effective churning and mixing of the medium which is to be mixed and does so with virtually no outward splashing or displacement of the medium being mixed over or beyond the upper rim or lip of the container carrying same.

It is an object of the present invention to provide power-driven fluid displacement and/or reaction thrust-producing apparatus of the character referred to herein generically and/or specifically and which may include any or all of the features referred to herein, either individually or in combination, and which is of relatively simple, inexpensive, easy-to-operate construction adapted for ready mass manufacture at a moderate cost per unit, whereby to be conducive to widespread production, distribution, and use of the invention.

4

It is a further object of the present invention to provide apparatus of the character referred to in the preceding object, wherein the apparatus is adapted to be employed as a fluid or liquid mixer of a very simple, inexpensive, easy-to-operate type which may cooperate with a pre-existing electric drill motor for driving same or which may be provided with an independent motor for driving same and wherein the apparatus is virtually entirely self-supporting when operated in a medium to be mixed, so that substantially all of the weight of the apparatus is sufficiently neutralized by upward reactive thrust produced by the operation of the apparatus.

Further objects are implicit in the detailed description which follows hereinafter (and which is to be considered as exemplary of, but not specifically limiting, the present invention), and said objects will be apparent to persons skilled in the art after a careful study of the detailed description which follows.

For the purpose of clarifying the nature of the present invention, two exemplary embodiments of the invention are illustrated in the hereinbelow-described figures of the accompanying single drawing sheet and are illustrated in detail hereinafter.

FIG. 1 is a partially-broken-away, fragmentary perspective view of one exemplary embodiment of the mixer attachment means form of the present invention prior to engagement with respect to a portable driving motor, such as a portable electric hand-drill motor, or the like.

FIG. 2 is a view of the mixer attachment form of the invention illustrated in FIG. 1 after engagement with the chuck of a portable electric drill (including an electric motor) and shows the longitudinal shaft and the projecting blade means in downwardly inserted mixing relationship within a hollow cylindrical container taking the form of a metal drum or barrel, although not specifically so limited. The barrel is shown in vertical section on the center plane thereof, while the connection of the mixing attachment form of the present invention and the driving electric drill are shown in partially-broken-away elevation.

FIG. 3 is a fragmentary sectional view taken substantially along a central plane of the projecting blade means and shows the right portion thereof in full longitudinal section and shows the left portion thereof in partial longitudinal section, with the left end thereof broken away for drawing space conservation reasons. The bottom or lower tip engagement end of the longitudinal shaft means is shown fragmentarily in elevation in this view rather than in central plane section in the manner of the blade means.

FIG. 4 is a right end elevational view taken substantially in the direction of the arrows 4-4 of FIG. 3, but is drawn to a reduced scale compared to the scale of FIG. 3.

FIG. 5 is a fragmentary view taken substantially in the direction of the arrows 5-5 of FIG. 4 and looking directly at the end of the near upwardly bent and angularly twisted pushing part of the near portion of the projecting blade means of FIG. 4 and clearly illustrates the extent of the angular twist thereof in an upward and forward direction with respect to the direction of rotation thereof.

FIG. 6 is a fragmentary top plan view of the projecting blade means portion of the apparatus taken substantially along the plane and in the direction indicated by the arrows 6-6 of FIG. 2.

FIG. 7 is a greatly-reduced-size bottom plan view of FIG. 4.

FIG. 8 is an enlarged fragmentary view generally similar to the central portion of FIG. 3 but illustrates a slight modification of the engagement structure by which the projecting blade means is attached to the lower end of the longitudinal shaft means.

Referring to FIGS. 1-7 for exemplary purposes, a first illustrative embodiment of the invention takes a

typical exemplary form wherein it comprises a longitudinal shaft means or shaft, as indicated generally at 10, which is normally vertically directed when in mixing use, as best shown in FIG. 2, and which has an upper engaging portion 11 which, in the example illustrated, is adapted to be removably engaged by a chuck or collet such as the one shown generally at 12 in FIG. 2, for example, and which in said illustrated form comprises a typical split chuck of the type adapted to be opened and closed by rotating the collar 13 so as to cause movement of the tapered engaging fingers 14 in a manner whereby to grip the engaging portion 11 of the shaft 10 as clearly shown in FIG. 2 or whereby to become disengaged from said engaging portion 11 of the shaft 10 as a result of oppositely directed rotation of the collar 13.

In the exemplary first form of the invention illustrated, rotation of the collar 13 is adapted to be accomplished by a splined or toothed tapered key means, such as that shown at 15, which engages the similar splined or gear-toothed portion 16 of the collar 13. This structure is well-known in the art and, therefore, will not be described in detail.

The longitudinal shaft 10 is also provided with projecting blade means, indicated generally at 17, which in the specific example illustrated, comprises a first blade portion 17A positioned on one side of the longitudinal shaft means 10 and a second blade portion, indicated at 17B, positioned on the other side of the shaft 10 in symmetrically balanced relationship and with each of said first and second blade portions 17A and 17B having an outer pushing part 18A and 18B, respectively, provided with a leading edge and trailing edge 19A and 20A in the case of the first pushing portion 18A, and 19B and 20B in the case of the second pushing portion 18B. The leading edges 19A and 20A are connected by an outer tip edge 21A, and the leading and trailing edges 19B and 20B are connected by an outer tip edge 21B. Each pushing part 18A and 18B has a bottom or rear pushing surface such as shown at 22A in the case of the pushing part 18A and such as shown at 22B in the case of the pushing part 18B.

It should be understood that the drill motor 23 of the electric drill, indicated generally at 24, is adapted to rotate the longitudinal shaft 10 in a clockwise direction as viewed from the top, as is clearly indicated by the directional arrow 25 of FIG. 2. This direction of rotation, as indicated by said directional arrow 25, will be referred to herein as "forward," and it should be clearly understood that each of the pushing parts 18A and 18B is bent or deflected upwardly along an angular bend line, as indicated by the corresponding reference numerals 26A and 26B, which are parallel to each other but angularly related to edges of the blade means 17, and which effectively cause each of said pushing parts 18A and 18B to be deflected substantially upwardly from a true horizontal plane and to be twisted so that each of said pushing parts 18A and 18B has the corresponding leading edge 19A or 19B, respectively, positioned at a higher outwardly and upwardly inclined level than the corresponding trailing edge 20A or 20B, respectively. This also acts in a manner such as to cause the corresponding bottom pushing surfaces 22A and 22B to be inclined upwardly and forwardly in the direction of rotation 25 toward the corresponding leading edge 19A or 19B, respectively, and to be inclined upwardly and outwardly in an inclined radial direction away from the longitudinal shaft means 10 whereby to exert an axially downwardly, circumferentially forwardly, and radially outwardly directed force upon the liquid medium L contained within the container, indicated generally at C, and adapted to be mixed during rotation of the blade means 17 by the driving motor 23 of the electric drill 24. This causes positive downward, outward, and forward displacement of the liquid medium L away from the longitudinal shaft 10 in the manner best indicated by the liquid dis-

placement directional arrows shown in FIGS. 2, 4, 6, and 7 and designated by the reference numerals 27A and 27B. This action causes an effective downward suction on an upper central portion of the liquid medium L immediately around the longitudinal shaft means 10 so as to form the conical downwardly extending recess 28 in the body of liquid L when the apparatus is operating and produces a very positive and effective mixing of the liquid L by reason of the rotary displacement action produced by the pushing effect of the pushing portions 18A and 18B described above.

Of course, it should be understood that the entire apparatus may be moved relative to the liquid L in the container C since the apparatus is carried in the user's hands by either or both of the two handle means 29, thus facilitating the complete mixing of all portions of the liquid L. Energization of the motor means 23 is effected by digitally pulling the operating trigger 30 in the customary manner of electric drills and as long as the motor 23 is energized, it will be found that virtually the complete weight of the electric drill 24, the longitudinal shaft means 10, and the blade means 17 will be neutralized by an upwardly directed reactive thrust force produced as a result of the previously-mentioned positive and very powerful displacement of the liquid medium L produced by the upwardly bent and oppositely twisted pushing parts 18A and 18B of the blade means 17. This will have the effect of making the entire apparatus virtually weightless during operation thereof as a mixer and will make it possible to operate the apparatus with virtually no fatigue.

In the exemplary first form of the invention illustrated, the blade means 17 is fastened to the lower end 31 of the longitudinal shaft means 10 by being provided with an interiorly threaded aperture 32, which threadedly engages an exteriorly threaded engagement tip means or portion 33 at the lower end of the shaft means 31, as is most clearly shown in FIG. 3. This structure is extremely simple and remains in fully-engaged relationship because of the fact that the torque exerted on the blade means 17 relative to the longitudinal shaft means 10 during rotation thereof by the driving motor 23 is such as to constantly tighten the interiorly threaded aperture 32 on the threaded tip end portion 33. However, as will be described hereinafter, various other means for engaging the blade means with respect to the shaft means may be provided, and one exemplary modified mounting arrangement is illustrated in FIG. 8.

In the exemplary form of the invention illustrated, the hollow container C takes the form of a hollow cylindrical upwardly open steel drum of an approximately 30-gallon capacity, or the like, although the invention is not limited to use with this specific type of container but may be used with virtually any type of container.

The electric drill 24 is provided with a conventional electric power supply cord 34 and electrical connector plug means 35 for connection to any suitable electric outlet for the purpose of energizing the electric motor means 23 of the electric drill 24 when the trigger means 30 is digitally pulled.

FIG. 8 is a view similar to FIG. 3 but illustrates a modified engagement means and, because it does comprise a modification, reference numerals similar to those of the first form of the invention for corresponding parts are employed, primed, however. In this modification it will be noted that the lower end 31' of the longitudinal shaft means 10' is provided with a longer exteriorly threaded tip end portion 33', which merely passes through the aperture 32' in the center of the blade means 17', and is not threadedly engaged therewith as in the first form of the invention. However, upper and lower threaded nut means 36 are threaded onto said exteriorly threaded tip end portion 33' below and above the apertured portion 32' of the blade means 17' in a position such as to firmly lock said blade means 17' in place on said threaded tip end portion 33' as is clearly illustrated in FIG. 8.

It should be clearly understood that throughout the above description of the apparatus used as a mixer, it is illustrated and described as being vertically oriented and the inclined pushing surfaces 22A and 22B are referred to as being bottom surfaces, and similar positional language of adjective form is used in the specification and claims based upon the vertical orientation of the apparatus. However, as pointed out at the beginning of this application, broadly speaking, it is not limited to use as a mixer nor is it limited to vertical orientation and, therefore, all of said positional language used in the specification and claims is to be broadly construed in the light of the foregoing statement. For example, when the longitudinal shaft means 10 is substantially horizontally positioned, said inclined bottom pushing surfaces 22A and 22B become, in effect, rear inclined pushing surfaces and corresponding changes are to be understood with respect to others of the adjectives employed in connection with the definition of the upwardly or forwardly bent structure of said pushing parts and the twisted configuration thereof so as to be, in effect, axially upwardly and circumferentially forwardly inclined toward the corresponding leading edge and axially rearwardly and circumferentially downwardly inclined toward the corresponding trailing edge. All of this is to be construed as being implicit within the broad meaning of the specific language employed hereinbefore relative to the exemplary vertically oriented mixing apparatus form of the invention.

It should be understood that the figures and the specific description thereof set forth in this application are for the purpose of illustrating the present invention and are not to be construed as limiting the present invention to the precise and detailed specific structure shown in the figures and specifically described hereinbefore. Rather, the real invention is intended to include substantially equivalent constructions embodying the basic teachings and inventive concept of the present invention.

I claim:

1. Power-driven fluid displacement apparatus comprising: longitudinal shaft means having a first portion adapted to be rotatively effectively driven by a driving motor means, said longitudinal shaft means being provided with projecting blade means including at least a first blade portion positioned on one side of said longitudinal shaft means and a second blade portion positioned on the other side thereof in symmetrically balanced relationship and with each of said first and second blade portions having an outer pushing part provided with a leading edge and a trailing edge and an outer tip edge interconnecting said leading and trailing edges and being deflected axially forwardly from a true transverse plane perpendicular to said longitudinal shaft means and twisted so as to have said leading edge positioned along an outwardly and axially forwardly inclined edge line axially forwardly displaced from a similar outwardly and axially forwardly inclined edge line coincident with the corresponding trailing edge, each of said pushing parts having a rear pushing surface inclined axially forwardly and rotatively forwardly in the direction of rotation toward said leading edge and inclined axially forwardly and outwardly in a radial direction away from said longitudinal shaft means whereby to exert an axially rearward, rotatively and circumferentially forward, and radially outward force upon a liquid medium to be mixed during rotation of said blade means by a driving motor means for causing relative displacement of a liquid medium away from said blade means and said longitudinal shaft means and for causing a corresponding reactive forward thrust to be exerted by a relatively displaced liquid medium upon said rotating projecting blade means.

2. Apparatus as defined in claim 1, wherein said blade means is provided with a central fastening aperture and said longitudinal shaft means is provided with engagement means adapted to extend through said aperture and to

cause effective engagement of said blade means with respect to said longitudinal shaft means.

3. Apparatus as defined in claim 1, wherein said blade means is provided with a central fastening aperture and said longitudinal shaft means is provided with engagement means adapted to extend through said aperture and to cause effective engagement of said blade means with respect to said longitudinal shaft means, said engagement means comprising a threaded portion of said longitudinal shaft means and a corresponding effectively threadedly cooperable portion of said blade means around said central fastening aperture of said blade means.

4. Apparatus as defined in claim 1, wherein said blade means is provided with a central fastening aperture and said longitudinal shaft means is provided with engagement means adapted to extend through said aperture and to cause effective engagement of said blade means with respect to said longitudinal shaft means, said engagement means comprising a threaded portion of said longitudinal shaft means and corresponding threaded nut means effectively threadedly cooperable with respect to said threaded portion of said longitudinal shaft means for firmly locking said blade means thereon.

5. Apparatus as defined in claim 1, wherein said blade means is provided with a central fastening aperture and said longitudinal shaft means is provided with engagement means adapted to extend through said aperture and to cause effective engagement of said blade means with respect to said longitudinal shaft means, said engagement means comprising a threaded portion of said longitudinal shaft means and a corresponding pair of threaded nut members effectively threadedly cooperable with respect to said threaded portion of said longitudinal shaft means for firmly locking said blade means between said pair of nut members and on said threaded portion of said shaft means.

6. Apparatus as defined in claim 1, wherein said longitudinal shaft means is normally vertically directed when in use, thus causing said blade means to produce a downward, radially outward, and rotatively forward force upon a liquid medium to be mixed during rotation of said blade means by a driving motor means and, thus, acting to effectively produce substantial displacement and circulation of a liquid medium which is to be mixed and also acting to produce an upwardly axially directed net reactive force tending to substantially neutralize the weight of a driving motor means, the longitudinal shaft means, and the blade means.

7. Apparatus as defined in claim 6, wherein said longitudinal shaft means has an upper engaging end adapted to removably engage a chuck rotatively connected to, and adapted to be driven by, a shaft of a controllably energizable electric motor of a portable hand-operated electric drill.

8. Apparatus as defined in claim 6, including a container of generally cylindrical configuration adapted to contain a liquid medium which is to be mixed by the blade means when rotated within said container.

9. Apparatus as defined in claim 6, wherein said blade means is provided with a central fastening aperture and said longitudinal shaft means is provided with engagement means adapted to extend through said aperture and to cause effective engagement of said blade means with respect to said longitudinal shaft means.

10. Apparatus as defined in claim 6, wherein said blade means is provided with a central fastening aperture and said longitudinal shaft means is provided with engagement means adapted to extend through said aperture and to cause effective engagement of said blade means with respect to said longitudinal shaft means, said engagement means comprising a threaded portion of said longitudinal shaft means and a corresponding effectively threadedly cooperable portion of said blade means around said central fastening aperture of said blade means.

11. Apparatus as defined in claim 6, wherein said blade

9

means is provided with a central fastening aperture and said longitudinal shaft means is provided with engagement means adapted to extend through said aperture and to cause effective engagement of said blade means with respect to said longitudinal shaft means, said engagement means comprising a threaded portion of said longitudinal shaft means and a corresponding pair of threaded nut members effectively threadedly cooperable with respect to said threaded portion of said longitudinal shaft means for firmly locking said blade means between said pair of nut members and on said threaded portion of said shaft means.

10

References Cited

UNITED STATES PATENTS

1,841,435	1/1932	Gibson	-----	259-134
2,659,581	11/1953	Gray	-----	259-134
2,760,762	8/1956	Woodman	-----	259-107
2,799,485	7/1957	Silverman	-----	259-134
3,166,303	1/1965	Chapman	-----	259-135

WALTER A. SCHEEL, *Primary Examiner.*

ROBERT W. JENKINS, *Assistant Examiner.*