

E. P. Baugh,

Guano Drier.

No. 102648.

Patented May 3. 1870.

FIG. 1.

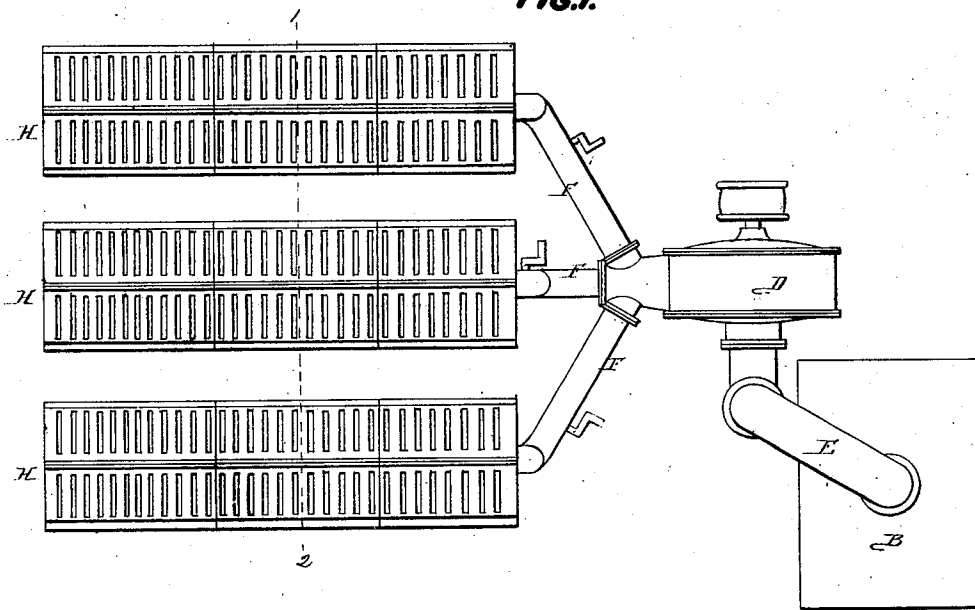

FIG. 2.

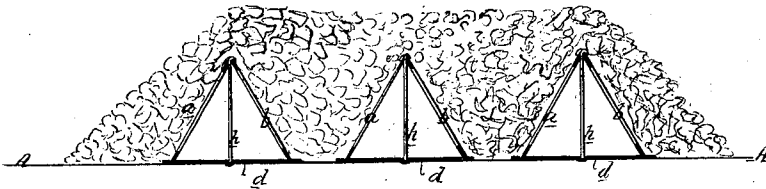

FIG. 4.

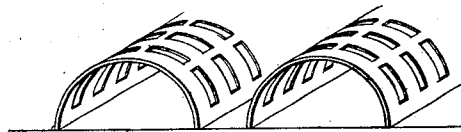
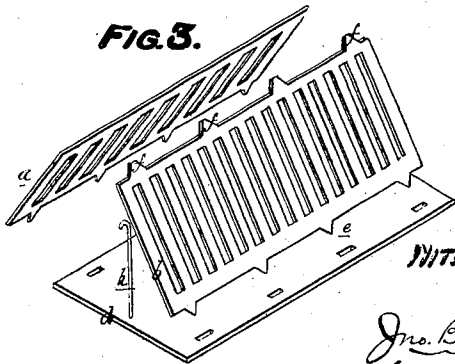

FIG. 3.



WITNESSES,

Jno. B. Harding
Wm. A. Steel

E. P. Baugh
By Geo. A. [unclear]
Howard [unclear]

United States Patent Office.

EDWIN PUGH BAUGH, OF PHILADELPHIA, PENNSYLVANIA.

Letters Patent No. 102,648, dated May 3, 1870.

IMPROVEMENT IN DRYING GUANO.

The Schedule referred to in these Letters Patent and making part of the same.

I, EDWIN PUGH BAUGH, of Philadelphia, county of Philadelphia, State of Pennsylvania, have invented an Improvement in Drying Mineral Guano, &c., of which the following is a specification.

Nature and Objects of the Invention.

My invention consists of certain casings arranged upon a bed or receptacle and constructed as fully described hereafter, so that heated air or gases passed into the casings will be thoroughly and uniformly distributed through a mass of material deposited on the bed.

My invention further consists of mineral guano heated by the direct application of heated gases, as a new product.

Description of the Accompanying Drawing.

Figure 1 is a plan view of apparatus for carrying into effect my improvement in drying mineral guano and other substances.

Figure 2, a transverse vertical section on the line 1-2, fig. 1.

Figure 3, a perspective view of part of the apparatus drawn to an enlarged scale; and

Figure 4, a perspective view of a modification of my invention.

General Description.

The line A represents the surface of a platform or wharf, or of leveled ground, on or near which is situated a furnace, B, and an exhausting and forcing fan, D, or other equivalent apparatus by which the products of combustion may be withdrawn through a suitable pipe, E, from the furnace and forced through pipes F F F.

On the wharf or platform is placed any desired number of grated or perforated casings, which, as shown in figs 2 and 3, are of a triangular sectional form, and are made in sections, each section consisting of the two grated plates *a* and *b* and plain base-plate *d*, the latter having slots for receiving the projections *e e* on the lower edges of the plates *a* and *b*, and one of the latter having at its upper edge projections *f*, adapted to slots in the other, so that the plates can be adjusted to the triangular shape represented, and several sections arranged so as to form long perforated chambers H H H, three such chambers being shown in the present instance, a branch-pipe F from the fan D communicating with the end of each chamber.

Props *h*, fig. 3, may be used as an additional security for maintaining the grated plates *a* and *b* in their proper relative position.

The mineral guano of South Carolina, or, as it is sometimes, termed, rock phosphate, is in its original state impregnated with more or less moisture, and more water is absorbed by it during the necessary washing and so increases its weight as to render its transportation expensive.

My invention has been designed more especially

with the view of affording cheap and ready means of drying this guano in the following manner:

The wet material is deposited on the platform or wharf, so as to completely inclose the grated casings, as best observed on reference to fig. 2, and the products of combustion derived from the furnace B are forced by the fan D, or its equivalent, through the branch-pipes F into the ends of the grated casings, through the perforations of which the products of combustion pass freely, and so permeate the mass of guano in which the casings are imbedded, as to rapidly absorb its moisture, and by thus lessening its weight, reduce it to the best condition for cheap transportation.

Inasmuch as the grated casings extend above the surface of the receptacle or bed on which the guano is deposited, a larger grated surface is obtained, and the gases are more thoroughly distributed through the mass and penetrate the same more readily than if the material was deposited directly on flat gratings.

The accumulated entrails and other offal of animals may also be dried and rendered transportable by the apparatus, and masses of wet coal, ore, and other minerals may be economically dried in the manner described.

I prefer to make the grated or perforated casings in sections and of detachable plates, as shown in fig. 3, so that they can be readily detached from each other, and placed out of the way when not required for use.

These plates may be so hinged together as to be readily adjusted to form one triangular section or to folded together when not required.

It is not essential, however, that the perforated casings should be of a triangular sectional form; semi-cylindrical perforated plates of metal may be used, as shown in fig. 4, and so arranged as to rest with their edges on plain plates.

Heated air may be forced into the perforated casings, but I prefer the employment of the products of combustion especially in drying fish and other offal.

Claims.

1. A series of grated casings arranged upon and extending above the surface of a bed or receptacle for guano or other material, and communicating with flues for passage of heated gases, substantially as described.

2. Mineral guano treated by the direct application of heated gases, as a new product.

In testimony whereof I have signed my name to this specification in the presence of two subscribing witnesses.

EDWIN P. BAUGH.

Witnesses:

F. B. RICHARDS,
HARRY SMITH.