

A. W. REDDERSEN & F. G. BORG.

METAL SASH CONSTRUCTION.

APPLICATION FILED OCT. 12, 1911.

1,069,290.

Patented Aug. 5, 1913.

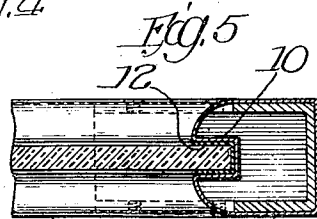
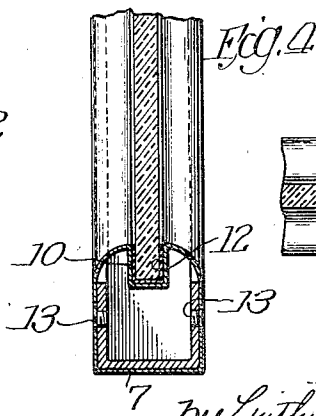
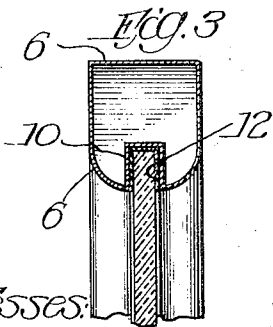
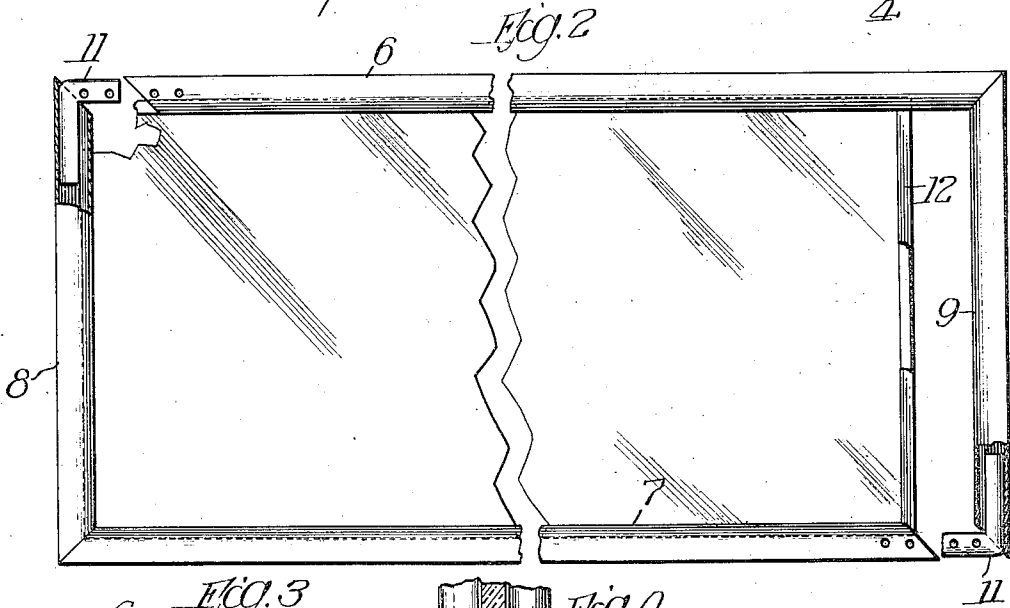
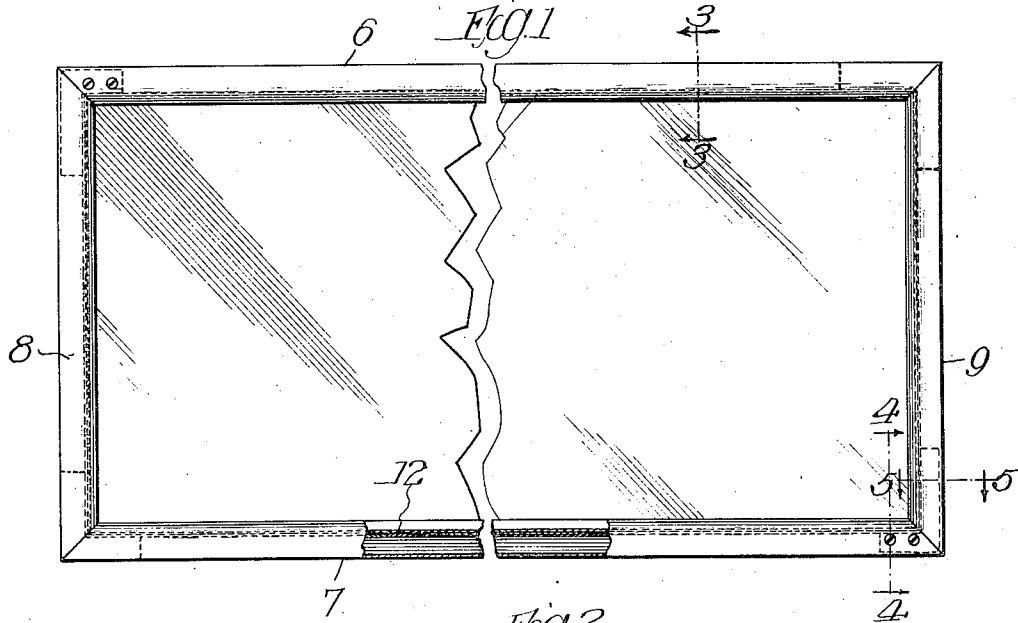

Witnesses:
H. B. Barnett
E. O. McNeil

Inventors
Arthur W. Reddersen
Frederick G. Borg
By Luther C. Bell & Fuller Attys

UNITED STATES PATENT OFFICE.

ARTHUR W. REDDERSEN AND FREDERICK G. BORG, OF CHICAGO, ILLINOIS, ASSIGNORS
TO FORSYTH BROTHERS COMPANY, OF CHICAGO, ILLINOIS, A CORPORATION OF
ILLINOIS.

METAL SASH CONSTRUCTION.

1,069,290.

Specification of Letters Patent.

Patented Aug. 5, 1913.

Application filed October 12, 1911. Serial No. 654,284.

To all whom it may concern:

Be it known that we, ARTHUR W. REDDERSEN and FREDERICK G. BORG, citizens of the United States, residing at Chicago, in the county of Cook and State of Illinois, have invented certain new and useful Improvements in Metal Sash Construction, of which the following is a specification.

Our invention relates to means for securely mounting the glass in metal sash.

The first part of our improvement relates to a novel method of mounting the glass in the sash and this we do by so constructing the sash that it can be separated at its corners and preferably its diagonal corners. The glass in the latter case is slipped into the sash groove of one-half of the sash and the other half is then engaged over the edge of the glass and by a very slight movement the corners may be brought together and secured.

Another feature of our invention relates to certain metal reinforcements in the corners of the sash.

In the accompanying drawings Figure 1 is a broken elevation of a sash embodying our invention, the corners thereof being joined as in service. Fig. 2 is a similar view showing the glass partially in place and the sections of the sash slightly separated. Figs. 3, 4 and 5 are transverse sections on the lines 3-3, 4-4 and 5-5, respectively.

In the drawings 6 and 7 represent respectively, the top and bottom sash bars, or rails and 8 and 9, respectively, the stiles or side members of the sash. The top and bottom sash bars 6 and 7, and the stiles 8 and 9, are of the form shown in the sectional view Fig. 3 being provided with a glass groove 10 which is formed either by drawing or pressing in the usual manner. The bottom bar 7 is connected to the side stile by a corner piece 11. The vertical member of the corner piece is of rectangular form and is connected thereto by sweating. As shown particularly in Fig. 2 one of these joint pieces is used at the junction of the lower sash bar with the right-hand stile, while at the upper diagonal opposite corner a similar joint piece is used. The vertical members are fixedly secured to the stiles 8

and 9 while the horizontal members are adapted to be attachably connected to the upper and lower sash bars 6 and 7 by screws. In order to prevent rattling and avoid any space through which air or dust can pass we employ a rubber packing 12 U-shaped in cross section which embraces the margins of the sheet of glass.

Assuming that the parts are assembled as shown in Fig. 2; the corner pieces being secured respectively to the stiles 8 and 9, and the sheet of glass being in place, and the part 6 being adjacent the edge of the glass, a slight movement only of the top bar 6 and the stile 9 toward the part 8 is required to effect the telescoping of the horizontal members of the corner pieces with the top and bottom sash bars. During such movement the margin of the glass will have seated within the groove in the stiles 6 and 9. The rubber packing is preferably applied to the sheet of glass around all of its margins before the parts are assembled.

It will be noted that the construction above described entirely avoids the use of glazing strips or extensive sliding of the glass for the purpose of assembling the glass in the frame.

If the rubber cushion be applied to the glass before the parts of the metal sash are united these latter are forced over the rubber cushions transversely to their length, thus avoiding injurious displacement or wrinkling of the latter.

We claim:

1. A metal sash having top and bottom bars and side stiles provided with grooves on their inner edges affording seats for the glass, the top and bottom bars being permanently connected respectively with one of the side stiles thus forming two rigid sections adapted to be applied to the sash by a movement toward each other, and means for connecting the ends of the sections at diagonally opposite corners of the sash, substantially as described.

2. A metal sash composed of top, bottom and side members each of hollow form and provided with a groove in its inner edge affording a seat for the glass, the top and bottom members being permanently connected respectively to one only of the side

members thus forming two rigid L-shaped sections adapted to be applied to the glass by a movement toward each other, and means for connecting said sections at diagonally opposite corners of the sash, said connecting means being secured respectively to one of said sections and adapted to telescope with the other section, substantially as described.

ARTHUR W. REDDERSEN.
FREDERICK G. BORG.

Witnesses:

S. ELIZABETH BRANDT,
MARGARET ANDERSON.
