



(51) International Patent Classification:

F01D 25/00 (2006.01) F02C 3/04 (2006.01)  
F02C 7/36 (2006.01)

(21) International Application Number:

PCT/US2013/024909

(22) International Filing Date:

6 February 2013 (06.02.2013)

(25) Filing Language:

English

(26) Publication Language:

English

(30) Priority Data:

13/366,948 6 February 2012 (06.02.2012) US

(71) Applicant: UNITED TECHNOLOGIES CORPORATION [US/US]; 1 Financial Plaza, Hartford, Connecticut 06101 (US).

(72) Inventor: COFFIN, James, B.; 35 Hobson Avenue, Windsor, Connecticut 06095 (US).

(74) Agent: BALICH, Garrett, W.; O'Shea Getz P.C. c/o CPA Global, P.O. Box 52050, Minneapolis, MN 55402 (US).

(81) Designated States (unless otherwise indicated, for every kind of national protection available): AE, AG, AL, AM,

AO, AT, AU, AZ, BA, BB, BG, BH, BN, BR, BW, BY, BZ, CA, CH, CL, CN, CO, CR, CU, CZ, DE, DK, DM, DO, DZ, EC, EE, EG, ES, FI, GB, GD, GE, GH, GM, GT, HN, HR, HU, ID, IL, IN, IS, JP, KE, KG, KM, KN, KP, KR, KZ, LA, LC, LK, LR, LS, LT, LU, LY, MA, MD, ME, MG, MK, MN, MW, MX, MY, MZ, NA, NG, NI, NO, NZ, OM, PA, PE, PG, PH, PL, PT, QA, RO, RS, RU, RW, SC, SD, SE, SG, SK, SL, SM, ST, SV, SY, TH, TJ, TM, TN, TR, TT, TZ, UA, UG, US, UZ, VC, VN, ZA, ZM, ZW.

(84) Designated States (unless otherwise indicated, for every kind of regional protection available): ARIPO (BW, GH, GM, KE, LR, LS, MW, MZ, NA, RW, SD, SL, SZ, TZ, UG, ZM, ZW), Eurasian (AM, AZ, BY, KG, KZ, RU, TJ, TM), European (AL, AT, BE, BG, CH, CY, CZ, DE, DK, EE, ES, FI, FR, GB, GR, HR, HU, IE, IS, IT, LT, LU, LV, MC, MK, MT, NL, NO, PL, PT, RO, RS, SE, SI, SK, SM, TR), OAPI (BF, BJ, CF, CG, CI, CM, GA, GN, GQ, GW, ML, MR, NE, SN, TD, TG).

Published:

— with international search report (Art. 21(3))

(54) Title: TURBINE ENGINE SHAFT COUPLING

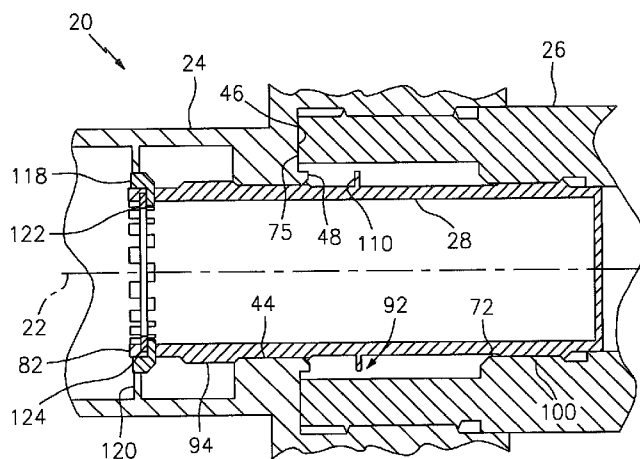

FIG. 1

(57) Abstract: A turbine engine shaft includes a first sub-shaft, a second sub-shaft and a tie shaft. A first bearing surface of the first sub-shaft axially engages a second bearing surface of the second sub-shaft. The tie shaft includes an intermediate tie shaft segment connected axially between a first tie shaft segment and a second tie shaft segment. The first tie shaft segment includes a first threaded tie shaft surface that is mated with a first threaded shaft surface of the first sub-shaft. The second tie shaft segment includes a second threaded tie shaft surface that is mated with a second threaded shaft surface of the second sub-shaft. The tie shaft also includes a sub-shaft bumper stop extending radially from the intermediate tie shaft segment to a bumper stop distal end, which has a radius that is greater than a radius the first and/or second threaded shaft surfaces.

WO 2013/119645 A1

## TURBINE ENGINE SHAFT COUPLING

Applicant hereby claims priority to U.S. Patent Application No. 13/366,948 filed February 6, 2012, the disclosure of which is herein incorporated by reference.

## BACKGROUND OF THE INVENTION

## 1. Technical Field

[0001] The present invention relates generally to a turbine engine and, in particular, to a shaft coupling for a turbine engine shaft.

## 2. Background Information

[0002] A typical gas turbine engine may have a fan section, a compressor section, a combustor section and a turbine section that are sequentially arranged along an axis. The engine may include one or more turbine engine shafts that axially connect one or more rotors included in the fan section and/or the compressor section with one or more rotors included in the turbine section. Each shaft may include a plurality of sub-shafts. Adjacent ends of the sub-shafts may be connected together utilizing a tie-shaft. Properly aligning threads of the tie shaft with corresponding threads of the sub-shafts, however, may be difficult (e.g., require tedious alignment measurements) and time consuming.

## SUMMARY OF THE DISCLOSURE

[0003] According to an aspect of the invention, a turbine engine shaft includes a first sub-shaft, a second sub-shaft and a tie shaft. The first sub-shaft includes a radial inner first threaded shaft surface that extends along an axis, and a first bearing surface that extends radially inward towards the first threaded shaft surface. The second sub-shaft includes a radial inner second threaded shaft surface that extends along the axis, and a second bearing surface that extends radially inward towards the second threaded shaft surface, where the second bearing surface axially engages the first bearing surface. The tie shaft includes an intermediate tie shaft segment connected axially between a first tie shaft segment and a second tie shaft segment. The first tie shaft segment includes a radial outer first threaded tie shaft surface that is mated with the first threaded shaft surface. The second tie shaft segment includes a radial outer threaded second tie shaft surface that is mated with the second threaded shaft surface. The tie shaft also includes

a sub-shaft bumper stop that extends radially from the intermediate tie shaft segment to a bumper stop distal end, which has a radius that is greater than a radius of the first and/or second threaded shaft surfaces.

[0004] In an embodiment, the first sub-shaft also includes a bumper stop bearing surface that extends radially inward towards the first shaft surface. The bumper stop bearing surface is engaged the sub-shaft bumper stop during a first turbine engine shaft assembly step, and is spatially separated from the sub-shaft bumper stop during a subsequent second turbine engine shaft assembly step.

[0005] In an embodiment, the first sub-shaft also includes a bumper stop bearing surface that extends radially inward towards the first shaft surface. The first threaded shaft surface extends axially towards the bumper stop bearing surface from a first shaft surface end to a second shaft surface end, where the first shaft surface end is located a first axial distance from the bumper stop bearing surface. The first threaded tie shaft surface extends axially away from sub-shaft bumper stop from a first tie shaft surface end to a second tie shaft surface end, where the first tie shaft surface end is located a second axial distance from the sub-shaft bumper stop that is less than the first axial distance. In one embodiment, the first bearing surface is arranged axially between the bumper stop bearing surface and the first shaft surface end. In another embodiment, the first bearing surface includes the bumper stop bearing surface.

[0006] In an embodiment, the first threaded shaft surface has a first thread pitch, and the second threaded shaft surface has a second thread pitch that is different than the first thread pitch. In one embodiment, the second thread pitch is finer than the first thread pitch.

[0007] In an embodiment, the radius of the first threaded shaft surface is substantially equal to the radius of the second threaded shaft surface.

[0008] In an embodiment, the first sub-shaft also includes a radial inner first splined shaft surface that extends along the axis. The first bearing surface is arranged radially between the first threaded shaft surface and the first splined shaft surface. The second sub-shaft also includes a radial outer second splined shaft surface. The radial outer second splined shaft surface is mated with the first splined shaft surface, and is arranged axially between the second threaded shaft surface and the second bearing surface. In one embodiment, the first splined shaft surface and the second splined shaft surface are axially aligned with the sub-shaft bumper stop.

[0009] In an embodiment, the sub-shaft bumper stop includes an annular flange. In other embodiments, the sub-shaft bumper stop includes a plurality of protrusions that are arranged circumferentially around the intermediate tie shaft segment. In other embodiments, the sub-shaft bumper stop includes a threaded nut mated with a threaded, radial outer tie-shaft surface of the intermediate tie shaft segment. In still other embodiments, the sub-shaft bumper stop includes a fastener that is connected to the intermediate tie shaft segment.

[0010] The foregoing features and the operation of the invention will become more apparent in light of the following description and the accompanying drawings.

#### BRIEF DESCRIPTION OF THE DRAWINGS

[0011] FIG. 1 is a partial sectional illustration of a coupling for a turbine engine shaft;

[0012] FIG. 2 is a top-half, partial sectional illustration of a first sub-shaft included in the turbine engine shaft illustrated in FIG. 1;

[0013] FIG. 3 is a top-half, partial sectional illustration of a second sub-shaft included in the turbine engine shaft illustrated in FIG. 1;

[0014] FIG. 4 is a top-half, partial sectional illustration of a tie shaft included in the turbine engine shaft illustrated in FIG. 1;

[0015] FIG. 5 is a flow diagram of a method for assembling the turbine engine shaft;

[0016] FIG. 6 is a top-half, partial sectional illustration of the first sub-shaft and the tie shaft during an assembly step;

[0017] FIG. 7 is a top-half, partial sectional illustration of the first sub-shaft, the second sub-shaft and the tie shaft during another assembly step;

[0018] FIG. 8 is a cross-sectional illustration of the tie shaft included in the turbine engine shaft illustrated in FIG. 1;

[0019] FIG. 9 is a cross-sectional illustration of another tie shaft;

[0020] FIG. 10 is a top-half, partial sectional illustration of another turbine engine shaft;  
and

[0021] FIG. 11 is a top-half, partial sectional illustration of another turbine engine shaft.

#### DETAILED DESCRIPTION OF THE INVENTION

[0022] FIG. 1 illustrates a coupling for a turbine engine shaft 20 that may be configured in, for example, a gas turbine engine, a gas turbine power plant, a steam turbine engine, etc. The turbine engine shaft 20 extends along and is rotatable about an axis 22. The turbine engine shaft 20 may include a turbine engine first sub-shaft 24, a turbine engine second sub-shaft 26, and a turbine engine tie shaft 28.

[0023] FIG. 2 illustrates a top-half portion of the first sub-shaft 24. The first sub-shaft 24 includes a (e.g., tubular) first sub-shaft sidewall 30 that extends axially to a first sub-shaft end 32. The first sub-shaft 24 may also include one or more sub-shaft segments such as, for example, a first intermediate shaft segment 34, a first threaded shaft segment 36, and a first splined shaft segment 38. The first intermediate shaft segment 34 may be configured, for example, to connect to one or more turbine engine rotors (not shown).

[0024] The first threaded shaft segment 36 extends axially between a first threaded shaft segment end 40 connected to, for example, the first intermediate shaft segment 34 and a second threaded shaft segment end 42. The first threaded shaft segment 36 includes a radial inner first threaded shaft surface 44, a first bearing surface 46, and a bumper stop bearing surface 48. The first threaded shaft surface 44 may extend axially from a first shaft surface end 50 at, for example, the first threaded shaft segment end 40 to a second shaft surface end 52 at, for example, the second threaded shaft segment end 42. The first threaded shaft surface 44 is configured with a first (e.g., right-hand) thread pitch and a first radius 54. The first bearing surface 46 extends radially inward towards the first threaded shaft surface 44, and may be axially recessed into the second threaded shaft segment end 42. The bumper stop bearing surface 48 is arranged at the second threaded shaft segment end 42, and may extend radially inward to the first threaded shaft surface 44. The bumper stop bearing surface 48 is located a first axial distance 56 from the first shaft surface end 50.

[0025] The first splined shaft segment 38 may extend axially from the first threaded shaft segment 36 (e.g., the first bearing surface 46) to the first sub-shaft end 32. The first splined shaft segment 38 includes a radial inner first splined shaft surface 58 that extends along the axis 22. The first splined shaft surface 58 may be arranged axially between the first bearing surface 46 and the first sub-shaft end 32.

[0026] FIG. 3 illustrates a top-half portion of the second sub-shaft 26. The second sub-shaft 26 includes a (e.g., tubular) first sub-shaft sidewall 60 that extends axially to a second sub-

shaft end 62. The second sub-shaft 26 may also include one or more sub-shaft segments such as, for example, a second intermediate shaft segment 64, a second threaded shaft segment 66, and a second splined shaft segment 68. The second intermediate shaft segment 64 may be configured, for example, to connect to one or more turbine engine rotors (not shown).

[0027] The second threaded shaft segment 66 may extend axially from the second intermediate shaft segment 64 to a threaded shaft segment end 70. The second threaded shaft segment 66 includes a radial inner second threaded shaft surface 72 that extends along the axis 22. The second threaded shaft surface 72 may extend axially from the threaded shaft segment end 70 (e.g., partially) towards the second intermediate shaft segment 64. The second threaded shaft surface 72 is configured with a second (e.g., left-hand) thread pitch and a second radius 74. The second thread pitch may be different (e.g., finer) than the first thread pitch, and the second radius 74 may be substantially equal to the first radius 54 (see FIG. 2).

[0028] The second splined shaft segment 68 may extend axially from the threaded shaft segment end 70 to a second bearing surface 75 at the second sub-shaft end 62. The second splined shaft segment 68 extends radially between a radial inner surface 76 and a radial outer second splined shaft surface 78. The radial inner surface 76 is configured with a third radius 80 that is greater than the first radius 54 (see FIG. 2) and the second radius 74. The second splined shaft surface 78 extends along the axis 22, and may be arranged between the threaded shaft segment end 70 and the second sub-shaft end 62.

[0029] FIG. 4 illustrates a top-half portion of the tie shaft 28. The tie shaft 28 includes a (e.g., tubular) tie shaft sidewall 81 that extend axially between a (e.g., castellated) first tie shaft end 82 and an endwall at a second tie shaft end 84. The tie shaft 28 also includes a threaded first tie shaft segment 86, a threaded second tie shaft segment 88, an intermediate tie shaft segment 90 and a sub-shaft bumper stop 92. The first tie shaft segment 86 may extend axially from the first tie shaft end 82 to the intermediate tie shaft segment 90. The first tie shaft segment 86 includes a radial outer first threaded tie shaft surface 94. The first threaded tie shaft surface 94 may extend axially from the intermediate tie shaft segment 90 at a first tie shaft surface end 96 to a second tie shaft surface end 98. The second tie shaft segment 88 includes a radial outer second threaded tie shaft surface 100. The second threaded tie shaft surface 100 may extend axially from the intermediate tie shaft segment 90 at a first tie shaft surface end 102 to a second tie shaft surface

end 104. The intermediate tie shaft segment 90 is connected axially between the first tie shaft segment 86 and the second tie shaft segment 88.

[0030] The sub-shaft bumper stop 92 extends radially from the intermediate tie shaft segment 90 to a bumper stop distal end 106. The bumper stop distal end 106 is configured with a fourth radius 108 that is greater than the first radius 54 (see FIG. 2) and/or the second radius 74 (see FIG. 3), and is less than the third radius 80 (see FIG. 3). The sub-shaft bumper stop 92 also extends axially between a first bumper stop surface 110 and a second bumper stop surface 112. The first bumper stop surface 110 is located a second axial distance 114 from the first tie shaft surface end 96 that may be less than the first axial distance 56 (see FIG. 2). The second bumper stop surface 112 is located a third axial distance 116 from the first tie shaft surface end 102.

[0031] FIG. 5 is a flow diagram of a method for assembling the turbine engine shaft 20. Referring to FIGS. 5 and 6, in step 500, the first threaded tie shaft surface 94 is mated with (e.g., threaded into) the first threaded shaft surface 44. In step 502, the tie shaft 28 is rotated in a first (e.g., clockwise) direction relative to the first sub-shaft 24 until, for example, the bumper stop bearing surface 48 axially engages with (e.g., contacts) the first bumper stop surface 110. In this manner, the sub-shaft bumper stop 92 may be utilized to set depth of pre-engagement of the first threaded tie shaft surface 94 with the first threaded shaft surface 44 without, for example, alignment measurements. Referring to FIGS. 5 and 7, in step 504, the first splined shaft surface 58 is mated with the second splined shaft surface 78. Referring to FIGS. 5 and 1, in step 506, the second threaded tie shaft surface 100 is mated with the second threaded shaft surface 72. In step 508, the tie shaft 28 is rotated in a second (e.g., counter clockwise) direction relative to the first sub-shaft 24 and the second sub-shaft 26 until, for example, the first bearing surface 46 axially engages with the second bearing surface 75, which spatially separates the bumper stop bearing surface 48 from the first bumper stop surface 110. In this manner, the sub-shaft bumper stop 92 may be utilized during the turbine engine shaft 20 assembly to axially align (i) the first threaded tie shaft surface 94 with the first threaded shaft surface 44 and/or (ii) the second threaded tie shaft surface 100 with the second threaded shaft surface 72 without, for example, alignment measurements or other installation gauging. The sub-shaft bumper stop 92 therefore may reduce shaft assembly time and provide more repeatable and narrower assembly tolerances.

[0032] In step 510, a keyed (e.g., castellated) washer 118 may be mated with the first tie shaft end 82 and a (e.g., castellated) annular flange 120 extending radially inwards from the first

intermediate shaft segment 34 to prevent the tie shaft 28 from rotating relative to the first sub-shaft 24 and the second sub-shaft 26 during turbine engine operation. In step 512, a retaining ring 122 may be seated within tie shaft notches 124 (see also FIG. 4) to hold the keyed washer 118 in position.

[0033] The sub-shaft bumper stop 92 may be implemented with various different configurations, and may be formed integral to or discrete from the intermediate tie shaft segment 90. In one embodiment, for example as illustrated in FIG. 8, the sub-shaft bumper stop 92 may be configured as a (e.g., cylindrical) annular flange 126 that extends circumferentially around the intermediate tie shaft segment 90. In another embodiment, for example as illustrated in FIG. 9, the sub-shaft bumper stop 92 may include one or more radial protrusions 128 that are (e.g., discretely and uniformly) arranged circumferentially around the intermediate tie shaft segment 90. In still another embodiment, for example as illustrated in FIG. 10, the sub-shaft bumper stop 92 may include at least one fastener 130 (e.g., a pin, screw, etc.) that extends through a corresponding aperture 132 in the intermediate tie shaft segment 90. In still another embodiment, for example as illustrated in FIG. 11, the sub-shaft bumper stop 92 may include a threaded nut 134 mated with a threaded, radial outer tie-shaft surface 136 of the intermediate tie shaft segment 90. The present invention, however, is not intended to be limited to any of the aforesaid sub-shaft bumper stop configurations.

[0034] In some embodiments, for example as illustrated in FIGS. 10 and 11, the first bearing surface 46 may be configured with the bumper stop bearing surface 48. In other embodiments, for example, the first sub-shaft 24 and the second sub-shaft 26 may be connected together with one or more fasteners rather than the splined connection illustrated in the drawings. A person of ordinary skill in the art will recognize that the first sub-shaft 24 and/or the second sub-shaft 26 may have various alternate configurations depending upon the particular application and/or design constraints. The present invention, therefore, is not intended to be limited to any particular sub-shaft configuration.

[0035] While various embodiments of the present invention have been disclosed, it will be apparent to those of ordinary skill in the art that many more embodiments and implementations are possible within the scope of the invention. Accordingly, the present invention is not to be restricted except in light of the attached claims and their equivalents.

What is claimed is:

1. A turbine engine shaft, comprising:

a first sub-shaft comprising a radial inner first threaded shaft surface that extends along an axis, and a first bearing surface that extends radially inward towards the first threaded shaft surface;

a second sub-shaft comprising a radial inner second threaded shaft surface that extends along the axis, and a second bearing surface that extends radially inward towards the second threaded shaft surface, the second bearing surface axially engaging the first bearing surface; and

a tie shaft comprising

an intermediate tie shaft segment connected axially between a first tie shaft segment and a second tie shaft segment, the first tie shaft segment comprising a radial outer first threaded tie shaft surface mated with the first threaded shaft surface, and the second tie shaft segment comprising a radial outer threaded second tie shaft surface mated with the second threaded shaft surface; and

a sub-shaft bumper stop extending radially from the intermediate tie shaft segment to a bumper stop distal end that comprises a radius that is greater than a radius of at least one of the first threaded shaft surface and the second threaded shaft surface.

2. The shaft of claim 1, wherein

the first sub-shaft further comprises a bumper stop bearing surface that extends radially inward towards the first shaft surface; and

the bumper stop bearing surface engages the sub-shaft bumper stop during a first turbine engine shaft assembly step, and is spatially separated from the sub-shaft bumper stop during a second turbine engine shaft assembly step that is subsequent to the first turbine engine shaft assembly step.

3. The shaft of claim 1, wherein

the first sub-shaft further comprises a bumper stop bearing surface that extends radially inward towards the first shaft surface;

the first threaded shaft surface extends axially towards the bumper stop bearing surface from a first shaft surface end to a second shaft surface end, and the first shaft surface end is located a first axial distance from the bumper stop bearing surface; and

the first threaded tie shaft surface extends axially away from sub-shaft bumper stop from a first tie shaft surface end to a second tie shaft surface end, and the first tie shaft surface end is located a second axial distance from the sub-shaft bumper stop that is less than the first axial distance.

4. The shaft of claim 3, wherein the first bearing surface is arranged axially between the bumper stop bearing surface and the first shaft surface end.
5. The shaft of claim 3, wherein the first bearing surface comprises the bumper stop bearing surface.
6. The shaft of claim 1, wherein the first threaded shaft surface comprises a first thread pitch, and the second threaded shaft surface comprises a second thread pitch that is different than the first thread pitch.
7. The shaft of claim 6, wherein the second thread pitch is finer than the first thread pitch.
8. The shaft of claim 1, wherein the radius of the first threaded shaft surface is substantially equal to the radius of the second threaded shaft surface.
9. The shaft of claim 1, wherein  
the first sub-shaft further comprises a radial inner first splined shaft surface that extends along the axis;  
the first bearing surface is arranged radially between the first threaded shaft surface and the first splined shaft surface; and  
the second sub-shaft further comprises a radial outer second splined shaft surface that is mated with the first splined shaft surface, and that is arranged axially between the second threaded shaft surface and the second bearing surface.

10. The shaft of claim 9, wherein the first splined shaft surface and the second splined shaft surface are axially aligned with the sub-shaft bumper stop.
11. The shaft of claim 1, wherein the sub-shaft bumper stop comprises an annular flange.
12. The shaft of claim 1, wherein the sub-shaft bumper stop comprises a plurality of protrusions that are arranged circumferentially around the intermediate tie shaft segment.
13. The shaft of claim 1, wherein the sub-shaft bumper stop comprises a threaded nut mated with a threaded, radial outer tie-shaft surface of the intermediate tie shaft segment.
14. The shaft of claim 1, wherein the sub-shaft bumper stop comprises a fastener that is connected to the intermediate tie shaft segment.



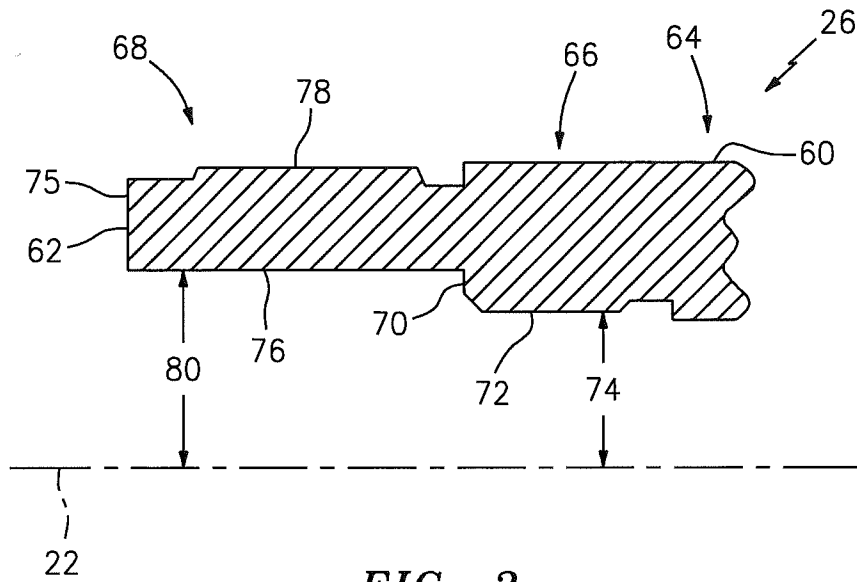

FIG. 3

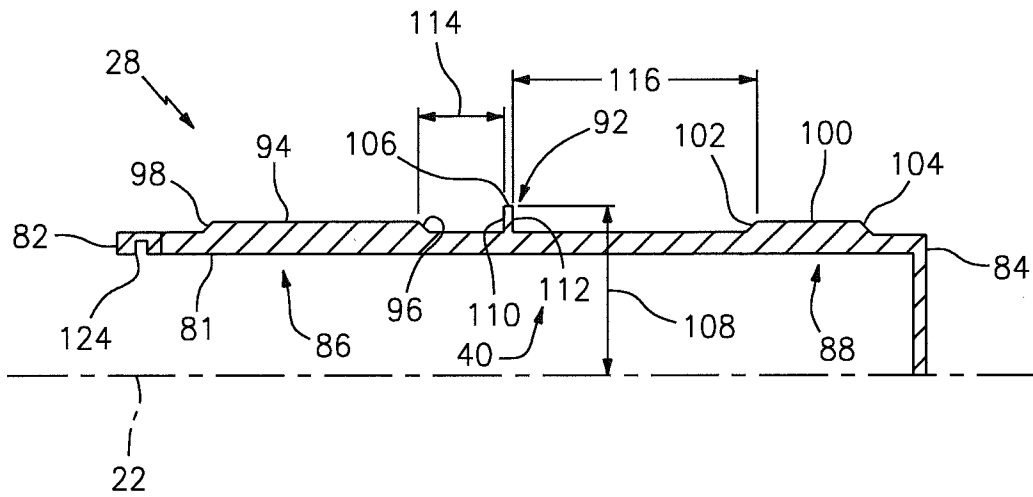

FIG. 4

3/5

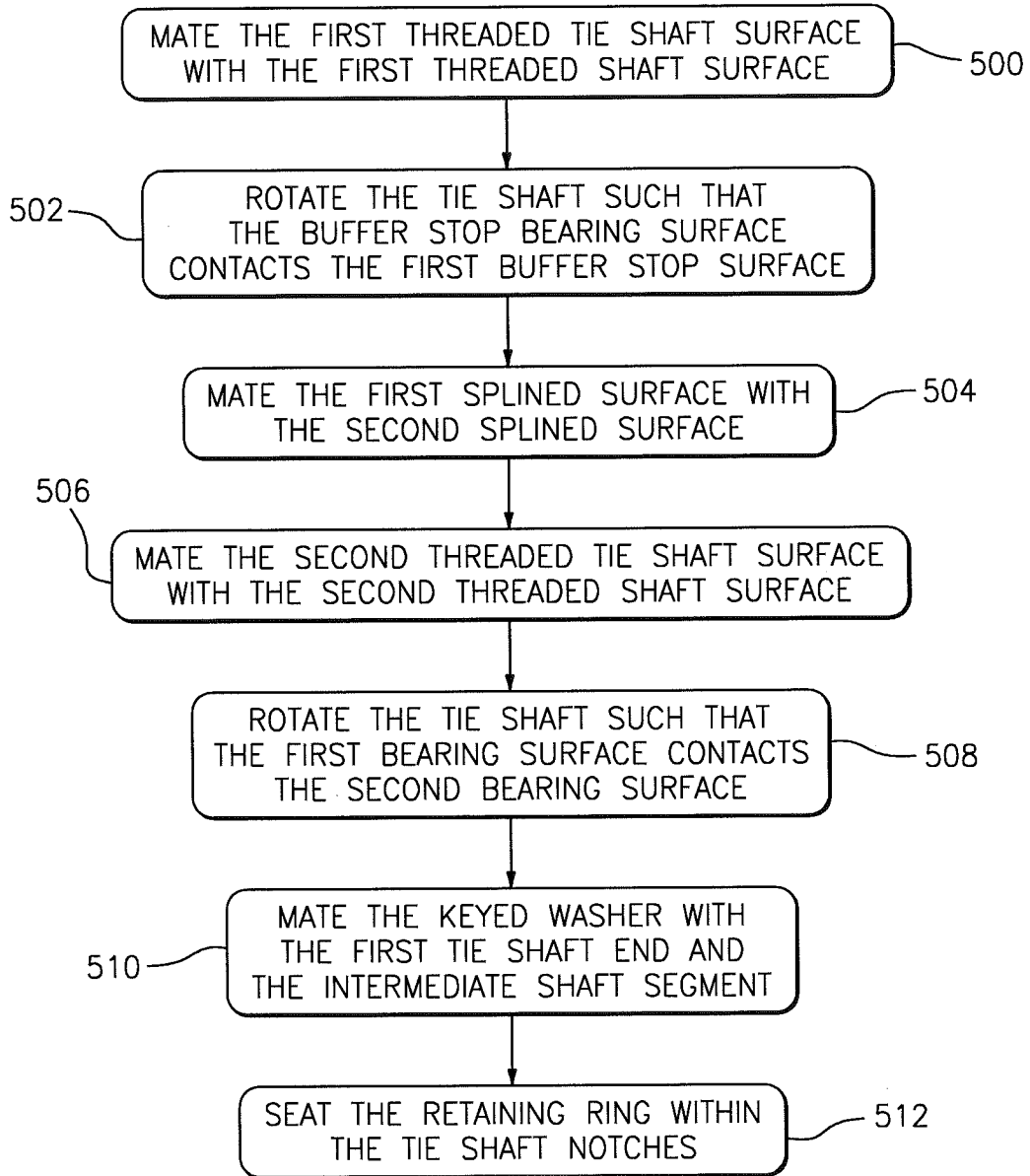

FIG. 5

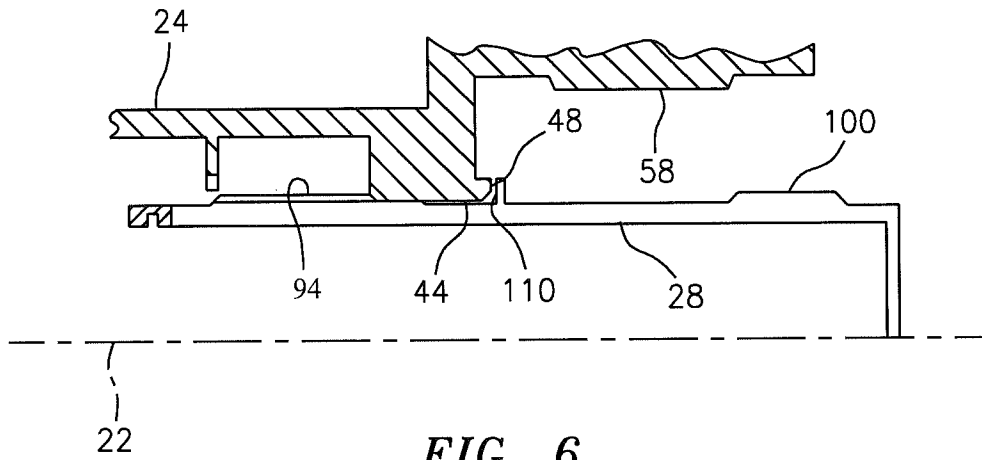

FIG. 6

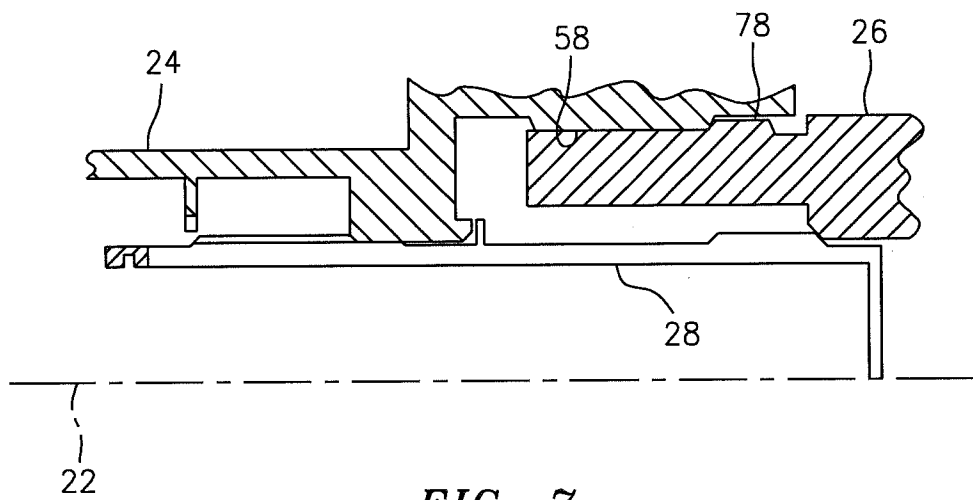
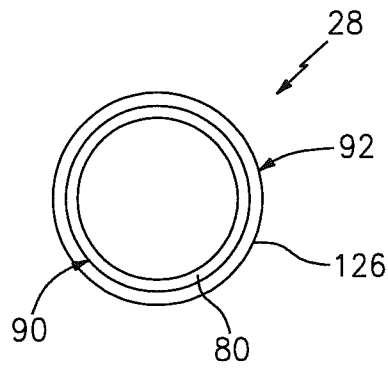
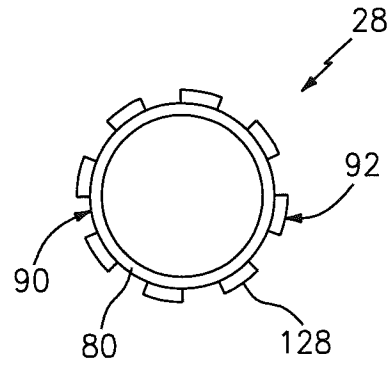

FIG. 7



**FIG. 8**



**FIG. 9**

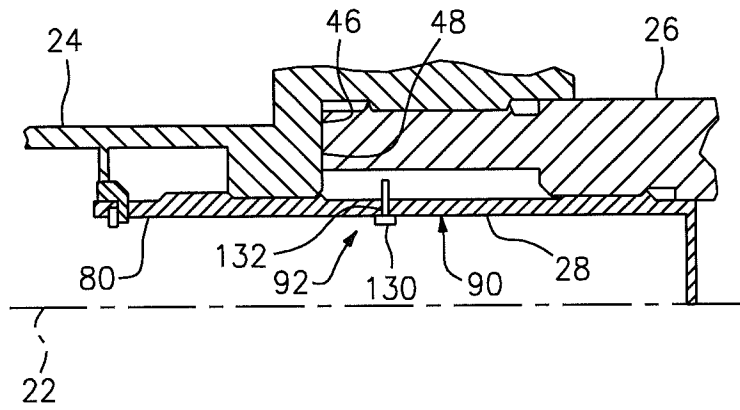

**FIG. 10**

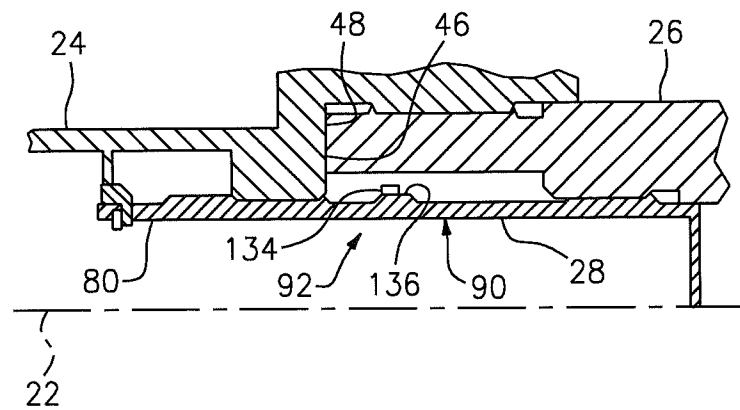

**FIG. 11**

## INTERNATIONAL SEARCH REPORT

International application No.  
**PCT/US2013/024909****A. CLASSIFICATION OF SUBJECT MATTER*****F01D 25/00(2006.01)i, F02C 7/36(2006.01)i, F02C 3/04(2006.01)i***

According to International Patent Classification (IPC) or to both national classification and IPC

**B. FIELDS SEARCHED**

Minimum documentation searched (classification system followed by classification symbols)

F01D 25/00; B23P 15/04; F02C 7/20; F01D 5/10; F02C 3/06; F02C 7/00; F04D 29/20

Documentation searched other than minimum documentation to the extent that such documents are included in the fields searched

Korean utility models and applications for utility models

Japanese utility models and applications for utility models

Electronic data base consulted during the international search (name of data base and, where practicable, search terms used)

eKOMPASS(KIPO internal) &amp; Keywords: gas, turbine, engine, shaft, coupling, connect, mount, tie, and surface

**C. DOCUMENTS CONSIDERED TO BE RELEVANT**

Category*	Citation of document, with indication, where appropriate, of the relevant passages	Relevant to claim No.
A	US 2011-0223026 A1 (BENJAMIN et al.) 15 September 2011 See abstract; paragraphs [0013]-[0015]; figures 1,2.	1-14
A	US 2010-0158699 A1 (MAKUSZEWSKI, JERZY) 24 June 2010 See abstract; paragraphs [0014], [0015]; figure 3.	1-14
A	US 2011-0146298 A1 (REINHARDT et al.) 23 June 2011 See abstract; paragraph [0010]; figure 2.	1-14
A	US 4,664,599 A (ROBBINS et al.) 12 May 1987 See abstract; column 3, lines 14-29; figure 1.	1-14
A	US 4,973,221 A (ANDERSON et al.) 27 November 1990 See abstract; column 3, lines 23-38; figure 2.	1-14

 Further documents are listed in the continuation of Box C. See patent family annex.

\* Special categories of cited documents:

"A" document defining the general state of the art which is not considered to be of particular relevance

"E" earlier application or patent but published on or after the international filing date

"L" document which may throw doubts on priority claim(s) or which is cited to establish the publication date of citation or other special reason (as specified)

"O" document referring to an oral disclosure, use, exhibition or other means

"P" document published prior to the international filing date but later than the priority date claimed

"T" later document published after the international filing date or priority date and not in conflict with the application but cited to understand the principle or theory underlying the invention

"X" document of particular relevance; the claimed invention cannot be considered novel or cannot be considered to involve an inventive step when the document is taken alone

"Y" document of particular relevance; the claimed invention cannot be considered to involve an inventive step when the document is combined with one or more other such documents, such combination being obvious to a person skilled in the art

"&amp;" document member of the same patent family

Date of the actual completion of the international search

13 May 2013 (13.05.2013)

Date of mailing of the international search report

**14 May 2013 (14.05.2013)**

Name and mailing address of the ISA/KR

Korean Intellectual Property Office  
189 Cheongsa-ro, Seo-gu, Daejeon Metropolitan  
City, 302-701, Republic of Korea

Facsimile No. 82-42-472-7140

Authorized officer

HAN, Joong Sub

Telephone No. 82-42-481-5606

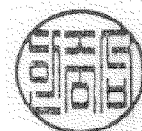

**INTERNATIONAL SEARCH REPORT**

Information on patent family members

International application No.

**PCT/US2013/024909**

Patent document cited in search report	Publication date	Patent family member(s)	Publication date
US 2011-0223026 A1	15.09.2011	EP 2365185 A2	14.09.2011
US 2010-0158699 A1	24.06.2010	CA 2688374 A1	22.06.2010
		US 8100666 B2	24.01.2012
US 2011-0146298 A1	23.06.2011	EP 2339118 A2	29.06.2011
US 4664599 A	12.05.1987	EP 0202188 A1	20.11.1986
		EP 0202188 B1	14.06.1989
		JP 2586890 B2	05.03.1997
		JP 61-252803 A	10.11.1986
US 4973221 A	27.11.1990	CA 2012243 C	25.01.2000
		GB 2233394 A	09.01.1991
		JP 02-286802 A	27.11.1990
		JP 2572475 B2	16.01.1997