



US 20090044717A1

(19) **United States**

(12) **Patent Application Publication**
Husseini et al.

(10) **Pub. No.: US 2009/0044717 A1**

(43) **Pub. Date: Feb. 19, 2009**

(54) **BASE FOR A CARTRIDGE CASING BODY FOR AN AMMUNITION ARTICLE, A CARTRIDGE CASING BODY AND AN AMMUNITION ARTICLE HAVING SUCH BASE, WHEREIN THE BASE IS MADE FROM PLASTIC, CERAMIC, OR A COMPOSITE MATERIAL**

(75) Inventors: **Nabil Husseini**, Washington, DC (US); **David E. Byron**, Longwood, FL (US)

Correspondence Address:
CANTOR COLBURN, LLP
20 Church Street, 22nd Floor
Hartford, CT 06103 (US)

(73) Assignee: **Development Capital Management Company**, Chantilly, VA (US)

(21) Appl. No.: **12/186,174**

(22) Filed: **Aug. 5, 2008**

Related U.S. Application Data

- (60) Division of application No. 11/160,682, filed on Jul. 5, 2005, now Pat. No. 7,441,504, which is a continuation-in-part of application No. 10/912,162, filed on Aug. 6, 2004, now abandoned, which is a division of application No. 09/832,020, filed on Apr. 11, 2001, now Pat. No. 6,845,716, which is a division of application No. 09/265,946, filed on Mar. 11, 1999, now Pat. No. 6,752,084.
- (60) Provisional application No. 60/116,232, filed on Jan. 15, 1999.

Publication Classification

- (51) **Int. Cl.**
F42B 5/30 (2006.01)
F42B 5/26 (2006.01)
- (52) **U.S. Cl.** **102/466; 102/465**
- (57) **ABSTRACT**

An apparatus for manufacturing an ammunition article, includes forming a projectile of an ammunition article at a first station of an apparatus, transporting the projectile within the apparatus to a second station of the apparatus, and injection molding at the second station a cartridge casing body of the ammunition article around at least a portion of the projectile.

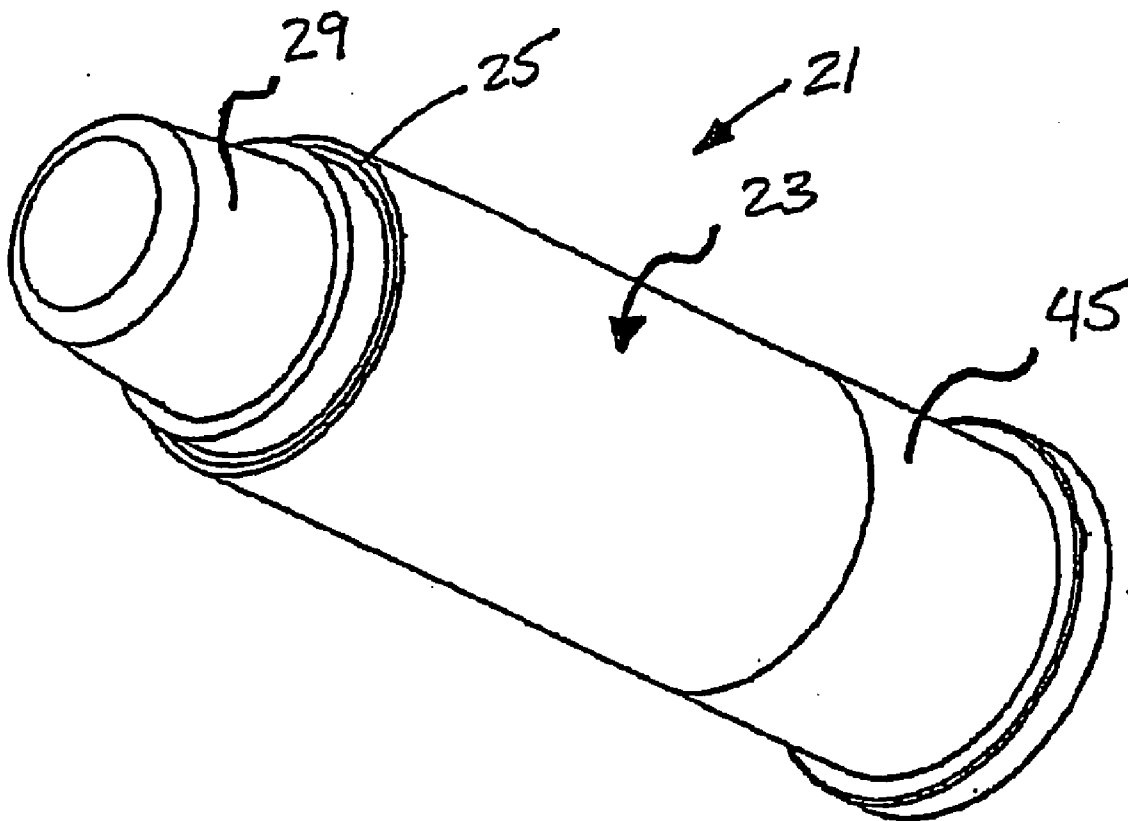

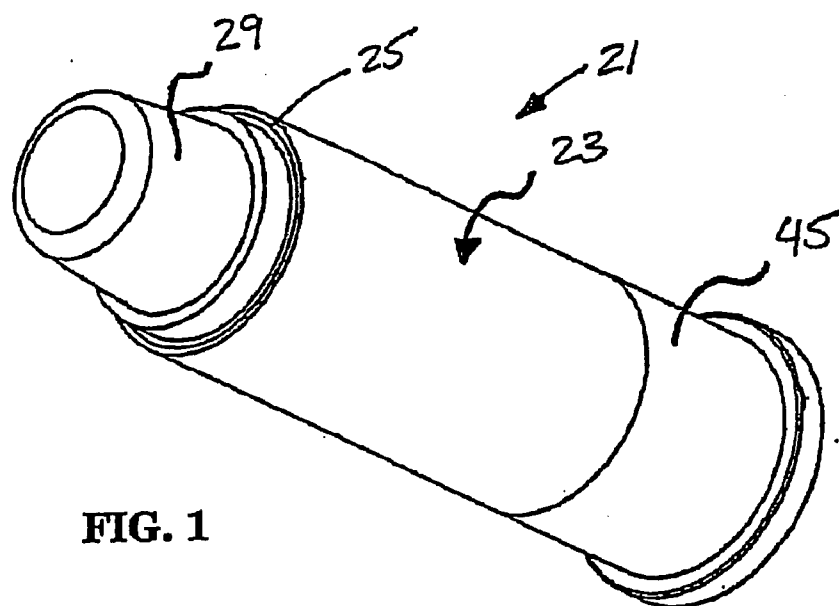

FIG. 1

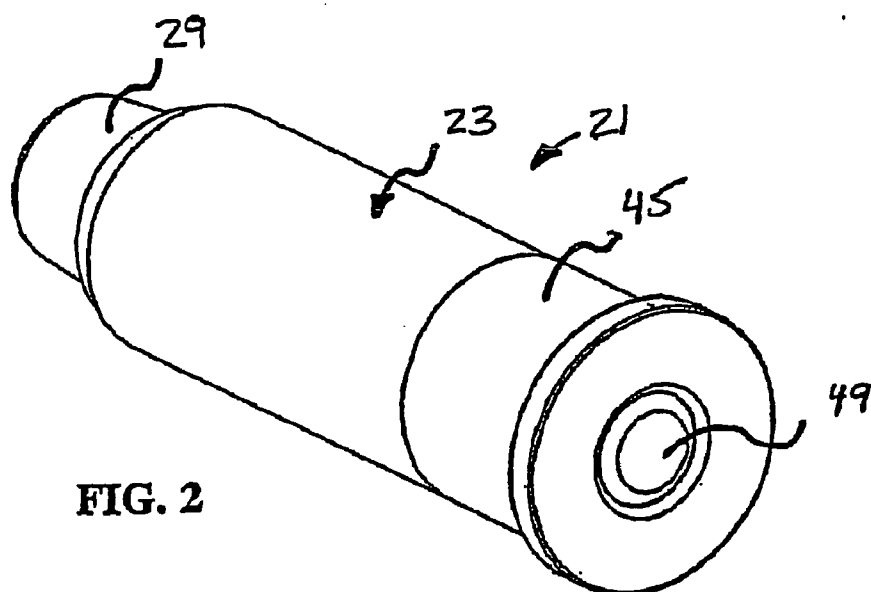

FIG. 2

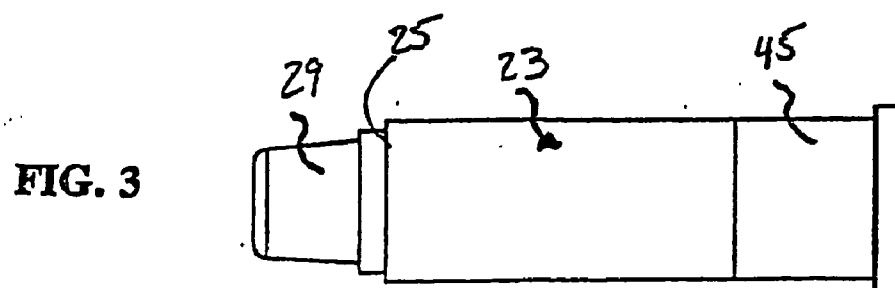

FIG. 3

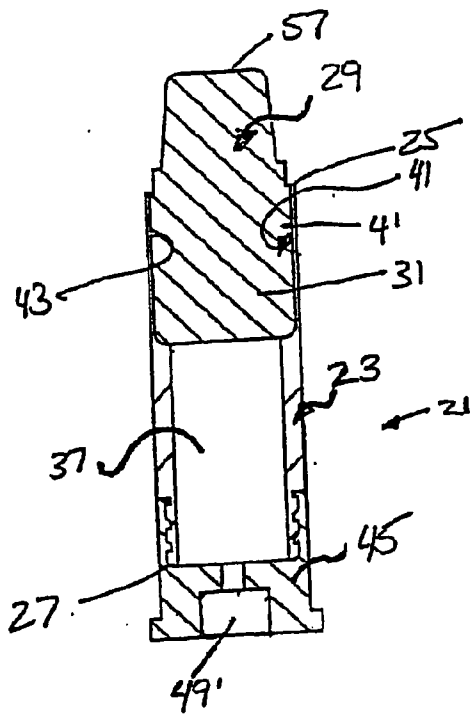

FIG. 4A

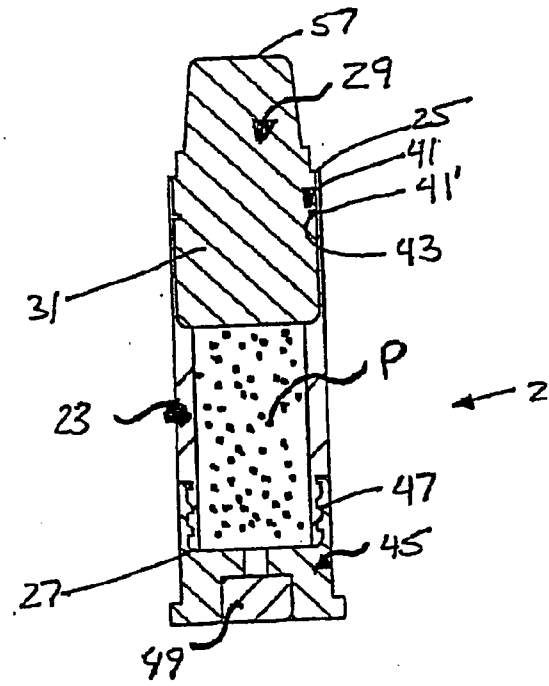

FIG. 4B

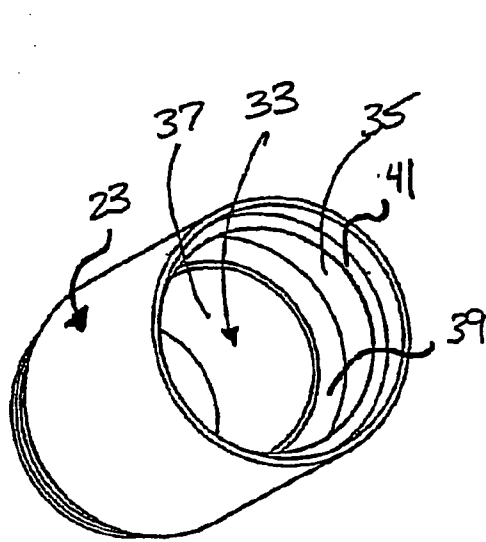

FIG. 5

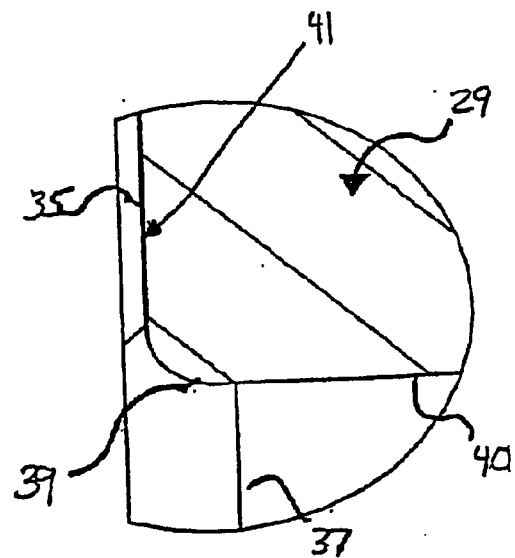

FIG. 6

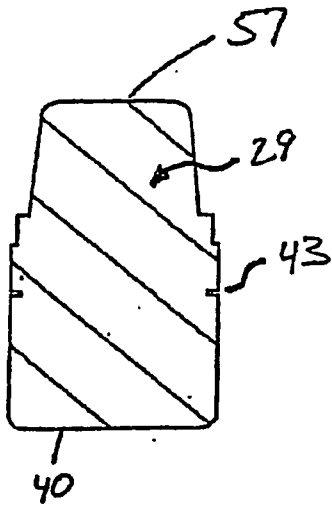

FIG. 7

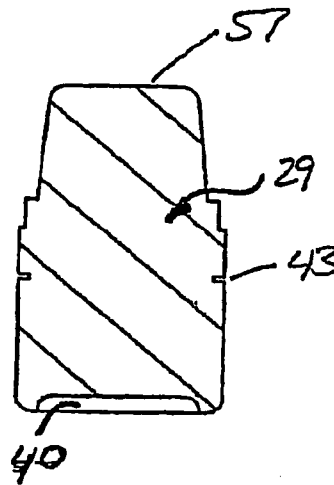

FIG. 8

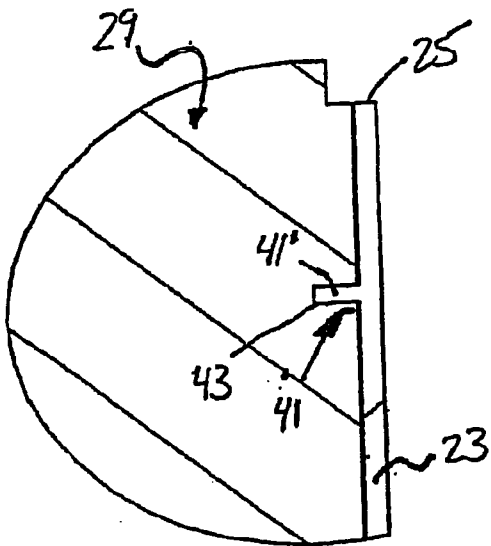

FIG. 9A

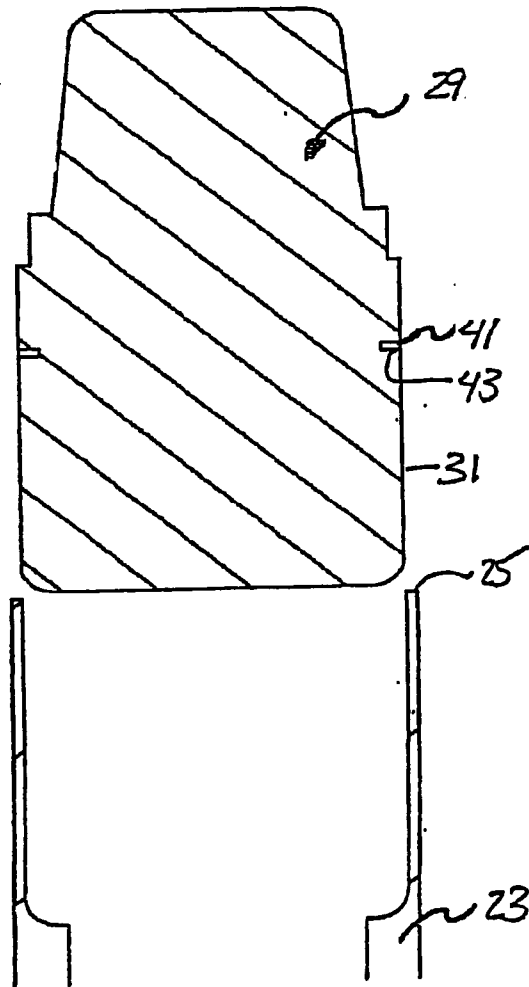

FIG. 10

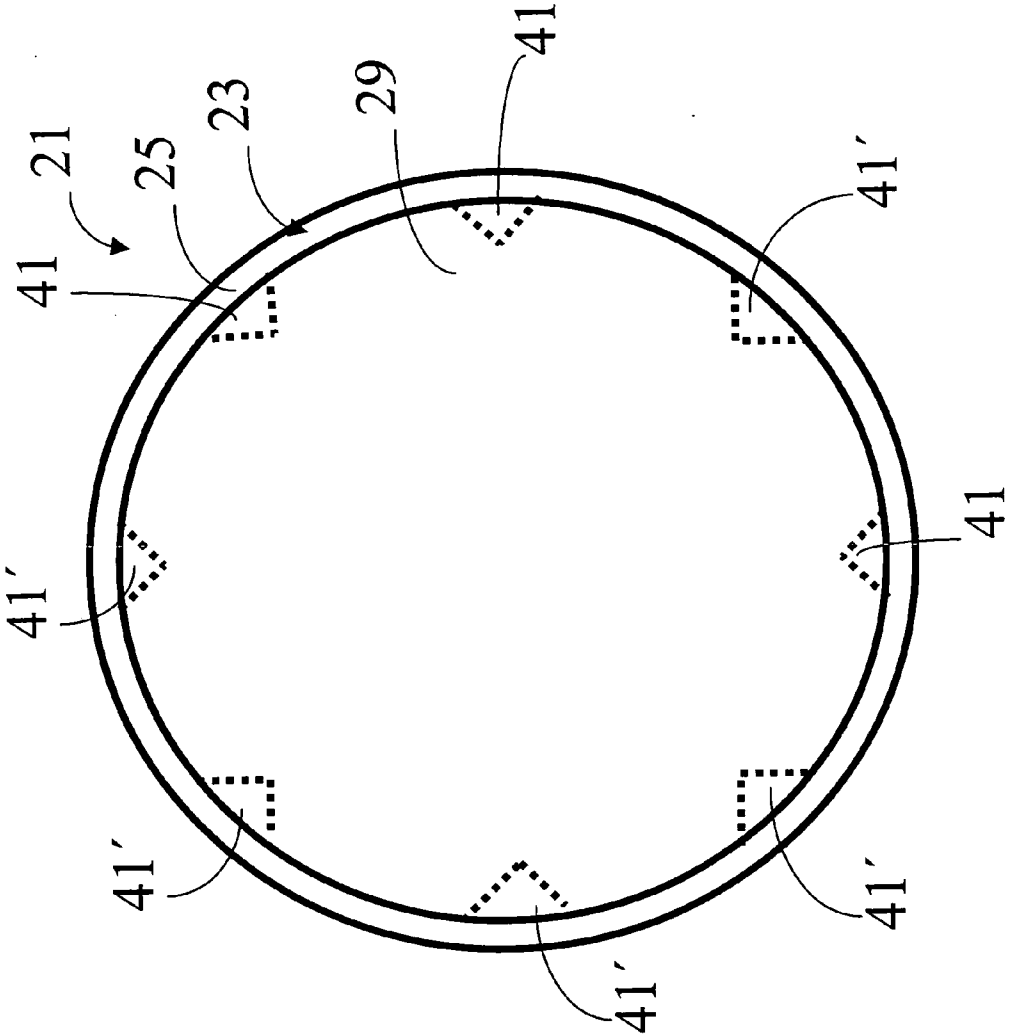

FIG. 9B

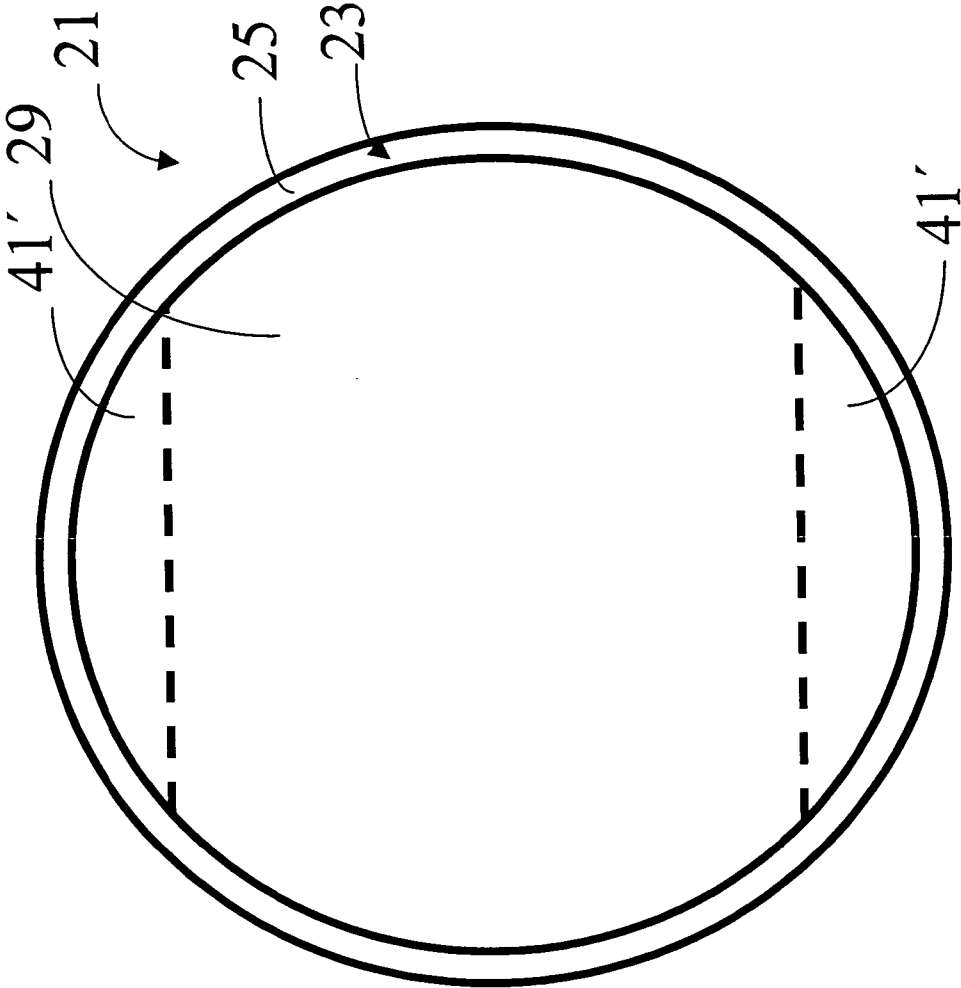

FIG. 9C

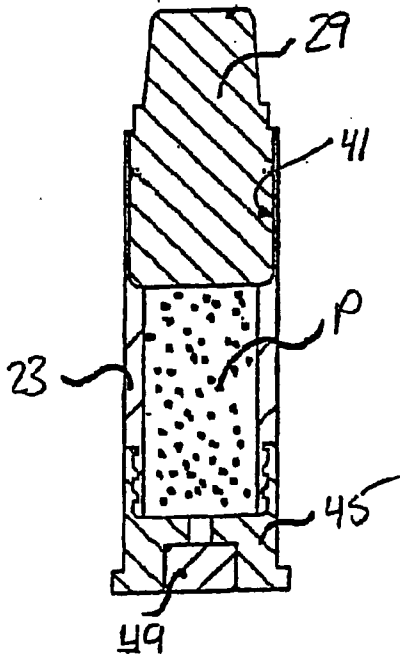

FIG. 11

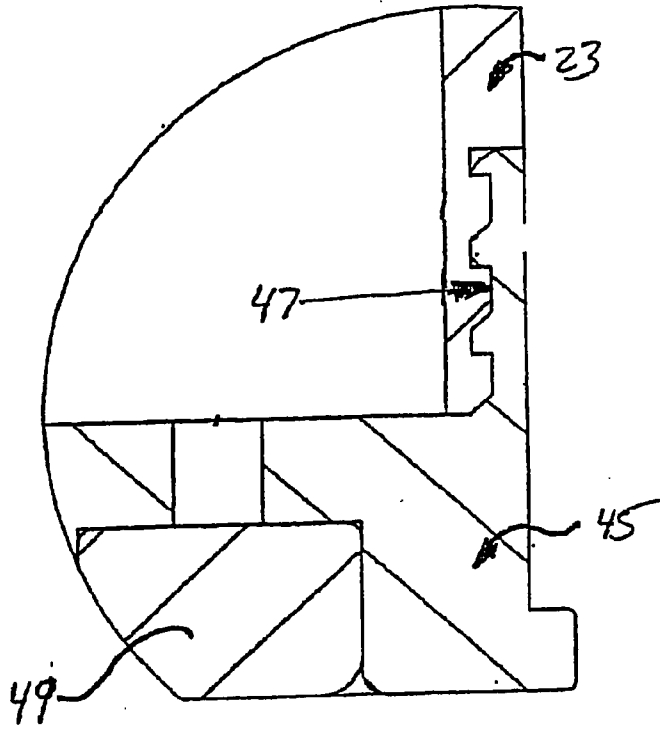

FIG. 12

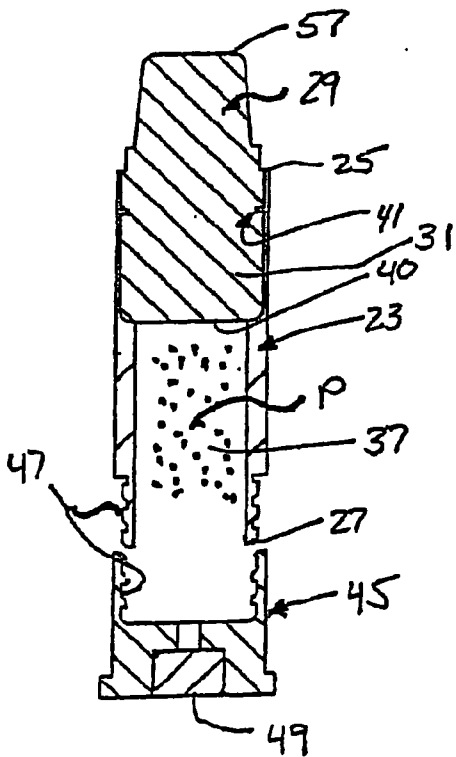

FIG. 15

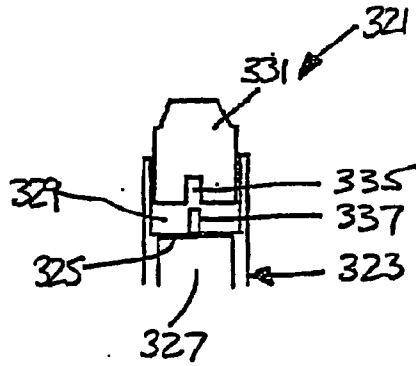

FIG. 28

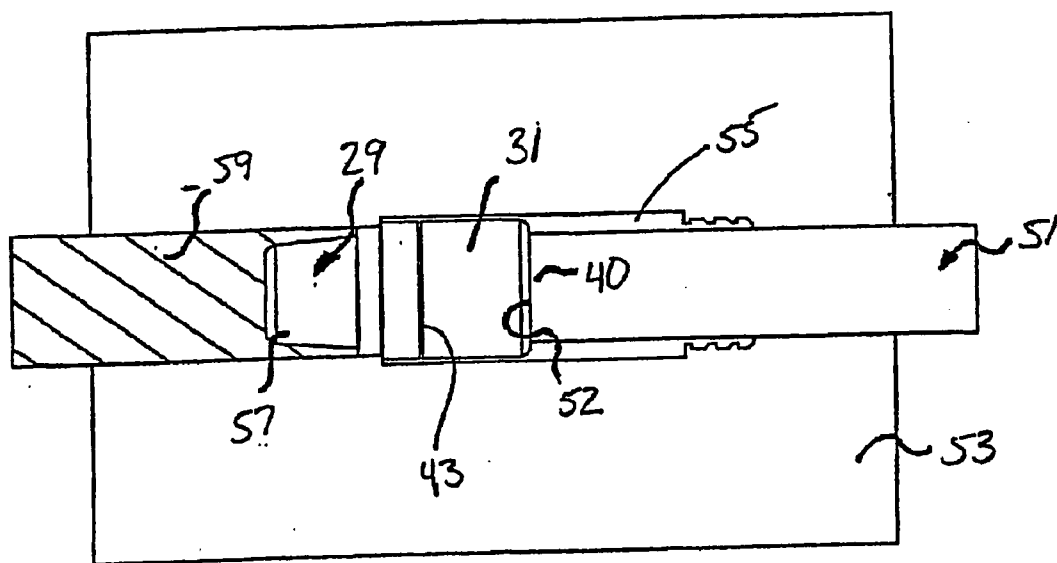

FIG. 13A

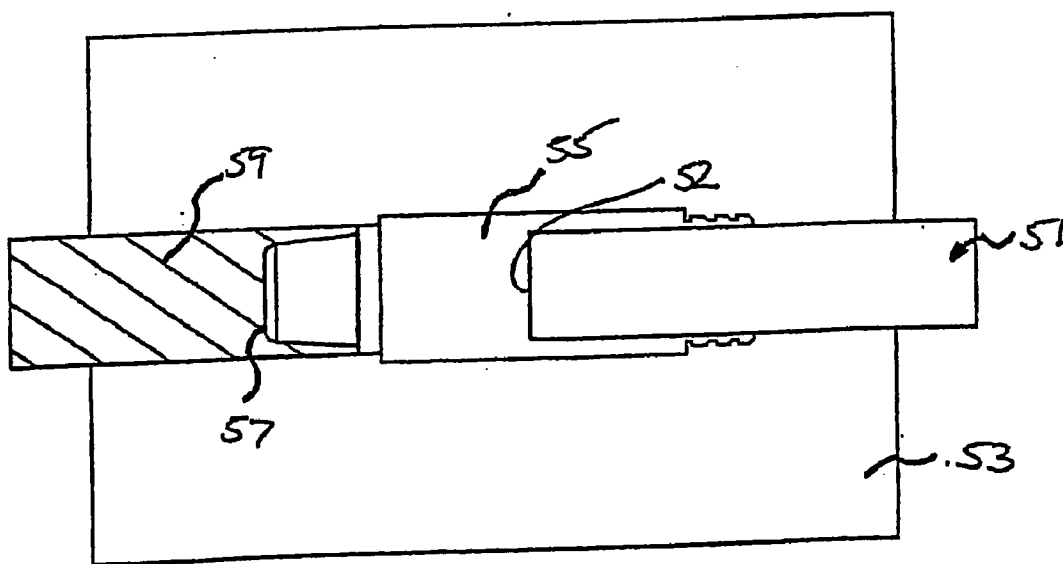

FIG. 13B

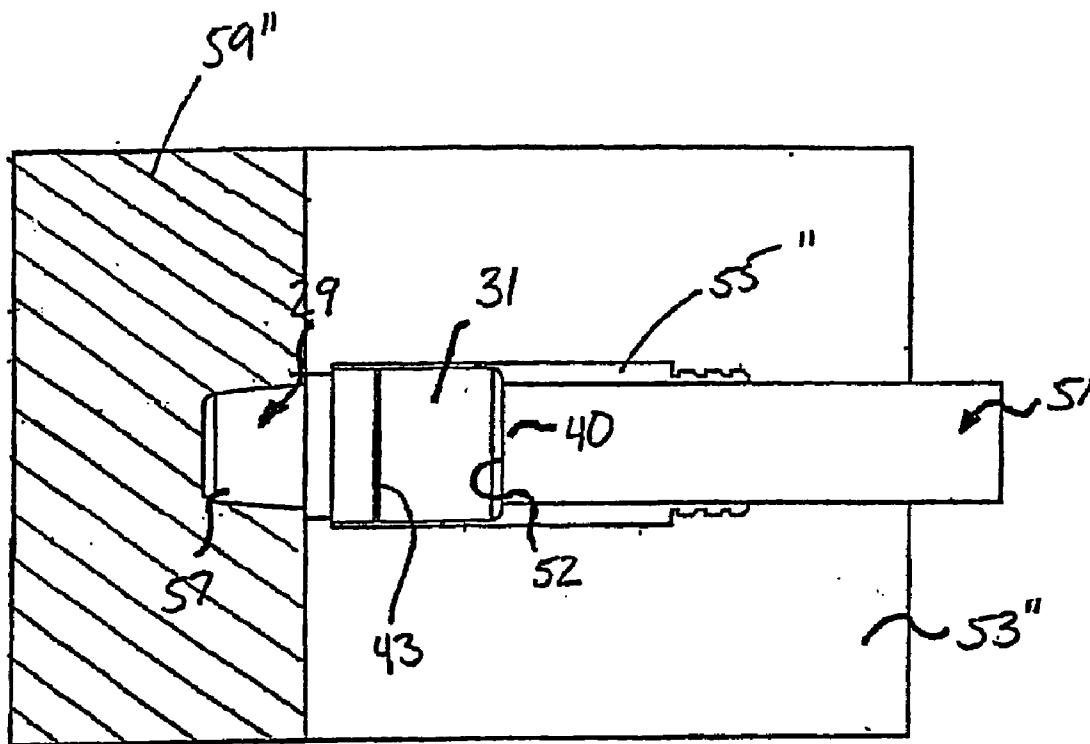

FIG. 13C

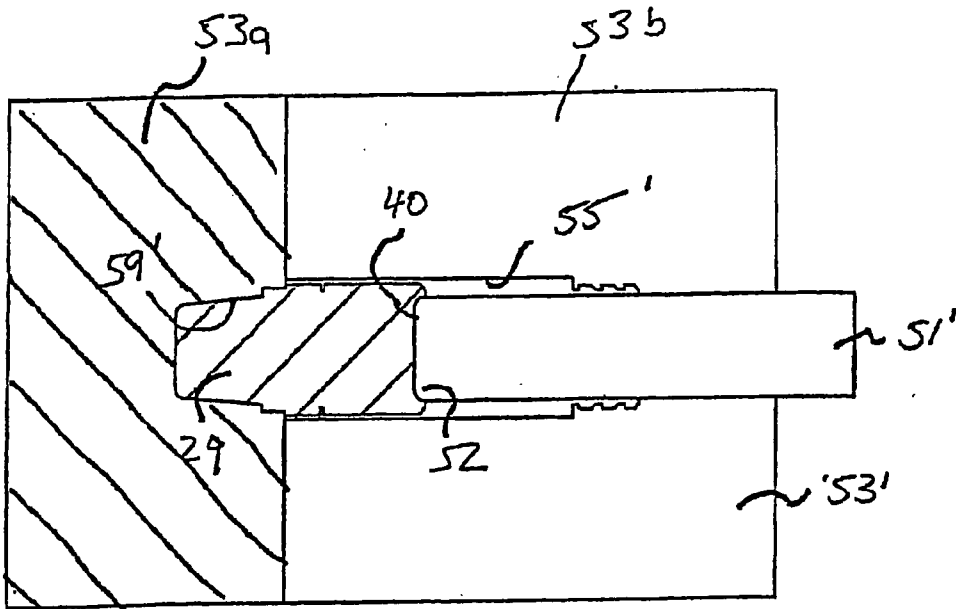

FIG. 14A

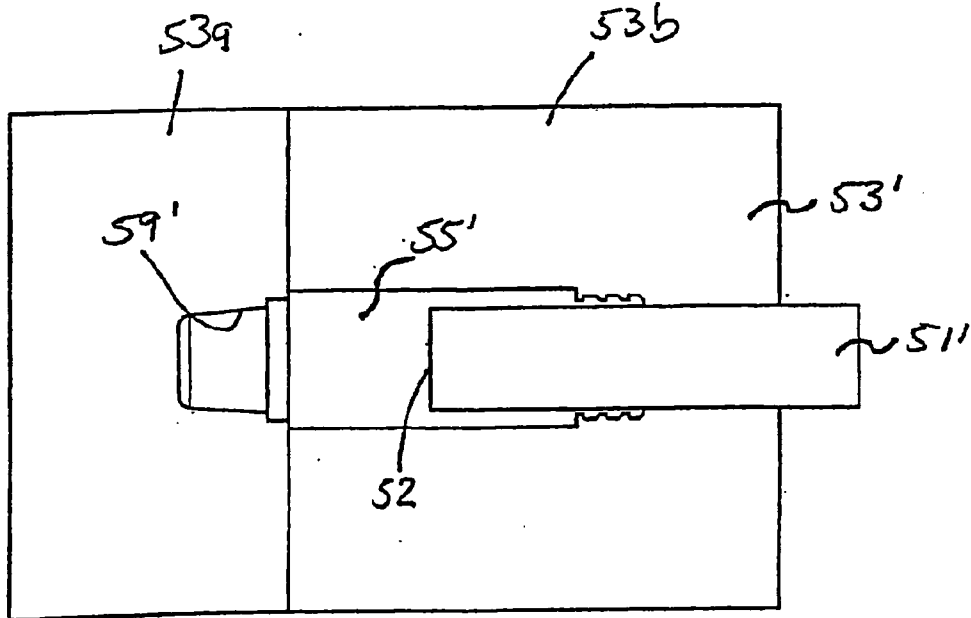

FIG. 14B

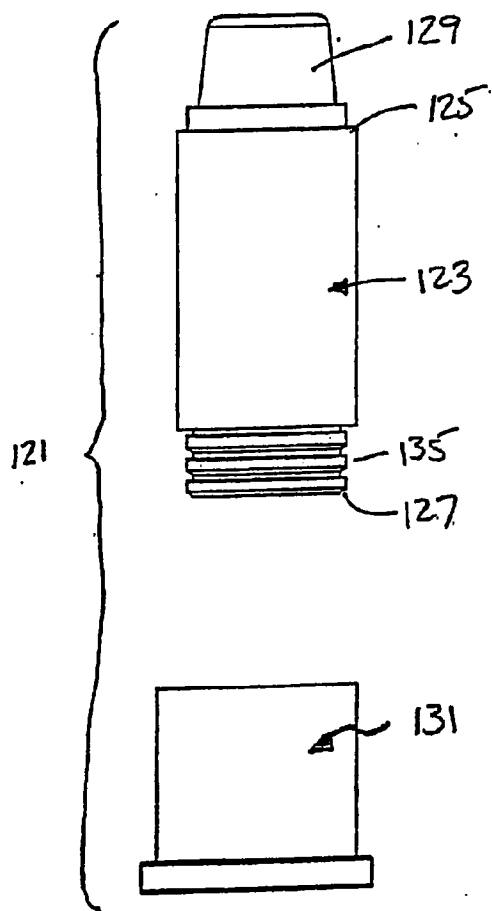

FIG. 16

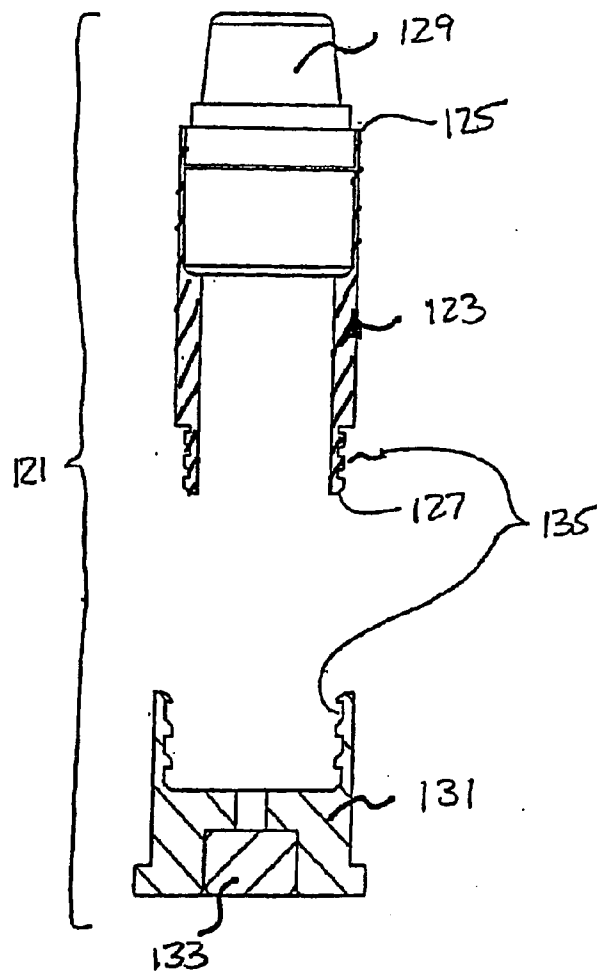

FIG. 17

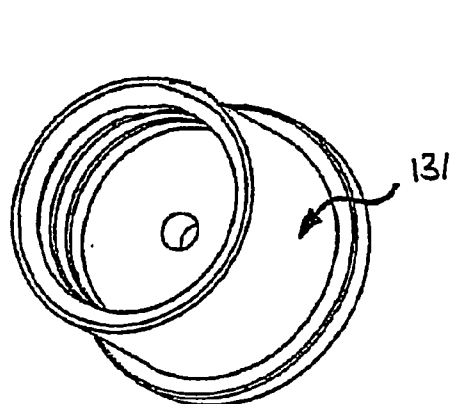

FIG. 18A

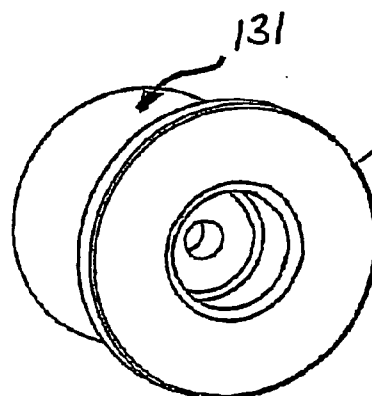

FIG. 19

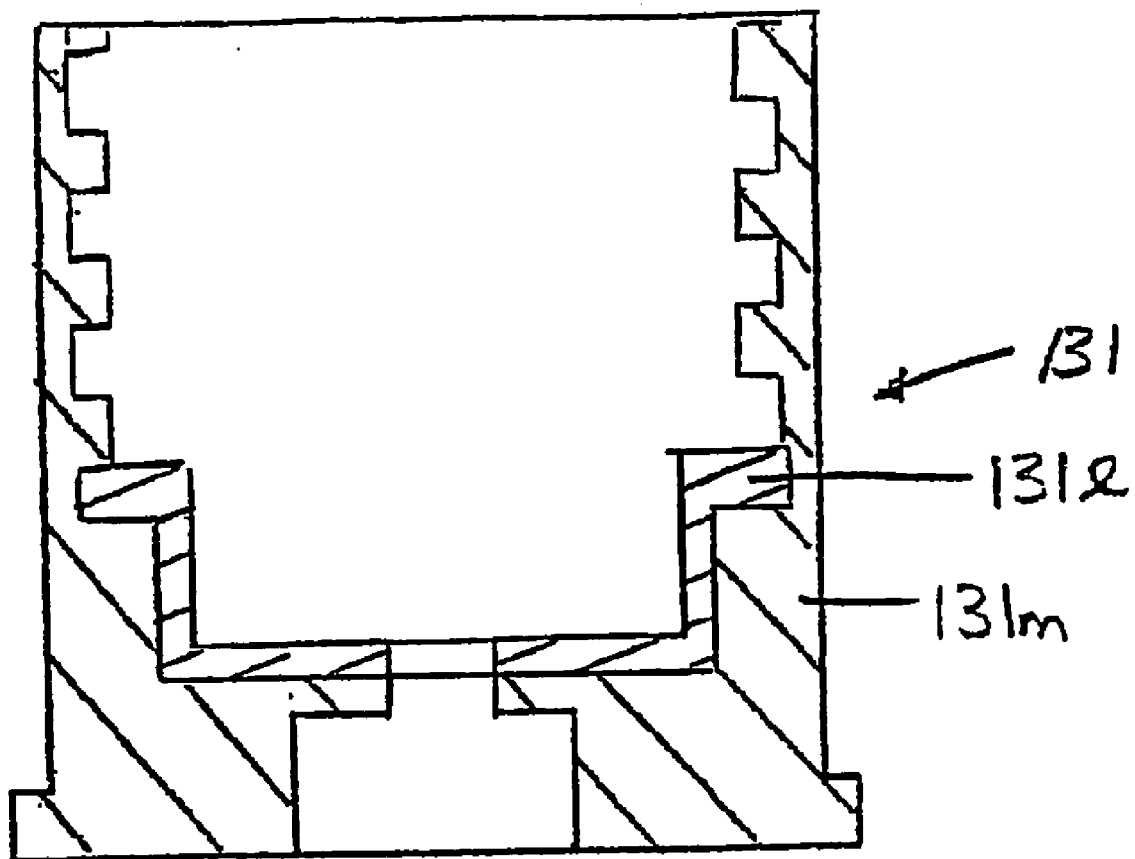

FIG. 18B

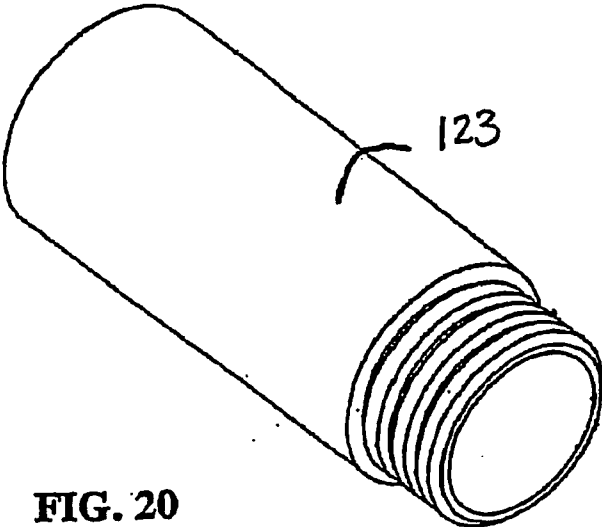

FIG. 20

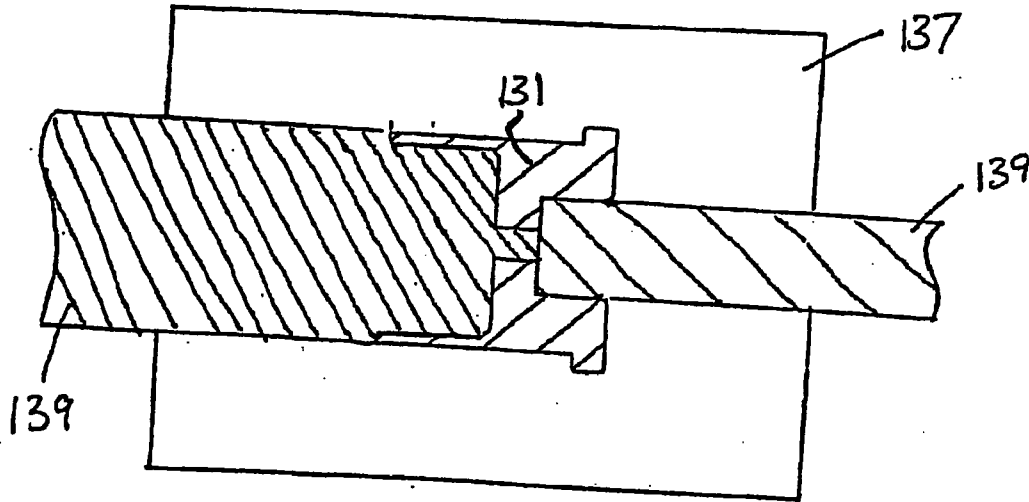

FIG. 21

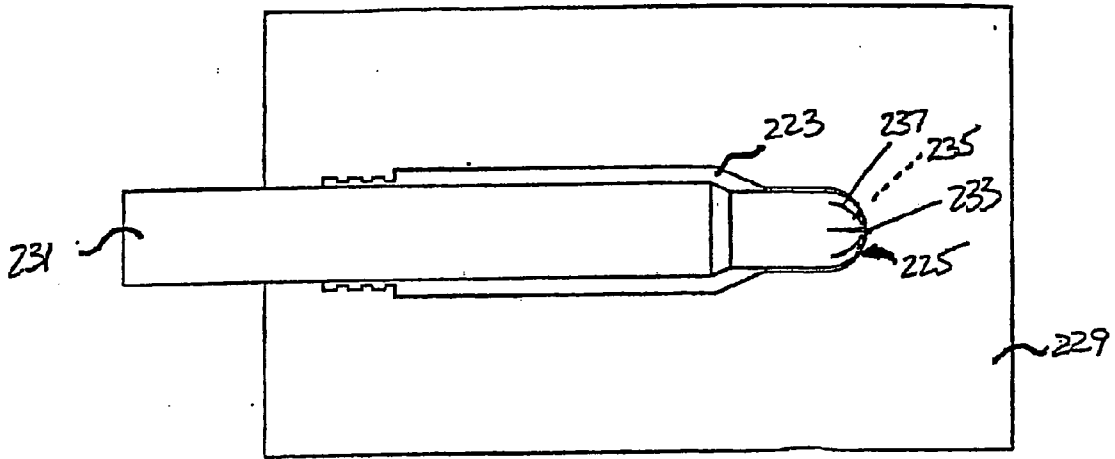

FIG. 23

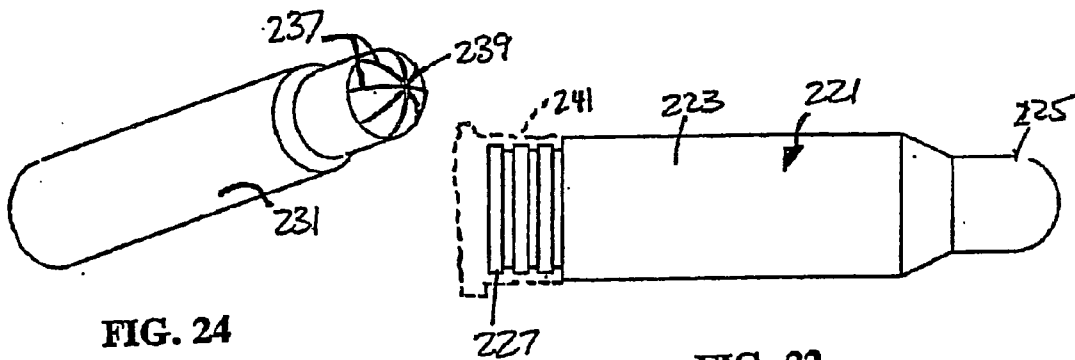

FIG. 24

FIG. 22

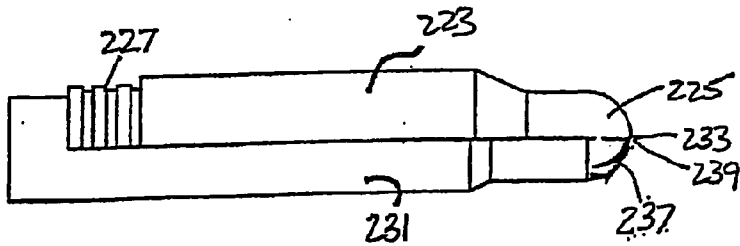

FIG. 27

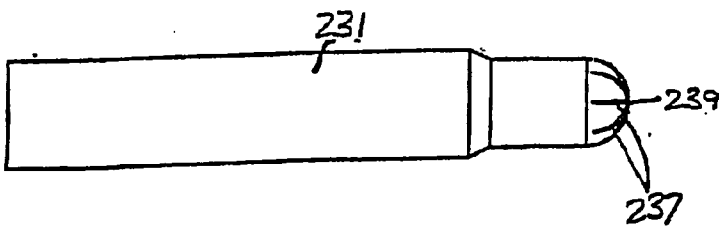

FIG. 26

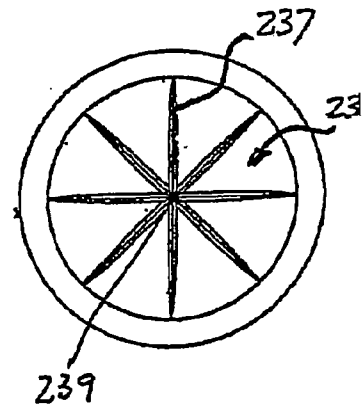

FIG. 25

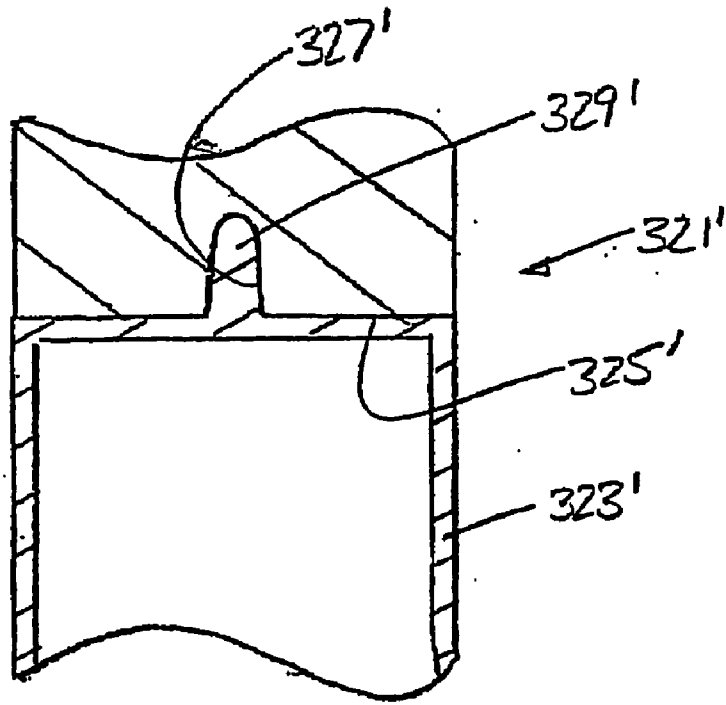

FIG. 29

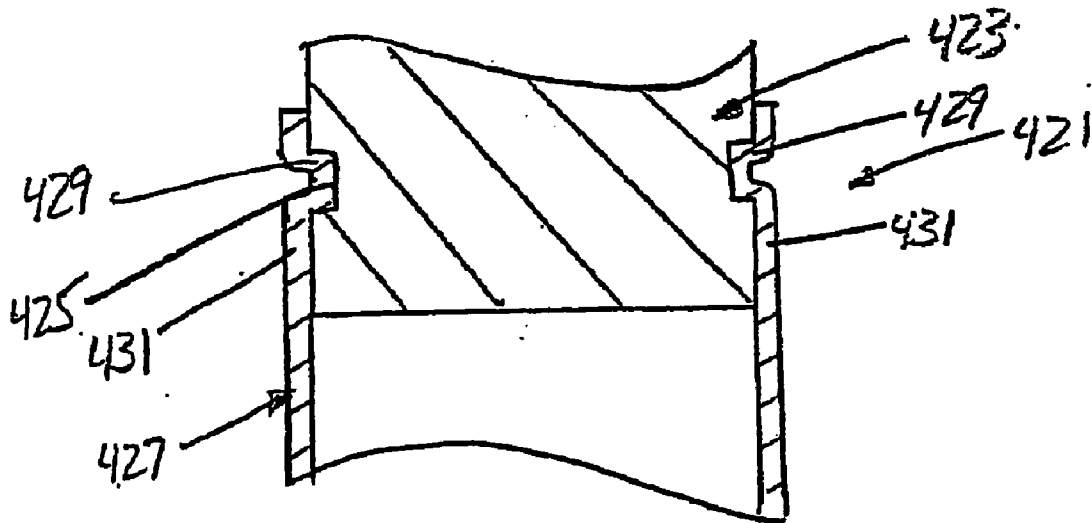

FIG. 30

**BASE FOR A CARTRIDGE CASING BODY
FOR AN AMMUNITION ARTICLE, A
CARTRIDGE CASING BODY AND AN
AMMUNITION ARTICLE HAVING SUCH
BASE, WHEREIN THE BASE IS MADE FROM
PLASTIC, CERAMIC, OR A COMPOSITE
MATERIAL**

**CROSS-REFERENCE TO RELATED
APPLICATIONS**

[0001] This application is a divisional application of U.S. patent application Ser. No. 11/160,682, which is a continuation-in-part of U.S. patent application Ser. No. 10/912,162, filed on Aug. 6, 2004, which is a divisional of U.S. patent application Ser. No. 09/832,020, filed on Apr. 11, 2001 and now U.S. Pat. No. 6,845,716, which is a divisional of U.S. patent application Ser. No. 09/265,946, filed on Mar. 11, 1999 and now U.S. Pat. No. 6,752,084, and which claims the benefit of U.S. Provisional Application No. 60/116,232, filed Jan. 15, 1999. The subject matter of U.S. patent application Ser. No. 10/912,162, U.S. patent application Ser. No. 09/832,020, U.S. patent application Ser. No. 09/265,946, and U.S. Provisional Application No. 60/116,232 is incorporated herein by reference.

FIELD OF THE INVENTION

[0002] The present invention relates to ammunition articles and methods of making ammunition articles and, more particularly, to ammunition articles with plastic components such as cartridge casing bodies and bases, and methods of making ammunition articles with plastic components.

BACKGROUND AND SUMMARY

[0003] Plastic cartridge casings have been known for many years but have failed to provide satisfactory ammunition that could be produced in commercial quantities with sufficient safety, ballistic, and handling characteristics. The problems evidenced by all of the known methods of producing plastic or substantially plastic ammunition include the possibility of the projectile being pushed into the cartridge casing, the bullet pull being too light such that the bullet can fall out, the bullet pull being insufficient to create enough chamber pressure, the bullet pull being too great causing excessive chamber pressure, the bullet pull not being uniform from round to round, portions of the cartridge casing breaking off upon firing of the projectile causing damage or danger when subsequent rounds are fired or when the casing portions themselves become projectiles, and expense due to manufacturing techniques or multiple material constructions. In the manufacture of blanks using plastic cartridge cases, similar problems to those present with prior art cartridge cases for conventional ammunition exist, as well as problems associated with portions of the cartridge cases breaking off and becoming dangerous, high velocity plastic projectiles.

[0004] Certain of the foregoing problems are addressed in European Patent Application

[0005] 0131863, which discloses a plastic cartridge casing that is provided with a ring or a plurality of rings or with a pronounced radially inward taper to engage corresponding surfaces on the bullet so that the bullet may be snapped into the casing. However, the technique of forming a cartridge casing and then snapping a bullet into the casing is time consuming in that it involves multiple steps, is manpower and

equipment intensive in that different equipment is necessary to perform various tasks in the manufacturing process, and still risks a less than perfect fit between bullet and casing in that the casings are not custom fit to each bullet. It is desirable to provide ammunition articles having plastic cartridge casing bodies, cartridge casings with plastic cartridge casing bodies, and plastic cartridge casing bodies that ensure a high-quality fit between the plastic cartridge casing body and the projectile, and methods of manufacture for such articles that are simple and require minimal manpower and equipment.

[0006] According to one aspect of the present invention, an ammunition article is provided, the ammunition article including a molded plastic cartridge casing body having a first end and a second end, and a projectile attached to the first end of the cartridge casing body. The cartridge casing body is molded around at least a portion of the projectile.

[0007] According to another aspect of the present invention, an ammunition article is provided, the ammunition article including a cartridge casing body having a first end and a second end, a projectile attached to the first end of the cartridge casing body, and a single piece, molded plastic base, the base being attached to the second end of the cartridge casing body.

[0008] According to another aspect of the present invention, an ammunition article is provided, the ammunition article including a molded plastic cartridge case body having a closed front end and a second end.

[0009] According to another aspect of the present invention, an ammunition article is provided, the ammunition article including a molded plastic cartridge case body, the cartridge case body including a web dividing an internal volume of the body to define a lower cavity for receiving a propellant and an upper cavity for receiving a projectile, the web including an upwardly extending prong for being received in a corresponding recess in a base of the projectile to fasten the body to the projectile.

[0010] According to another aspect of the present invention, a method of making an ammunition article includes the steps of molding plastic around at least a portion of a projectile to form a plastic cartridge casing body having a first end to which the projectile is attached and a second end.

[0011] According to another aspect of the present invention, a method of making an ammunition article includes the steps of molding plastic to form a single piece, molded plastic base, and attaching the base to an end of a cartridge casing body.

[0012] According to another aspect of the present invention, a method of making an ammunition article includes the steps of molding plastic around a core pull to form a molded plastic cartridge case body having a closed front end and a second end, and removing the core pull from the cartridge casing body.

[0013] According to another aspect of the present invention, a method of making an ammunition article includes the steps of molding plastic to form a molded plastic cartridge case body, the cartridge case body including a web dividing an internal volume of the body to define a lower cavity for receiving a propellant and an upper cavity for receiving a projectile, the web including an upwardly extending prong, and causing the upwardly extending prong to be received in a corresponding recess in a base of the projectile to fasten the body to the projectile.

BRIEF DESCRIPTION OF THE DRAWINGS

[0014] The features and advantages of the present invention are well understood by reading the following detailed

description in conjunction with the drawings in which like numerals indicate similar elements and in which:

[0015] FIG. 1 is a top perspective view of an ammunition article according to a first embodiment of the present invention;

[0016] FIG. 2 is a bottom perspective view of an ammunition article according to the first embodiment of the present invention;

[0017] FIG. 3 is a side view of an ammunition article according to the first embodiment of the present invention;

[0018] FIGS. 4A and 4B are side, cross-sectional views of an ammunition article according to the first embodiment of the present invention;

[0019] FIG. 5 is a top perspective view of a cartridge casing body according to the first embodiment of the present invention and illustrated without the projectile;

[0020] FIG. 6 is a cross-sectional view of a portion of an ammunition article according to the first embodiment of the present invention;

[0021] FIG. 7 is a cross-sectional view of an embodiment of a projectile for use in connection with the ammunition article according to the first embodiment of the present invention;

[0022] FIG. 8 is a cross-sectional view of another embodiment of a projectile for use in connection with the ammunition article according to the first embodiment of the present invention;

[0023] FIG. 9A is a cross-sectional view of a portion of an ammunition article according to the first embodiment of the present invention;

[0024] FIGS. 9B and 9C are partial, top views of a portion of an ammunition article according to the first embodiment of the present invention, showing possible forms of flanges;

[0025] FIG. 10 is a cross-sectional view of a portion of an embodiment of the ammunition article according to the first embodiment of the present invention shown after firing;

[0026] FIG. 11 is a cross-sectional view of an embodiment of the ammunition article according to the first embodiment of the present invention;

[0027] FIG. 12 is a cross-sectional view of a portion of an ammunition article according to the first embodiment of the present invention;

[0028] FIG. 13A-14B are partially cross-sectional views of molding equipment for making an embodiment of a cartridge casing body for an ammunition article according to the first embodiment of the present invention;

[0029] FIG. 15 is a cross-sectional view of an assembly step according to a method for making an ammunition article according to the first embodiment of the present invention;

[0030] FIG. 16 is an exploded view of an ammunition article according to a second embodiment of the present invention;

[0031] FIG. 17 is an exploded, cross-sectional view of an ammunition article according to the second embodiment of the present invention;

[0032] FIG. 18A is a front perspective view of a molded plastic base according to an embodiment of the ammunition article according to the second embodiment of the present invention;

[0033] FIG. 18B is a side, cross-sectional view of a molded base according to an embodiment of the ammunition article;

[0034] FIG. 19 is a rear perspective view of a molded plastic base according to an embodiment of the ammunition article according to the second embodiment of the present invention;

[0035] FIG. 20 is a rear perspective view of an embodiment of a cartridge casing body for use with an embodiment of the ammunition article according to the second embodiment of the present invention;

[0036] FIG. 21 is a partially cross-sectional view of molding equipment for making a plastic base for an ammunition article according to the second embodiment of the present invention;

[0037] FIG. 22 is a side view of an ammunition article according to a third embodiment of the present invention;

[0038] FIG. 23 is a partially cross-sectional view of molding equipment for making an ammunition article according to the third embodiment of the present invention;

[0039] FIG. 24 is a front perspective view of a core pull for use in making an ammunition article according to the third embodiment of the present invention;

[0040] FIG. 25 is a front end view of a core pull for use in making an ammunition article according to the third embodiment of the present invention;

[0041] FIG. 26 is a side view of a core pull for use in making an ammunition article according to the third embodiment of the present invention;

[0042] FIG. 27 is a side view of a core pull inserted in a partially broken ammunition article according to the third embodiment of the present invention;

[0043] FIG. 28 is a side, cross-sectional view of a portion of an ammunition article according to a fourth embodiment of the present invention;

[0044] FIG. 29 is a side, cross-sectional view of a portion of an ammunition article according to a fifth embodiment of the present invention; and

[0045] FIG. 30 is a side, cross-sectional view of a portion of an ammunition article according to a sixth embodiment of the present invention.

DETAILED DESCRIPTION

[0046] An ammunition article 21 according to an embodiment of the present invention is shown in FIGS. 1-3. As seen in cross-section in FIGS. 4A and 4B, the ammunition article 21 includes a molded plastic cartridge casing body 23 having a first end 25 and a second end 27. A projectile 29 is attached to the first end 25 of the cartridge casing body 23. The cartridge casing body 23 is a molded plastic part, and is formed by plastic being molded around at least a portion 31 of the projectile 29. As discussed with reference to FIG. 29, if desired or necessary, the cartridge casing body may be formed by plastic being molded to conform only with a bottom of a projectile, with a plastic protrusion extending into a cavity in the bottom of the projectile. The projectile 29 is preferably any one of the wide variety of well-known projectiles but may, if desired or necessary, include one or more features useful in connection with the present invention.

[0047] As seen in FIG. 5 (showing the cartridge casing body with the projectile removed for illustration) the cartridge casing body 23 preferably includes an interior volume 33 including a first interior portion 35 defined by the portion 31 of the projectile 29 and a second interior portion 37 having a smaller diameter than the first interior portion and being separated from the first interior portion by a shoulder 39. As seen in FIGS. 5 and 6, the shoulder 39 is preferably of sufficient size to prevent axial movement of the projectile 29 into the second interior portion 37. The second interior volume 37 is preferably formed by a core pull (FIGS. 13A-14B) used in a cartridge casing body molding operation wherein a leading

end of the core pull preferably abuts against the base 40 of the projectile 29. As seen in FIG. 7, the base 40 of the projectile may be flat or, as seen in FIG. 8, contoured, such as by being concave. The base 40 may be contoured to any shape desired or necessary, such as concave, convex, a combination of concave or convex, have straight portions, or curved portions, depending upon factors such as the ballistic requirements of the projectile.

[0048] The projectile 29 is preferably attached to the cartridge casing body 23 by one or more attachment arrangements 41 directed to preventing axial movement of the projectile relative to the cartridge casing body prior to firing, such as during storage or shipment, and during accidents such as dropping of the ammunition article. Depending upon the type of ammunition article being manufactured, desirable characteristics of the attachment arrangement 41 may include the ability to provide sufficient bullet pull to permit creation of neither too much nor too little chamber pressure during firing of the projectile, ensuring uniform bullet pull from round to round, and avoiding causing portions of the cartridge casing body to break off when the ammunition article is fired. Suitable attachment arrangements 41 include a heat bond, an adhesive bond, and a weld, such as an ultrasonic weld, between the portion 31 of the projectile and the cartridge casing body 23. The attachment arrangement may be a mechanical attachment arrangement wherein portions of the cartridge casing body 23 and the portion 31 of the projectile 29 are caused to interconnect. The attachment arrangement may, of course, be nothing more than a metal to plastic bond between the portion 31 of the projectile 29 and the cartridge casing body 23 created during the molding operation.

[0049] A form of attachment arrangement 41, seen in detail in FIG. 9A, includes a flange 41' on the cartridge casing body 23 extending into a recess 43 in the projectile 29. Optimal dimensions for the flange 41' will vary depending upon the specific type of ammunition article 21 to be made. When the cartridge casing body 23 is made of a modified ZYTEL resin, available from E.I. DuPont De Nemours Co., a modified 612 nylon resin, modified to increase elastic response, and the ammunition article is so-called A38 Special type ammunition, a desirable dimension for an annular flange 41' is 0.009" thick by 0.020" wide, i.e., the recess 43 is an annular recess in the projectile 29 that is about $\frac{1}{1000}$ " thick by 0.020" wide. The flange 41' and the recess 43 are not limited to being annular, and can be any of a variety of shapes and sizes, such as pins and grooves, detents and detent receiving recesses, helices, such as screw threads, or any other suitable mechanically interconnectable structure sufficient to retain the projectile 29 in position in the cartridge casing body 23. By proper selection of materials and flange 41' and recess 43 size, it is possible to design to a very exact degree features of the ammunition article 21 such as bullet pull. As seen in FIGS. 9B and 9C, the flange 41' need not be continuous around the entire circumference of the projectile, such as in the embodiment shown in FIG. 5, but may be in the form of multiple, discontinuous or interrupted forms. The shape of the flange 41' may be any suitable shape, such as a cone, a pyramid, a half-sphere, a half circular cylinder, a cube, or other geometrical form.

[0050] As seen in FIG. 10, the flange 41', when provided, is preferably sized such that, and the cartridge casing body 23 is preferably made of a plastic material suitable for its specific intended application such that, upon firing of the projectile 29, the flange 41' breaks off from the rest of the body 23 and

is carried off with the projectile, without also causing other portions of the body 23 to break off. If desired or necessary, multiple flanges 41 and recesses 43 can be arranged along a length of the cartridge casing body 23 and the portion 31 of the projectile 29. It will be understood that an ammunition article 21 with a flange 41' is just one embodiment of the present invention, and that the flange may be omitted in favor of one or more alternative attachment arrangements, such as metal-plastic bonding from the molding operation, interference fit, heat bonding, adhesive, or ultrasonic welding, as seen in FIG. 11.

[0051] The ammunition article 21 preferably also includes a base 45 attached to the second end 27 of the cartridge casing body 23. One suitable material for the cartridge casing body 23 is a modified ZYTEL resin, available from E.I. DuPont De Nemours Co., a modified 612 nylon resin, modified to increase elastic response. In embodiments of the present invention wherein a molded cartridge casing body may be provided, a suitable cartridge casing body may also be made of a moldable material that forms part of the propellant pack, i.e., a moldable propellant, or otherwise is itself combustible or consumable by a propellant such as a powder ignition. The base 45 may be made of any suitable conventional material, for example, a metal material such as brass. According to one embodiment of the present invention, the base 45 is made of a plastic material, and is preferably molded out of a long fiber reinforced nylon material to provide great stiffness, high compressive strength, and minimal cold flow, although other well known materials may be used for the base. As desired or necessary, the base may be a metal base, such as a brass base, or a plastic material base, a ceramic base, a composite base, a combination of plastic, composite, or ceramic, or may incorporate the composite reinforced ceramic technology disclosed in U.S. patent application Ser. No. 08/590,621, which is expressly incorporated by reference. If desired or necessary, the base 45 and the cartridge casing body 23 can be made of the same material. For at least some applications, the cartridge casing body 23 is preferably somewhat more flexible than the base 45 to facilitate creation of a gas seal with the chamber, but fracture properties are preferably such as to facilitate breaking off of a flange 41' (if provided) relatively cleanly from the rest of the cartridge casing body without causing other parts of the cartridge casing body to break off and follow the projectile 29 during firing. Preferably, the base 45 is sufficiently sturdy to be reusable, even when it may be necessary to replace the cartridge casing body 23 after each use.

[0052] The base 45 is attached to the cartridge casing body 23 by any suitable attachment arrangement, or combination of attachment arrangements. As seen in FIG. 12, the base 45 may be attached to the cartridge casing body 23 by a suitable attachment arrangement 47, such as by a mechanically interconnecting structure or otherwise. Suitable attachment arrangements 47 may include, for example, screw threads, a tongue and groove arrangement, flanges or pins and grooves, detent and detent receiving recesses, an interference fit, a heat bond, an adhesive, or an ultrasonic weld, or a combination of these attachment arrangements.

[0053] As seen in FIG. 4B, the ammunition article 21 preferably includes a propellant charge P inside the cartridge casing body 23. A variety of propellant charge types are well known and, for purposes of the present application and except where otherwise indicated, can be considered to broadly include all suitable types of charges, such as those that are

conventionally thought of as propellant charges and those that are conventionally considered to be explosive charges, such as black powder charges or charges such as PYRODEX, a smokeless black powder substitute available from Hodgdon Powder Co., Inc., Shawnee Mission, Kans. Depending upon the type of ammunition article 21, the ammunition article may include some means for igniting the propellant, such as a primer 49 (FIG. 4B) for igniting the propellant, or an electronic ignition 49' for igniting the propellant (shown schematically in FIG. 4A), or means for igniting the propellant may be partially or completely external to the ammunition article.

[0054] As seen in FIG. 13A, the cartridge casing body 23 is preferably made by molding plastic around at least the portion 31 of the projectile 29 to form the plastic cartridge casing body having the first end 25 to which the projectile is attached and a second end 27. Numerous plastic molding techniques are well known and are suitable for use in connection with the present application. The plastic is preferably molded around a core pull 51 such that the core pull and the portion 31 of the projectile 29 define the interior volume 33 of the plastic cartridge casing body 23. A leading end 52 of the core pull 51 preferably abuts against the base 40 of the projectile 29. After molding, the core pull 51 is removed from the plastic cartridge casing body 23. Preferably, the core pull 51 has a smaller diameter than the portion 31 of the projectile such that the interior volume 33 of the cartridge casing body 23 includes the first interior portion 35 defined by the portion of the projectile and a second interior portion 37 having a smaller diameter than the first interior portion and being separated from the first interior portion by the shoulder 39. The shoulder 39 is preferably of sufficient size to prevent axial movement of the projectile 29 into the second interior portion 37.

[0055] If desired or necessary, one or more attachment arrangements above and beyond the metal-plastic bond developed upon molding the plastic of the plastic cartridge casing body 23 around the portion 31 of the projectile 29 may be provided. The attachment arrangement 41 can be provided by, for example, heat bonding the projectile to the cartridge casing body, by adhesive bonding of the projectile to the cartridge casing body, or ultrasonic welding of the cartridge casing body to the projectile. The attachment arrangement may be provided by providing one or more recesses 43 in the portion 31 of the projectile 29 such that, when the plastic is molded around the portion of the projectile, the plastic enters the recesses and forms what is referred to herein as a flange 41' on the cartridge casing body 23, the flange 41' extending into the recess.

[0056] As seen in FIGS. 13A and 13B, the molding operation is preferably performed in a mold 53 (showing a half mold and not showing another half of the mold which is preferably symmetrical to the illustrated half mold). The mold 53 preferably includes a cavity 55 in which the core pull 51 is axially movable to a position in which the leading end of the core pull preferably abuts against the base 40 of the projectile 29. As seen in FIG. 13A, a front end 57 of the projectile 29 is preferably positioned against a mold element 59 corresponding in shape to the front end of the projectile, and which ensures proper axial positioning of the projectile relative to walls of the cavity 55. The mold element 59 may be integral with the mold 53, or may be a separate part that may be movable, as desired or necessary. An alternative form of mold 53" is shown in FIG. 13C, wherein a stationary or

movable element 59" is substituted for the mold element 59, and receives a front end of the projectile for axial positioning of the projectile 29, and separable mold halves close around a rear portion of the projectile to define, with the projectile and a pull 51, walls of a cavity 55" in which a plastic cartridge casing body is to be formed.

[0057] Another form of mold 53' is shown in FIGS. 14A and 14B and, instead of two identical or similar mold halves, such as are used in the embodiment of the method shown in FIGS. 13A and 13B, as seen in FIG. 14A, the mold 53' preferably includes an end 53a having a portion 59' in which the front end 57 of the projectile 29 is received and which positions the projectile relative to walls 55' of another end 53b of the mold in which a core pull 51' is provided. The core pull 51' is preferably axially movable relative to the end 53b. If desired or necessary, the mold end 53b may include two separable halves to facilitate removal of the cartridge casing body 23 and the projectile 29 after forming.

[0058] Regardless of the mold type used, and as discussed with reference to FIG. 13A, plastic is provided to the cavity 55 to fill voids between the walls of the cavity 55 and the walls of the portion 31 of the projectile, including any exposed portions of the base 40 of the projectile, and the core pull 51 to form the cartridge casing body 23. If one or more recesses 43 are provided in the projectile 29, corresponding flanges 41' are formed when the plastic fills the recesses. Attachment arrangements 41 such as heat bonds, adhesive bonds, and ultrasonic welds may be provided while the projectile 29 and the cartridge casing body 23 reside in the cavity 55, or after removal of the cartridge casing body and the projectile from the cavity, as desired or necessary. Techniques for providing attachment arrangements 41 are well known and will not be further described here. When the cartridge casing body 23 is molded, the core pull 51 is axially drawn from the second interior portion 37 of the cartridge casing body.

[0059] As seen in FIG. 15, the propellant charge P, such as gunpowder or other propellant, is preferably provided inside of the cartridge casing body 23, generally in the second interior portion 37 of the cartridge casing body, and the base 45 is preferably attached to the second end 27 of the cartridge casing body, preferably following removal of the cartridge casing body and the projectile 29 from the mold 53. If provided, an ignition device such as a primer (FIG. 4B) or an electronic ignition (FIG. 4A) is also provided, or, depending upon the nature of the ignition device, partially provided. If desired or necessary, it is, of course, possible to construct a mold and core arrangement to permit providing the charge P and attachment of the base 45 and primer while the cartridge casing body 23 and the projectile 29 continue to reside in the mold 53.

[0060] The base 45 may be a metal, such as brass, base, or may be plastic, composite, ceramic, or a combination of materials. A plastic or composite base 45 is preferably molded separately from the molding operation in which the cartridge casing body 23 is molded, before attachment to the cartridge casing body. The base 45 may be attached to the cartridge casing body 23 by any suitable attachment arrangement technique, such as through a mechanical attachment wherein interconnecting components of the base and the cartridge casing body are fitted together, or by any other suitable technique or combination of techniques. The base 45 may, for example, be attached to the cartridge casing body 23 by an attachment arrangement involving the screwing together of threads on the base with threads on the cartridge casing body.

The base **45** may be attached to the cartridge casing body **23** by an attachment arrangement technique involving connecting a tongue and groove arrangement between attachable portions of the base and the cartridge casing body. The base **45** may be attached to the cartridge casing body **23** by an attachment arrangement technique involving forming an interference fit between the cartridge casing body and the base. The base **45** may be attached to the cartridge casing body **23** by an attachment arrangement technique involving adhesive joining. The base **45** may be attached to the cartridge casing body **23** by an attachment arrangement technique involving heat bonding. The base **45** may be attached to the cartridge casing body **23** by an attachment arrangement technique involving ultrasonic welding.

[0061] Another embodiment of an ammunition article **121** according to the present invention is shown in an exploded view in FIG. **16** but, when assembled, can appear substantially the same as the ammunition article **21** illustrated in FIGS. **1-3**. As seen in FIG. **17**, the ammunition article **121** includes a cartridge casing body **123** having a first end **125** and a second end **127**. A projectile **129** is attached to the first end **125** of the cartridge casing body **123**. A base **131**, seen in FIGS. **18A-19**, is preferably formed as a single piece of molded plastic, or from a ceramic, a composite, or a combination of plastic, composite, or ceramic, such as, for example, by starting with a ceramic liner **131_m** and molding a composite or plastic material **131_m** over the ceramic liner, as seen in FIG. **18B**. The base **131** may also incorporate the composite reinforced ceramic technology disclosed in U.S. patent application Ser. No. 08/590,621, which is hereby expressly incorporated by reference. As seen in FIG. **17**, the base **131** is attached to the second end of the cartridge casing body. In this embodiment, the cartridge casing body **123** may be a plastic cartridge casing body, such as the plastic cartridge casing body described in connection with FIGS. **1-15**, or a metallic cartridge casing body, such as a brass body in which a projectile is installed, as seen in FIG. **20**, or which is for a blank cartridge, or a suitable ceramic, composite, or other desired material. The cartridge casing body **123** may also be made of a moldable material that forms part of the propellant pack, i.e., a moldable propellant, or otherwise is itself combustible or consumable by a propellant such as a powder ignition.

[0062] A propellant charge is preferably provided inside the cartridge casing body **123** and, as seen in FIG. **17**, a device for igniting the propellant, such as a primer **133** or an electronic ignition may be provided, or partially provided, for igniting the propellant. Although the base **131** is a plastic base, the base is preferably made of a sufficiently sturdy material to be reusable although the cartridge casing body **123** may be replaceable. The base **131** is attached to the cartridge casing body **123** by any suitable attachment arrangement **135**. The attachment arrangement **135** may, for example, be a mechanical attachment arrangement wherein portions of the base **131** and the cartridge casing body **123** interconnect with each other. Suitable attachment arrangements **135** include screw thread arrangements wherein the base **131** is attached to the cartridge casing body **123** by screw threads, tongue and groove arrangements, an interference fit the cartridge casing body, adhesive, a heat bond, and an ultrasonic weld.

[0063] The ammunition article **121** is preferably made according to a method as seen in FIG. **21** wherein plastic is molded in a mold **137** around one or more cores **139** to form the single piece, molded plastic base **131**. The mold **137** may

have two, substantially symmetrical halves, as seen in FIG. **21**, that separate in a direction transverse to a longitudinal axis of the base **131**, the mold may have two parts that separate in a direction of a longitudinal axis of the base, or the mold may have a single component, with the core **139** closing an end of the single component mold and one or both of the core and the single component mold being movable to permit removal of the base. If desired or necessary, the cartridge casing body or an ignition device or some component of an ammunition article may form part or all of a core around which the base **131** is molded. As seen in FIGS. **16** and **17**, preferably after molding, the base **131** is attached to the second end **127** of the cartridge casing body **123** using a suitable attachment arrangement **135**. The cartridge casing body **123** may be a molded plastic cartridge casing body, such as the body described with reference to FIGS. **1-15**, which is preferably formed in a separate operation from the molding of the base **131**, or a metallic cartridge casing body, such as the body shown in FIG. **20**. Preferably, before attachment of the base **131** and the cartridge casing body **123**, a propellant is provided in the cartridge casing body. A device for igniting the propellant may be provided or partially provided, such as a primer **133** or an electronic ignition, and may be attached or partially attached to the base **131** depending upon the nature of the device.

[0064] Another embodiment of an ammunition article **221** according to the present invention is shown in FIG. **22**. The ammunition article **221** is particularly well-suited for use as a blank cartridge. The ammunition article **221** includes a molded plastic cartridge case body **223** having a closed front end **225** and a second end **227**. Although the ammunition article **221** is illustrated as having a convex front end **225**, it will be appreciated that the front end can be any shape desired or necessary, such as flat, convex, or whatever shape yields desired characteristics.

[0065] As seen in FIG. **23**, the ammunition article **221** is preferably molded in a mold **229** around a core pull **231**. The core pull **231** and the mold **229** are preferably shaped such that the closed front end **225** preferably includes walls that reduce in thickness toward an axial center **233** of the closed front end to facilitate causing the ammunition article to break at the tip and minimize the potential for portions of the wall becoming projectiles. Moreover, the closed front end **225** preferably includes at least one, preferably a plurality of stress concentrators **235** for causing preferential tearing of the closed front end at the stress concentrators such that, upon firing, the front end will tend to split open at the axial tip at the center **233** and permit expansion of a charge, preferably a charge consisting of an explosive charge, such as black powder or PYRODEX, a smokeless black powder substitute available from Hodgdon Powder Co., Inc., Shawnee Mission, Kans. If desired or necessary, another propellant charge may be used.

[0066] As seen in FIG. **24-26**, the core pull **231** preferably has raised portions **237** for forming the stress concentrators **235**. The raised portions **237** are preferably in the form of intersecting lines that intersect at the tip **239** of the core pull **231** such that the resulting shape of the stress concentrators **235** on the interior wall of the front portion **225** of the cartridge casing body **223** will be such that the cartridge casing body will split open along the stress concentrators at the center **233** and along the length of the stress concentrators, reducing the possibility of portions of the cartridge casing body becoming projectiles upon expansion of a powder

charge. If desired or necessary, stress concentrators can be provided on an exterior surface of the cartridge casing body 223 in addition to or instead of the stress concentrators 235 on the interior surface of the front portion 225, preferably by providing appropriately shaped raised portions on the mold 229.

[0067] As with the cartridge casing body 23, a base 241 (shown in phantom in FIG. 22) like the base 45 is preferably attached to the cartridge casing body 223 by one or more of the same attachment arrangements, and a propellant (not shown) and a powder charge ignition device (not shown) are preferably also provided. The base may be a reusable base, and the cartridge casing body 223 is preferably replaceable on the base.

[0068] As seen in FIGS. 23 and 27, the cartridge casing body 223 is preferably formed by molding plastic around the core pull 231 to form the molded plastic cartridge case body 223 having a closed front end 225 and a second end 227. The core pull 231 is removed from the cartridge casing body 223 after the plastic is molded around the core pull. The mold 229 is preferably a two-piece mold (one piece of which is shown in FIG. 23) that separates along a plane extending through a longitudinal axis of the cartridge casing body, and at least one of the mold and the core pull 231 is movable relative to the other such that the core pull can be removed along the longitudinal axis of the cartridge casing body.

[0069] Yet another embodiment of an ammunition article 321 is shown in an exploded view in FIG. 28. The ammunition article 321 includes a molded plastic cartridge case body 323. The cartridge case body 323 includes a web 325 dividing an internal volume of the body to define a lower cavity 327 for receiving a propellant and an upper cavity 329 for receiving a projectile 331. The web 325 includes an upwardly extending prong 333 for being received in a corresponding recess 335 in a base 337 of the projectile 331 to fasten the cartridge casing body 323 to the projectile. The prong 333 may be attached in the recess 335 by any suitable attachment arrangement and attachment technique, such as by an interference fit, by interlocking structures on the prong and the recess, by an adhesive, by heat bonding, and by ultrasonic welding. The cartridge casing body 323 may, of course, be molded around the projectile 331 in a manner similar to the manner in which the cartridge casing body 23 is molded around the projectile 29, except that a core pull would not extend all the way to a base of the projectile. The prong 333 may be formed by causing plastic to enter the recess 333 during the molding operation.

[0070] Alternatively, the cartridge casing body 323 may be formed in a separate molding operation and thereafter attached to the projectile 331 such that the prong 333 is caused to enter the recess 335. A base (not shown) may be attached by a suitable attachment arrangement in the same way that the base 45 is attached to the cartridge casing body 23, and a propellant charge (not shown) and a propellant ignition device (not shown) may be provided in the same way as with the ammunition article 21. U.S. Pat. No. 5,033,386 and U.S. Pat. No. 5,151,555 disclose plastic cartridge cases having a web extending across a body of the cartridge cases and are hereby expressly incorporated by reference.

[0071] FIG. 29 discloses yet another embodiment of an ammunition article 321' including a plastic cartridge casing body 323'. The body 323' is molded to conform with a bottom end 325' of the projectile in which a recess 327' is provided such that a protrusion 329' is molded in the recess and, preferably, the walls of the body do not extend up the sides of the

projectile. This embodiment of the ammunition article 321' facilitates use of a combustible cartridge casing body 323', such as where the cartridge casing body itself forms part of the propellant pack. Where the cartridge casing body 323' is intended to be part of the propellant pack, the base is preferably adapted to expand during firing to form a gas seal. As desired or necessary, the base may be a metal base, such as a brass base, or a plastic material base, a ceramic base, a composite base, a combination of plastic, composite, or ceramic, or may incorporate the composite reinforced ceramic technology disclosed in U.S. patent application Ser. No. 08/590,621, which is expressly incorporated by reference.

[0072] Yet another embodiment of an ammunition article 421 according to the present invention comprises a projectile 423 having cannellure contours 425 and a molded cartridge casing body 427 molded around at least a portion of the projectile such that a portion 429 of a wall 431 of the cartridge casing body follows the cannellure contours of the projectile. The portion 429 of the wall 431 preferably has a substantially constant thickness such that, where the projectile is recessed, the portion of the wall is also recessed.

[0073] The foregoing embodiments of the present invention are all believed to be useful for use with all types of cartridges or blanks, regardless of shape. For example, in all of the embodiments, the cartridge casing body may be, for example, cylindrical, bottle-shaped, or have other suitable shapes as desired or necessary.

[0074] While this invention has been illustrated and described in accordance with a preferred embodiment, it is recognized that variations and changes may be made therein without departing from the invention as set forth in the claims and equivalents thereof.

What is claimed is:

1. A cartridge casing body for an ammunition article, the cartridge casing body comprising:
 - a first end and a second end;
 - an attachment device at the first end of the cartridge casing body, the attachment device being adapted to secure a projectile to the first end of the cartridge casing body, wherein the attachment device is selected from the group consisting of a heat bond, an adhesive, an ultrasonic weld, and at least one flange;
 - a base at the second end of the cartridge casing body; and
 - an internal volume divided into a lower cavity for holding a propellant and an upper cavity for receiving the projectile;
 wherein the base and the cartridge casing body are made from plastic, ceramic, or a composite material and wherein only a portion of the projectile is within the cartridge casing body.
2. The cartridge casing body of claim 1, wherein the base is made from plastic, wherein the attachment device is at least one flange, the flange extending from the cartridge casing body into the projectile.
3. The cartridge casing body of claim 1, wherein the base is made from ceramic, wherein the attachment device is at least one flange, the flange extending from the cartridge casing body into the projectile.
4. The cartridge casing body of claim 1, wherein the base is made from a composite material, wherein the attachment device is at least one flange, the flange extending from the cartridge casing body into the projectile.
5. The cartridge casing body of claim 1, wherein the base and the cartridge casing body are made of the same material,

wherein the attachment device is at least one flange, the flange extending from the cartridge casing body into the projectile.

6. An ammunition article, comprising:

a cartridge casing body having a first end and a second end; an attachment device at the first end of the cartridge casing body;

a projectile secured to the first end of the cartridge casing body with the attachment device such that only a portion of the projectile is within the cartridge casing body, wherein the attachment device is selected from the group consisting of a heat bond, an adhesive, an ultrasonic weld, and at least one flange;

the cartridge casing body further comprising an internal volume for holding a propellant;

a propellant in the internal volume; and

a base at the second end of the cartridge casing body;

wherein the base and the cartridge casing body are made from plastic, ceramic, or a composite material.

7. The ammunition article of claim 6, wherein the base is made from plastic, wherein the attachment device is at least one flange, the flange extending from the cartridge casing body into the projectile.

8. The ammunition article of claim 6, wherein the base is made from ceramic, wherein the attachment device is at least one flange, the flange extending from the cartridge casing body into the projectile.

9. The ammunition article of claim 6, wherein the base is made from a composite material, wherein the attachment device is at least one flange, the flange extending from the cartridge casing body into the projectile.

10. The ammunition article of claim 6, wherein the base and the casing body are made of the same material, wherein the attachment device is at least one flange, the flange extending from the cartridge casing body into the projectile.

11. The cartridge casing body of claim 1, wherein the attachment device is at least one flange, the flange extending from the cartridge casing body into the projectile, the flange being received by a recess in the projectile.

12. The ammunition article of claim 6, wherein the attachment device is at least one flange, the flange extending from the cartridge casing body into the projectile, the flange being received by a recess in the projectile.

* * * * *