



(51) International Patent Classification:

E02F 9/28 (2006.01) *E21C 35/183* (2006.01)
A01B 15/00 (2006.01) *E21B 10/46* (2006.01)
A01B 23/02 (2006.01) *E21C 35/18* (2006.01)

(21) International Application Number:

PCT/US2017/017631

(22) International Filing Date:

13 February 2017 (13.02.2017)

(25) Filing Language:

English

(26) Publication Language:

English

(30) Priority Data:

15/048,484 19 February 2016 (19.02.2016) US

(71) Applicant: **CATERPILLAR INC.** [US/US]; 100 N.E. Adams Street, Peoria, IL 61629-9510 (US).

(72) Inventors: **KOKOS, George, B.**; 11715 N. Bristol Drive, Dunlap, IL 61525 (US). **BARLOW, James, O.**; 905 Woodland Knolls Road, Metamora, IL 61548 (US). **MA-JEWSKI, Thomas**; 210 E. Surrey Lane, East Peoria, IL 61611 (US). **YANIAK, Thomas**; 609 Evergreen Drive, Washington, IL 61571 (US). **DEAN, Adam, M.**; 261 E. Hazelwood Street, Morton, IL 61550 (US). **TASOVSKI, Vasil**; 3467 Fitzsimmons Cmn., Fremont, CA 94538 (US).

(74) Agents: **LUNDQUIST, Steve, D.** et al.; CATERPILLAR INC., 100 N.E. Adams St. - AH9510, Peoria, IL 61629-9510 (US).

(81) Designated States (unless otherwise indicated, for every kind of national protection available): AE, AG, AL, AM, AO, AT, AU, AZ, BA, BB, BG, BH, BN, BR, BW, BY, BZ, CA, CH, CL, CN, CO, CR, CU, CZ, DE, DJ, DK, DM, DO, DZ, EC, EE, EG, ES, FI, GB, GD, GE, GH, GM, GT, HN, HR, HU, ID, IL, IN, IR, IS, JP, KE, KG, KH, KN, KP, KR, KW, KZ, LA, LC, LK, LR, LS, LU, LY, MA, MD, ME, MG, MK, MN, MW, MX, MY, MZ, NA, NG, NI, NO, NZ, OM, PA, PE, PG, PH, PL, PT, QA, RO, RS, RU, RW, SA, SC, SD, SE, SG, SK, SL, SM, ST, SV, SY, TH, TJ, TM, TN, TR, TT, TZ, UA, UG, US, UZ, VC, VN, ZA, ZM, ZW.

(84) Designated States (unless otherwise indicated, for every kind of regional protection available): ARIPO (BW, GH, GM, KE, LR, LS, MW, MZ, NA, RW, SD, SL, ST, SZ, TZ, UG, ZM, ZW), Eurasian (AM, AZ, BY, KG, KZ, RU, TJ, TM), European (AL, AT, BE, BG, CH, CY, CZ, DE, DK, EE, ES, FI, FR, GB, GR, HR, HU, IE, IS, IT, LT, LU, LV, MC, MK, MT, NL, NO, PL, PT, RO, RS, SE, SI, SK, SM, TR), OAPI (BF, BJ, CF, CG, CI, CM, GA, GN, GQ, GW, KM, ML, MR, NE, SN, TD, TG).

[Continued on next page]

(54) Title: GROUND ENGAGING WEAR MEMBER

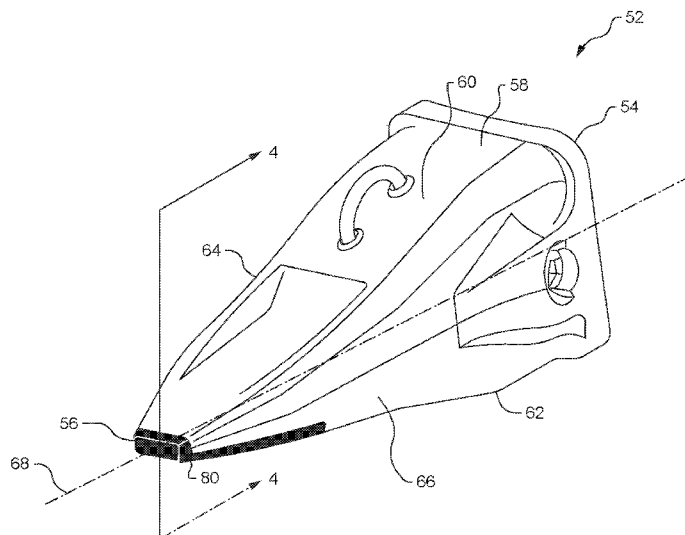
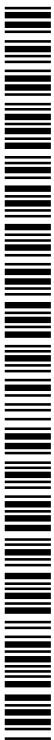

FIG. 3

(57) Abstract: A ground engaging tooth (52) for a ground engaging machine (20) is disclosed. The ground engaging tooth (52) may comprise a non-ground-engaging end (54), a ground-engaging end (56), a body (58) extending between the non-ground-engaging end (54), the ground-engaging end (56), a top surface (60), a bottom surface (62), a left surface (64) and a right surface (66). Further, the ground engaging tooth (52) may comprise a coupling side including a pocket (76) configured to receive a retaining device (78). Moreover, the ground engaging tooth (52) may comprise a wear side including an integral-wear-insert (80). The integral-wear-insert (80) may longitudinally extend along the bottom surface (62) towards the ground-engaging end (56) and vertically extend towards the top surface (60) at the ground-engaging end (56).





Published:

— with international search report (Art. 21(3))

— before the expiration of the time limit for amending the claims and to be republished in the event of receipt of amendments (Rule 48.2(h))

-1-

GROUND ENGAGING WEAR MEMBERDescription5 Technical Field

This disclosure generally relates to a ground engaging machine and, more particularly, to a ground engaging tooth for a ground engaging machine.

Background

Ground engaging machines, such as hydraulic mining shovels,
10 draglines, electric rope shovels, excavators, track-loaders, bulldozers, skid-steer
loaders, backhoe loaders and wheel loaders, are used in a variety of industries
including, but not limited to, construction, agriculture and mining. Generally
speaking, these machines include a frame, a power source supported by a frame,
one or more motive devices operatively associated with the power source
15 configured to transfer energy of the power source to ground and a work implement.
In many instances the work implement may be a bucket configured to hold and
carry a material the ground engaging machine is working on.

The material the ground engaging machine is working on may come
in a variety of levels of hardness, compactness and abrasiveness. For example, the
20 ground engaging machine may work on relatively soft, non-compacted and slightly
abrasive, loamy soil or loose sand. Alternatively, and near the other end of the
spectrum, the ground engaging machine may be called to work on hard, compacted
and highly abrasive, tar, sand or concrete. In any event, as the level of hardness,
compactness and abrasiveness increases, the ground engaging machine may utilize
25 a ground engaging tooth (“GET”) positioned along an engagement edge of the
work implement to penetrate the material worked on, thereby increasing
productivity and decreasing damage to the work implement.

Although GETs are known, there is still room for improvement.
For example, U.S. Patent No. 5,081,774 (“Kuwano”) discloses a composite

-2-

excavating tooth. More specifically, Kuwano discloses a tooth having a wear-resistant material centrally placed between top and bottom surfaces of the tooth. While Kuwano is arguably an effective and durable design, it may suffer from premature wear since the wear-resistant material is placed between the top and
5 bottom surfaces of the tooth, rather than on a ground engaging surface.

The present disclosure is directed to overcoming one or more problems set forth above and/or other problems associated with the prior art.

Summary

In accordance with one aspect of the present disclosure, a ground
10 engaging tooth for a ground engaging machine is disclosed. The ground engaging tooth may comprise a non-ground-engaging end, a ground-engaging end opposite the non-ground-engaging end and a body. The body may extend between the non-ground-engaging end, the ground engaging end, a top surface, a bottom surface, a left surface and a right surface. Further, the ground engaging tooth may comprise a
15 longitudinal axis that may extend lengthwise through the body. Moreover, the ground engaging tooth may comprise a separation plane. The separation plane may extend through the body orthogonal to the longitudinal axis and may be positioned between the non-ground-engaging end and the ground engaging end. Additionally, the ground engaging tooth may include a coupling side that may extend between
20 the non-ground engaging end, the separation plane, the top surface, the bottom surface, the left surface and the right surface and may include a pocket configured to receive a retaining device. Further, the ground engaging tooth may comprise a wear side that may extend between the ground-engaging end, the separation plane, the top surface, the bottom surface, the left surface and the right surface. The wear
25 side may include an integral-wear-insert that may longitudinally extend along the bottom surface towards the ground-engaging end and vertically extends towards the top surface at the ground-engaging end.

In accordance with another aspect of the present disclosure, a bucket for a ground engaging machine is disclosed. The bucket may comprise a

first member and the first member may include a through-bore about which the bucket may rotate. Further, the bucket may comprise a casing. The casing may extend away from the first member and end at a top edge, a left edge, a right edge and an engagement edge. The casing may be configured to carry a material being worked on. Moreover, the bucket may include a ground engaging tooth. The ground engaging tooth may be fixedly attached to the bucket along the engagement edge and may be configured to engage the material being worked on. The ground engaging tooth may include a wear side extending between a ground-engaging end, a separation plane, a top surface, a bottom surface, a left surface and a right surface. Further, the wear side may include an integral-wear-insert that may longitudinally extend along the bottom surface towards the ground-engaging end and may vertically extend towards the top surface at the ground-engaging end.

In accordance with another embodiment of the present disclosure, a ground engaging machine is disclosed. The ground engaging machine may include a frame, a power source supported by the frame and a motive device operatively associated with the power source configured to transfer energy of the power source to ground. Further, the ground engaging machine may include an arm having a first end and a second end opposite the first end, the first end may be rotatably associated with the frame. Moreover, the ground engaging machine may include a bucket operatively coupled to the second end and the bucket may include an engagement edge. Additionally, the ground engaging machine may include a ground engaging tooth fixedly attached to the bucket along the engagement edge. The ground engaging tooth may be configured to engage the material worked on. Moreover, the ground engaging tooth may include a wear side extending between a ground-engaging end, a separation plane, a top surface, a bottom surface, a left surface and a right surface and the wear side may include a cast-in-place-integral-wear-insert that longitudinally extends along the bottom surface towards the ground-engaging end and vertically extends towards the top surface at the ground-

engaging end. The cast-in-place-integral-wear-insert may have a WearFactor between about 1.5 and about 2.5.

These and other aspects and features of the present disclosure will be more readily understood when read in conjunction with the accompanying
5 drawings.

Brief Description

FIG. 1 is side perspective view of a ground engaging machine constructed in accordance with the present disclosure.

FIG. 2 is a side perspective view of a bucket that may be utilized
10 with the ground engaging machine of FIG. 1 constructed in accordance with the present disclosure.

FIG. 3 is a side perspective view of one example of a ground engaging tooth that may be utilized with the bucket of FIG. 2 and ground engaging machine of FIG. 1 constructed in accordance with the present disclosure.

FIG. 4 is a cross-sectional view of the ground engaging tooth of
15 FIG. 3 along line 3-3 of FIG. 3 constructed in accordance with the present disclosure.

FIG. 5 is a bottom elevation view of the tooth of FIG. 3 constructed in accordance with the present disclosure.

FIG. 6 is side perspective view of another example of a ground engaging tooth that may be utilized with the bucket of FIG. 2 and ground engaging machine of FIG. 1 constructed in accordance with the present disclosure.

FIG. 7 is a cross-sectional view of the ground engaging tooth of
25 FIG. 6 along line 7-7 of FIG. 6 constructed in accordance with the present disclosure.

FIG. 8 is a bottom perspective view of the tooth of FIG. 6 constructed in accordance with the present disclosure.

FIG. 9 is a profile view of one example of a ground engaging tooth that may be utilized with the bucket of FIG. 2 and ground engaging machine of

-5-

FIG. 1 constructed in accordance with the present disclosure after mining oil sand overburden for an extended time period.

FIG. 10 is a profile view of one example of a ground engaging tooth that may be utilized with the bucket of FIG. 2 and ground engaging machine of FIG. 1 that is not constructed in accordance with the present disclosure after mining oil sand overburden on the same ground engaging machine as the ground engaging tooth in FIG. 9 as well as for the same amount of time as the ground engaging tooth in FIG.9.

Detailed Description of the Disclosure

Various aspects of the disclosure will now be described with reference to the drawings, wherein like reference numbers refer to like elements, unless specified otherwise. Referring now to the drawings and with specific reference to FIG. 1, a ground engaging machine constructed in accordance with the present disclosure is shown and generally referred to by the reference numeral 20. The ground engaging machine 20 may include a frame 22 and a power source 24 supported by the frame 22. The power source 24 may be provided in any number of different forms including, but not limited to, Otto and Diesel cycle internal combustion engines, electric motors, and the like. Further, the ground engaging machine may include a motive device 26 operatively associated with the power source 24 configured to transfer energy of the power source 24 to ground. While the motive device 26 depicted is an endless track associated with a track-type machine, the motive device 26 may take other forms, such as a wheel.

Further, the ground engaging machine 20 may include an arm 28. The arm 28 may include a first end 30 and a second end 32 opposite the first end 30. The first end 30 may be rotatably associated with the frame 22. Further, as pictured, the arm 28 may be articulated. Therefore, the arm 28 may comprise a full range of movement wherein the second end 32 of the arm 28 may extend fully away from the first end 30. Alternatively, the second end 32 of the arm 28 may comprise a full range of movement wherein the second end 32 of the arm 28 may

move towards the frame 22 of the ground engaging machine 20 near to the first end 30 of the arm 28.

The ground engaging machine 20 may additionally include a bucket 34. The bucket 34 may be operatively coupled to the second end 32 of the arm 28.

5 For example, while referring to FIG. 1 and 2, it may be seen that bucket 34 may include a first member 36 having a through-bore 38 through which a pin may be used to attach the bucket 34 to the second end 32 of the arm 28. Further, as seen in FIG. 2, the through-bore 38 may define an axis-of-rotation 40 about which the bucket 34 may rotate. Moreover, the bucket may include a casing 42 extending
10 away from the first member 36 and ending at a top edge 44, a left edge 46, a right edge 48 and an engagement edge 50. The casing 42 may be configured to carry a material be worked on by the ground engaging machine 20.

Further, the bucket 34 of the ground engaging machine 20 may include a ground engaging tooth 52. As shown in FIG. 1 and 2, the ground
15 engaging tooth 52 may be fixedly attached to the bucket 34 along the engagement edge 50. The ground engaging tooth 52 may be configured to engage a material to be worked on by the ground engaging machine 20. While the ground engaging machine 20 depicted in FIG. 1 and 2 is a hydraulic mining shovel, the present disclosure is not limited only to hydraulic mining shovels. The present disclosure
20 also finds application with other ground engaging machines 20 such as, but not limited to, draglines, electric rope shovels, excavators, track-loaders, bulldozers, skid-steer loaders, backhoe loaders, wheel loaders and the like.

Turning to FIG. 3, one example of the ground engaging tooth 52 that may be utilized with the bucket 34 of FIG. 2 and the ground engaging machine
25 20 of FIG. 1 is depicted in a perspective view. As shown there, the ground engaging tooth 52 may include a non-ground-engaging end 54 and a ground-engaging end 56 opposite the non-ground-engaging end 54. Further, the ground engaging tooth 52 may include a body 58 extending between the non-ground-engaging end 54, the ground-engaging end 56, a top surface 60, a bottom surface

-7-

62, a left surface 64 and a right surface 66. Further, this example of the ground engaging tooth 52 may include a longitudinal axis 68 extending lengthwise through the body 58.

Referring now to FIG. 4, a cross-sectional view along line 4-4 of FIG. 3 of this example of the ground engaging tooth 52 is depicted. As seen therein, the ground engaging tooth 52 may additionally include a separation plane 70 that extends through the body 58 orthogonal to the longitudinal axis 68 and this separation plane 70 may be positioned between the non-ground-engaging end 54 and the ground-engaging end 56. The separation plane 70 may define a plane that delineates a coupling side 72 of the ground engaging tooth 52 from a wear side 74 of the ground engaging tooth 52.

The coupling side 72 may extend between the non-ground-engaging end 54, the separation plane 70, the top surface 60, the bottom surface 62, the left surface 64 and the right surface 66. The coupling side 72 may include a pocket 76 that is configured to receive retaining device 78 (shown in phantom in FIG. 3) and the retaining device 78 may be configured to fixedly attach the ground engaging tooth 52 along the engagement edge 50 of the bucket 34.

Alternatively, the wear side 74 may be the side of the ground engaging tooth 52 configured to engage the material being worked on by the ground engaging machine 20. The wear side 74 may extend between the separation plane 70, the ground-engaging end 56, the top surface 60, the bottom surface 62, the left surface 64 and the right surface 66. The wear side 74 may include an integral-wear-insert 80 and the integral-wear-insert 80 may longitudinally extend along the bottom surface 62 of the wear side 74 towards the ground-engaging end 56. At the ground-engaging end 56, the integral-wear-insert 80 may vertically extend towards the top surface 60 of the wear side 74.

Turning to FIG. 5, a bottom elevation view of the ground engaging tooth 52 according to FIG. 3 is depicted. As seen therein, the integral-wear-insert 80 may extend between the left surface 64 and the right surface 66 at the ground-

engaging end 56. Further, the integral-wear-insert 80 may extend between the left surface 64 and the right surface 66 moving towards the separation plane 70 along the bottom surface 62. Turning back to the cross-sectional view of FIG. 4, it is seen that the integral-wear-insert 80 may include a longitudinal thickness 82 at the ground-engaging end 56 and a vertical thickness 84 along the bottom surface 62. Further, the vertical thickness 84 of the integral-wear-insert 80 may increase as the integral-wear-insert 80 extends away from the ground-engaging end 56 and towards the separation plane 70.

Additionally, the integral-wear-insert 80 depicted in FIGS. 3-5 may comprise a first material 86 while the remaining body 58 may be a second material 88. For example, the integral-wear-insert 80 may be, but is not limited to, white iron, tungsten carbide or porous aluminum oxide infiltrated with white iron or tungsten carbide. Accordingly, the first material 86 may be selected from a group consisting of, but not limited to, white iron, tungsten carbide and aluminum oxide. On the other hand, the second material 88 comprising the remaining body 58 may be, for example, cast steel or other material. Accordingly, the first material 86 may comprise an abrasion resistance greater than the second material 88. Moreover, in one example of the ground engaging tooth 52 depicted in FIGS. 3-5, the integral-wear-insert comprises between about 5 % by volume and about 15 % by volume of the wear side 74.

Furthermore, the integral-wear-insert 80 may be a cast-in-place-integral-wear-insert 90. More particularly, the first material 86 in solid phase may be placed inside of mold formed in the shape of the ground engaging tooth 52. Moreover, the first material 86 in solid phase may be placed at the ground-engaging end 56 of the wear side 74 of the mold. Subsequently, liquid phase second material 88 may be poured into the mold where the heat of the liquid phase second material 88 may remelt or dissolve a limited amount of the solid phase first material 86, when the first material is white iron or tungsten carbide, forming a continuous cast-in-place-integral-wear-insert 90 that may longitudinally extend

along the bottom surface 62 of the wear side 74 towards the ground-engaging end 56 and towards the top surface 60 of the wear side 74 at the ground-engaging end 56. Further, the cast-in-place-integral-wear-insert 90 may extend between the left surface 64 and the right surface 66 at the ground-engaging end 56 and between the
5 left surface 64 and the right surface 66 moving towards the separation plane 70 along the bottom surface 62.

Turning to FIG. 6, another example of a ground engaging tooth 52 that may be utilized with the bucket 34 of FIG. 3 and the ground engaging machine 20 of FIG. 1 is depicted in a perspective view. As seen there, this ground engaging
10 tooth 52 may also include a non-ground engaging end 54 and a ground-engaging end 56 opposite the non-ground-engaging end 54. Further, this ground engaging tooth 52 may include a body 58 extending between the non-ground-engaging end 54, the ground-engaging end 56, a top surface 60, a bottom surface 62, a left surface 64 and a right surface 66. Further, this example of the ground engaging
15 tooth 52 may include a longitudinal axis 68 extending lengthwise through the body 58. However, as seen in this drawing, this ground engaging tooth 52 may include a first tooth 92 and a second tooth 94 disposed parallel to the first tooth 92 at the ground-engaging end 56.

Referring now to FIG. 7, a cross-sectional view along line 7-7 of
20 FIG. 3 of this example of the ground engaging tooth 52 is depicted. As seen there, this ground engaging tooth 52 may additionally include a separation plane 70 that extends through the body 58 orthogonal to the longitudinal axis 68 and this separation plane 70 may be positioned between the non-ground-engaging end 54 and the ground-engaging end 56. The separation plane 70 may define a plane that
25 delineates a coupling side 72 of the ground engaging tooth 52 from a wear side 74 of the ground engaging tooth 52.

The coupling side 72 of this example of the ground engaging tooth 52 may extend between the non-ground-engaging end 54, the separation plane 70, the top surface 60, the bottom surface 62, the left surface 64 and the right surface 66.

The coupling side 72 may also include a pocket 76 that is configured to receive retaining device 78 (shown in phantom in FIG. 3) and the retaining device 78 may be configured to fixedly attach the ground engaging tooth 52 along the engagement edge 50 of the bucket 34.

5 Referring now to FIGS. 6 and 7, the wear side 74 may be the side of the ground engaging tooth 52 configured to engage the material being worked on by the ground engaging machine 20. The wear side 74 of this example of the ground engaging tooth 52 may extend between the separation plane 70, the ground-engaging end 56, the top surface 60, the bottom surface 62, the left surface 64 and
10 the right surface 66. The wear side 74 may include an integral-wear-insert 80 associated with the first tooth 92 and the integral-wear-insert 80 may longitudinally extend along the bottom surface 62 of the wear side 74 towards the ground-engaging end 56. At the ground-engaging end 56, the integral-wear-insert 80 may vertically extend towards the top surface 60 of the first tooth 92. Additionally, the
15 wear side 74 of this ground engaging tooth may additionally include a second-integral-wear-insert 96 associated with the second tooth 94. Like the integral-wear-insert 80, the second-integral-wear-insert 96 may longitudinally extend along the bottom surface 62 of the wear side 74 towards the ground-engaging end 56. Further, at the ground-engaging end 56, the second-integral-wear-insert 96 may
20 vertically extend towards the top surface 60 of the second tooth 94.

Turning to FIG. 8, a bottom perspective view of the ground engaging tooth 52 according to FIG. 6 is depicted. As seen therein, the integral-wear-insert 80 may extend between the left surface 64 and a first inner surface 98 at the ground-engaging end 56. Further, the integral-wear-insert 80 may extend
25 between the left surface 64 and the right surface 66 moving towards the separation plane 70 along the bottom surface 62. Turning back to the cross-sectional view of FIG. 4, it is seen that the integral-wear-insert 80 may include a longitudinal thickness 82 at the ground-engaging end 56 and a vertical thickness 84 along the bottom surface 62. Further, the vertical thickness 84 of the integral-wear-insert 80

may increase as the integral-wear-insert 80 extends away from the ground-engaging end 56 and towards the separation plane 70.

Turning back to FIG. 8, it is seen that the second-integral-wear-insert 96 may extend between the right surface 66 and a second inner surface 100 at the ground-engaging end 56. Further, the second-integral-wear-insert 96 may extend between the left surface 64 and the right surface 66 moving towards the separation plane 70 along the bottom surface 62. Turning back to the cross-sectional view of FIG. 4, it is to be understood that the right half of this ground engaging tooth 52 mirrors the left-half depicted in the drawing. Accordingly, the second-integral-wear-insert 96 may also include a longitudinal thickness 82 at the ground-engaging end 56 and a vertical thickness 84 along the bottom surface 62. Further, as seen therein, the vertical thickness 84 of the second-integral-wear-insert 96 may increase as the second-integral-wear-insert 96 extends away from the ground-engaging end 56 and towards the separation plane 70.

Additionally, the integral-wear-insert 80 and second-integral-wear-insert 96 depicted in FIGS. 6-8 may comprise a first material 86 while the remaining body 58 may be a second material 88. For example, the integral-wear-insert 80 and the second-integral-wear-insert 96 may be, but is not limited to, white iron, tungsten carbide or porous aluminum oxide infiltrated with white iron or tungsten carbide. Accordingly, the first material 86 may be selected from a group consisting of, but is not limited to, white iron, tungsten carbide and aluminum oxide. On the other hand, the second material 88 comprising the remaining body 58 may be, for example, cast steel or other material. Accordingly, the first material 86 may comprise a abrasion resistance greater than the second material 88. Moreover, in one example of the ground engaging tooth 52 depicted in FIGS. 6-8, both of the integral-wear-insert 80 and the second-integral-wear-insert 96 combined comprise between about 5 % by volume and about 15 % by volume of the wear side 74.

Furthermore, the integral-wear-insert 80 and the second-integral-wear-insert 96 may be a cast-in-place-integral-wear-insert 90. More particularly,

-12-

the first material 86 in solid phase may be placed inside of mold formed in the shape of the ground engaging tooth 52. Moreover, the first material 86 in solid phase may be placed at the ground-engaging end 56 of the wear side 74 of the mold. Subsequently, liquid phase second material 88 may be poured into the mold where the heat of the liquid phase second material 88 may remelt or dissolve a very limited amount of the solid phase first material 86, when the first material is white iron or tungsten carbide, forming a continuous cast-in-place-integral-wear-insert 90 that may longitudinally extend along the bottom surface 62 of the wear side 74 towards the ground-engaging end 56 and towards the top surface 60 of the wear side 74 at the ground-engaging end 56. Further, the cast-in-place-integral-wear-insert 90 may extend between the left surface 64 and the right surface 66 at the ground-engaging end 56 and between the left surface 64 and the right surface 66 moving towards the separation plane 70 along the bottom surface 62.

Industrial Applicability

In general, the present disclosure may find use in many applications including, but not limited to, increasing wear life of a ground engaging tooth 52 used on a bucket 34 of a ground engaging machine 20 used in the construction, agricultural and mining industries. Ground engaging machines 20 with which this disclosure finds usefulness include, but are not limited to, hydraulic mining shovels, draglines, electric rope shovels, excavators, track-loaders, bulldozers, skid-steer loaders, backhoe loaders, wheel loaders and the like. While being useful to any of the machines and industries described above, this disclosure may find particular usefulness with ground engaging machines 20 having a bucket 34 with a ground engaging tooth 52 fixedly attached along the engagement edge 50 of the bucket 34. Further, this disclosure may find usefulness when the ground engaging tooth 52 is used in abrasive environments such as, but not limited to, mining coal, oil sands and other abrasive materials. More particularly, the present disclosure finds usefulness by extending the wear life and improving wear shape of a ground engaging tooth 52 utilized on a bucket 34 of a ground engaging machine 20 used to

mine abrasive materials such as, but not limited to, coal, oil sands and other abrasive materials.

In general, the present disclosure may employ a ground engaging tooth 52 depicted in either FIGS. 3-5 or 6-8 that includes an integral-wear-insert 80. The integral-wear-insert 80 may be positioned on the wear side 74 of the ground engaging tooth 52 and may be made of a first material 86 having abrasion resistance greater than the second material 88 from which the remaining body 58 of the ground engaging tooth 52 is constructed. Further, the integral-wear-insert 80 may longitudinally extend along the bottom surface 62 of the wear side 74 towards the ground-engaging end 56 of the ground engaging tooth 52. Further, the integral-wear-insert 80 may vertically extend towards the top surface 60 of the ground engaging tooth 52 at the ground-engaging end 56. Moreover, the integral-wear-insert 80 may include a vertical thickness 84, and the vertical thickness 84 may increase as the integral-wear-insert moves away from the ground-engaging end 56. This structure leads to a ground engaging tooth 52 having a Wear Factor of between about 1.5 and about 2.5, a level heretofore unseen with a ground engaging tooth 52 lacking the integral-wear-insert 80 as disclosed herein. More specifically, this structure leads to a ground engaging tooth 52 having a Wear Factor of at least 1.72, a level heretofore unseen with a ground engaging tooth 52 lacking the integral-wear-insert 80 disclosed herein.

The Wear Factor may be described by the formula:

$$W_D = W_B/W_I$$

Where:

W_D = the Wear Factor;

W_B = the average tip length loss in millimeters per hour of machine operation of at least three brand new ground engaging teeth that do not utilize the integral-wear-insert disclosed herein after being used on the bucket of a ground engaging machine to mine oil sand overburden for about 725 hours; and

5 W_I = the average tip length loss in millimeters per hour of machine operation of at least three brand new ground engaging teeth that do utilize the integral-wear-insert disclosed herein while simultaneously being used on the same bucket of the same ground engaging machine to mine the same oil sand overburden for about 725 hours.

An example of data used to determine the Wear Factor is depicted in Table 1 below.

TABLE 1

Tip Style	PTA Cladded	Integral-Wear-insert	PTA Cladded	Integral-Wear-insert	PTA Cladded	Integral-Wear-insert
Bucket Position	#1	#2	#3	#4	#5	#6
Hours of Machine Operation	727	727	727	727	727	727
Length of New Tip (mm)	480	495	480	495	480	495
Length of Tip at End of Test (mm)	316	412	288	378	303	385
Length Loss of Tip per Hour of Operation (mm)	0.226	0.114	0.264	0.162	0.243	0.151
Average PTA Cladded Tip Length Loss Per Hour of Machine Operation (mm)	0.245	Wear Factor =			1.72	
Average Integral-Wear-Insert Wear Tip Length Loss Per Hour of Machine Operation (mm)	0.142					

10 In addition to the above, the integral-wear-insert leads to a ground engaging tooth 52 having a heretofore unseen Pitch Factor ranging between about -1.0 and -4.0. More specifically, this structure leads to a ground engaging tooth 52 having a -2.45 Pitch Factor, a level heretofore unseen with a ground engaging tooth 52 lacking the integral-wear-insert 80 disclosed herein.

15 The Pitch Factor may be described by the formula:

$$P_D = P_B/P_I$$

Where:

P_D = the Pitch Factor;

P_B = the average tip pitch of at least three brand new ground engaging teeth that do not utilize the integral-wear-insert disclosed herein after being used on the bucket of a ground engaging machine to mine oil sand overburden for about 725 hours, wherein tip pitch is defined as the angle between the plane of the centerline of the tooth pocket and the plane that extends through the point where the centerline of the tooth pocket meet and the point at the longest end of the tooth; and

P_I = the average tip pitch of at least three brand new ground engaging teeth that do utilize the integral-wear-insert disclosed herein while simultaneously being used on the same bucket of the same ground engaging machine to mine the same oil sand overburden for about 725 hours, wherein tip pitch is defined as the angle between the plane of the centerline of the tooth pocket and the plane that extends through the point where the centerline of the tooth pocket meet and the point at the longest end of the tooth.

An example of data used to determine the Pitch Factor is depicted in Table 2 below.

TABLE 2

Tip Style	PTA Cladded	Integral-Wear-Insert	PTA Cladded	Integral-Wear-Insert	PTA Cladded	Integral-Wear-Insert
Bucket Position	#1	#2	#3	#4	#5	#6
Hours of Machine Operation	727	727	727	727	727	727
Pitch of New Tip (Degrees)	-9.00	-9.00	-9.00	-9.00	-9.00	-9.00
Pitch of Tip at End of Test (Degrees)	0.00	-13.00	0.00	-13.00	0.00	-12.00
Pitch Differential at End of Test (Degrees)	-9.000	4.000	-9.000	4.000	-9.000	3.000
Average PTA Cladded Pitch Differential at End of Test (Degrees)	-9.0000	Pitch Factor =			-2.45	
Average Integral-Wear-Insert Tip Pitch Differential at End of Test (Degrees)	3.6667					

Furthermore, the integral-wear-insert disclosed herein leads to a ground engaging tooth 52 having a heretofore unseen Sharpness Factor ranging between about 1.0 and 3.0. More specifically, this structure leads to a ground engaging tooth 52 having a Sharpness Factor of about 2.03, a level heretofore
5 unseen with a ground engaging tooth 52 lacking the integral-wear-insert 80 disclosed herein.

The Sharpness Factor may be described by the formula:

$$S_D = S_B/S_I$$

Where:

10 S_D = the Sharpness Factor;

S_B = the average tip sharpness of at least three brand new ground engaging teeth that do not utilize the integral-wear-insert disclosed herein after being used on the bucket of a ground engaging machine to mine oil sand overburden for about 725 hours, wherein tip sharpness is defined as the angle at the
15 endpoint of the tip where the top surface intersects with the bottom surface; and

S_I = the average tip sharpness of at least three brand new ground engaging teeth that do utilize the integral-wear-insert disclosed herein while simultaneously being used on the same bucket of the same ground engaging machine to mine the same oil sand overburden for about 725 hours, wherein tip
20 sharpness is defined as the angle at the endpoint of the tip where the top surface intersects with the bottom surface.

An example of data used to determine the Sharpness Factor is depicted in Table 3 below.

TABLE 3

Tip Style	PTA Cladded	Integral-Wear-Insert	PTA Cladded	Integral-Wear-Insert	PTA Cladded	Integral-Wear-Insert
Bucket Position	#1	#2	#3	#4	#5	#6
Hours of Machine Operation	727	727	727	727	727	727
Sharpness of New Tip (Degrees)	35.00	35.00	35.00	35.00	35.00	35.00
Sharpness of Tip at End of Test (Degrees)	79.00	55.00	80.00	58.00	78.00	57.00
Sharpness Differential at End of Test (Degrees)	44.000	20.000	45.000	23.000	43.000	22.000
Average PTA Cladded Tip Sharpness Differential at End of Test (Degrees)	44.0000	Sharpness Factor =			2.03	
Average Integral-Wear-Insert Tip Sharpness Differential at End of Test (Degrees)	21.6667					

FIG. 9 is a profile view of a ground engaging tooth utilizing the integral wear insert described herein after placement on a bucket of a ground engaging machine used to mine oil sand overburden for about 725 hours in order to complete the tests necessary to determine the Wear Factor, the Pitch Factor and the Sharpness Factor. On the other hand, FIG. 10 is a profile view of a prior art ground engaging tooth that does not utilize the integral wear insert described herein placed on the same bucket of the same ground engaging machine to mine the same oil sand overburden for about 725 hours in order to complete the tests necessary to determine the Wear Factor, the Pitch Factor and the Sharpness Factor.

As graphically represented in these figures, the ground engaging tooth of FIG. 9 is longer in length than ground engaging tooth of FIG. 10 thereby leading to the heretofore unseen Wear Factor. Furthermore, as graphically depicted therein, the ground engaging tooth in FIG. 9 has a downward pitch (α) after mining oil sand overburden for about 725 hours, while the ground engaging

-18-

tooth in FIG. 10 lacks any pitch after mining oil sand overburden for about 725 hours thereby leading to the heretofore unseen Pitch Factor. In effect, the pitch (α) in FIG.10 has gone to zero, opposite the starting downward pitch (α), and therefore is not depicted. Moreover, as graphically represented in these figures, the ground
5 engaging tooth in FIG. 9 has a sharpness (β) after mining oil sand overburden for about 725 hours that is smaller than the sharpness (β) of the ground engaging tooth of FIG. 10 after mining oil sand overburden for about 725 hours leading to the heretofore unseen Sharpness Factor.

The above description is meant to be representative only, and thus
10 modifications may be made to the embodiments described herein without departing from the scope of the disclosure. Thus, these modifications fall within the scope of present disclosure and are intended to fall within the appended claims.

Claims

1. A ground engaging tooth (52) for a ground engaging machine (20), comprising:
- 5 a non-ground-engaging end (54);
a ground-engaging end (56) opposite the non-ground-engaging end (54);
- a body (58), the body (58) extending between the non-ground-engaging end (54), the ground engaging end, a top surface (60), a bottom surface
10 (62), a left surface (64) and a right surface (66);
a longitudinal axis (68), the longitudinal axis (68) extending lengthwise through the body (58);
a separation plane (70), the separation plane (70) extending through the body (58) orthogonal to the longitudinal axis (68) and being positioned
15 between the non-ground-engaging end (54) and the ground engaging end;
a coupling side, the coupling side extending between the non-ground engaging end (54), the separation plane (70), the top surface (60), the bottom surface (62), the left surface (64) and the right surface (66), the coupling side including a pocket (76) configured to receive a retaining device (78);
20 a wear side, the wear side extending between the ground-engaging end (56), the separation plane (70), the top surface (60), the bottom surface (62), the left surface (64) and the right surface (66), the wear side including an integral-wear-insert (80), the integral-wear-insert (80) longitudinally extends along the bottom surface (62) towards the ground-engaging end (56) and vertically extends
25 towards the top surface (60) at the ground-engaging end (56).
2. The ground engaging tooth (52) according to claim 1, wherein the integral-wear-insert (80) horizontally extends between the left surface (64) and the right surface (66) at the ground-engaging end (56) and wherein the

integral-wear-insert (80) further horizontally extends between the left surface (64) and the right surface (66) along the bottom surface (62).

3. The ground engaging tooth (52) according to claim 1,
5 wherein the integral-wear-insert (80) includes a longitudinal thickness (82) at the ground-engaging end (56) and a vertical thickness (84) along the bottom surface (62).

4. The ground engaging tooth (52) according to claim 3,
10 wherein the vertical thickness (84) increases as the integral-wear-insert (80) longitudinally extends away from the ground-engaging end (56) towards the separation plane (70).

5. The ground engaging tooth (52) according to claim 1,
15 wherein the integral-wear-insert (80) is a cast-in-place-integral-wear-insert (90).

6. The ground engaging tooth (52) according to claim 1,
wherein the integral-wear-insert (80) comprises a first material (86) and the remaining body (58) comprises a second material (88).
20

7. The ground engaging tooth (52) according to claim 6,
wherein the first material (86) comprises a abrasion resistance greater than the second material (88).

8. The ground engaging tooth (52) according to claim 6,
25 wherein the first material (86) is selected from a group consisting of white iron, tungsten carbide and aluminum oxide.

-21-

9. The ground engaging tooth (52) according to claim 1, wherein the integral-wear-insert (80) comprises between about 5 % by volume and about 15% by volume of the wear side.

5 10. A bucket (34) for a ground engaging machine (20), comprising:
a first member (36), the first member (36) including a through-bore (38) about which the bucket (34) may rotate;

a casing (42), the casing (42) attached to and extending away from
10 the first member (36) and ending at a top edge (44), a left edge (46), a right edge (48) and an engagement edge (50), the casing (42) configured to carry a material being worked on;

a ground engaging tooth (52), the ground engaging tooth (52)
fixedly attached to the bucket (34) along the engagement edge (50) configured to
15 engage the material being worked on, the ground engaging tooth (52) including a wear side extending between a ground-engaging end (56), a separation plane (70), a top surface (60), a bottom surface (62), a left surface (64) and a right surface (66), the wear side including an integral-wear-insert (80) that longitudinally extends along the bottom surface (62) towards the ground-engaging end (56) and
20 vertically extends towards the top surface (60) at the ground-engaging end (56).

11. The bucket (34) according to claim 10, wherein the integral-wear-insert (80) horizontally extends between the left surface (64) and the right surface (66) at the ground-engaging end (56) and further wherein the integral-
25 wear-insert (80) extends between the left surface (64) and the right surface (66) along the bottom surface (62).

12. The bucket (34) according to claim 10, wherein the integral-wear-insert (80) includes a longitudinal thickness (82) at the ground-engaging end

(56) and a vertical thickness (84) along the bottom surface (62) and further wherein the vertical thickness (84) increases as the integral-wear-insert (80) longitudinally extends away from the ground-engaging end (56) towards the separation plane (70).

5

13. The bucket (34) according to claim 10, wherein the integral-wear-insert (80) is a cast-in-place-integral-wear-insert (90).

10 14. The bucket (34) according to claim 13, wherein the cast-in-place-integral-wear-insert (90) comprises a first material (86) and the remaining wear side comprises a second material (88) and further wherein the first material (86) comprises a abrasion resistance greater than the second material (88).

15 15. The bucket (34) according to claim 10, wherein the integral-wear-insert (80) comprises between about 5 % by volume and 15 % by volume of the wear side.

20 16. A ground engaging machine (20), comprising:
a frame (22);
a power source (24) supported by the frame (22);
a motive device (26) operatively associated with the power source (24) configured to transfer energy of the power source (24) to ground;
an arm (28) having a first end (30) and a second end (32) opposite the first end (30), the first end (30) rotatably associated with the frame (22);
25 a bucket (34), the bucket (34) operatively coupled to the second end (32) and including an engagement edge (50);
a ground engaging tooth (52) fixedly attached to the bucket (34) along the engagement edge (50) configured to engage a material worked on, the ground engaging tooth (52) including a wear side extending between a ground-

engaging end (56), a separation plane (70), a top surface (60), a bottom surface (62), a left surface (64) and a right surface (66), the wear side including a cast-in-place-integral-wear-insert (90) that longitudinally extends along the bottom surface (62) towards the ground-engaging end (56) and vertically extends towards the top surface (60) at the ground-engaging end (56), wherein the ground engaging tooth (52) with the cast-in-place-integral-wear-insert (90) has a Wear Factor between about 1.5 and about 3.0.

17. The ground engaging machine (20) according to claim 16, wherein the cast-in-place-integral-wear-insert (90) has a Pitch Factor about -1.0 and about -4.0.

18. The ground engaging machine (20) according to claim 16, wherein the cast-in-place-integral-wear-insert (90) has a Sharpness Factor between about 1.0 and about 3.0.

19. The ground engaging machine (20) according to claim 16, wherein the cast-in-place-integral-wear-insert (90) horizontally extends between the left surface (64) and the right surface (66) at the ground-engaging end (56), wherein the cast-in-place-integral-wear-insert (90) extends between the left surface (64) and the right surface (66) along the bottom surface (62), wherein the cast-in-place-integral-wear-insert (90) includes a longitudinal thickness (82) at the ground-engaging end (56) and a vertical thickness (84) along the bottom surface (62), wherein the vertical thickness (84) increases as the cast-in-place-integral-wear-insert (90) longitudinally extends away from the ground-engaging end (56) towards the separation plane (70), wherein the cast-in-place-integral-wear-insert (90) comprises a first material (86) and the remaining wear side comprises a second material (88) and further wherein the first material (86) comprises a abrasion resistance greater than the second material (88).

-24-

20. The ground engaging machine (20) according to claim 16, wherein the cast-in-place-integral-wear-insert (90) comprises between about 5 % by volume and 15 % by volume of the wear side.

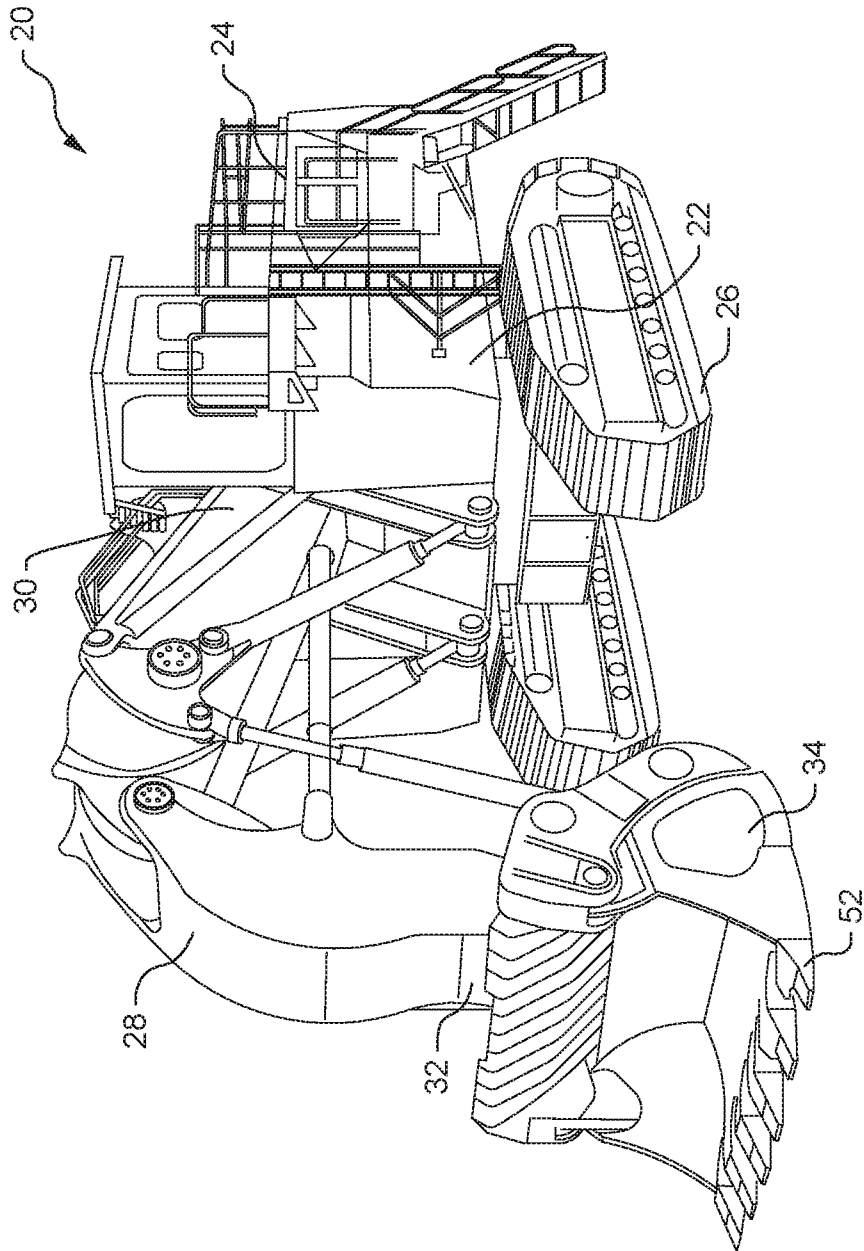

FIG. 1

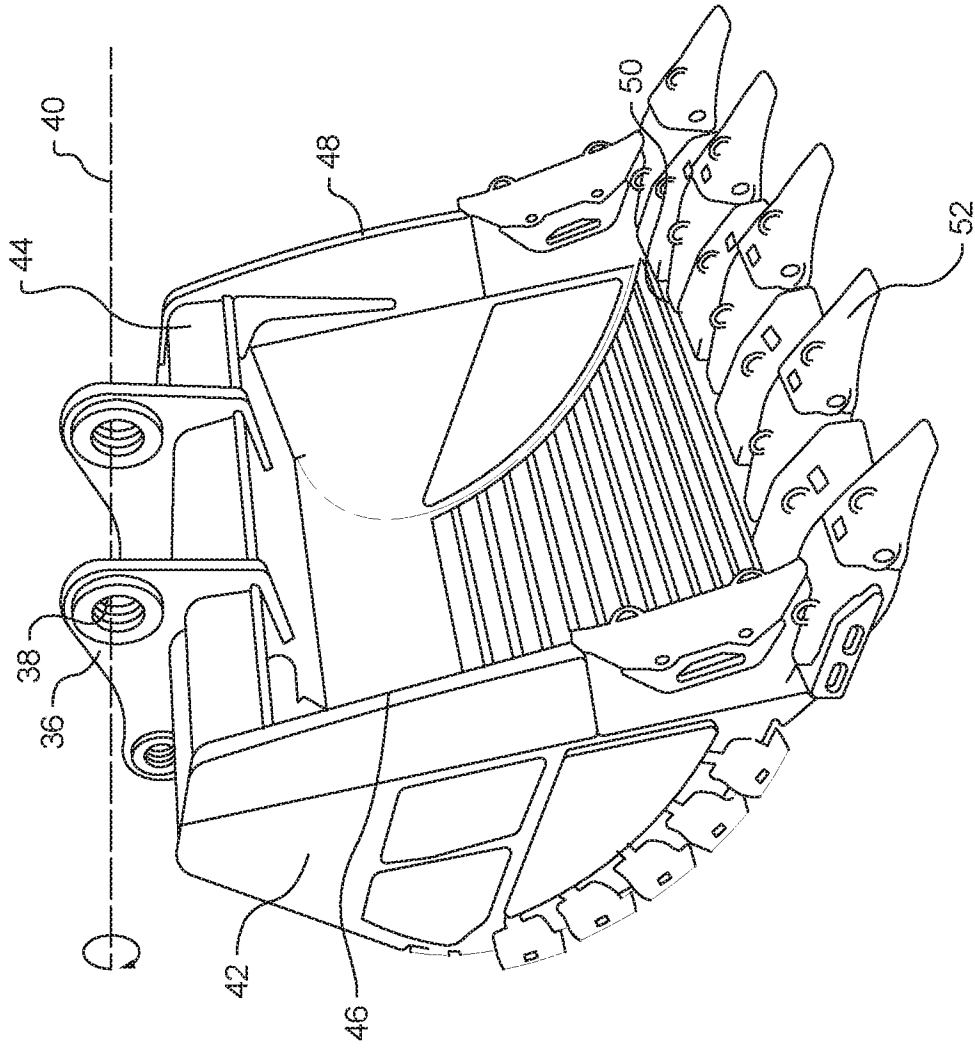

FIG. 2

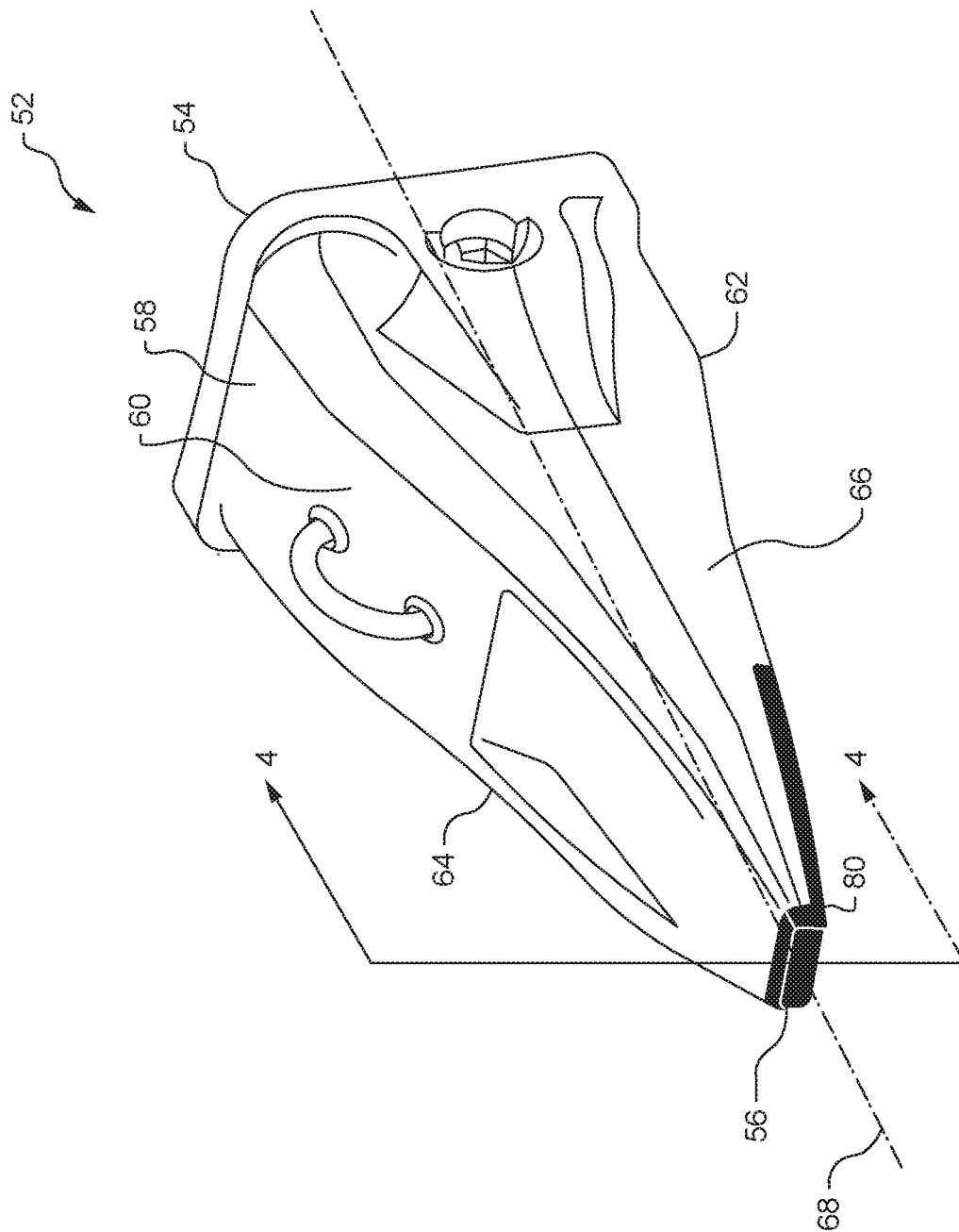

FIG. 3

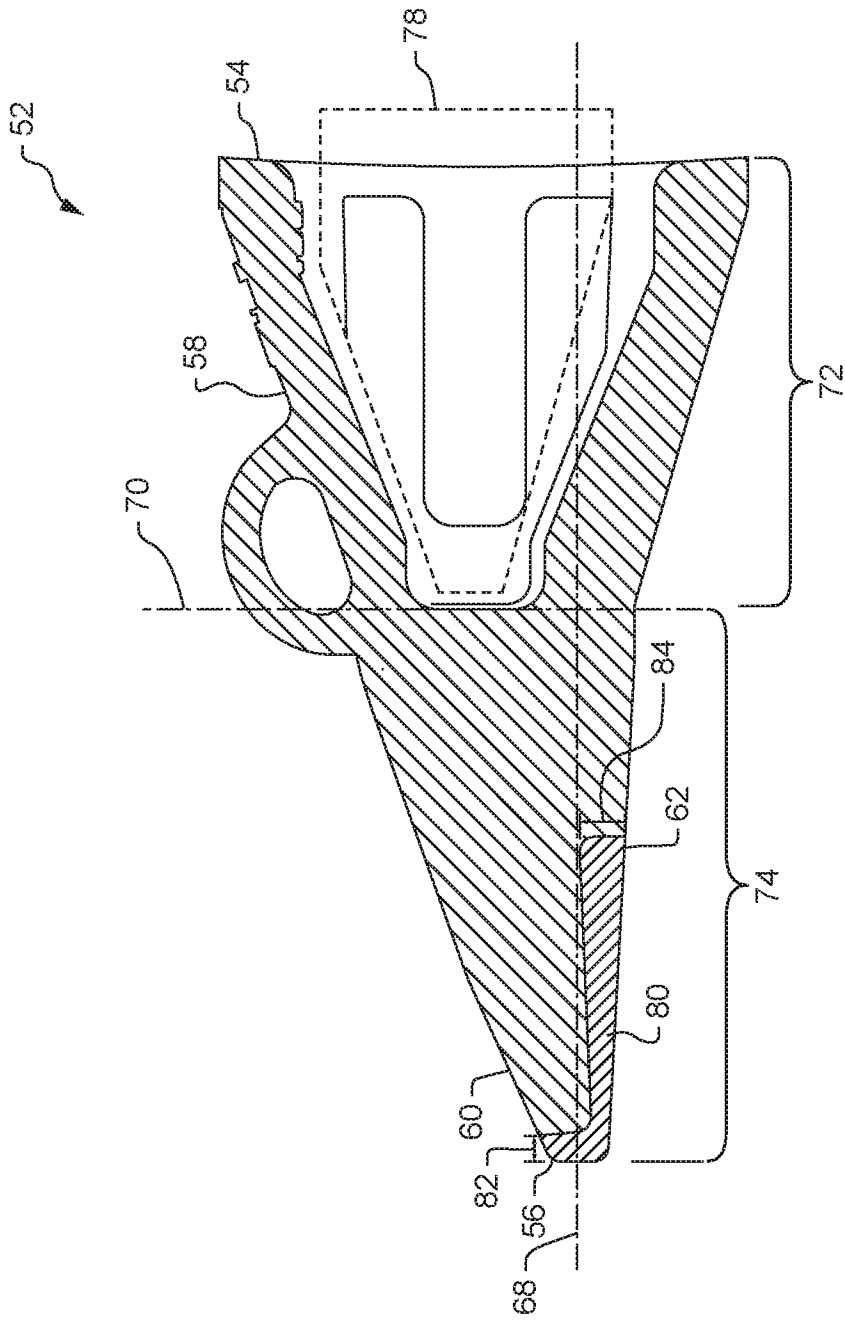

FIG. 4

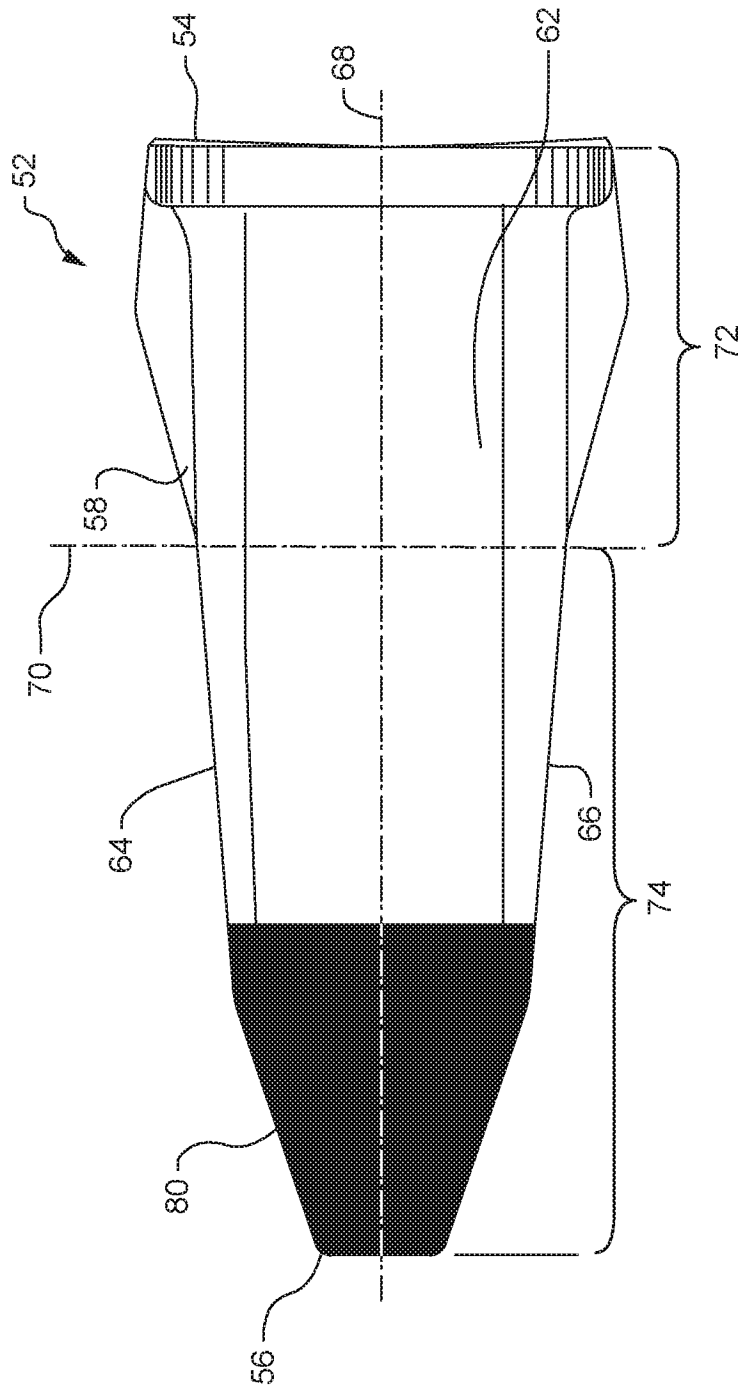

FIG. 5

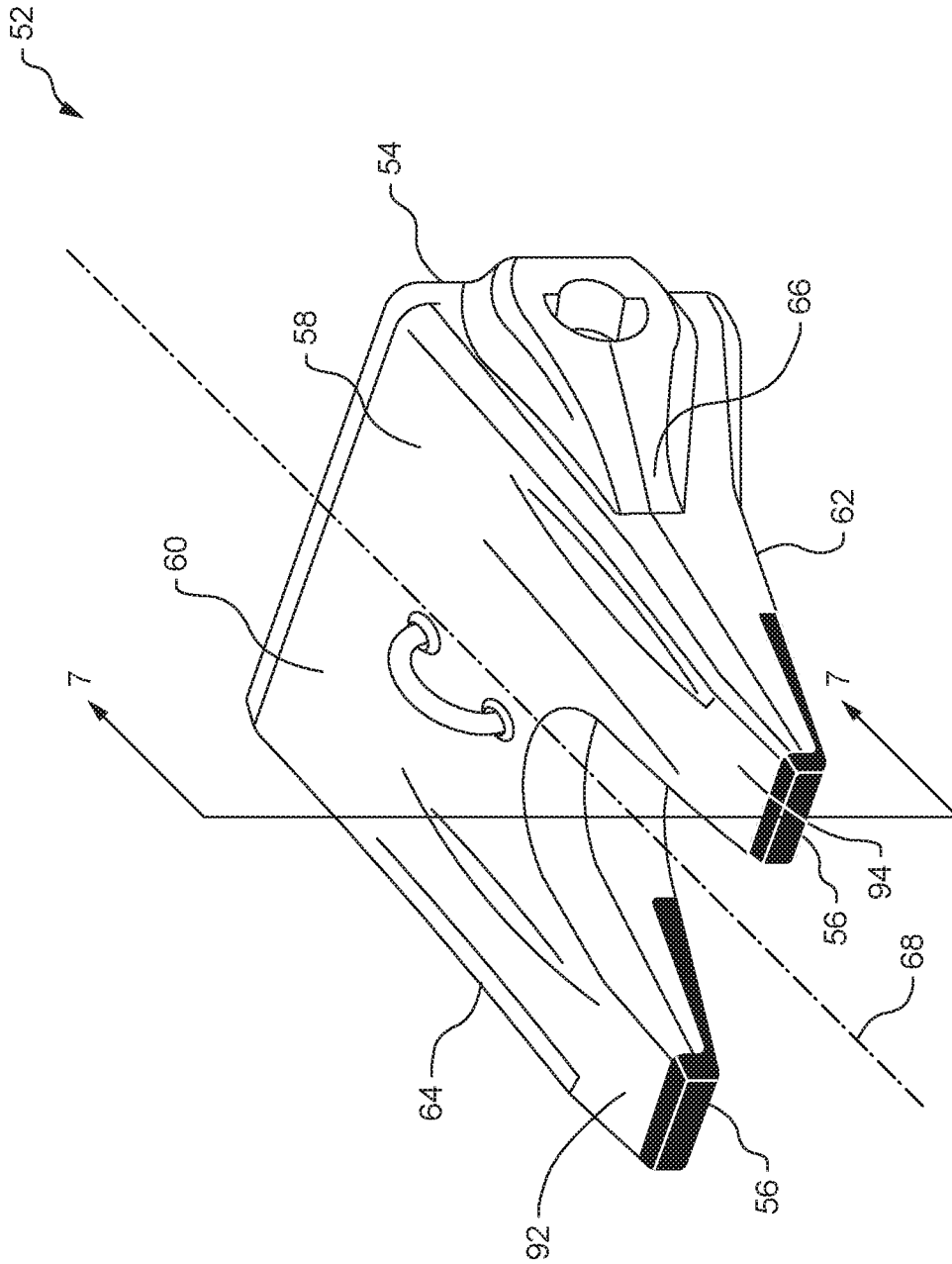

FIG. 6

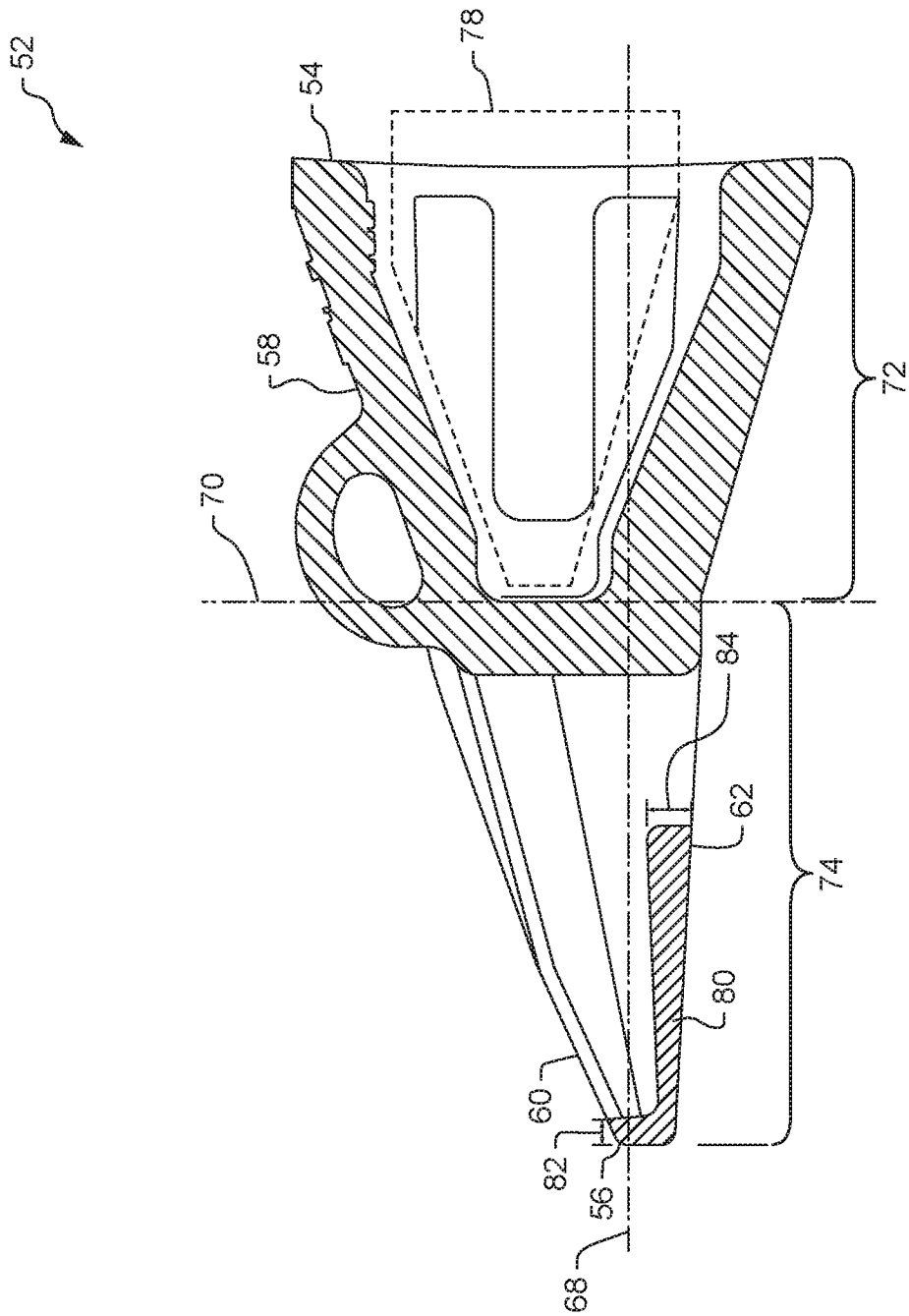

FIG. 7

52

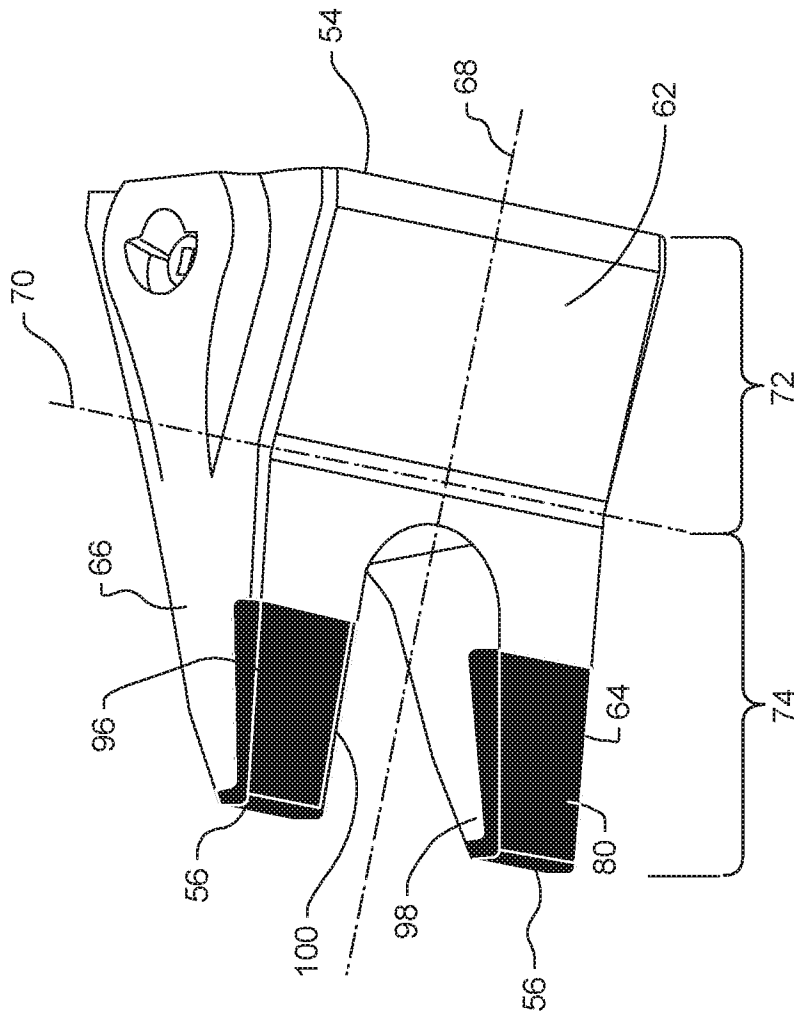

FIG. 8

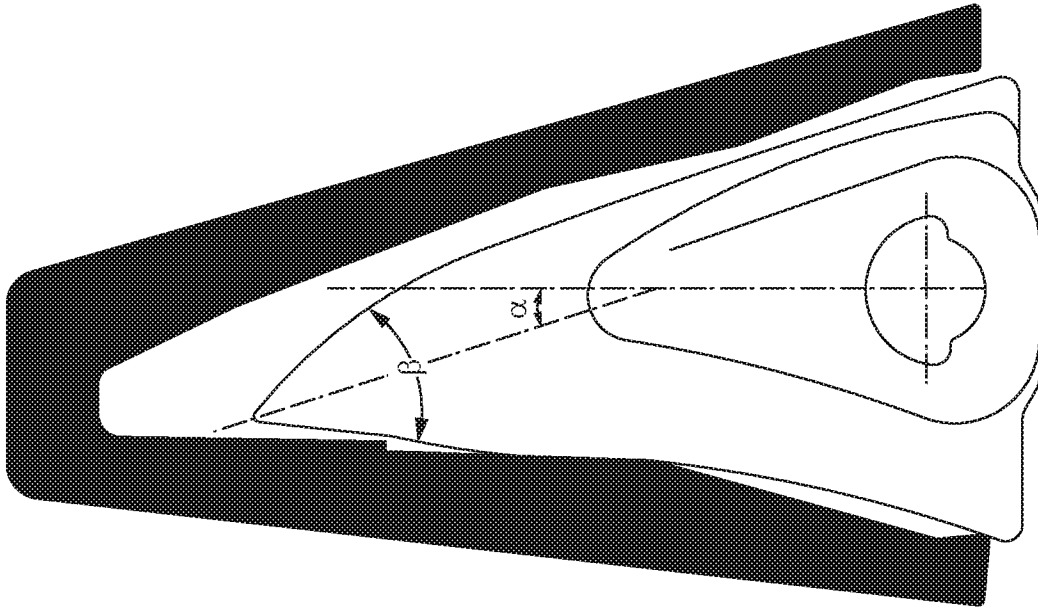

FIG. 9

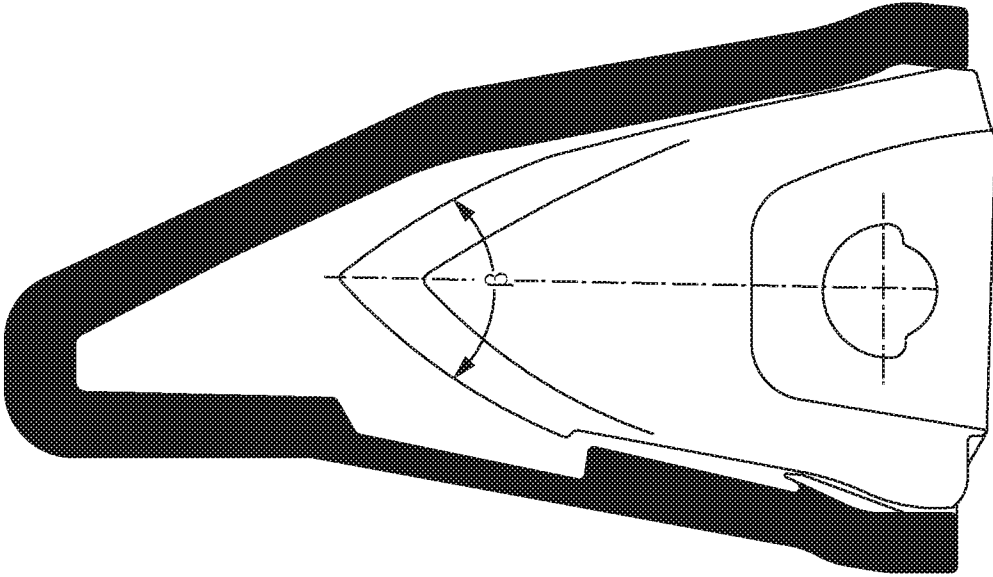

FIG. 10
(PRIOR ART)

INTERNATIONAL SEARCH REPORT

International application No
PCT/US2017/017631

A. CLASSIFICATION OF SUBJECT MATTER
 INV. E02F9/28 A01B15/00 A01B23/02 E21C35/183 E21B10/46
 ADD. E21C35/18

According to International Patent Classification (IPC) or to both national classification and IPC

B. FIELDS SEARCHED
 Minimum documentation searched (classification system followed by classification symbols)
 E02F A01B E21C E21B

Documentation searched other than minimum documentation to the extent that such documents are included in the fields searched

Electronic data base consulted during the international search (name of data base and, where practicable, search terms used)
 EPO-Internal, WPI Data

C. DOCUMENTS CONSIDERED TO BE RELEVANT

Category*	Citation of document, with indication, where appropriate, of the relevant passages	Relevant to claim No.
X	US 5 896 911 A (GEGEL GERALD A [US]) 27 April 1999 (1999-04-27) figures 1-3 -----	1,2,9
X	US 2014/299287 A1 (YANIAK THOMAS JOHN [US] ET AL) 9 October 2014 (2014-10-09) figures 14-15 -----	1,3,4,9
X	US 2010/275473 A1 (MAHER PATRICK [AU]) 4 November 2010 (2010-11-04) figure 3 -----	1
X	JP S59 39461 A (KOMATSU MFG CO LTD) 3 March 1984 (1984-03-03) figure 3 -----	1,3,4,9

Further documents are listed in the continuation of Box C.

See patent family annex.

* Special categories of cited documents :

<p>"A" document defining the general state of the art which is not considered to be of particular relevance</p> <p>"E" earlier application or patent but published on or after the international filing date</p> <p>"L" document which may throw doubts on priority claim(s) or which is cited to establish the publication date of another citation or other special reason (as specified)</p> <p>"O" document referring to an oral disclosure, use, exhibition or other means</p> <p>"P" document published prior to the international filing date but later than the priority date claimed</p>	<p>"T" later document published after the international filing date or priority date and not in conflict with the application but cited to understand the principle or theory underlying the invention</p> <p>"X" document of particular relevance; the claimed invention cannot be considered novel or cannot be considered to involve an inventive step when the document is taken alone</p> <p>"Y" document of particular relevance; the claimed invention cannot be considered to involve an inventive step when the document is combined with one or more other such documents, such combination being obvious to a person skilled in the art</p> <p>"&" document member of the same patent family</p>
---	---

Date of the actual completion of the international search 8 May 2017	Date of mailing of the international search report 06/07/2017
---	--

Name and mailing address of the ISA/ European Patent Office, P.B. 5818 Patentlaan 2 NL - 2280 HV Rijswijk Tel. (+31-70) 340-2040, Fax: (+31-70) 340-3016	Authorized officer Pedersen, Henrik
--	--

INTERNATIONAL SEARCH REPORT

International application No.
PCT/US2017/017631

Box No. II Observations where certain claims were found unsearchable (Continuation of item 2 of first sheet)

This international search report has not been established in respect of certain claims under Article 17(2)(a) for the following reasons:

1. Claims Nos.:
because they relate to subject matter not required to be searched by this Authority, namely:

2. Claims Nos.:
because they relate to parts of the international application that do not comply with the prescribed requirements to such an extent that no meaningful international search can be carried out, specifically:

3. Claims Nos.:
because they are dependent claims and are not drafted in accordance with the second and third sentences of Rule 6.4(a).

Box No. III Observations where unity of invention is lacking (Continuation of item 3 of first sheet)

This International Searching Authority found multiple inventions in this international application, as follows:

see additional sheet

1. As all required additional search fees were timely paid by the applicant, this international search report covers all searchable claims.

2. As all searchable claims could be searched without effort justifying an additional fees, this Authority did not invite payment of additional fees.

3. As only some of the required additional search fees were timely paid by the applicant, this international search report covers only those claims for which fees were paid, specifically claims Nos.:

4. No required additional search fees were timely paid by the applicant. Consequently, this international search report is restricted to the invention first mentioned in the claims; it is covered by claims Nos.:

1-4, 9

Remark on Protest

- The additional search fees were accompanied by the applicant's protest and, where applicable, the payment of a protest fee.
- The additional search fees were accompanied by the applicant's protest but the applicable protest fee was not paid within the time limit specified in the invitation.
- No protest accompanied the payment of additional search fees.

FURTHER INFORMATION CONTINUED FROM PCT/ISA/ 210

This International Searching Authority found multiple (groups of) inventions in this international application, as follows:

1. claims: 1-4, 9

Group I.I containing claims: 1 - 4, 9

The potential special technical features of this group can be summarised as: dimensions of the integral-wear-insert

The technical effects associated with the above features are: integral-wear-insert is located at intended position to be impacted before the rest of the wear member

The objective technical problem solved by this invention could be formulated as: how to improve a wear member?

2. claim: 5

Group I.II containing claims: 5

The potential special technical features of this group can be summarised as: cast-in-place integral-wear-insert

The technical effects associated with the above features are: wear insert is integrated into the wear member by casting

The objective technical problem solved by this invention could be formulated as: how to improve manufacturing of wear member?

3. claims: 6-8

Group I.III containing claims: 6 - 8

The potential special technical features of this group can be summarised as: material characteristic of wear member components

The technical effects associated with the above features are: choose optimum material for the components

The objective technical problem solved by this invention could be formulated as: how to increase lifetime of the integral-wear-part?

4. claims: 10-15

Group II containing claims: 10 - 15

The potential special technical features of this group can be summarised as: a bucket

The technical effects associated with the above features are: containing material

The objective technical problem solved by this invention could be formulated as: how to dig in the ground?

5. claims: 16-20

Group III containing claims: 16 - 20

FURTHER INFORMATION CONTINUED FROM PCT/ISA/ 210

The potential special technical features of this group can be summarised as: a construction machine
The technical effects associated with the above features are: easier, less manual work for workers.
The objective technical problem solved by this invention could be formulated as: how to ease excavation?

INTERNATIONAL SEARCH REPORT

Information on patent family members

International application No

PCT/US2017/017631

Patent document cited in search report	Publication date	Patent family member(s)	Publication date
US 5896911	A	27-04-1999	NONE

US 2014299287	A1	09-10-2014	CN 105228773 A 06-01-2016
			EP 2981374 A1 10-02-2016
			US 2014299287 A1 09-10-2014
			US 2016039001 A1 11-02-2016
			WO 2014165683 A1 09-10-2014

US 2010275473	A1	04-11-2010	AU 2009203887 A1 16-07-2009
			CA 2711148 A1 16-07-2009
			EP 2242886 A1 27-10-2010
			US 2010275473 A1 04-11-2010
			WO 2009086590 A1 16-07-2009
			ZA 201005521 B 28-12-2011

JP S5939461	A	03-03-1984	JP S5939461 A 03-03-1984
			JP S6366633 B2 21-12-1988
