

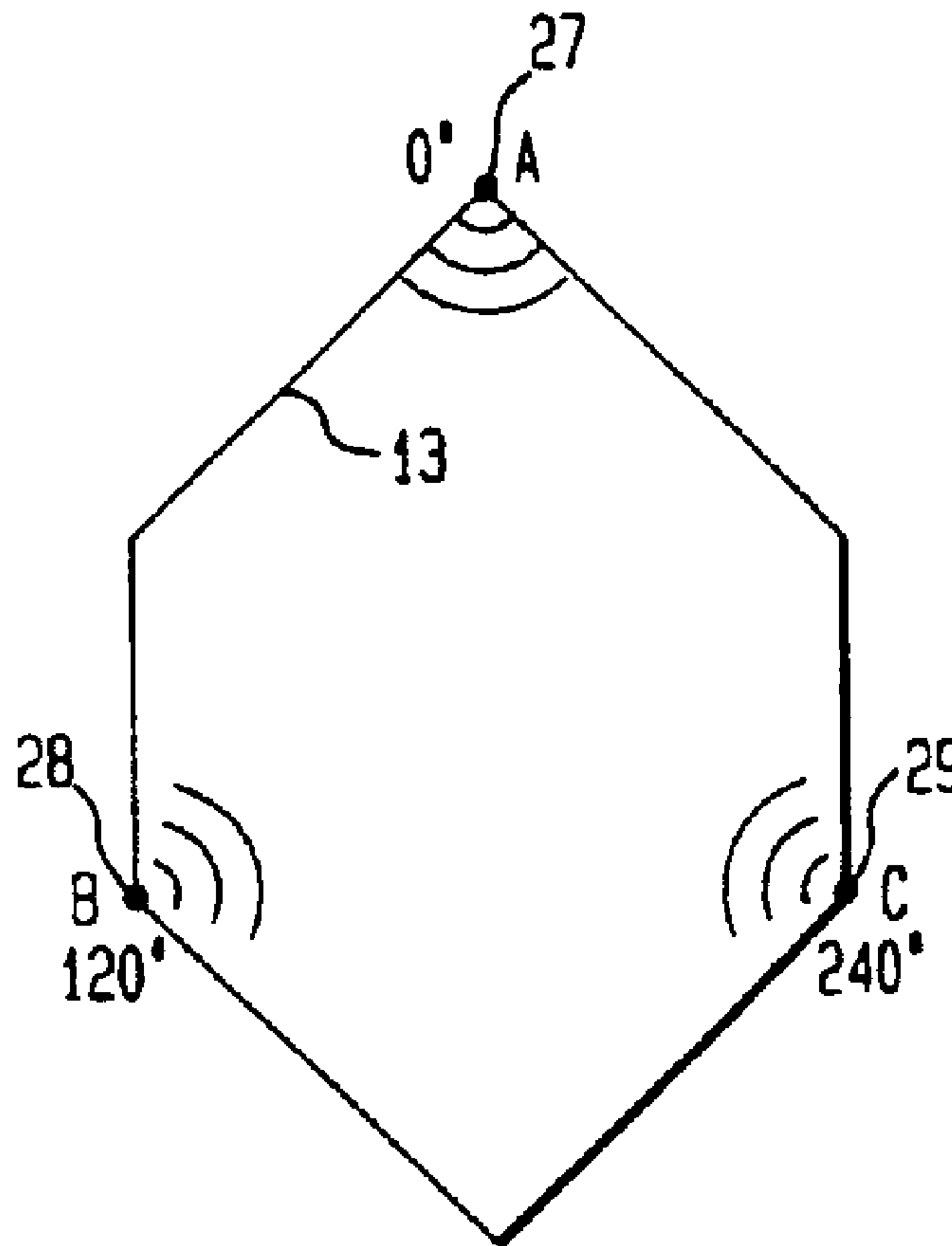

(86) Date de dépôt PCT/PCT Filing Date: 1998/01/08
 (87) Date publication PCT/PCT Publication Date: 1998/08/06
 (45) Date de délivrance/Issue Date: 2003/10/28
 (85) Entrée phase nationale/National Entry: 1999/07/23
 (86) N° demande PCT/PCT Application No.: US 1998/000039
 (87) N° publication PCT/PCT Publication No.: 1998/034424
 (30) Priorité/Priority: 1997/01/30 (08/790,840) US

(51) Cl.Int.⁶/Int.Cl.⁶ H04Q 7/36
 (72) Inventeur/Inventor:
DRIESSEN, PETER F., CA
 (73) Propriétaire/Owner:
AT&T CORP., US
 (74) Agent: KIRBY EADES GALE BAKER

(54) Titre : SYSTEME CELLULAIRE DE TELECOMMUNICATIONS A PLUSIEURS POINTS D'EMISSION SUR UNE MEME FREQUENCE PAR CELLULE
 (54) Title: CELLULAR COMMUNICATION SYSTEM WITH MULTIPLE SAME FREQUENCY BROADCASTS IN A CELL



(57) Abrégé/Abstract:

In a cellular communication network, capacity in a cell is increased by placing antennas transmitting different signals on the same carrier frequency at separated locations in the cell, rather than at the center of the cell. A receiver includes multiple antennas and uses spatial diversity, such as beamforming and cancellation, to extract the desired signal.

ABSTRACT

In a cellular communication network, capacity in a cell is increased by placing antennas transmitting different signals on the same carrier frequency at separated locations in the cell, rather than at the center of the cell. A receiver includes multiple
5 antennas and uses spatial diversity, such as beamforming and cancellation, to extract the desired signal.

CELLULAR COMMUNICATION SYSTEM WITH MULTIPLE SAME FREQUENCY BROADCASTS IN A CELL

BACKGROUND OF THE INVENTION

The present invention relates to cellular communications, and, more particularly, is directed to arrangement of antennas in a cell.

Fig. 1 shows cell 10 of a conventional cellular communication network having a transmitting antenna 20. In fact, the coverage area of antenna 20 has an approximately circular shape, but it is convenient to model the cellular network as formed of hexagonal (rather than circular) cells. Antenna 20 is modelled as being at the center of cell 10, but practically, it may not be precisely centered with respect to the location of other antennas.

As shown in Fig. 2, antenna 20 transmits message A at a carrier frequency f_1 . When the signal to be transmitted comprises time division multiplexed signals A, B, C, the transmission from antenna 20 is as shown in Fig. 3.

Fig. 4 shows receiving apparatus 50, such as a cellular telephone. Antenna 51 receives messages transmitted from antenna 20, and possibly from other antennas in other cells, supplies a received signal to receiver circuit 52, which processes the received signal to extract the message transmitted by antenna 20. Receiver circuit 52 supplies the extracted message to processor 53, which converts the extracted message into a user perceivable signal, such as an audible speech signal, and applies the user perceivable signal to amplifier 54 which is adapted to convert the user perceivable signal into an acoustic signal.

Receiving apparatus 50 may be a pager, in which case the user perceivable signal is a visually displayable signal, and instead of amplifier 54, a display is provided. Alternatively, receiving apparatus 50 may also have transmission capability (not shown).

To increase the traffic carrying capacity of a cell, various schemes are used.

Fig. 5 shows cell 11 having antennas 21, 22, 23 located therein, and transmitting at carrier frequencies f_1 , f_2 , f_3 , respectively. As shown in Fig. 6, each antenna transmits a separate message, indicated as A, B, C. Of course, the signal at each carrier frequency may use a time division multiple access (TDMA) scheme.

5 For example, f_1 may represent messages D, E, F, D, E, F, ..., f_2 may represent messages G, H, G, H, ..., and f_3 may represent messages I, J, K, L, I, J, K, L... The antennas 21, 22, 23 may be a single antenna.

Fig. 7 shows cell 12 having antennas 24, 25, 26 located therein, and each transmitting in a wide bandwidth channel centered at carrier frequency f_1 .

10 However, as shown in Fig. 8, each of the antennas 24-26 uses a distinct modulating code, so that a receiver demodulating its received signal with the same distinct code properly recovers the transmitted message from the intended one of antennas 24-26.

The scheme illustrated in Figs. 7 and 8 is referred to as a spread spectrum scheme, in particular, a code (or carrier) division multiple access (CDMA) scheme. Here,

15 too, the signal transmitted by each of antennas 24-26 may be a time division multiplexed signal.

Edge excited cells have been proposed in which three antennas are located at respective vertices of a hexagonal cell. In known CDMA systems, each of the antennas transmits the same signal. A transmission from a mobile station is

20 received correctly if at least one of the antennas has correctly received the transmission. This configuration of antennas in a cell is also referred to as a corner-fed hexagonal pattern.

Since traffic continues to increase, additional techniques for increasing the traffic carrying capacity of a cell are sought.

25

SUMMARY OF THE INVENTION

In accordance with an aspect of this invention, in a cellular communication

- 3 -

system having a cell with a plurality of signal transmission sites located at k different positions, $k \geq 2$, a plurality of antennas located at the signal transmission sites each transmits one of m signals at the same carrier frequency, $m \geq 2$, so that each of the signals is transmitted from at least one of the k different positions.

5 When there are n antennas located at each of the k different positions, $n = k = m$, and each of the n antennas at each of the k different positions is operative to transmit a respective one of the m signals.

 In accordance with another aspect of this invention, in a cellular communication system, a plurality of antennas in a cell receives at least two signals transmitted from respective antennas of a mobile unit at the same carrier frequency. Each of the antennas supplies the signals which it receives as a respective composite signal to a processor. The processor processes the composite signals to extract a desired one of the transmitted signals.

 The processor extracts one of the transmitted signals by beamforming the composite signals, and cancels the extracted one of the transmitted signals from the composite signals.

 Additionally, receiver circuits coupled to each of the plurality of antennas perform bandpass filtering of the signals received by the antenna coupled thereto.

 In accordance with one aspect of the present invention there is provided a cellular communication system, comprising: a plurality of signal transmission sites located at k different positions in a cell with $k \geq 2$, a plurality of antennas located at the signal transmission sites, each antenna for transmitting one of m signals at the same carrier frequency in the cell with $m \geq 2$, each of the signals being transmitted from at least one of the k different positions, each of the signals representing a data signal devoid of a spreading signal; and a receiving unit located in the cell at a location other than at the plurality of signal transmission sites and having: at least two antennas for receiving the m signals transmitted at the same carrier frequency, and a converter for converting the received signals into an output signal.

-3a-

In accordance with another aspect of the present invention there is provided a method for communicating m respectively different signals having the same carrier frequency in a cell of a cellular communication system, comprising the steps of:

5 providing the m respectively different signals having the same carrier frequency to a plurality of antennas located at k different positions in the cell, each of the signals representing a respective data signal devoid of a spreading signal; transmitting the signals respectively provided to the antennas; and receiving the transmitted signals at a receiving unit located in the cell at a location other than at the k different positions

10 and having: at least two antennas for receiving the transmitted signals, and a converter for converting the transmitted signals into an output signal.

It is not intended that the invention be summarized here in its entirety. Rather, further features, aspects and advantages of the invention are set forth in or are apparent from the following description and drawings.

15

BRIEF DESCRIPTION OF THE DRAWINGS

Fig. 1 is a diagram of a cell in a conventional cellular communication network;

Figs. 2 and 3 are charts depicting transmission from an antenna in the cell of Fig. 1;

Fig. 4 is a diagram of a conventional receiver used in the cell of Fig. 1;

Fig. 5 is a diagram of another cell in a conventional cellular communication network;

Fig. 6 is a chart depicting transmission from antennas in the cell of Fig. 5;

Fig. 7 is a diagram of another cell in a conventional cellular communication network;

Fig. 8 is a chart depicting transmission from antennas in the cell of Fig. 7;

Fig. 9 is a diagram of a cell in a cellular communication network according to the present invention;

Fig. 10 is a chart depicting transmission from antennas in the cell of Fig. 9;

Fig. 11 is a diagram of a receiver according to the present invention used in the cell of Fig. 9;

Fig. 12 illustrates a flowchart of processing performed by the receiver of Fig. 11;

Fig. 13 is a diagram of a cell for use with the flowchart of Fig. 12;

Fig. 14 is a diagram of a cell in a cellular communication network according to the present invention;

Fig. 15 is a chart depicting transmission from antennas in the cell of Fig. 14;

Figs. 16A and 16B illustrate antenna configurations in cells;

Figs. 17-19 illustrate different signal distribution techniques;

Figs. 20-21 are diagrams illustrating addition of antennas to an existing hexagonal cell plan;

Fig. 22 is a diagram illustrating addition of antennas to a rectilinear cell plan; and

Figs. 23-24 are diagrams illustrating different city cell layouts.

DETAILED DESCRIPTION OF THE PREFERRED EMBODIMENTS

Generally, a cell according to the present inventive technique uses a spatial diversity scheme to increase its traffic carrying capacity. Instead of locating multiple antennas at the center of the cell, the antennas are located at k separated positions in the cell, and a receiver in the cell uses k antennas, instead of one antenna. The antennas in the cell transmit m different signals on the same frequency in the cell. The receiver relies on appropriate spatial processing of the signals received from different directions to distinguish the desired signal which is possible because the signals arrive from different directions.

Furthermore, each of k locations may have n antennas, and each of the n antennas at a location transmits one of the m signals. When each of the m signals is transmitted from at least two locations, even if the transmission from one of the locations is blocked, the receiver is still able to receive the desired signal from at least one of the other locations. Using multiple antennas to transmit one signal simulates the effect of scatterers in a single antenna environment.

The present inventive technique may be used when the m signals are unrelated, that is, are separate data streams, and also may be used when the m signal are related, that is, form portions of one data stream. An example of unrelated signals are those from different sending parties to different receiving parties. An example of related signals are portions of a multiplexed data stream.

Referring now to the drawings, and in particular to Fig. 9, there is illustrated cell 13 of a cellular communication network according to the present inventive technique. Cell 13 has directional antennas 27, 28, 29 spaced generally equidistantly around its perimeter, at locations referred to as 0° , 120° and 240° , respectively. Antennas 27, 28, 29 are directional antennas with 120° beamwidth.

Alternatively, instead of antennas 27, 28, 29 being directional, reflectors can be placed behind them to avoid covering the adjacent cells. In other embodiments, at least some of the antennas are located at positions other than the perimeter of the cell. There are at least two antennas per cell.

5 The signal from each of antennas 27-29 is directed towards the center of the cell to reduce the interference from the signals in neighboring cells. As shown in Fig. 10, each of the signals is at a carrier frequency f_1 , and each represents a different signal, indicated as signals A, B, C, respectively. Each signal may be in $\pi/4$ shifted QPSK format. Other signal modulation schemes are also suitable.

10 Fig. 11 shows receiving apparatus 60, such as a cellular telephone. Antennas 61, 62, 63 are adapted to receive signals from antennas 27-29, and possibly from other antennas in other cells and to supply a received signal to receiver circuits 64, 65, 66, respectively.

Each of receiver circuits 64, 65, 66 serves to bandpass filter the signal
15 supplied thereto in a passband centered at f_1 , to amplify the bandpass filtered signal and possibly to downconvert the amplified signal to produce a composite of all signals having a carrier frequency of approximately f_1 , and to supply the thus
obtained composite signal to processor 67. The composite signals from each of
receiver circuits 64-66 have respectively different phases due to the differing
20 positions of antennas 61-63.

Processor 67 is adapted to convert the composite signals into a user
perceivable signal such as an audible speech signal, using a technique described
below, and to apply the user perceivable signal to amplifier 68 which is adapted to
convert the user perceivable signal into an acoustic signal.

25 The signal transmitted by each of antennas 27-29 may be a TDMA signal.

Fig. 12 illustrates a flowchart of how processor 67 converts the composite
signals supplied thereto into a user perceivable signal by applying nulling and

-7-

cancellation processing to separate (or extract) the transmitted signals. It will be recalled that each of antennas 61-63 receives a signal comprising the signals transmitted from antennas 27-29. Some of the transmitted signals may, of course, be blocked by environmental conditions, such as physical bodies or other
5 interference.

At step 110, processor 67 initializes parameter S to be the number of signals, and parameter I to a value of zero. For this example, let it be assumed there is a set of four signals A, B, C, D transmitted at a carrier frequency f_1 from each of four locations (such as $0^\circ, 90^\circ, 180^\circ, 270^\circ$) in a cell, as shown in Fig. 13,
10 so $S = 4$.

Extraction of signal A will now be described.

At step 120, processor 67 increments parameter I ($I = 1$). At step 130, processor 67 tests whether $I = S$. Since I is less than S , processor 67 proceeds to step 140 and tests whether $I = 1$. Since $I = 1$ in this iteration, processor 67
15 proceeds to step 150.

At step 150, processor 67 nulls J signals ($J = 2$ to 4), that is, signals B, C, D , from the composite signal.

Signal nulling is performed by beamforming the composite signals while considering signals B, C, D to be interference signals. Beamforming is described in
20 "Beamforming: a versatile approach to spatial filtering", van Veen, B.D. et al., *IEEE ASSP Magazine*, April 1988, pages 4-24. Beams in the antenna pattern are artificially formed in the direction of each signal, while minimizing the influence of others. Numerical weights by which to multiply the received composite signals are selected to minimize the mean square error (MSE) between the desired signal and the
25 weighted received composite signals. Beamforming in a cellular communication system is discussed in "An Adaptive Array for Mobile Communication Systems",

Anderson, S. et al., *IEEE Trans. Vehicular Tech.*, vol. 40, no. 1, February 1991, Pages 230-236. More general adaptive array processing may be used instead of beamforming, using techniques known to those of ordinary skill.

5 Processor 67 then returns to step 120. At this point, signals B, C, D have been nulled from the composite signal, so what remains is signal A.

Extraction of signal B will now be described.

At step 120, processor 67 increments parameter I ($I = 2$). At step 130, processor 67 tests whether $I = S$. Since I is less than S, processor 67 proceeds to step 140 and tests whether $I = 1$. Since $I = 2$ in this iteration, processor 67
10 proceeds to step 160.

At step 160, processor 67 subtracts the previously extracted signal(s) from the composite signal ($A + B + C + D$). At this point, signal A has been extracted, so the result of the subtraction is an intermediate signal ($B + C + D$).
15 Processor 67 then proceeds to step 170 and nulls J signals ($J = 3$ to 4), that is, signals C, D, from the intermediate signal, as generally described above. What remains after nulling is signal B.

Processor 67 returns to step 120.

Extraction of signal C will now be described.

20 At step 120, processor 67 increments parameter I ($I = 3$). At step 130, processor 67 tests whether $I = S$. Since I is less than S, processor 67 proceeds to step 140 and tests whether $I = 1$. Since $I = 3$ in this iteration, processor 67 proceeds to step 160.

At step 160, processor 67 subtracts the previously extracted signal(s) from
25 the composite signal ($A + B + C + D$). At this point, signals A and B have been extracted, so the result of the subtraction is an intermediate signal ($C + D$). Processor 67 then proceeds to step 170 and nulls J signals ($J = 4$ to 4), that is,

signal D, from the intermediate signal, as generally described above. What remains after nulling is signal C.

Processor 67 returns to step 120.

Extraction of signal D will now be described.

5 At step 120, processor 67 increments parameter I ($I = 4$). At step 130, processor 67 tests whether $I = S$. Since I is equal to S, processor 67 proceeds to step 180, and subtracts the previously extracted signals A, B, C from the composite signal ($A + B + C + D$) to extract signal D. Processor 67 then proceeds to step 190, and determines that all the transmitted signals have been extracted, so
10 processing is completed.

In other embodiments, each of k locations has n antennas. A set of m signals is transmitted such that each of the m signals is transmitted from at least two of the $k \cdot n$ antennas.

For redundancy, a situation in which $k = m = n$ is preferred.

15 Fig. 14 shows cell 14 having antennas around its perimeter at locations referred to as 0° , 120° and 240° . At each of these three locations, there are three antennas. Each of the three antennas at a location transmits one of three signals at a carrier frequency f_1 . In this configuration, even if the transmission from one of the locations is blocked, the receiver is still able to receive the desired signal from the
20 other two locations.

Specifically, location 0° of cell 14 has antennas 30, 31, 32, respectively transmitting signals A, B, C. Location 120° of cell 14 has antennas 33, 34, 35, respectively transmitting signals A, B, C. Location 240° of cell 14 has antennas 36, 37, 38, respectively transmitting signals A, B, C.

25 Fig. 15 shows this situation, namely, that at each of the three locations, the same set of three signals is transmitted, and each of the transmissions is at a carrier

frequency f_1 .

Fig. 16A shows a partial redundancy situation in which there are four locations 0° , 90° , 180° , 270° ($k = 4$) each having two antennas ($n = 2$) transmitting three signals A, B, C ($m = 3$). It will be seen that signals A and C are transmitted from each of three antennas, while signal B is transmitted from only two antennas.

Fig. 16B is similar to Fig. 16A, except that the four locations are at 0° , 120° , 240° and center (the first three locations are equidistantly spaced around the perimeter of the cell, while the fourth location is at the center of the cell).

Figs. 17-19 illustrate different signal distribution techniques for the set of signals transmitted from each antenna location.

Fig. 17 shows transmitters 90, 91, 92 respectively applying signals A, B, C to cables which are coupled to base station antenna locations 0° , 120° , 240° of cell 9. Wireless microwave links may be used instead of cable. Receivers 80, 81, 82 are co-located with transmitters 90-92. Each of receivers 80-82 receives a composite of all the signals transmitted by all of the mobile units in cell 9, and functions in similar manner as receiver circuits 64-66 to deliver respective composite signals differing in phase to processor 84, which operates in similar manner as processor 67 to extract a signal for each of the transmitting mobile units in cell 9. Transmitters 90-92, receivers 80-82 and processor 84 are located at a mobile switching center (MSC) (not shown) which serves cell 9.

Fig. 18 shows transmitters 90, 91, 92 respectively applying signals A, B, C to cables which are coupled to base station antenna locations 0° , 120° , 240° of cell 15 in daisy chain fashion. Transmitters 90-92 are located at a mobile switching center (MSC) (not shown) which serves cell 15.

Fig. 19 shows receivers 70-78 respectively receiving signals from each of

the antennas in cell 15. Each of receivers 70-78 receives a composite of all the signals transmitted by all of the mobile units in cell 15, and functions in similar manner as receiver circuits 64-66 to deliver respective composite signals differing in phase to processor 79, which operates in similar manner as processor 67 to extract a
5 signal for each of the transmitting mobile units in cell 15.

Instead of arranging the transmission as shown in Fig. 18, transmitters 90-92 may be configured as shown in Fig. 19. Transmitters 90-92, receivers 70-78 and processor 79 are located at a mobile switching center (MSC) (not shown) which serves cell 15.

10 Addition of antennas to increase capacity can be done in several ways, and may include addition of microcells to an existing cell plan.

Fig. 20 shows a layout of hexagonal cells. Cell 200 is shown as having antennas located at 0° , 120° and 240° , referenced as positions 201, 202, 203, respectively, as for cells 13 and 14 discussed above. The other cells in Fig. 20
15 similarly have antennas located at 0° , 120° and 240° . Let it be assumed that each location has a set of three antennas, unless otherwise specified. Cell 10 in Fig. 1 has one antenna at one position, whereas cell 200 in Fig. 20 has nine antennas at three positions. Relative to the capacity of cell 10 in Fig. 1, cell 200 in Fig. 20 has three times the capacity, since three separate signals are transmitted on the same
20 carrier frequency from each of the antennas in the set of antennas located at each of positions 201-203.

Adding antennas at the unused vertices of each hexagonal cell is illustrated in cells 210, 220, 230, 240 of Fig. 20. Before the addition, a set of three antennas for each cell was at positions 211, 212, 213, 221, 222, 223, 231, 232, 233, 241,
25 242, 243. As a consequence of the addition, a set of three additional antenna per cell is added at positions 211-243, and a set of six antennas for each cell is added at positions 214, 215, 216, 224, 225, 226, 234, 235, 236, 244, 245, 246. Thus, each

of cells 210-240 has six antennas at each of six positions. Cell 210 has 36 antennas located at six positions. Relative to the capacity of cell 10, cell 210 has six times the capacity, since six separate signals are transmitted on the same carrier frequency from each of the antennas in the set of antennas located at each of positions 211-
5 216.

Adding antennas at the center and at the unused vertices of each hexagonal cell, and then splitting the original hexagonal cell into six triangular microcells having 60° sectors rather than 120° sectors is illustrated in microcells 250A-250F, 260A-260F, 270A-270F, 280A-280F of Fig. 20. Each of microcells 250A-280F
10 has three antennas at each of three positions. Each of microcells 250A-250F has nine antennas, and there are six microcells in the group, thus, the area formerly occupied by cell 250 has 54 antennas at seven positions (the six vertex positions have two sets of three antennas, while the center position has six sets of three
15 antennas). In fact, the vertex positions also have a total of six sets of three antennas, but each microcell sharing the vertex is served by only two sets of the six sets. Relative to the capacity of cell 10, the group of microcells 250A-250F has eighteen times the capacity, since in each microcell, three separate signals are transmitted on the same carrier frequency from each of the antennas in the set of three antennas located at vertex of a triangular microcell, and there are six
20 microcells in the group, thus eighteen signals are transmitted in the area formerly occupied by cell 250.

Fig. 21 shows a plan of hexagonal cells (solid lines). Cell splitting which results in four hexagonal microcells (dashed lines) occupying the area of one cell is also depicted in Fig. 19. Other ways of configuring microcells will be apparent to
25 one of ordinary skill in the art.

The microcells in the upper right region of Fig. 21 each have antennas at positions 0° , 120° , 240° . More specifically, the cells have antennas at positions

311, 312, 313, 321, 322, 323, 331, 332, 333, 341, 342, 343, 351, 352, 353, 361, 362, 363, 361, 362, 363, while the microcells have antennas at the aforementioned positions and at positions 314, 315, 316, 324, 325, 326, 334, 335, 336, 344, 345, 346, 354, 355, 356, 364, 365, 366, 374, 375, 376. The number of antennas at each
 5 position in a microcell is the same as the number of antennas at each position in a cell. Whereas a cell uses nine antennas, the four microcells occupying the region of a cell use 36 antennas. The capacity of a region occupied by microcells as described is four times the capacity of a region occupied by a cell.

An alternative antenna arrangement is shown in the lower left region of Fig.
 10 19. Here, a cell is not split into microcells. Instead, antennas are added at positions on the perimeter of the cell equidistantly spaced from the previous neighboring positions. For example, positions 411, 412, 413 are at 0° , 120° , 240° of a hexagonal cell. Next, antennas are added to the remaining vertices of the hexagonal cell, at positions 415, 418, 421. Finally, antennas are added at the
 15 midpoints of the segments forming the hexagon, at positions 414, 417, 419, 422, 420, 416. There are a total of twelve positions on the perimeter of the cell. The number of antennas at each position in the cell is increased to twelve, matching the number of positions. A cell in this configuration uses 144 antennas. The capacity of a cell with twelve positions, as described, is four times the capacity of a cell with
 20 three positions and three antennas at each position.

The arrangement in the upper right region of Fig. 21 is preferred over the arrangement in the lower left region of Fig. 21 because it uses fewer antennas (36 instead of 144), and because mobile receivers in the upper right region require only three antennas, rather than twelve. Minimizing the number of antennas per mobile
 25 unit is an important consideration.

Figs. 22-24 illustrate rectilinear cells. Although the cells of Fig. 22 are depicted as square, it will be appreciated that they could be rectangular, when, for

example, antennas are positioned at street corners in a city laid out in rectangular form, such as mid-town Manhattan, New York, which has relatively long blocks in the east-west direction and relatively short blocks in the north-south direction, as shown in Figs. 23-24.

5 Cell 500 of Fig. 22 is shown as having antennas located at positions 501, 502, 503, 504. Antennas 501-504 are directional antennas having a 90° beamwidth. Let it be assumed that there are four antennas at each position. Cell 500 includes 16 antennas. The capacity of cell 500 is four times the capacity of a cell of the same size having one antenna at its center.

10 Cells 510, 520, 530, 540 illustrate addition of antennas at positions around the perimeter of the cell, equidistantly spaced between the previous neighboring antennas. That is, capacity is added by placing antennas at locations 515-518, 525-528, 535-538 and 545-548. There are eight positions in each cell, so eight antennas should be located at each position. Cell 510, for example, includes 64 antennas.
15 The capacity of cell 510 is twice the capacity of cell 500.

Alternatively, in addition to adding antennas to positions on the perimeter of a cell, antennas can also be added at the center of the cell, and the cell split into microcells. The groups of microcells 550A-550D, 560A-560D, 570A-570D, 580A-580D, each occupy the area of one cell. Microcells 550A-550D each have 16
20 antennas, so this group of microcells has 64 antennas. The capacity of microcells 550A-550D is four times the capacity of cell 500. The arrangement in the lower left region of Fig. 22 is preferred over the arrangement in the upper right region of Fig. 22 because it uses fewer antennas.

Fig. 23 illustrates a city cell layout having cell sites at street corners. Fig.
25 24 illustrates a city cell layout having cell sites at the center of long blocks. Due to the presence of buildings on the blocks, communication performance differs in the cell layouts of Figs. 23 and 24.

Figs. 23 and 24 each show three original cells split into microcells. The microcells in Figs. 23 and 24 are identical in that each microcell has two vertices at street corners and two vertices at centers of blocks.

Although illustrative embodiments of the present invention, and various
5 modifications thereof, have been described in detail herein with reference to the accompanying drawings, it is to be understood that the invention is not limited to these precise embodiment and the described modifications, and that various changes and further modifications may be effected therein by one skilled in the art without departing from the scope or spirit of the invention as defined in the appended
10 claims.

CLAIMS

1. A cellular communication system, comprising:
a plurality of signal transmission sites located at k different positions in a cell
with $k \geq 2$,
5 a plurality of antennas located at the signal transmission sites, each antenna for
transmitting one of m signals at the same carrier frequency in the cell with $m \geq 2$, each
of the signals being transmitted from at least one of the k different positions, each of
the signals representing a data signal devoid of a spreading signal; and
a receiving unit located in the cell at a location other than at the plurality of
10 signal transmission sites and having:
at least two antennas for receiving the m signals transmitted at the same carrier
frequency, and
a converter for converting the received signals into an output signal.
2. The system of claim 1, wherein at least two of the signal transmission sites are
15 located around the perimeter of the cell.
3. The system of claim 1, wherein at least one of the k different positions has at
least two of the antennas located thereat.
4. The system of claim 3, wherein there are n antennas located at each of the k
different positions with $n = k$.
- 20 5. The system of claim 4, wherein $m = k$ and each of the n antennas at each of the
 k different positions is operative to transmit a respective one of the m signals.
6. The system of claim 1, wherein at least one of the antennas receives the signal
to be transmitted via a communication channel originating at one of the signal
transmission sites for another of the antennas, and further comprising signal sources
25 for providing each of the signals to one of the antennas transmitting the signals.

-17-

7. The system of claim 1, wherein at least one of the cells has microcells, each of the microcells having a plurality of microcell antennas located at different positions of the microcell, each of the microcell antennas for transmitting one of at least two signals at the same carrier frequency, each of the at least two signals being transmitted
5 from at least one of the different positions in the microcell.
8. The system of claim 1, wherein there are n antennas located at each of the k different positions with $n \geq 2$.
9. The system of claim 1, further comprising:
a mobile unit having at least two antennas for receiving the m signals
10 transmitted at the same carrier frequency and a converter for converting the received signals into an output signal.
10. The system of claim 9, wherein there are n antennas located at each of the k different positions with $n \geq 2$.
11. The system of claim 1, further comprising a plurality of receiving antennas
15 located at the signal transmission sites for receiving mobile signals transmitted from respective mobile antennas of a mobile unit at the same mobile carrier frequency, the plurality of receiving antennas operating simultaneously with the plurality of transmitting antennas located at the signal transmission sites.
12. The system of claim 11, wherein there are nr receiving antennas and nt
20 transmitting antennas located at each of the k different positions with $nr \geq 2$ and $nt \geq 2$.
13. The system of claim 1, wherein the data signal represents a voice communication or a digital data communication.

-18-

14. A cellular communication system, comprising:
at least two cell antennas in a cell for receiving at least two signals transmitted from at least two mobile antennas of a mobile unit at the same carrier frequency, each of the at least two signals representing a respective data signal devoid of a spreading
5 signal, each of the cell antennas for supplying the received signals as a respective composite signal, and
a processor for processing the composite signals from the cell antennas to extract a desired one of the transmitted signals.
15. The system of claim 14, wherein the processor is operative to beamform the
10 composite signals.
16. The system of claim 15, wherein the processor is operative to extract a transmitted signal by cancelling at least one previously extracted signal from the composite signals to produce remaining composite signals, and beamforming the remaining composite signals.
17. The system of claim 15, wherein the processor is operative to extract a last
15 transmitted signal by cancelling at least one previously extracted signal from the composite signals.
18. The system of claim 14, further comprising a set of receiver circuits coupled to each of the plurality of cell antennas, each of the receiver circuits for bandpass
20 filtering the respective composite signal supplied from the cell antenna coupled thereto.
19. The system of claim 14, wherein the data signal represents a voice communication or a digital data communication.
20. The system of claim 14, further comprising the mobile unit having at least two
25 mobile antennas for respectively transmitting the at least two signals.

-19-

21. A method for communicating m respectively different signals having the same carrier frequency in a cell of a cellular communication system, comprising the steps of:
- 5 providing the m respectively different signals having the same carrier frequency to a plurality of antennas located at k different positions in the cell, each of the signals representing a respective data signal devoid of a spreading signal;
- transmitting the signals respectively provided to the antennas; and
- receiving the transmitted signals at a receiving unit located in the cell at a location other than at the k different positions and having:
- 10 at least two antennas for receiving the transmitted signals, and
- a converter for converting the transmitted signals into an output signal.
22. The method of claim 21, wherein at least two of the antennas are located around the perimeter of the cell.
23. The method of claim 21, wherein at least one of the k different positions has at least two of the antennas located thereat.
- 15 24. The method of claim 23, wherein there are n antennas located at each of the k different positions with $n = k$.
25. The method of claim 24, wherein $m = k$ and each of the n antennas at each of the k different positions is operative to transmit a respective one of the m signals.
- 20 26. The method of claim 21, further comprising signal sources for providing each of the signals to the antennas transmitting the signals in a serial sequence.
27. The method of claim 21, wherein at least one of the cells has microcells, each of the microcells having a plurality of microcell antennas located at different positions of the microcell, each of the microcell antennas for transmitting one of at least two

-20-

signals at the same carrier frequency, each of the at least two signals being transmitted from at least one of the different positions in the microcell.

28. The method of claim 21, wherein there are n antennas located at each of the k different positions with $n \geq 2$.

5 29. A method for communicating m respectively different signals having the same carrier frequency in a cell of a cellular communication system, comprising the steps of:

transmitting the m respectively different signals from m mobile antennas of a mobile unit at a transmitting location;

10 receiving the m signals transmitted for the mobile unit at different cell antennas, each of the signals representing a respective data signal devoid of a spreading signal, each of the cell antennas located at other than the transmitting location,

supplying the signals received by each of the different cell antennas as
15 respective composite signals, and

processing the composite signals from the cell antennas to extract a desired one of the transmitted signals.

30. The method of claim 29, wherein the step of processing includes beamforming the composite signals.

20 31. The method of claim 30, wherein the step of processing includes extracting a transmitted signal by cancelling at least one previously extracted signal from the composite signals to produce remaining composite signals, and beamforming the remaining composite signals.

-21-

32. The method of claim 30, wherein the step of processing also includes extracting a last transmitted signal by cancelling at least one previously extracted signal from the composite signals.
33. The method of claim 30, further comprising the step of bandpass filtering the signals received by each of the different cell antennas to form the respective composite signals.
34. A method for cellular communication, comprising the steps of:
transmitting m respectively different signals having the same carrier frequency in a cell of a cellular communication system from a plurality of transmitting antennas located at k different positions in the cell, each of the signals representing a data signal devoid of a spreading signal, a least one of the k positions having at least two transmitting antennas,
receiving the m signals transmitted at the same carrier frequency at a mobile unit having at least two antennas, and
converting the received signals into an output signal.
35. The method of claim 34, wherein there are n transmitting antennas located at each of the k different positions with $n \geq 2$.
36. A method for cellular communication, comprising the steps of:
transmitting m respectively different signals having the same carrier frequency in a cell of a cellular communication system from at least two transmitting antennas located at a mobile unit in the cell, each of the signals representing a data signal devoid of a spreading signal,
receiving, at a plurality of receiving antennas located at the k different positions in the cell, the transmitted signals, and
combining the transmitted signals to produce an output signal.

-22-

37. The system of claim 36, wherein there are nr receiving antennas and nt transmitting antennas located at each of the k different positions with $nr \geq 2$ and $nt \geq 2$.
38. A mobile cellular telephone, comprising:
5 at least two antennas for receiving at least two data signals transmitted at the same carrier frequency from different positions in a cell of a cellular communication system, each of the at least two data signals being devoid of a spreading signal,
a processor for combining the at least two received data signals to generate a processed signal, and
10 means for providing the processed signal to a user.
39. The cellular telephone of claim 38, wherein the processor is operative to beamform the at least two received signals.
40. The cellular telephone of claim 38, wherein each of the data signals represents a voice communication or a digital data communication.
- 15 41. A cellular communication system, comprising:
sources of k different sub-signals representing portions of a single data stream and being devoid of a spreading signal;
a plurality of signal transmission sites located at k different positions in a cell with $k \geq 2$, and
20 an antenna located at each of the signal transmission sites, each antenna for transmitting one of the k different sub-signals.
42. A cellular communication system, comprising:
a plurality of cell antennas in a cell for receiving at least two signals transmitted from respective transmitting antennas of a transmitting unit at the same
25 carrier frequency, each of the at least two signals representing a respective data signal

-23-

devoid of a spreading signal, each of the cell antennas for supplying the received signals as a respective composite signal, and

a processor for processing the composite signals from the cell antennas to extract a desired one of the transmitted signals.

5 43. A method for transmitting k respectively different sub-signals having the same carrier frequency in a cell of a cellular communication system, comprising the steps of:

providing the k different sub-signals representing portions of a single data stream and being devoid of a spreading signal to respective antennas located at a
10 plurality of signal transmission sites at k different positions in a cell with $k \geq 2$, and transmitting the different sub-signals from the antennas.

44. A method for receiving m respectively different signals having the same carrier frequency transmitted from m transmitting antennas of a transmitting unit in a cell of a cellular communication system, comprising the steps of:

15 receiving the m signals transmitted from the transmitting unit at different cell antennas, each of the signals representing a respective data signal devoid of a spreading signal,

supplying the signals received by each of the different cell antennas as respective composite signals, and

20 processing the composite signals from the cell antennas to extract a desired one of the transmitted signals.

45. A method for cellular communication, comprising the steps of:

transmitting m respectively different signals having the same carrier frequency in a cell of a cellular communication system from a plurality of transmitting antennas
25 located at k different positions in the cell, each of the signals representing a data signal devoid of a spreading signal, at least one of the k positions having at least two of the transmitting antennas,

-24-

receiving the m signals transmitted at the same carrier frequency at a receiving unit having at least two antennas, and
converting the received signals into an output signal.

46. A method for cellular communication, comprising the steps of:

5 transmitting m respectively different signals having the same carrier frequency in a cell of a cellular communication system from a plurality of transmitting antennas located at a transmitting unit in the cell, each of the signals representing a data signal devoid of a spreading signal,

10 receiving, at a plurality of receiving antennas located at the k different positions in the cell, the transmitted signals, and
combining the transmitted signals to produce an output signal.

47. A cellular telephone, comprising:

15 at least two antennas for receiving at least two data signals transmitted at the same carrier frequency from different positions in a cell of a cellular communication system, each of the at least two data signals being devoid of a spreading signal and representing portions of a data stream,

a processor for combining the at least two received data signals to generate the data stream, and

means for providing the data stream to a user.

FIG. 1
(PRIOR ART) 1/9

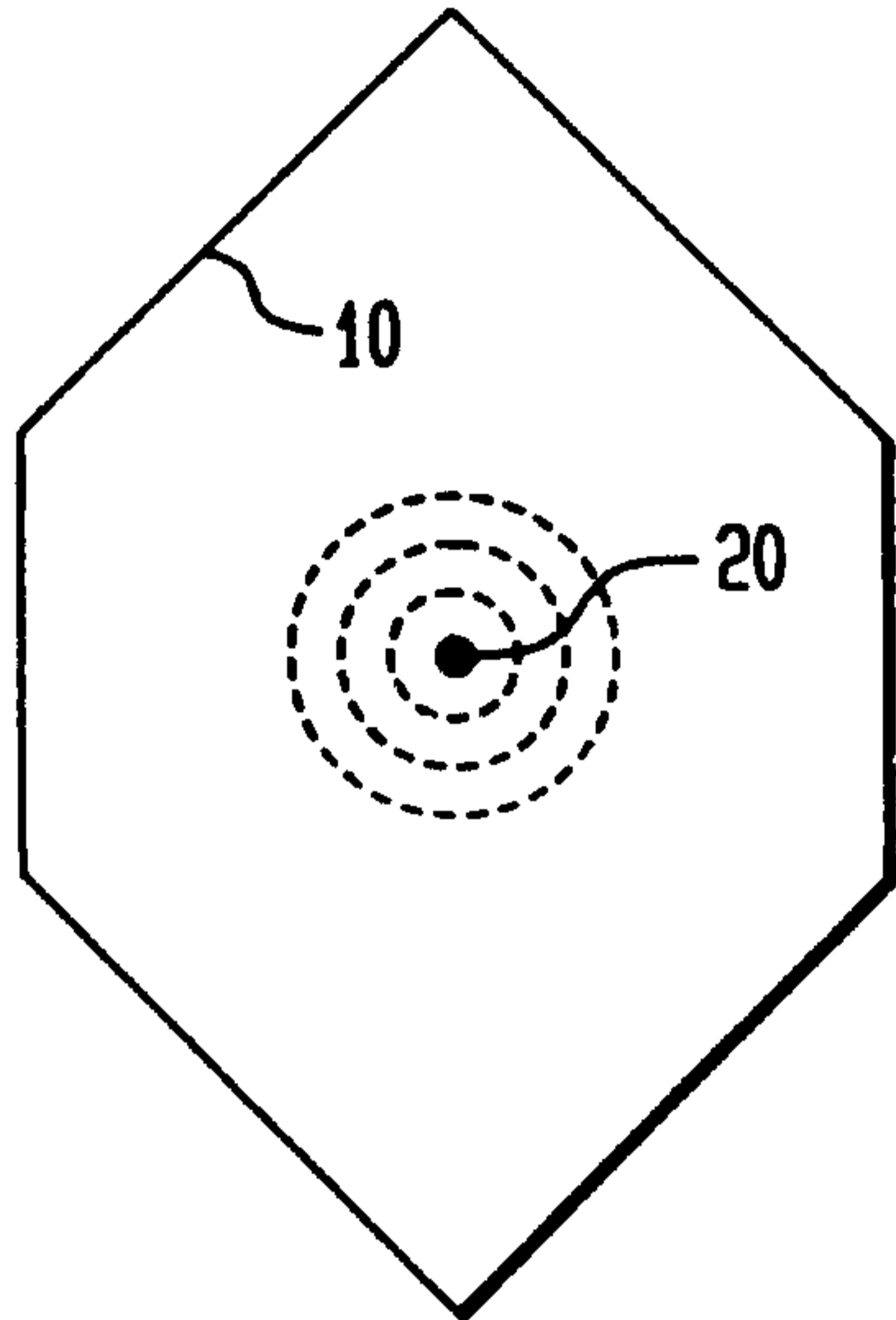

FIG. 2
(PRIOR ART)

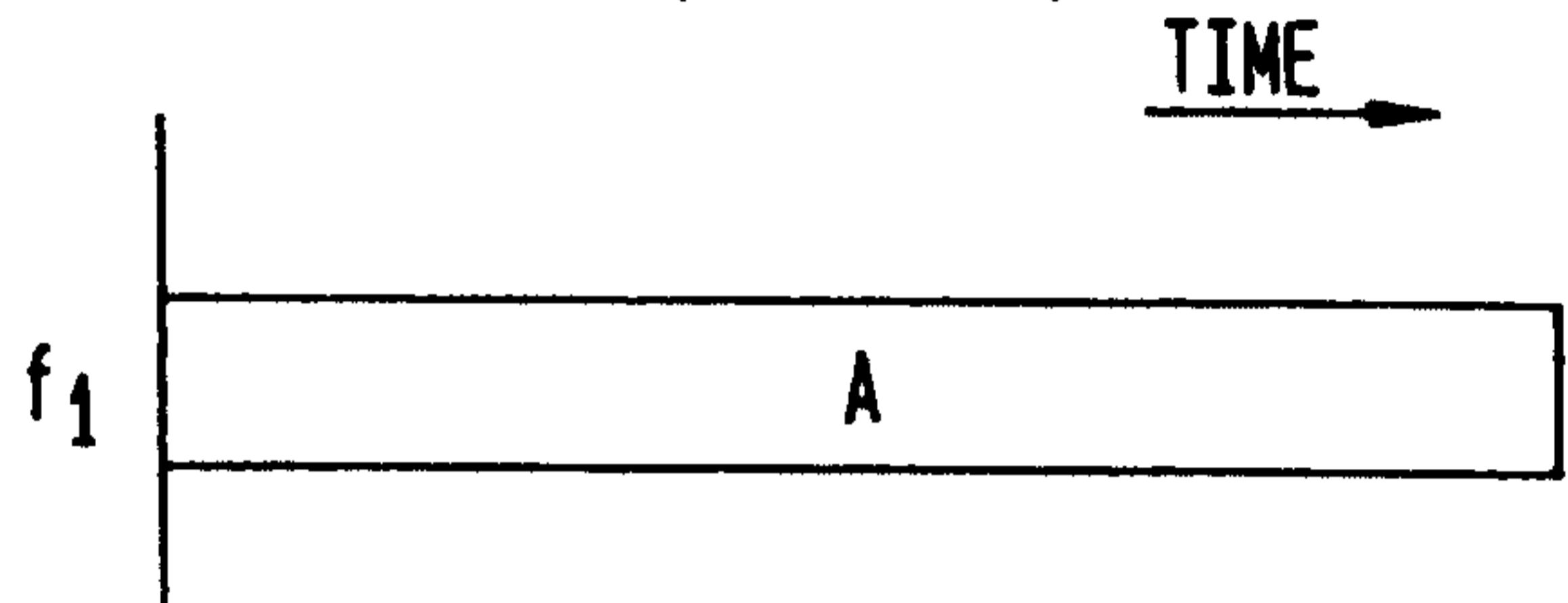

FIG. 3
(PRIOR ART)

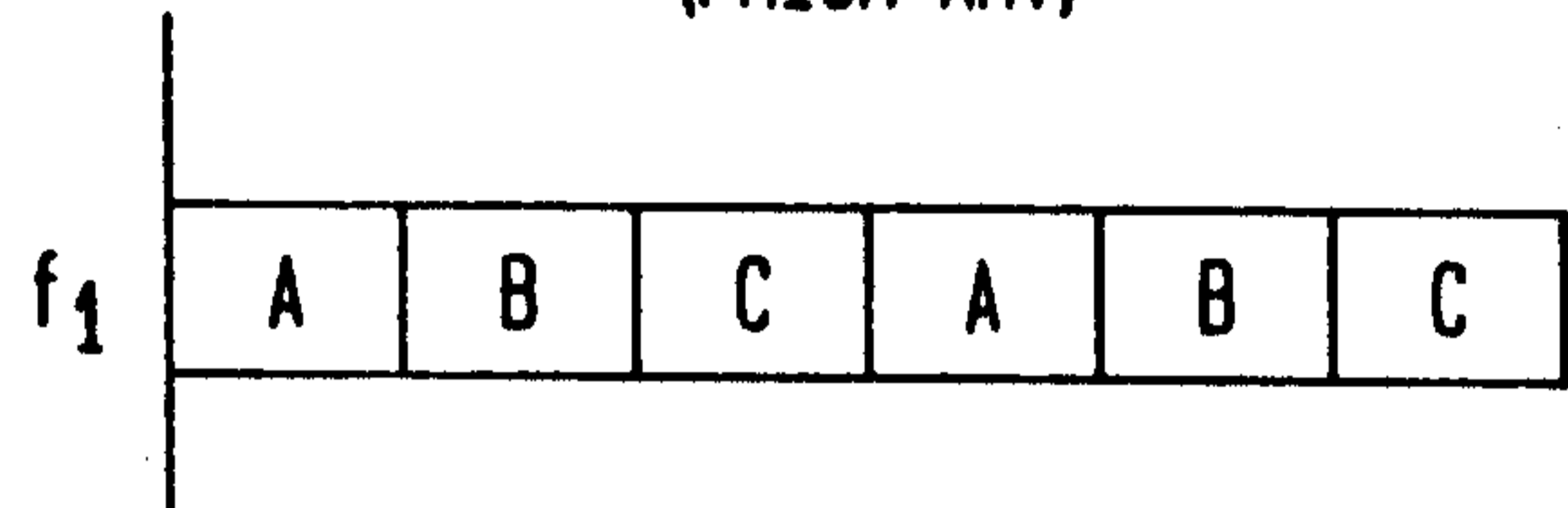

FIG. 4
(PRIOR ART)

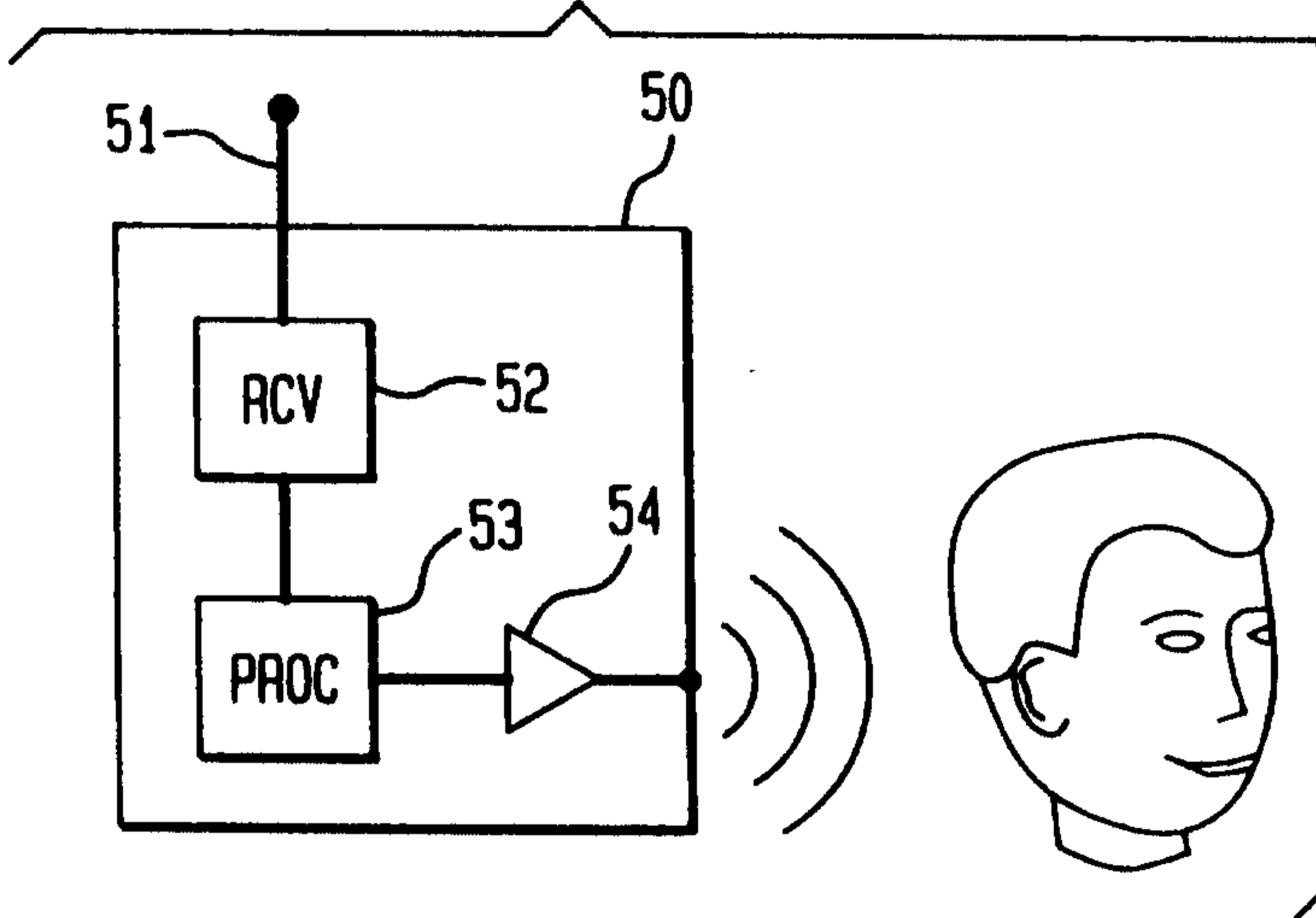

FIG. 5
(PRIOR ART)

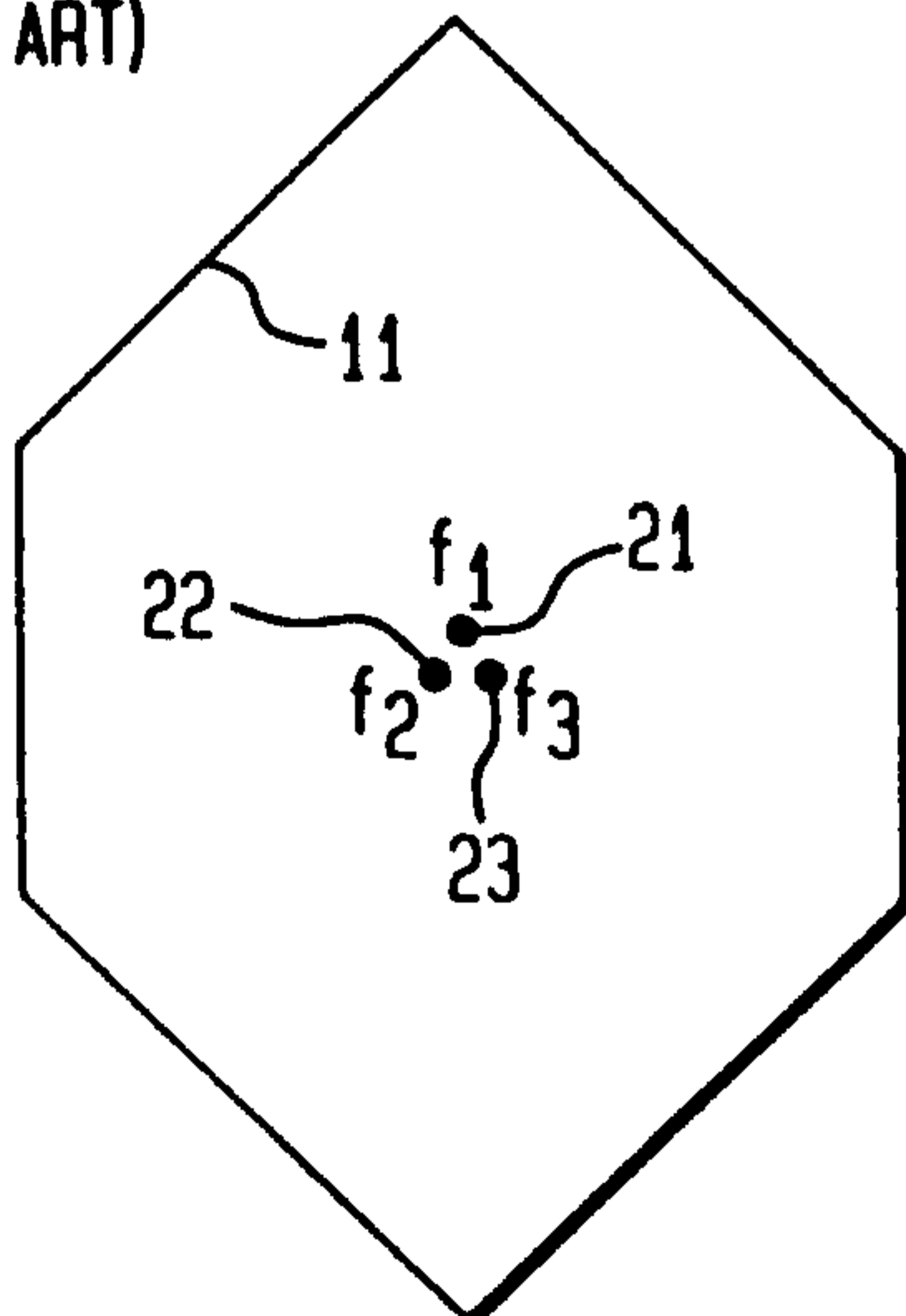

FIG. 6
(PRIOR ART)

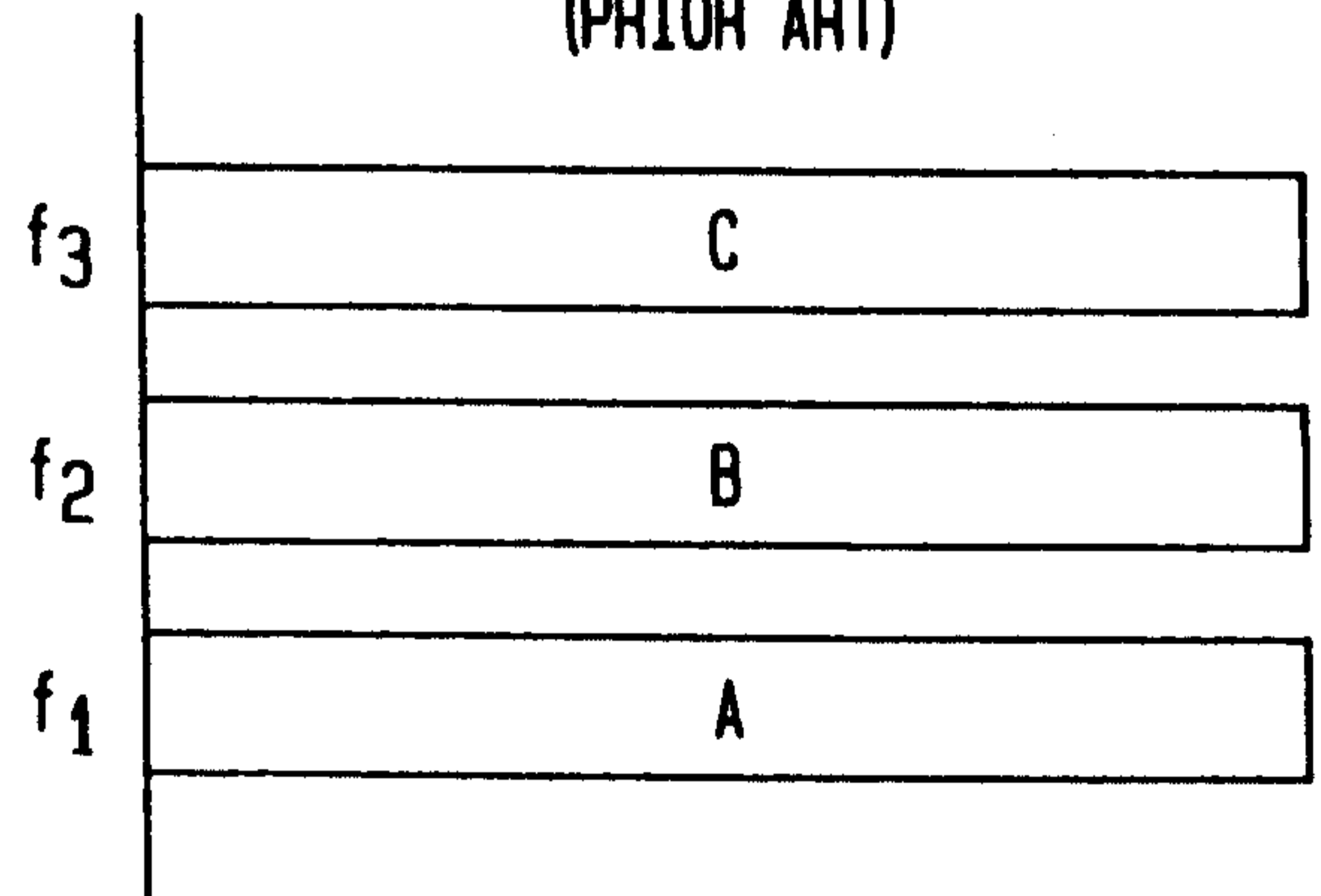

FIG. 7
(PRIOR ART)

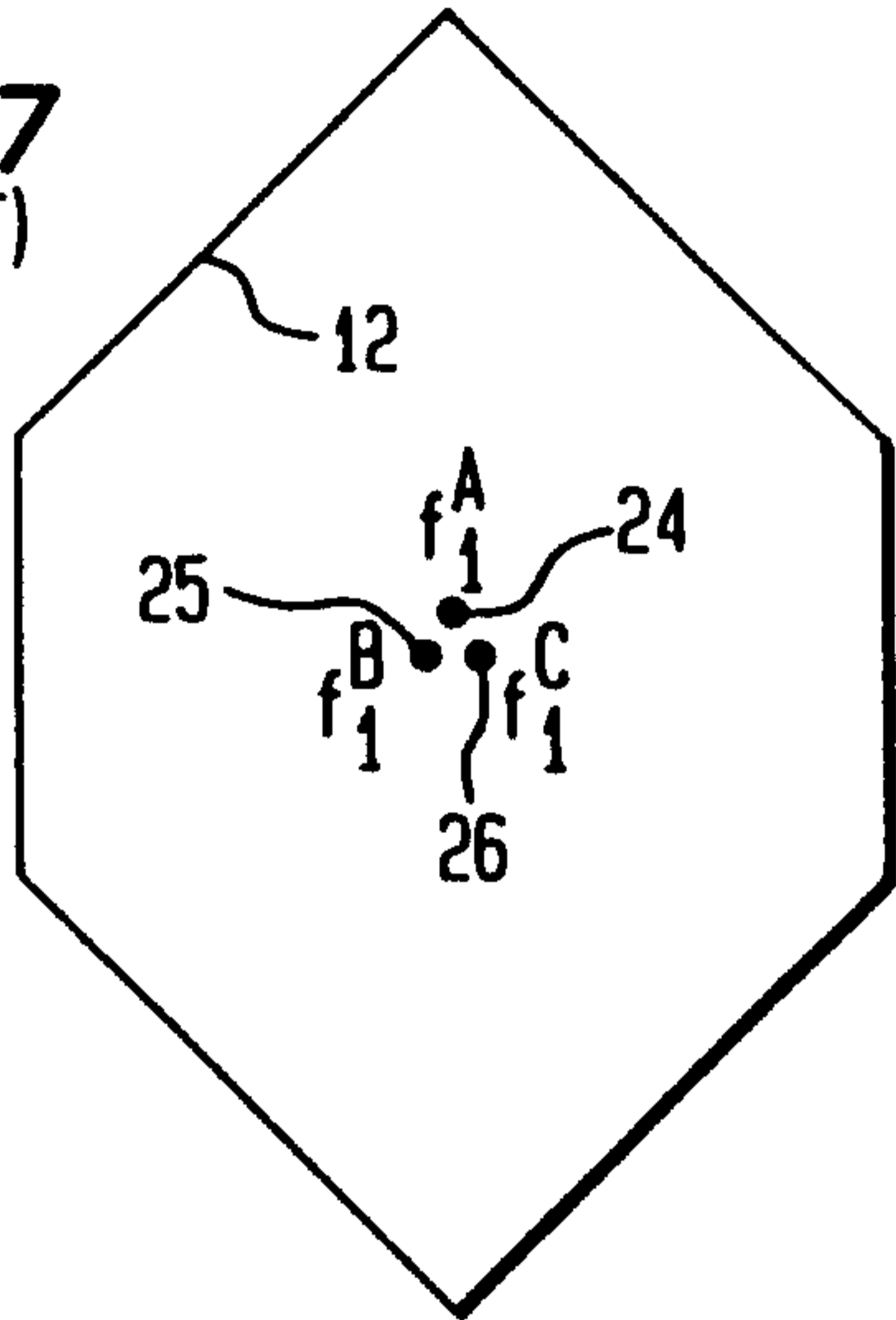

FIG. 8
(PRIOR ART)

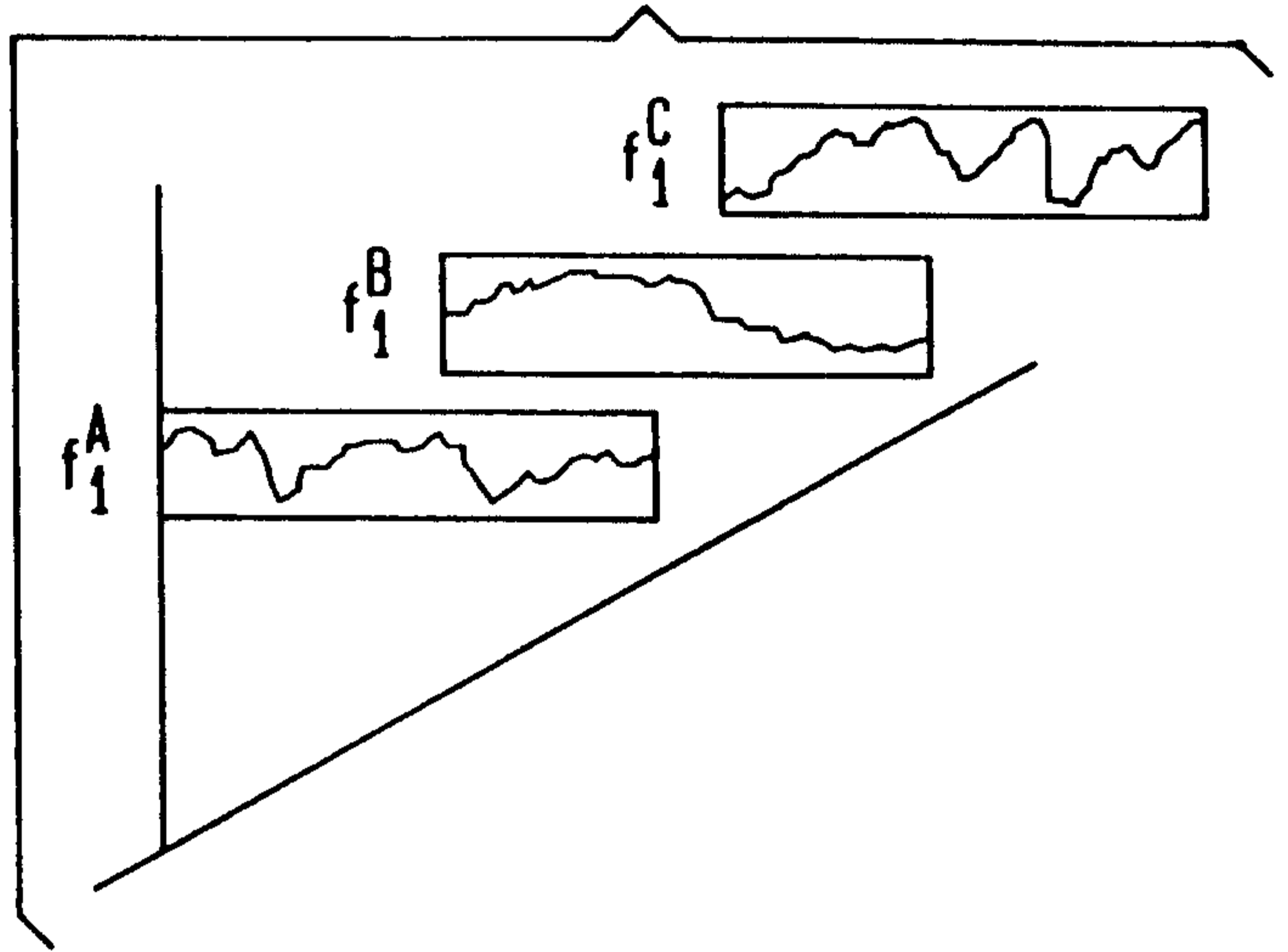

FIG. 9

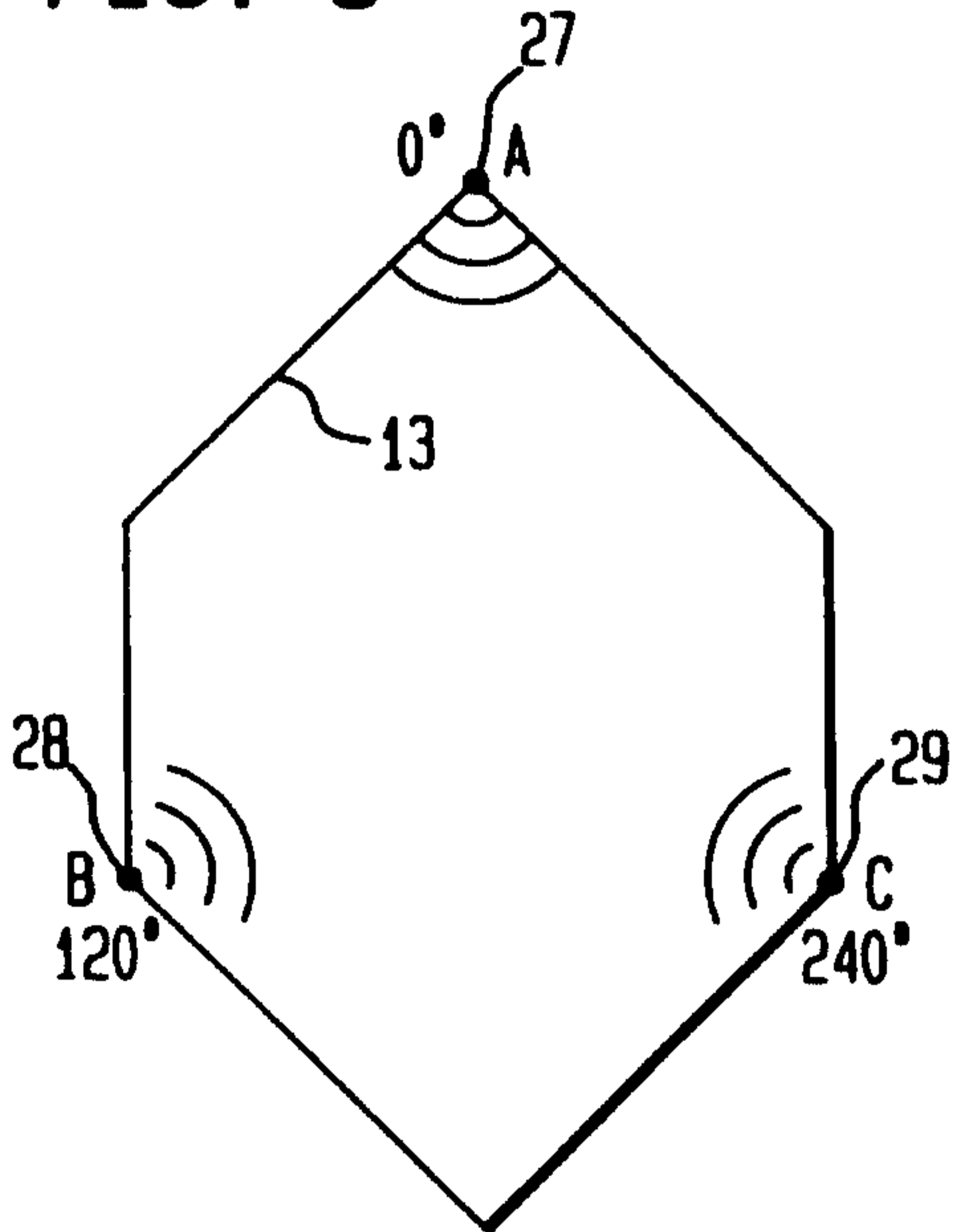

FIG. 10

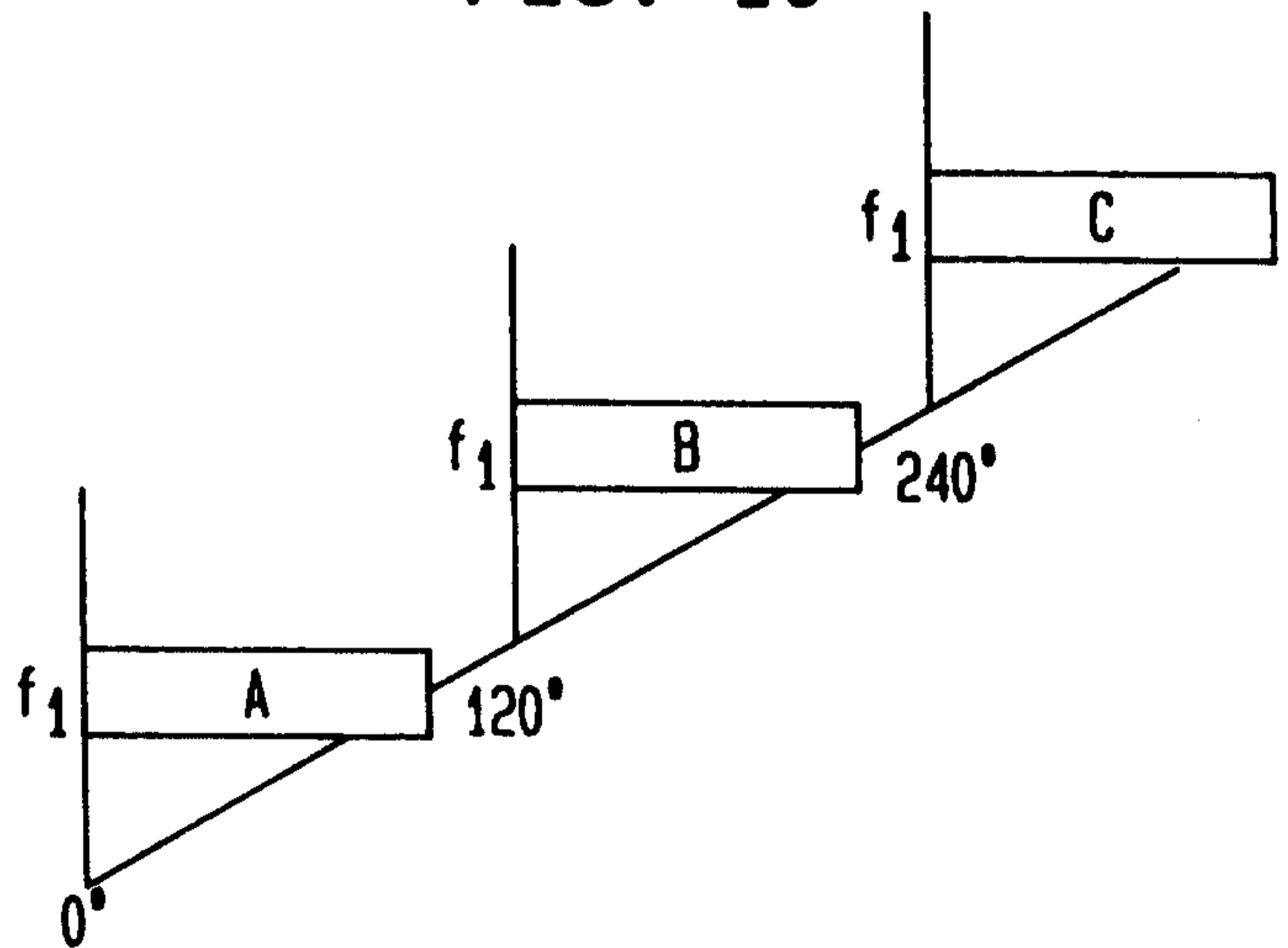
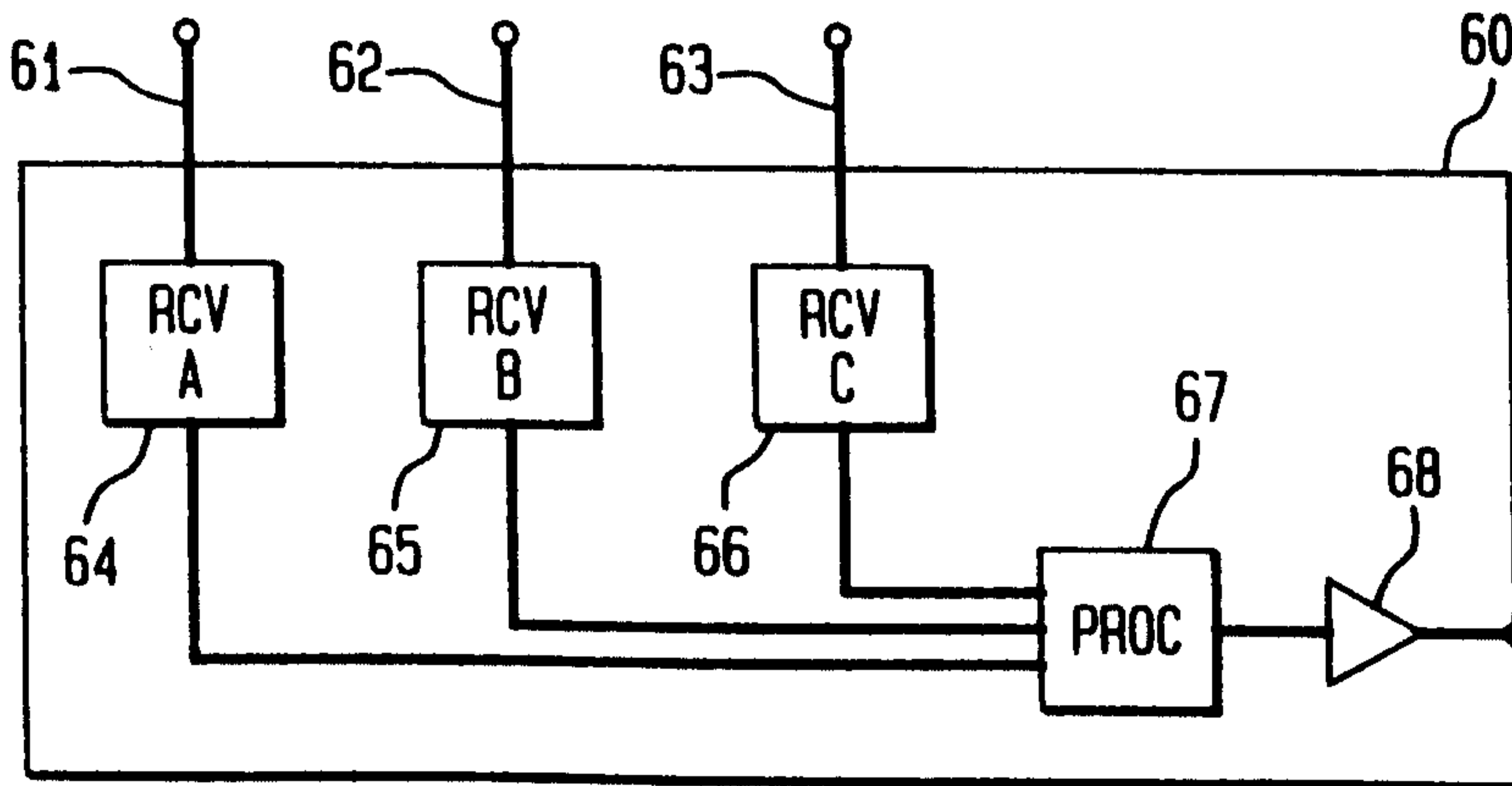

FIG. 11



3/9

FIG. 12

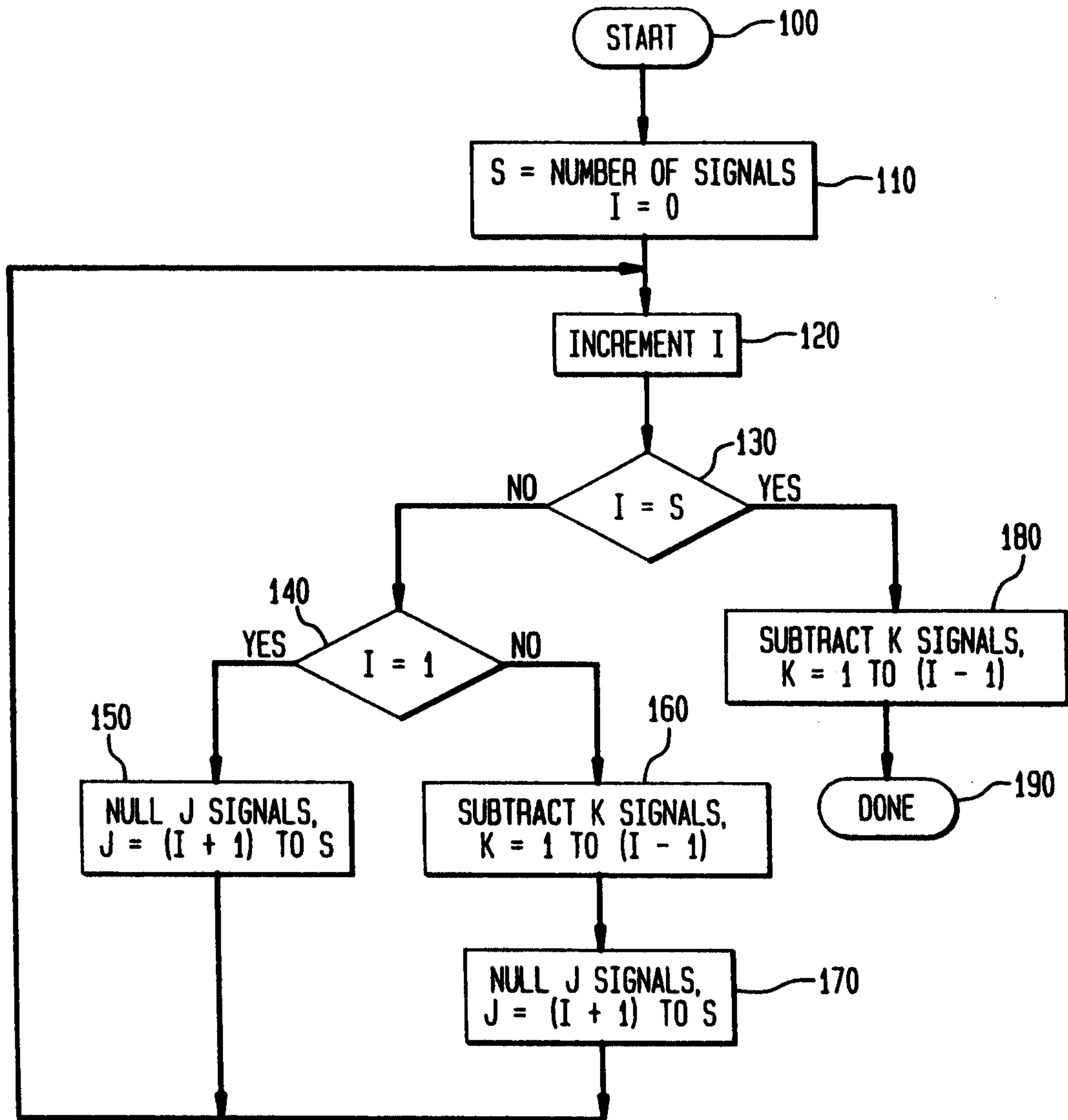
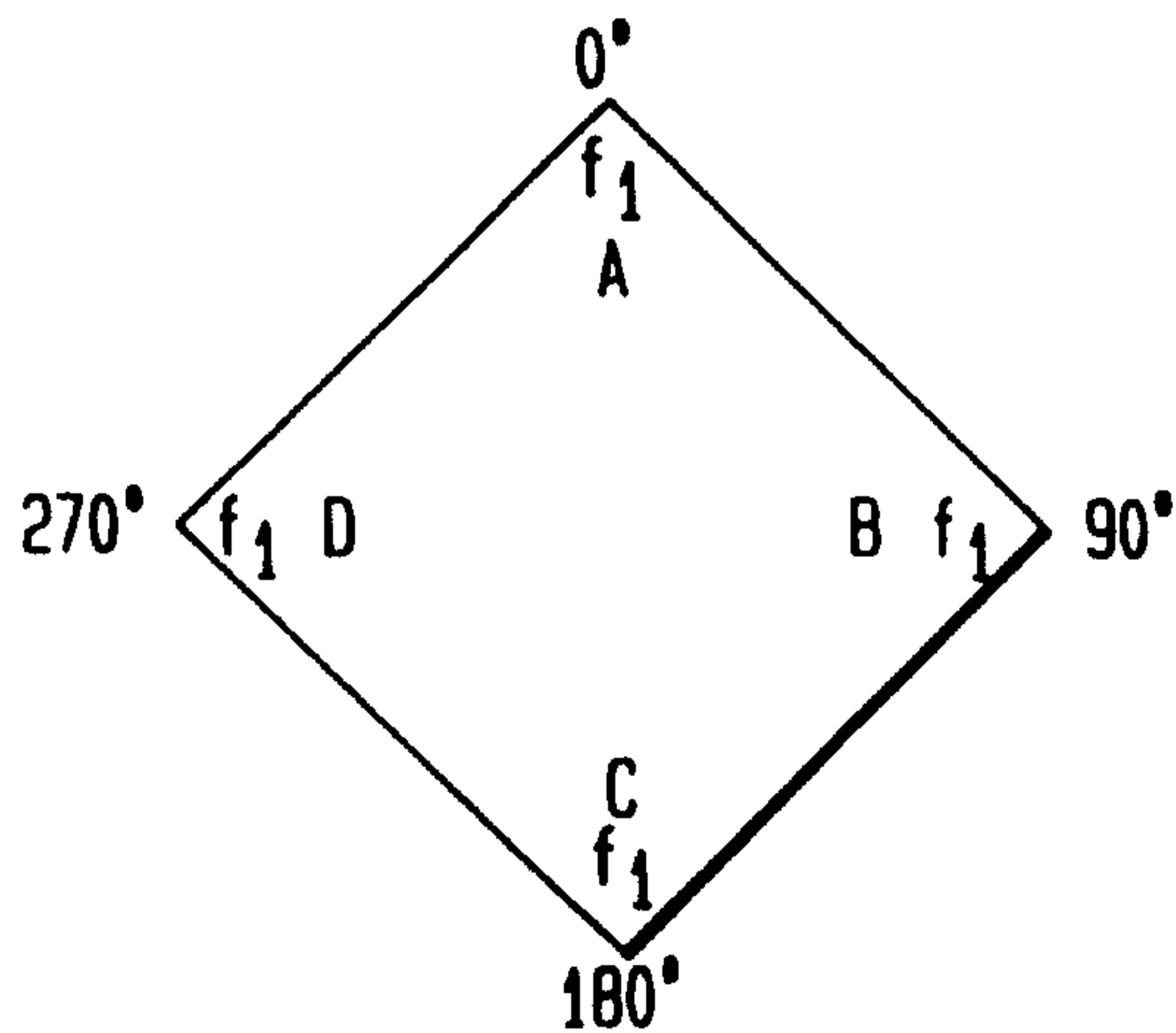
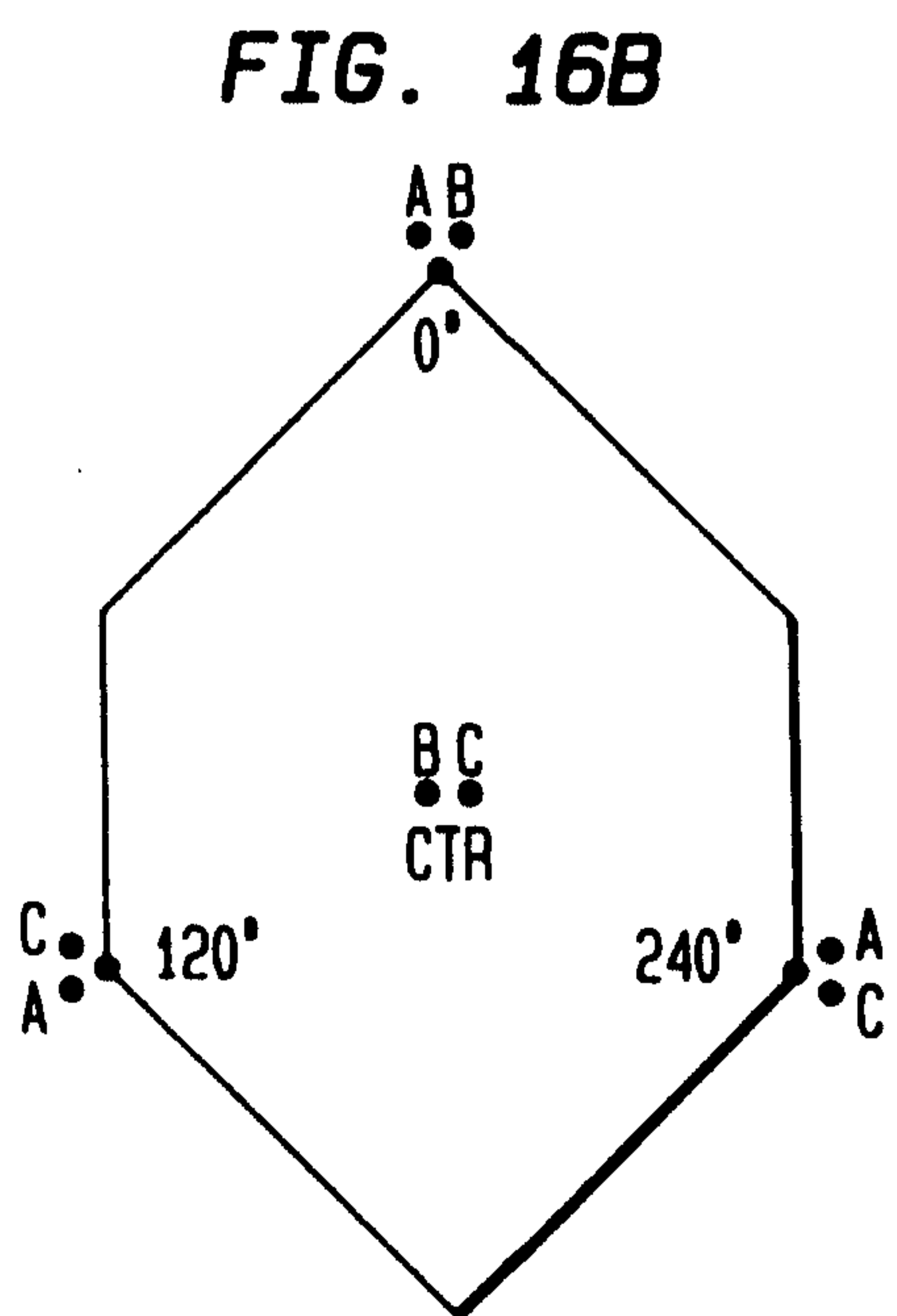
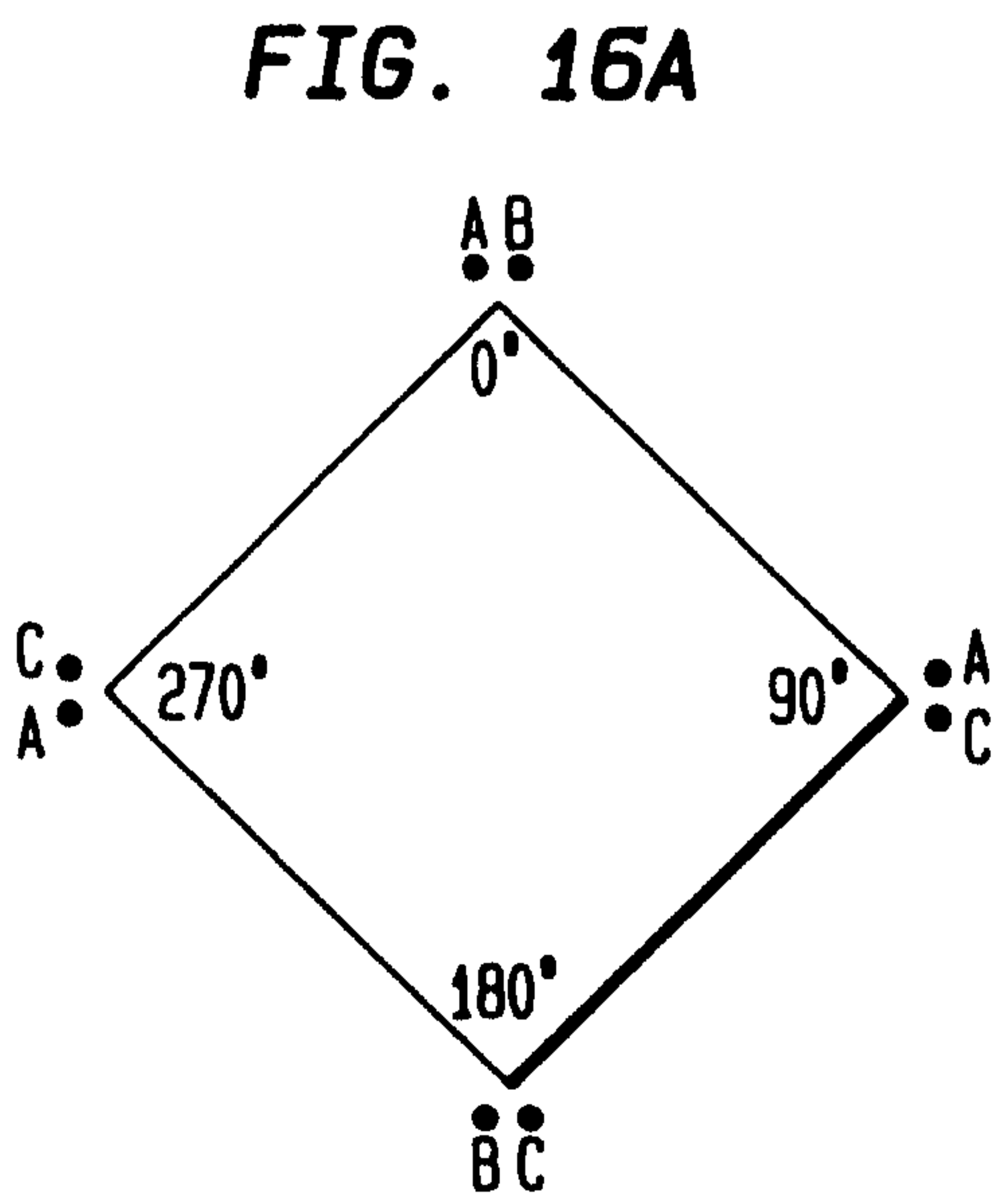
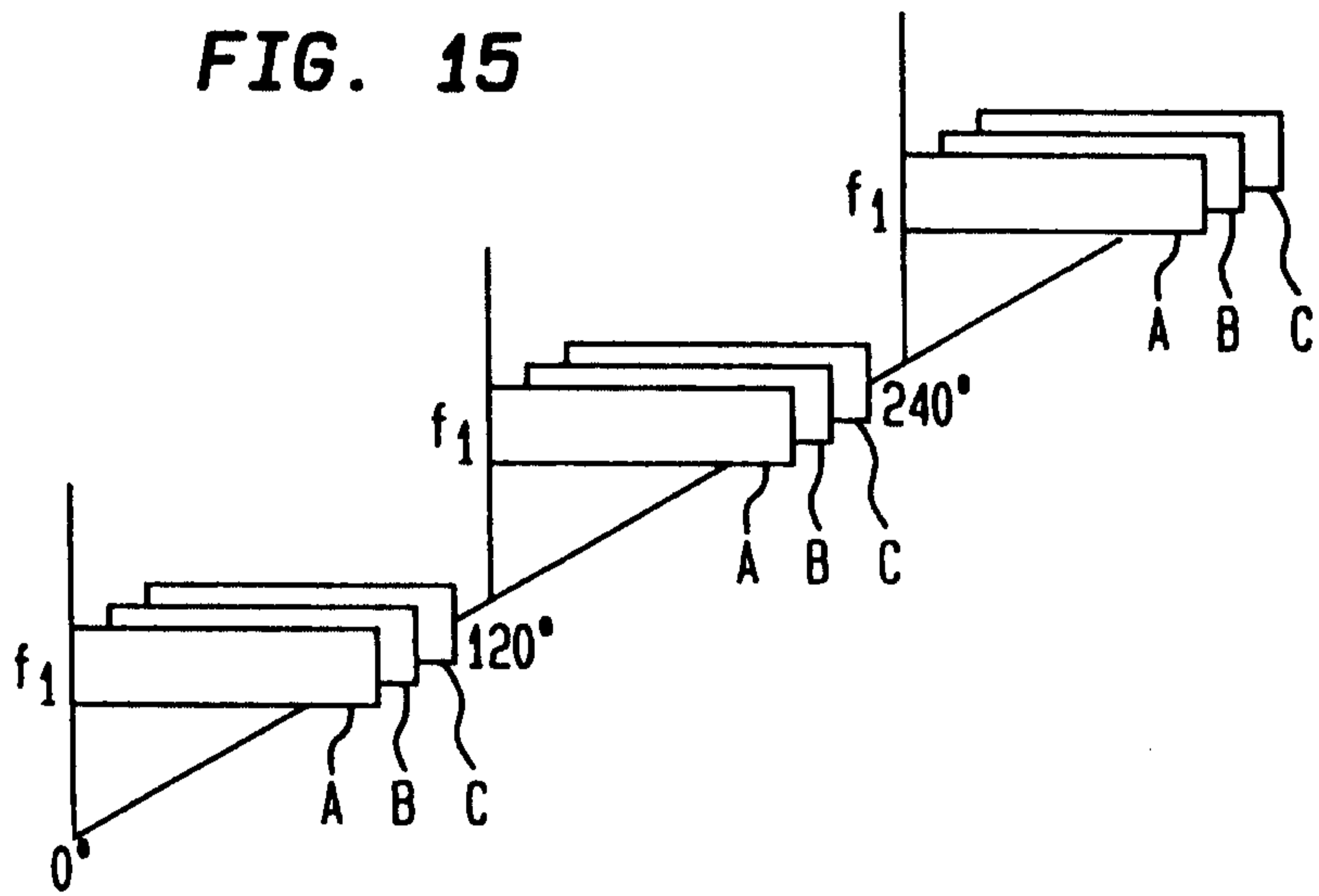
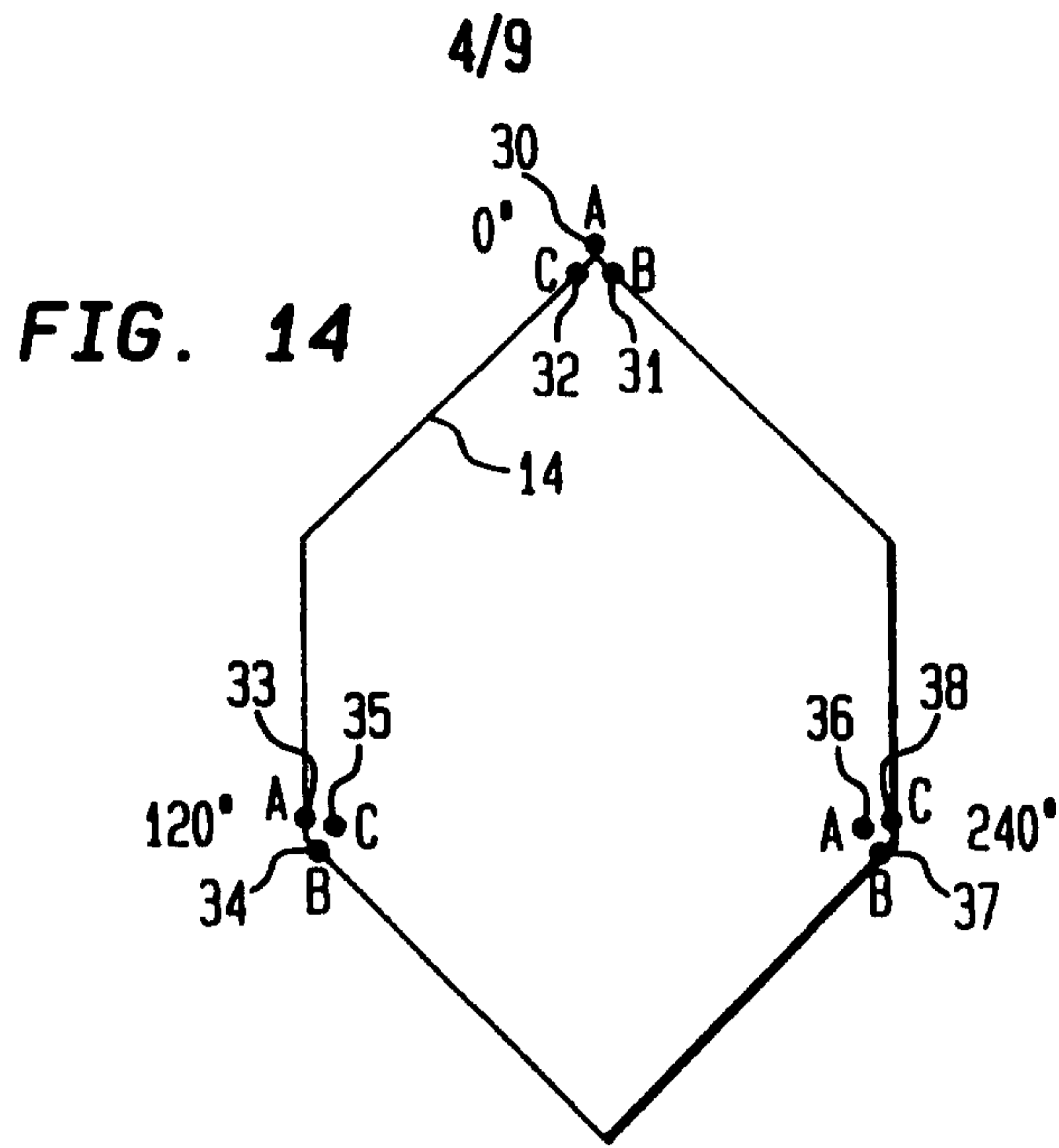

FIG. 13





5/9

FIG. 17

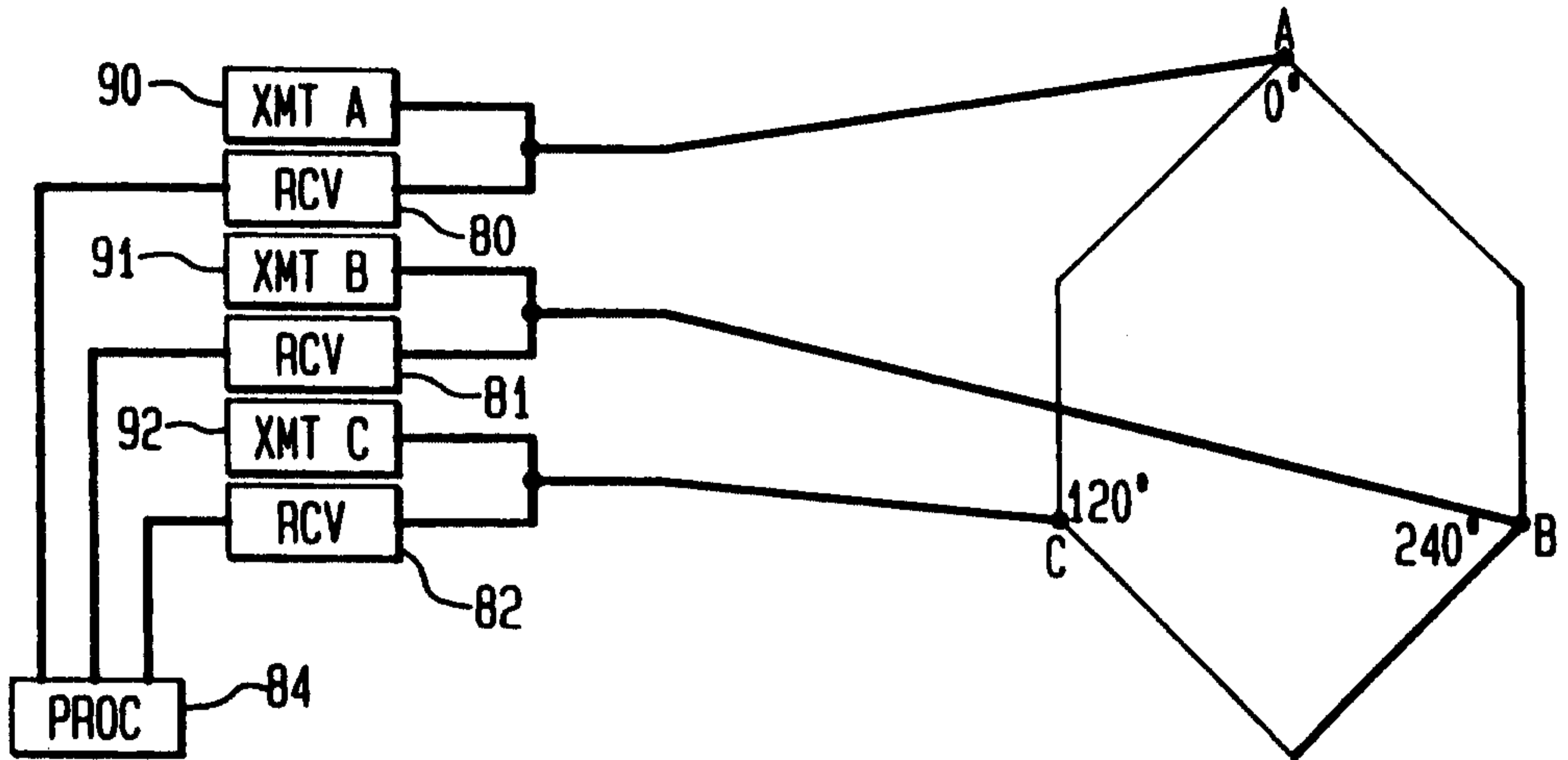

FIG. 18

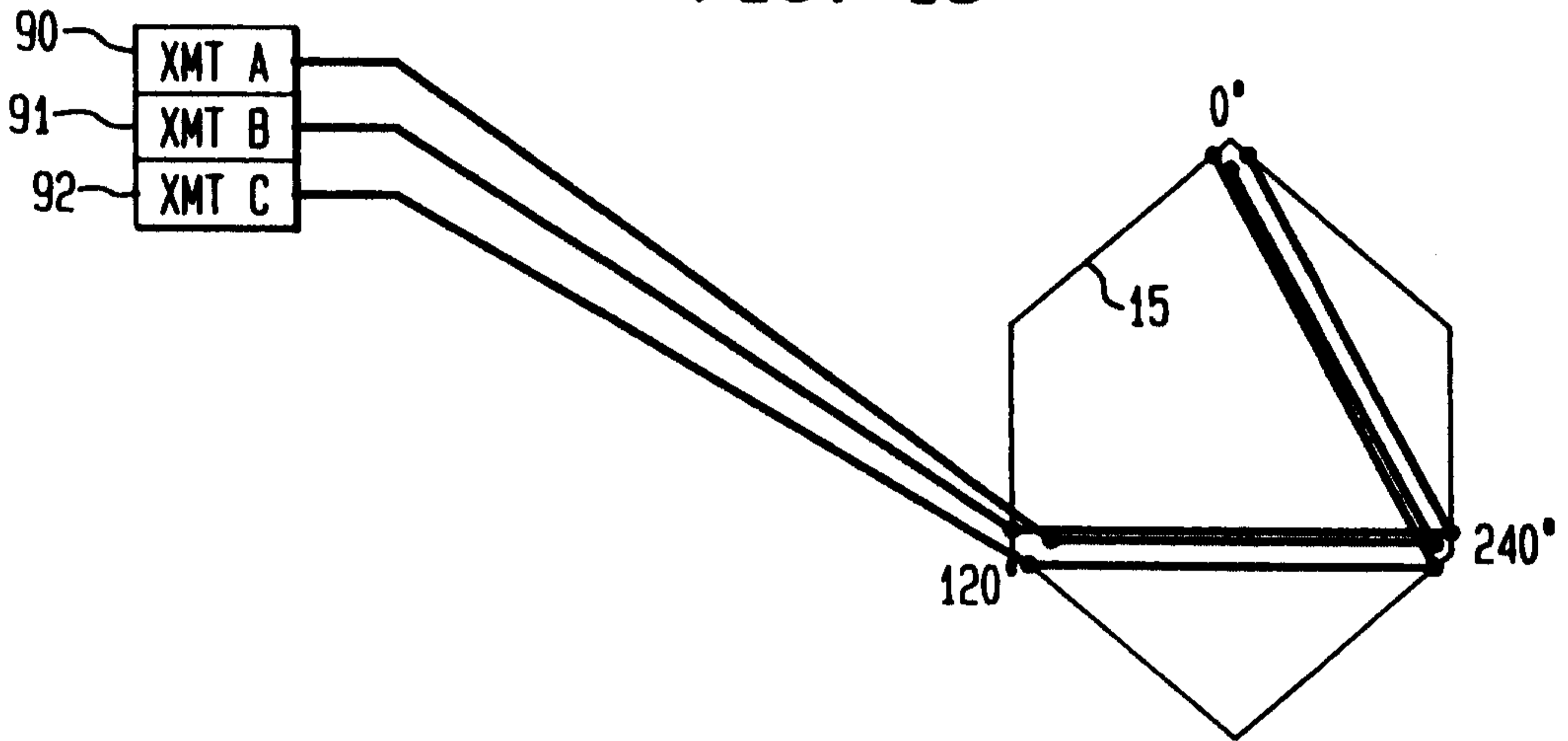

FIG. 19

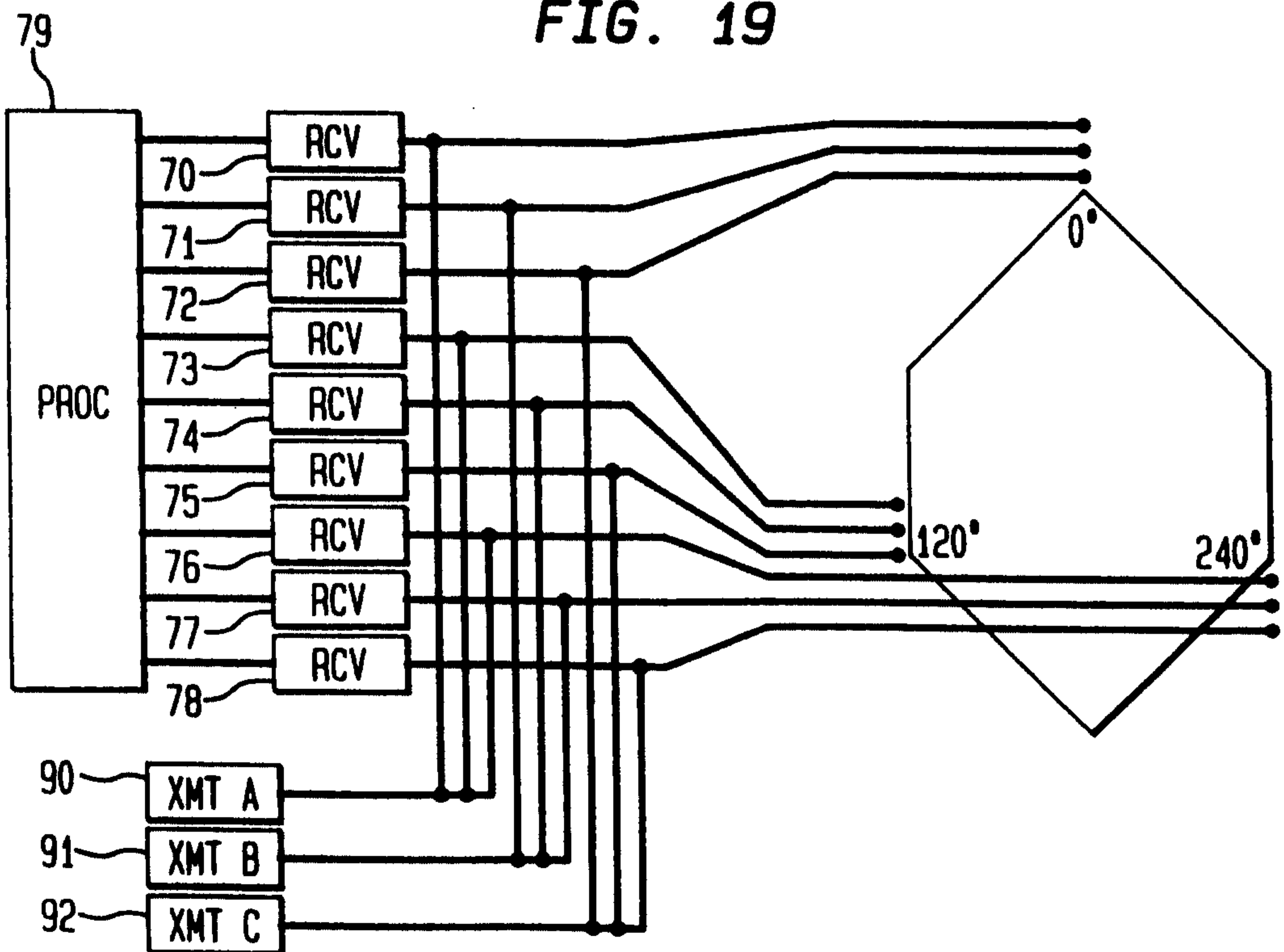

FIG. 20

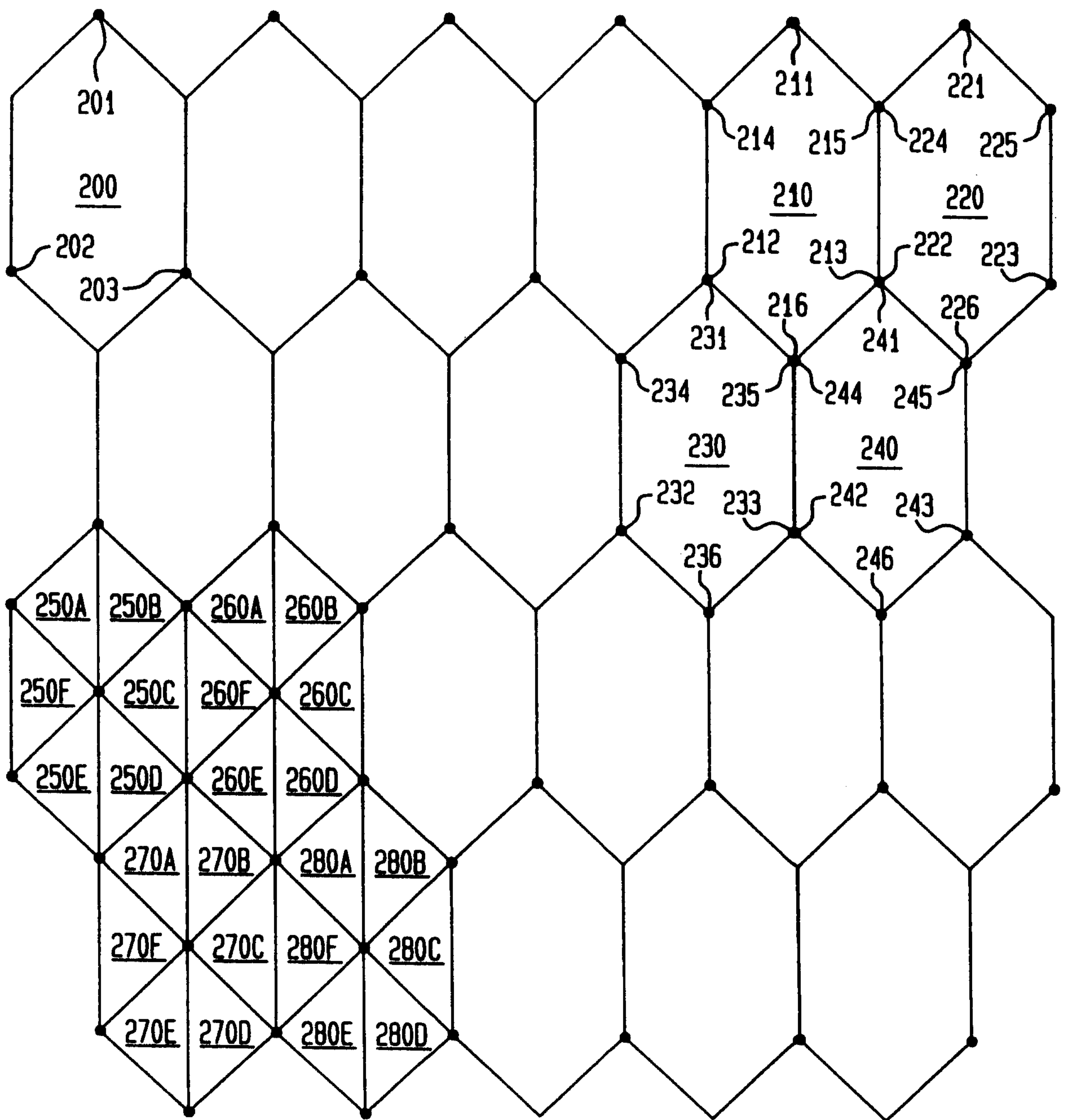

FIG. 21

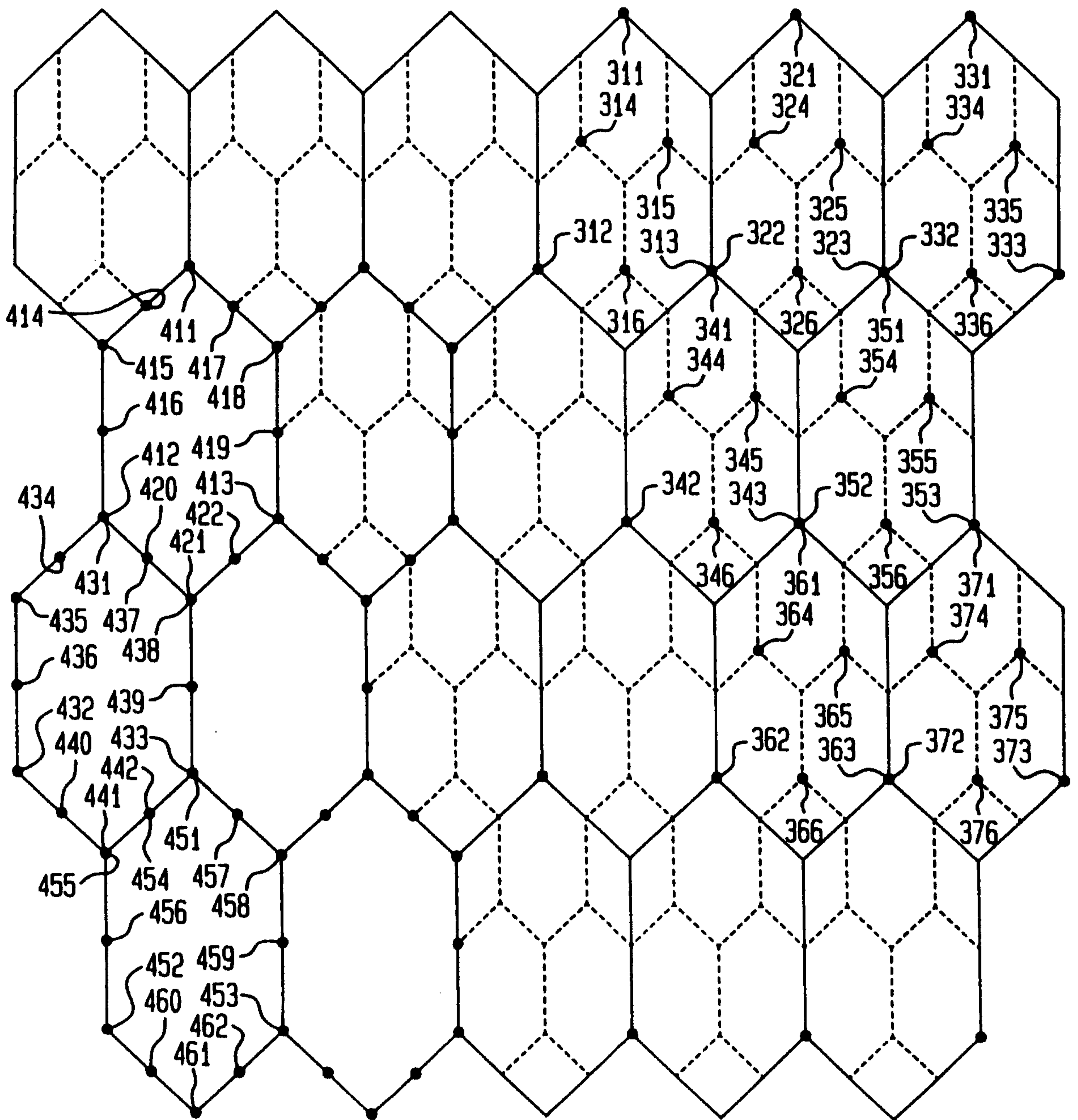
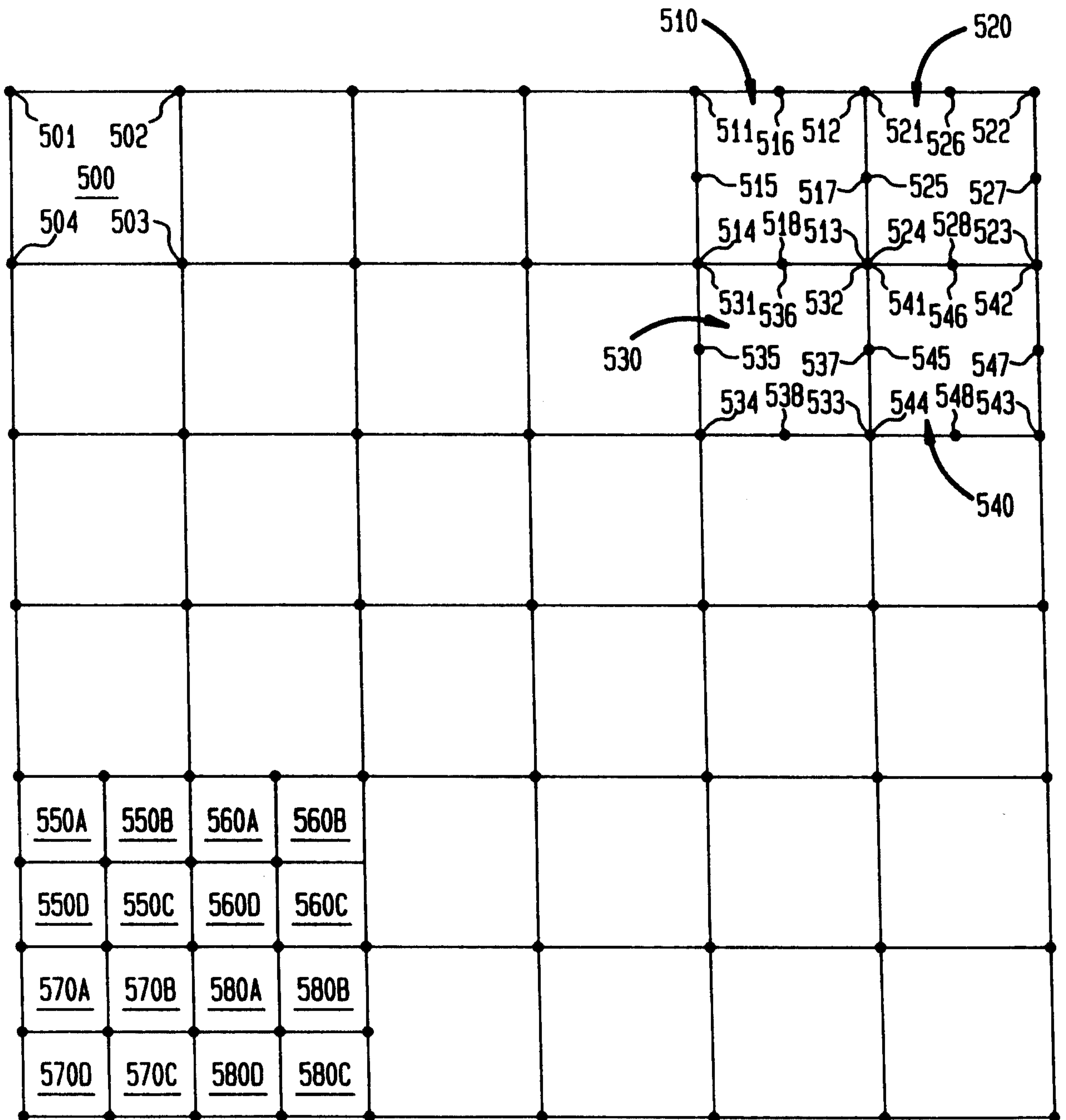

FIG. 22



9/9
FIG. 23

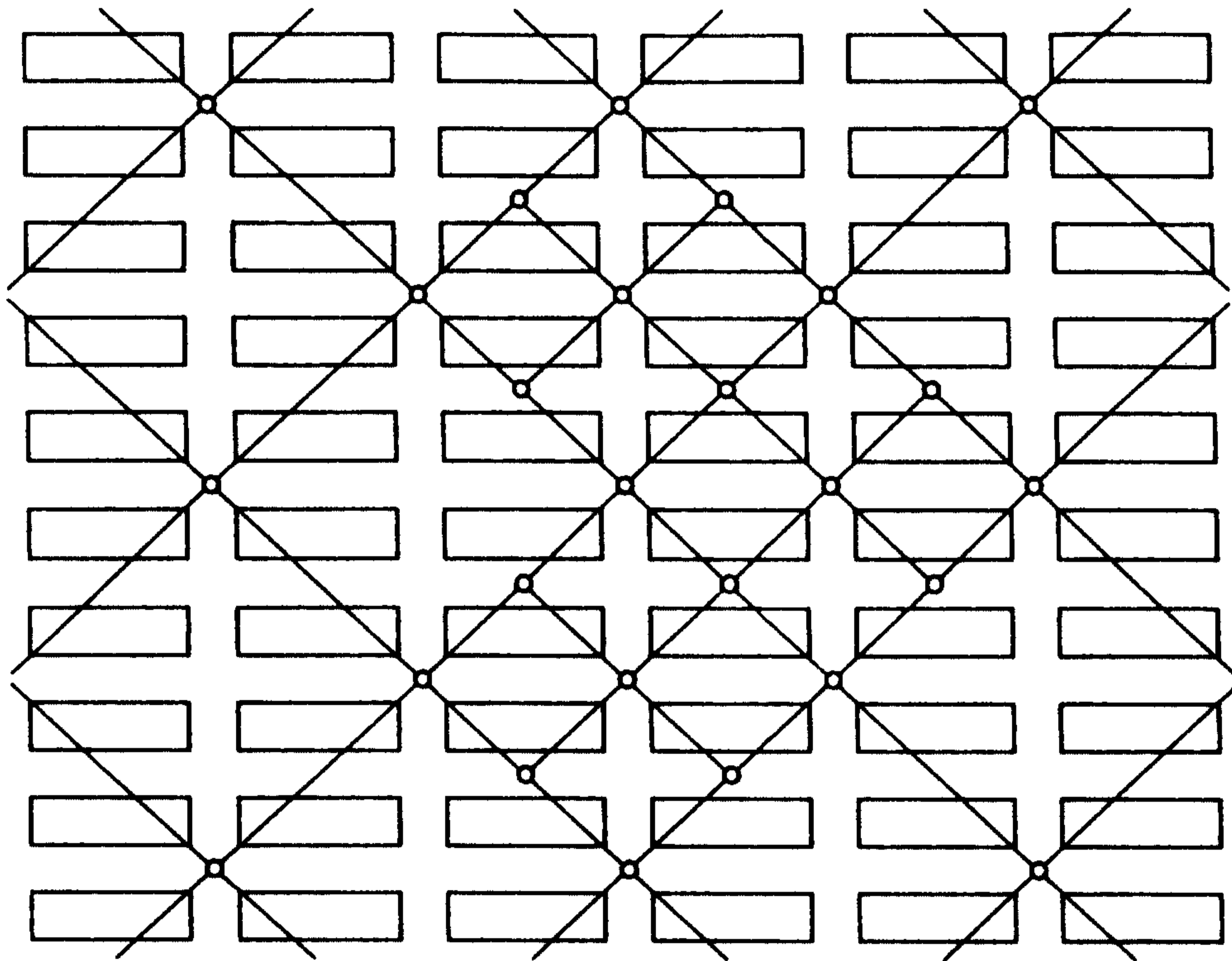

FIG. 24

