

(No Model.)

4 Sheets—Sheet 2.

J. F. SEIBERLING.
SPRING MOTOR.

No. 524,792.

Patented Aug. 21, 1894.

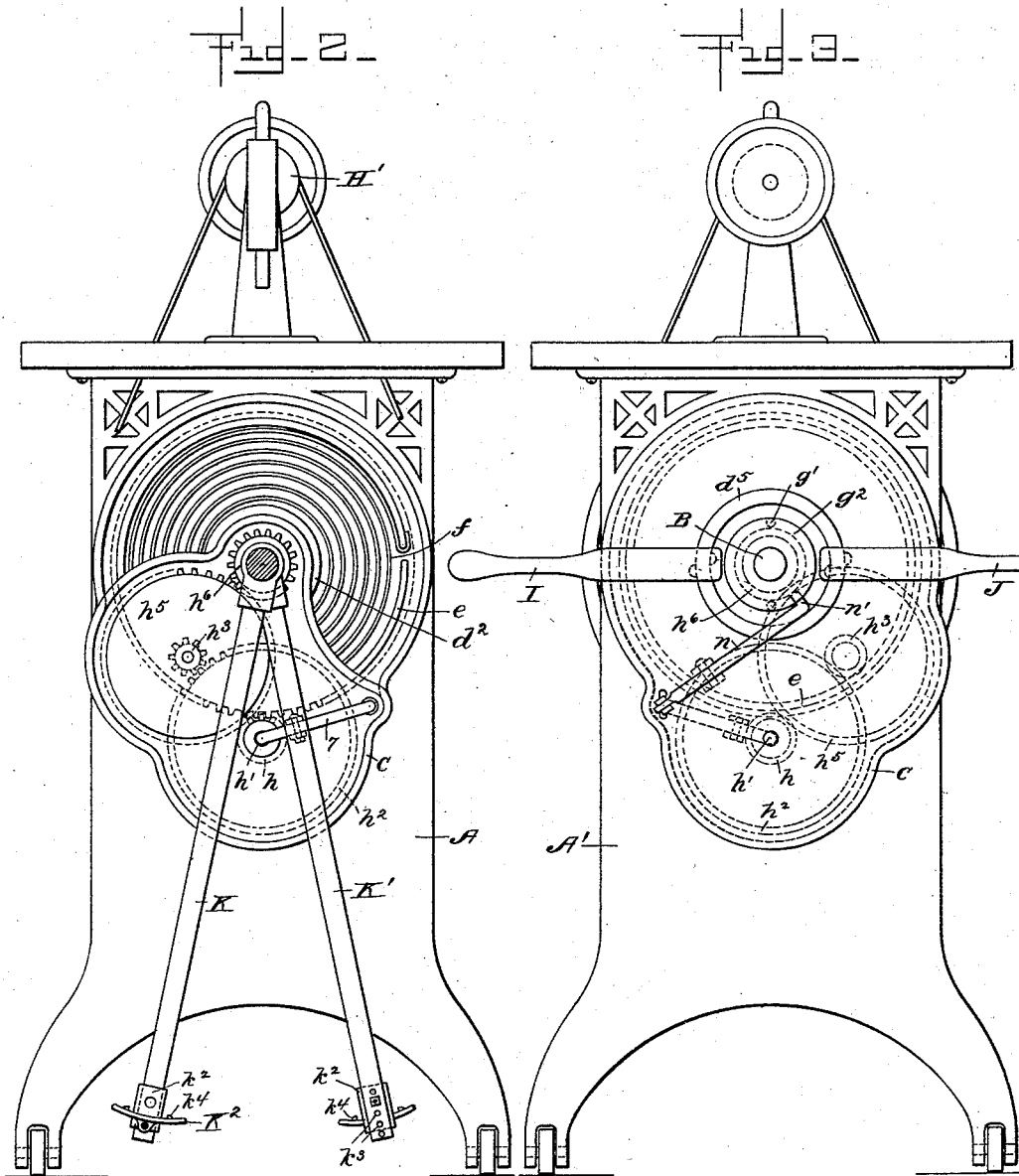

Witnesses
Wm. H. Kees
Theodore A. Day

Inventor
John F. Seiberling
By *Wm. Smith & Son*,
Attorneys.

(No Model.)

4 Sheets—Sheet 3.

J. F. SEIBERLING.
SPRING MOTOR.

No. 524,792.

Patented Aug. 21, 1894.

Fig-4-

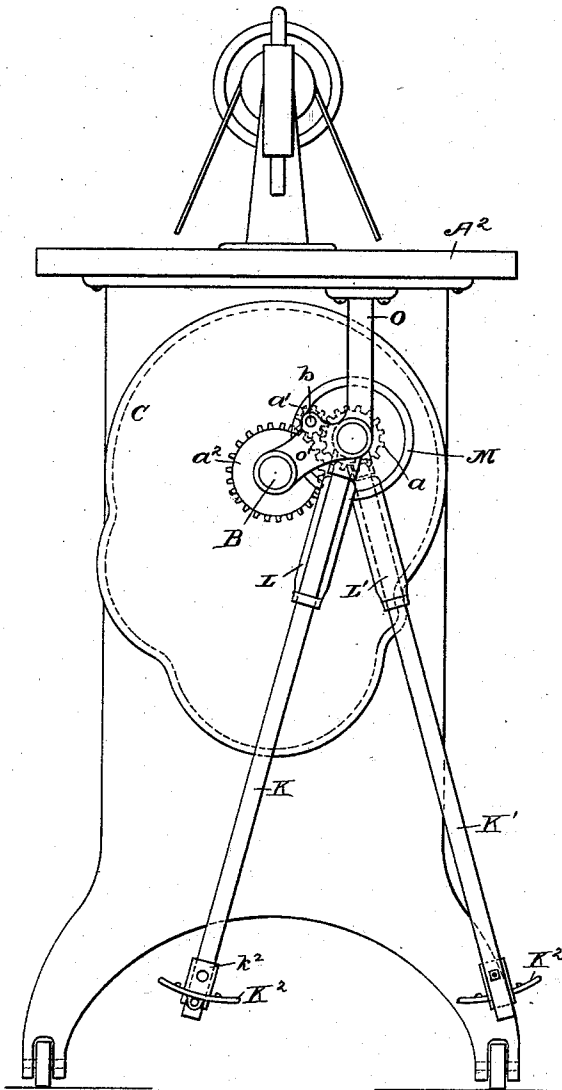
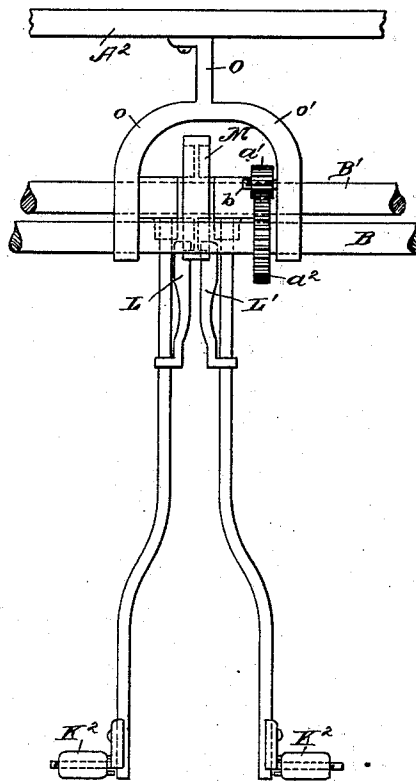

Fig-5-



Witnesses
Edw. H. Wells
Theodore A. Day

Inventor
John F. Seiberling,
By *Hell Smith & Son*
Attorneys.

(No Model.)

4 Sheets—Sheet 4.

J. F. SEIBERLING.
SPRING MOTOR.

No. 524,792.

Patented Aug. 21, 1894.

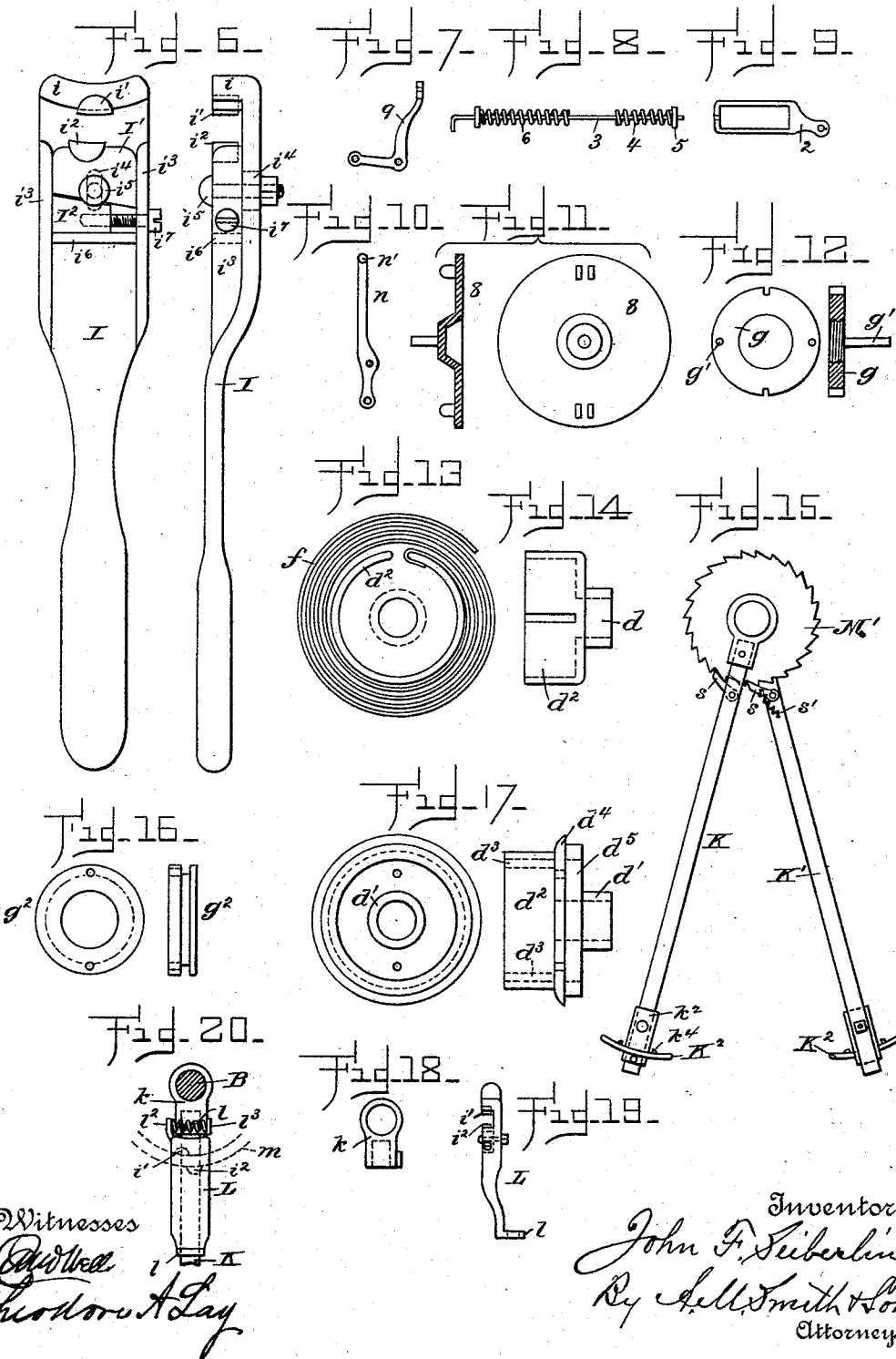

Witnesses
Edw. W. ...
Theodore A. Lay

Inventor
John F. Seiberling,
 By *Wm. Smith & Son,*
 Attorneys.

UNITED STATES PATENT OFFICE.

JOHN F. SEIBERLING, OF AKRON, OHIO.

SPRING-MOTOR.

SPECIFICATION forming part of Letters Patent No. 524,792, dated August 21, 1894.

Application filed November 14, 1893. Serial No. 490,955. (No model.)

To all whom it may concern:

Be it known that I, JOHN F. SEIBERLING, a citizen of the United States, and a resident of Akron, county of Summit, and State of Ohio, have invented a new and useful Improvement in Spring-Motors, of which the following is a full, clear, and exact description, reference being had to the accompanying drawings, making part of this specification.

My invention relates to that class of spring motors adapted for use in propelling sewing machines and other light machinery and employing a foot lever for winding the motor spring or springs and it consists in a novel arrangement of the levers relative to the main motor shaft and to the gearing connected therewith, and in the means for controlling the spring and regulating the expenditure of its power.

It further consists in certain details of construction and arrangement of parts of the motor, all as hereinafter described and claimed.

In the accompanying drawings:—Figure 1 is a front elevation of a machine, showing my improved motor, gearing, springs, and casing in section. Fig. 2 is an end elevation, looking from the outer or left hand end, with the outer, spring-casing plate removed to show the manner of attaching the spring to the main driving gear. Fig. 3 is an opposite end elevation to that shown in Fig. 2. Fig. 4 is a side elevation, showing a modification in the arrangement of the foot levers and gears for winding the springs and Fig. 5 is a front view of the same. Fig. 6 shows a face and a side view of the clamp levers. Figs. 7, 8, 9, 10, 11 and 12 are detail views of the brake or speed regulating mechanisms. Fig. 13 is an end view of a cylindrical spring arbor, showing the inner end of a spring connected with it, and Fig. 14 a plan view of said arbor. Fig. 15 is a side elevation, showing a modification in the foot lever gearing; Fig. 16, a side and end view of the grooved, sliding collar; Fig. 17, similar views of the spring winding arbor d' ; Fig. 18, a side view of the foot lever sleeve, and Fig. 19 a front view of a foot lever clamp. Fig. 20, shows the inner ends of a foot and clamp lever and the interposed spring.

A, A', indicate end uprights of the frame of the machine, which may be similar in con-

struction to the usual support or table of a sewing machine, A² indicating the table and B the main motor shaft, mounted and rotating in suitable bearings in the end uprights. The standard A' is perforated or otherwise adapted, near its upper end, to receive a gear-inclosing casing C, having suitable perforated hub projections c, c' , which surround and form bearings for hubs or sleeves on spring arbors d and d' , fast on the shaft B. These arbors, at their inner ends, abut against the ends of the hub of a gear wheel E, which adjacent to its toothed periphery, has laterally projecting, annular flanges e, e , which form drums, inclosing coiled springs f, f , the outer ends of which are secured to the flanges e , and so to the gear wheel E. The arbors d and d' , at their inner, adjacent ends, are enlarged or provided with disks, having inwardly projecting, annular flanges d^2 , surrounding the ends of the hub of wheel E, and forming cylindrical arbors through which the inner ends of the springs f , are secured to the shaft B. (See Fig. 13.)

The outer end or sleeve of the hub of wheel E is screw threaded and has a nut g mounted on it, which is notched or grooved, transversely on its periphery, (see Fig. 12,) to engage ways or ribs d^3 formed on the inner face of the annular flange d^2 , of the arbor, causing the nut to rotate with the latter and at the same time permitting it to travel laterally on the hub of the wheel E, as the spring is wound or unwound. In winding the springs, the nut g travels outward, away from the wheel E, its outward movement being limited or stopped by its abutting against the end of the arbor, and its inward movement, in the unwinding of the spring, by the wheel itself.

The disk d^4 , at the outer end of the cylindrical arbor d' , is extended beyond the cylinder and is provided on its outer face with an annular flange d^5 , which may be utilized in the application of power, for winding the springs, as will appear. The disk is perforated to permit the passage through it of rods g' , which, at their inner ends, are secured to the nut g , the outer ends of said rods being secured to a grooved collar g^2 (Fig. 16) sliding on the hub d' of the spring arbor, for a purpose which will appear.

The wheel E engages and drives a pinion

h , fast on a short transverse shaft h' , mounted in suitable bearings on the standard A' and in the casing C , and carrying, at its inner end, a spur gear h^2 , which, in turn, engages and
5 drives a pinion h^3 , fast on a short, secondary shaft h^4 , carrying a spur gear h^5 , and mounted in suitable bearings in the casing C .

H indicates a band pulley, mounted and rotating freely on the main shaft B and from
10 which motion is imparted to a pulley H' , on the sewing machine or other machine to be operated, in any usual manner. The hub of the pulley H has a pinion h^6 , fast on it, which engages and is driven by the spur gear h^5 for
15 actuating said band wheel H .

I , (see Figs. 3 and 6) indicates a hand lever which may be applied to the flange d^5 (see Figs. 3 and 17) for winding the springs, when
20 required, though, ordinarily, the winding will be effected by means of foot levers, hereinafter described. The lever I is enlarged in the detail view, Fig. 6, to show more clearly, the construction of the devices for clamping the
25 rim or annular flange d^5 . The inner clamp end of the lever is provided with a curved flange i , convex on its handle side or face, in which, at or near its center, is formed or otherwise rigidly secured, a clamping jaw i' , and
30 opposite thereto, is a block I' , adapted to slide or be adjusted toward or away from the jaw i' , in ways or ribs i^3 , formed at the sides of the lever, as shown. In the face of this block, and slightly to one side, or out of line with the jaw i' , is a second or opposing jaw i^2 .
35 The lever I is provided underneath the block I' , with a longitudinal slot at i^4 and a retaining bolt i^5 passing through the block and said slot in the lever, serves to hold the block at any desired adjustment the slot permitting
40 the adjustment when the nut on the bolt is loosened. The rear or outer end of the block I' , is inclined, as shown, and between said end and a transverse rib or offset at i^6 , on the lever, is a wedge I^2 , which can be adjusted,
45 by means of a set screw i^7 , for adjusting the block I' and jaw i^2 , as desired.

The jaws i' and i^2 are set sufficiently far apart to permit the rim d^5 to rotate freely between them, when the lever is held with the
50 jaws approximately in a line radial to the shaft of disk d^4 , but when the lever is vibrated to throw the jaw i^2 in advance of the jaw i' , the two are thrown toward the opposite walls of the rim and are made to grasp
55 the rim firmly and thus, by the further movement of the lever, to rotate the spring arbor for winding up the spring thereon. A backward movement of the lever causes the jaws to release the rim until the lever is again in
60 position to re-engage the rim for the further winding of the spring.

J , Fig. 3, indicates a retaining lever, provided with jaws, similar to those of the hand lever I , except that the relation of the jaws
65 is reversed so that they serve to hold the rim d^5 and shaft B against backward movement while the lever I is backed to take a new

grasp. The clamping levers used in connection with the foot levers hereinafter referred to, are also provided with clamping jaws, 70 similar to those of the hand lever I , above described.

K and K' indicate the foot levers, secured at their pivoted ends in socketed arms, formed on sleeves k (Fig. 13,) surrounding the
75 shaft B and embracing between them a disk or wheel M , fast on the shaft B and provided at its periphery with a rim or annular flange m , on each side. The sleeves k are held against lateral displacement by collars k' , k'' ,
80 fastened to the shaft B .

L and L' are clamp levers, (see Fig. 19) provided on their outer swinging ends, each, with a loop or stirrup l , which embraces one of the
85 foot levers, the adjacent faces of the said clamping levers being provided with jaws similar to those of the hand lever, above described, so that as the foot levers are vibrated
90 back and forth, the clamp levers will alternately clamp the rim of wheel M , for rotating it and the shaft B and spring arbors for winding up the spring, and then release their
95 hold to permit the foot levers to be retracted in a manner that will be readily understood.

For controlling the expenditure of the
95 power of the springs and the speed of the machine operated thereby, the grooved collar g^2 , sliding on the hub of the spring arbor, has engaging it a pin or spur n' , formed on one
100 end of lever n , pivoted in a lug or bracket n^2 on the casing C and having its opposite end connected to a yoke 2, sliding on a rod 3 and
105 inclosing a spiral spring 4, surrounding said rod. The end of rod 3, within the yoke 2, has a nut 5 on it against which the adjacent end of the spring 4 presses, the opposite end of
110 said spring pressing against the inner perforated wall of the yoke. The inner end of the rod 3, outside of the yoke 2, has also a spiral spring 6, surrounding it and is attached
115 to one end of a lever 7, pivoted to a lug on the casing, the opposite end of said lever 7 carrying or bearing against a brake plate or disk 8, surrounding the shaft h' and pressed
120 by the action of said lever and springs against the wheel h^2 . Intermediate the yoke 2 and the spring 6, the rod 3 passes through an eye in the upright arm of a bell-crank or elbow
125 lever 9, the horizontal arm of which is connected by a rod 10, with a treadle 11, by pressure upon which with the foot, the operator can compress the spring 6, more or less, as required and so press the brake plate against
130 the gear wheel h^2 , with sufficient force to stop its rotation, or to regulate its speed, as desired.

It will be seen that as the grooved collar g^2 is moved outward by the nut g , in winding up the springs, it throws the connecting end of the lever n , outward and the opposite end of
135 said lever, moving in the opposite direction, carries the yoke 2, inward, compressing the spring 6, thereby increasing the pressure of the brake plate on the wheel h^2 , as the power

or tension of the motor springs e , is increased, while, as the motor springs unwind, in propelling the main gear wheel E, the collar moves inward again, gradually diminishing the tension on the spring 6, and the pressure of the brake plate, as the tension of the motor springs is diminished, thereby automatically rendering the action of said springs nearly uniform.

The foot levers are provided with treads K^2 , of any approved form, pivoted to flanged or socketed blocks k^2 , secured to the lower ends of the levers and adapted by means of a series of perforations at k^3 , (Fig. 2.) and a through bolt, to be adjusted to any height required to suit the operator. These foot plates K^2 , are provided with stops k^4 , which limit their play or vibration.

In Figs. 4 and 5, the foot levers, instead of being applied directly to the main shaft as a fulcrum, are shown journaled on a short shaft B' , mounted in a pendent bracket or hanger O, secured to the table A^2 . The lower end of this hanger is forked as shown in Fig. 5, and is extended in angular form, as shown in Fig. 4 to form bearings also, for the main shaft B, thereby holding the two shafts in fixed relation to each other. The flanged or rimmed clamp wheel M is secured to the shaft B' , between the arms o, o' , of the hanger O, and adjacent to an arm of said fork, the shaft B has a spur gear a , fast on it, engaging a pinion a' , on a stud shaft b , on the arm o' , of the hanger O. The pinion a' , engages and operates a spur gear a^2 , fast on the main shaft B, for rotating the latter and winding the springs.

The foot levers when at rest or in their normal position, hang pendent from the shaft with the clamp levers thrown out of engagement with the rim of the wheel M and engage the latter only when vibrated by the operator for that purpose.

In Fig. 15, the shaft B is shown provided with a ratchet disk M' , in lieu of the flanged wheel M, and the foot levers are provided with pawls s, s , held in engagement with the ratchet disk by springs s' , in lieu of the clamp levers. In some instances, this construction may be found desirable, but the clamp lever represents the preferred device for winding the springs, as, in practice, it is found that with it, there is less lost motion in engaging the winding wheel.

To prevent lost motion, as far as practicable, springs l are interposed between lugs l^2 on the inner ends of the clamp levers and lugs l^3 on the foot-lever sleeves, said springs serving to hold said ends of the clamp levers with the jaws i^1 and i^2 in close contact with the rim while the levers are being retracted to take a fresh hold, said jaws being thus held always in position to instantly grasp the rim m when the levers are operated for that purpose.

Ordinarily only the foot levers will be required for the winding of the springs and said levers enabling the operator to operate with both feet, each independently of the other,

the springs can be quickly and easily wound, but where, from any cause, the operator is unable to use the feet, the hand lever can be employed and either can be used independently of the others, or all simultaneously.

By the employment of the two foot levers the spring can be wound in about half the time that it could be done by the employment of the hand lever only, as one foot can recede as the other advances, thus making "double quick" time.

In winding the springs, either the foot levers or the hand lever or both, may be used, as stated, the retaining lever J, in either case serving to prevent backward motion of the winding wheel and motor shaft while the operating lever or levers are being retracted to take a new hold of the driving wheel.

As the shaft B is rotated, carrying the arbor d' with it, the latter acts on the nut g to rotate it, and said nut acted upon by the screw threaded hub of the gear wheel, is forced outward or away from the gear wheel, until it abuts against the inner end or wall of the arbor disk, when its further movement is stopped and the winding of the spring is complete. In this movement of the nut g , the brake plate 8, through its connections with said traveling nut, is forced snugly against the side of the intermediate gear wheel h^2 and is thus made to give the greatest resistance to the motion of the spring, at the moment when the tension of the spring is greatest. When the motor is started, as the gear wheel rotates, the nut g , is made to travel inward on the rotating, screw-threaded hub thereof, thereby gradually diminishing the pressure and resistance of the brake plate to the action of the motor spring, as the tension of the spring is diminished, until the nut abuts against the gear wheel disk, when the force of the spring will be expended and re-winding will be necessary.

The treadle connected to the brake plate enables the operator to give increased resistance to the action of the spring and to stop the action of the motor, as required.

As the gear wheel E is rotated by the action of the motor spring, motion is imparted through the train of intermediate gear wheels described, to the band pulley on the motor shaft and thence to the sewing machine or other machine to be operated, in any suitable manner.

Having thus described my invention, what I claim as new, and desire to secure by Letters Patent, is—

1. In a spring motor, the combination with the motor shaft, of the gear wheel rotating thereon, the coiled motor spring surrounding said shaft and connecting it with the gear wheel, the winding wheel connected to said shaft, and the two pendent foot levers, independently pivoted to the winding wheel shaft on opposite sides of and connected to said interposed winding wheel, substantially as described.

2. In a spring motor the motor shaft and the annularly flanged gear wheel rotating thereon and provided with the screw threaded hub, in combination with the annularly flanged arbor fast on said shaft, the coiled spring surrounding the shaft and connecting said arbor and gear wheel, the nut engaging the arbor flange and traveling on the screw threaded wheel hub for limiting the winding and unwinding of the spring and means for winding said spring, substantially as described.

3. The combination in a spring motor, of the main motor shaft the flanged gear wheel rotating on said shaft and provided with a screw-threaded hub, the flanged spring arbor fast on said shaft the coiled spring connecting said wheel and arbor, the foot levers connected to said shaft for winding the spring and the nut engaging the spring arbor and traveling on the screw-threaded wheel hub for limiting the winding and unwinding of the spring, substantially as described.

4. The combination in a spring motor and with the main shaft thereof, of the gear wheel rotating on said shaft and having the screw-threaded hub and an annular flange forming the spring inclosing drum, the spring arbor having an annular flange surrounding the screw-threaded wheel hub, the motor spring connecting said flanged wheel and arbor, the nut engaging said arbor and traveling on the screw-threaded hub, the spring winding wheel connected to the motor shaft, and a lever engaging said wheel for winding the spring, substantially as described.

5. The combination of the motor shaft, the coil springs connected therewith, as described, the winding wheel fast on said shaft, the pendent foot levers pivoted to said shaft on each side of said winding wheel, winding levers loosely connected at their lower ends to said foot levers and their upper ends connected with the winding wheel by suitable connections to engage the wheel, to rotate the same, to wind up the springs, substantially as described.

6. In a spring motor the double-flanged, spring-winding wheel and the shaft on which said wheel is mounted, in combination with the pendent winding levers pivoted on said shaft, one on each side of and engaging the flanges of said interposed winding wheel, substantially as and for the purpose described.

7. In a spring motor, the combination of the motor shaft, a gear wheel E rotating thereon, a coiled spring surrounding said shaft and having one end connected with said shaft and the other with said gear wheel, a gear pinion h meshing with said wheel E and connected with gear wheel h^2 , gear pinion h^3 , meshing with said gear wheel h^2 and connected with

gear wheel h^5 , gear pinion h^6 , the gear wheel h^5 engaging, and the band wheel H connected with said pinion, said band wheel and pinion h^6 , being supported upon and revolving around said motor shaft, a winding wheel fast on said motor shaft and a pendent foot lever on each side of and connected with said wheel, by suitable connections to rotate the same, all arranged for joint operation, substantially as described.

8. In a spring motor, the combination with the motor shaft, of the main gear wheel provided with a screw-threaded hub, a spring arbor fast on said shaft, a motor spring connecting said gear wheel and arbor, a band pulley on said shaft, intermediate gear wheels connecting the main gear wheel and said band pulley for actuating the latter, a brake plate acting on an intermediate gear wheel, and a nut traveling on the screw-threaded wheel hub and connected to said brake plate for regulating the resistance to the force of the spring, substantially as described.

9. The combination with the motor shaft of the main gear wheel rotating on said shaft and having a screw-threaded hub, a spring arbor fast on said shaft, the motor spring connecting said wheel and arbor, a band pulley on said shaft geared to and actuated from said main gear wheel, a brake plate acting on an intermediate gear wheel for controlling the speed of the motor, a nut traveling on the screw-threaded hub and connected to said gear plate and a treadle also connected to said gear plate for controlling the speed of and stopping the motor, substantially as described.

10. In a spring motor the flanged spring winding wheel, in combination with a lever for actuating said wheel, provided with the fixed jaw i' , the adjustable block I' , carrying the jaw i^2 , and the adjustable wedge I^2 and its adjusting screw i^7 , for adjusting one clamping jaw relative to the other, substantially as described.

11. The combination in a spring motor, of the winding wheel provided with the annular rim or flanges m, m , the pendent foot levers arranged on opposite sides of said wheel, the clamp levers connected one to each foot lever, to engage said interposed winding wheel and the springs interposed between clamp levers and foot levers, substantially as and for the purpose described.

In testimony whereof I have hereunto set my hand this 11th day of November, A. D. 1893.

JOHN F. SEIBERLING.

Witnesses:

W. H. CARTER,
W. G. WISE.