

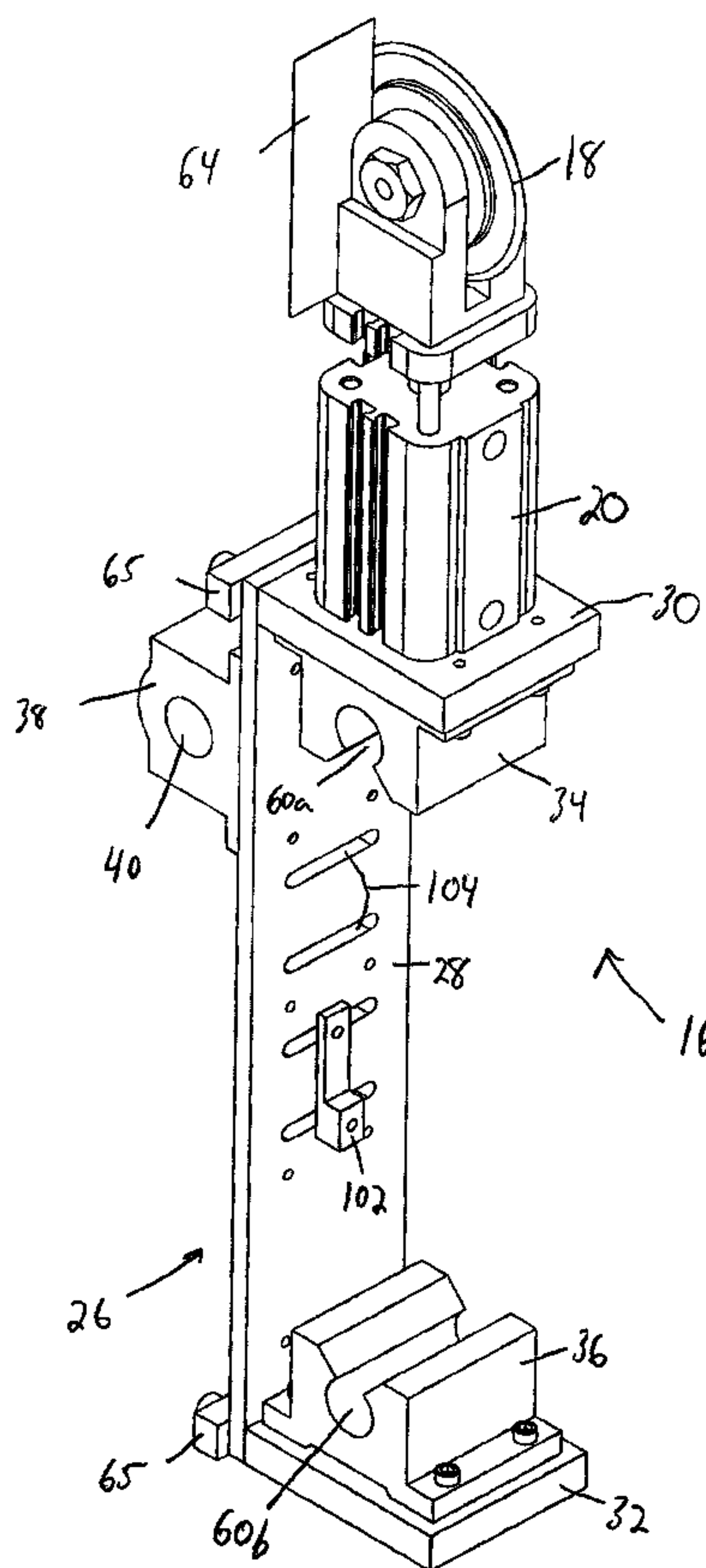

(22) Date de dépôt/Filing Date: 2003/12/02
 (41) Mise à la disp. pub./Open to Public Insp.: 2004/09/07
 (45) Date de délivrance/Issue Date: 2009/09/01
 (30) Priorité/Priority: 2003/03/07 (US10/384,436)

(51) Cl.Int./Int.Cl. *B31C 3/00* (2006.01),
B65H 18/10 (2006.01), *B65H 35/02* (2006.01)
 (72) Inventeurs/Inventors:
BLUME, JOSEPH A., US;
HOLZEM, JAMES VINCENT, US;
JANSEN, STEVE J., US
 (73) Propriétaire/Owner:
WAUSAU PAPER TOWEL & TISSUE, LLC, US
 (74) Agent: GOUDREAU GAGE DUBUC

(54) Titre : METHODE ET DISPOSITIF DE REDUCTION D'AME
 (54) Title: CORE REDUCTION METHOD AND APPARATUS



(57) Abrégé/Abstract:

Apparatus and processes for producing paper roll products with spaced core sections. A core substrate is arranged on a mandrel, and then divided into a plurality of core sections. The core sections are then separated from each other on the mandrel to form gaps between the core sections. Paper web material can then be wound onto the separated core sections to form a log of rolls. The log is then cut into final paper roll products.

ABSTRACT

Apparatus and processes for producing paper roll products with spaced core sections. A core substrate is arranged on a mandrel, and then divided into a plurality of core sections. The core sections are then separated from each other on the mandrel to form gaps between the core sections. Paper web material can then be wound onto the separated core sections to form a log of rolls. The log is then cut into final paper roll products.

CORE REDUCTION METHOD AND APPARATUS

FIELD OF THE INVENTION

The invention disclosed herein relates to paper roll products with cores, and
5 more particularly to processes and apparatus for reducing the amount of core stock
used in paper roll products.

BACKGROUND OF THE INVENTION

Paper roll products, such as toilet tissue rolls and paper towel rolls, typically
10 include a paper web material that is wound around a central core. The core helps to
support the paper web material and define the shape of the roll, as well as define a
central opening for interaction with a support structure, such as a spindle, on a
suitable dispensing apparatus.

In many paper roll products, the core is a one piece structure that extends the
15 entire width of the roll product.

In some known paper roll products, the core is formed by core sections that
are spaced apart from each other to form a gap therebetween so that the total length
of the core sections is less than the width of the web material wound onto the core
sections. See, for example, U.S. Patents 3,437,388 and 3,438,589 to Jespersen. The
20 provision of spaced core sections separated by a gap helps to reduce the amount of
core stock material that is used, thereby reducing production costs. In some
instances, such as in the aforementioned Jespersen patents, the spaced core sections
also function to indicate to a user the depletion of the web material from the roll.

There is a continuing need for paper roll products with spaced core sections,
25 and for processes and apparatus used in the production of such paper roll products.

SUMMARY OF THE INVENTION

The invention relates to apparatus and processes for producing paper roll
products with spaced core sections. The apparatus and processes described herein
30 can be used to produce paper roll products of the type disclosed in, for example, U.S.
Patent 6,491,251.

In accordance with a first aspect of the invention, a process for producing
core sections for use in producing paper roll products is provided. The process
includes providing a core substrate; arranging the core substrate on a mandrel;
35 dividing the core substrate into a plurality of core sections; and separating at least
one core section from an adjacent core section on the mandrel to form a gap
therebetween.

Preferably, each core section is separated from an adjacent core section to form a gap between each of the core sections. By separating the core sections, and subsequently winding paper web material onto the core sections, paper roll products with spaced core sections can be produced.

5 In another aspect of the invention, a process of manufacturing cored paper roll products is provided. The process includes arranging a core substrate on a mandrel; dividing the core substrate into a plurality of core sections; separating the core sections from each other on the mandrel to form a gap between each of the core sections; and winding paper web material onto the core sections.

10 In yet another aspect of the invention, an apparatus for forming paper roll products is provided. The apparatus includes a mandrel having a longitudinal axis, and a core slitter assembly positioned adjacent the mandrel. The core slitter assembly has a plurality of slitter mechanisms, and the slitter mechanisms are mounted to be moveable between a non-cutting position where the slitter
15 mechanisms are away from the mandrel and a cutting position where the slitter mechanisms are positioned to cut a core substrate disposed on the mandrel into a plurality of core sections. In addition, a plurality of the slitter mechanisms are mounted to be moveable relative to the mandrel in a direction parallel to the longitudinal axis.

20 These and various other advantages and features of novelty which characterize the invention are pointed out with particularity in the claims annexed hereto and forming a part hereof. However, for a better understanding of the invention, its advantages and objects obtained by its use, reference should be made to the drawings which form a further part hereof, and to the accompanying
25 description, in which there is described a preferred embodiment of the invention.

DESCRIPTION OF THE DRAWINGS

These and other features of the invention will now be described with reference to the drawings of preferred embodiments, which are intended to illustrate
30 and not to limit the invention and in which:

Figure 1A illustrates a portion of an apparatus for forming paper roll products according to the invention, with a core slitter assembly in the non-cutting position;

Figure 1B illustrates the slitter mechanisms of the core slitter assembly in the
35 cutting position to divide the core substrate into a plurality of core sections;

Figure 2A is a perspective view of the core splitter assembly and an adjustment mechanism for one-half of the slitter mechanisms of the assembly.

Figure 2B is a bottom view of the core splitter assemblies showing each adjustment mechanism for each half of the slitter mechanisms.

Figure 3 illustrates one-half of the slitter assembly with the slitter mechanisms disengaged from the core sections along with an adjustment mechanism;

Figure 4 illustrates the gripper mechanisms of the slitter mechanisms engaged with the core sections;

Figure 5 illustrates the slitter mechanisms moved relative to the mandrel to space the core sections from each other;

Figure 6 illustrates a slitter mechanism in detail;

Figure 7 illustrates pivoting of the slitter mechanism to engage the gripper mechanism with the respective core section;

Figure 8 illustrates a position of the slitter mechanism where the gripper mechanism does not engage the core section;

Figure 9 illustrates a slitter mechanism in the non-cutting position;

Figure 10 illustrates the web material prior to beginning winding onto the spaced core sections;

Figure 11 illustrates a log of paper roll products after winding and after being removed from the mandrel;

Figure 12 illustrates a plurality of paper roll products after cutting the log; and

Figure 13 illustrates a paper roll product produced according to the invention.

DETAILED DESCRIPTION OF THE INVENTION

With reference to Figure 1A, a core substrate 10 is illustrated as being disposed on a mandrel 12 of a paper roll production apparatus. A paper roll production apparatus suitable for practicing the invention is the Centrum Center Winder available from Paper Converting Machine Company of Green Bay, Wisconsin. The core 10, which is conventional in construction, is preferably made from cardboard or other suitable paper-based material.

The core substrate 10 is loaded approximately onto the center of the mandrel 12. During loading, the mandrel fingers of the mandrel are retracted to allow loading. Once the core substrate 10 is in position, the mandrel fingers are extended in order to hold the core substrate in place. The use of mandrel fingers and their extension and retraction are known in the art. For example, see U.S. Patent 4,635,871. The mandrel 12 is mounted in known fashion so as to be rotatable in order to wind paper web material onto core sections formed from the core substrate 10.

Positioned adjacent the mandrel 12 is a core slitter assembly 14 according to the invention. The core slitter assembly 14 comprises a plurality of slitter mechanisms 16 that are configured to cut the core substrate 10 into a plurality of core sections. To accomplish cutting, each slitter mechanism 16 comprises a slitting head that includes a cutting disk 18, and a slitter cylinder 20 for actuating the slitting head toward and away from the mandrel 12. The cylinder 20 can be a pneumatic or hydraulic cylinder.

In Figure 1A, the cylinders 20 are disengaged so that the slitting heads are retracted to permit loading of the core substrate on the mandrel 12. In Figure 1B, the cylinders 20 are engaged to extend the slitting heads and the cutting disks 18 toward the mandrel 12 into cutting position for cutting the core substrate 10 into a plurality of core sections 22a, b, . . . n.

To achieve cutting, the mandrel 12 is rotated while the cutting disks 18 are engaged with the core substrate 10. During cutting, the mandrel fingers are preferably extended to assist in holding the core substrate, and the resulting core sections 22a . . . n in place on the mandrel. Driven back-up rollers 24a, 24b (shown in Figure 7) can also be used to assist the cutting process and limit bowing of the mandrel 12 during cutting.

The cutting disks 18 are shown as being oriented in a plane substantially perpendicular to the central axis of the mandrel 12 so that the cuts in the substrate 10 are made in a plane substantially perpendicular to the mandrel axis. However, the cutting disks 18 could be oriented so that the cuts that are made are slanted or angled relative to the mandrel axis.

In the preferred embodiment, the resulting core sections 22a . . . n each have a length that is approximately 2/3 of the desired width of the finished paper roll product. Other core section lengths could be used.

Mechanisms other than cutting disks 18 could be used to divide the substrate 10 into core sections 22a . . . n. For example, water jets or other industry methods could be used to divide the substrate into the core sections. After the substrate is divided into the core sections 22a . . . n, the core sections are separated from each other to form a gap between each core section.

With reference to Figures 2-5, further details of the slitter assembly 14 are illustrated. The slitter assembly 14 comprises first and second halves 15a, 15b each of which comprises a plurality of slitter mechanisms 16, as best seen in Figures 2A and 2B. Each slitter assembly half 15a, 15b is provided with an adjustment mechanism 25a, 25b that is connected to the slitter mechanisms 16. The adjustment mechanisms 25a, 25b are each configured and arranged to actuate the slitter mechanisms 16 in a direction parallel to the longitudinal axis of the mandrel 12.

Each slitter mechanism 16 is also configured and arranged to engage a core section such that when the slitter mechanisms are moved in a direction parallel to the mandrel 12, the core section 22a...n engaged by the respective slitter mechanism 16 moves with the slitter mechanism to achieve separation of the core sections.

5 Figures 6-9 illustrate one of the slitter mechanisms 16 in detail, it being understood that the other slitter mechanisms are substantially identical. The slitter mechanism 16 includes a support bracket 26 comprising a support plate 28 and first end plate 30 and a second end plate 32. As shown in Figure 6, the slitter cylinder 20 is mounted to one side of the end plate 30. In addition, a pair of bearing pads 34, 36 are mounted on the facing surfaces of the end plates 30, 32. Further, a slide block 38 defining a central opening 40 is fixed to the support plate 28. The purpose of the bearing pads 34, 36 and slide block 38 will become apparent later in the description.

10 With reference to Figures 2A, 2B and 3, the adjustment mechanism 25a will be described in detail. Figure 3 shows only the slitter assembly half 15a and its associated adjustment mechanism 25a, with the half 15b being removed for clarity. It is to be understood that, in operation, the slitter assembly half 15b would be positioned to the left of the half 15a in Figure 3, and that the core substrate would extend to the left in Figure 3 around the mandrel 12 to be engaged by the slitter assembly half 15b. In addition, it is to be understood that the adjustment mechanism 25b is identical in construction and function to the adjustment mechanism 25a, but is positioned on the opposite side of the slitter assembly 14 from the adjustment mechanism 25a as shown in Figure 2B.

15 The adjustment mechanism 25a comprises, in the illustrated embodiment, four rods 42a-d, the adjacent ends of which are fixed to a yoke 44. An actuating cylinder 46 has an actuating rod 48 that is fixed to the yoke 44 approximate the center thereof. The cylinder 46, which can be either pneumatically or hydraulically actuated, extends or retracts the rod 48, which moves the yoke 44 in a direction parallel to the longitudinal axis of the mandrel 12. Movement of the yoke 44 causes movement of the rods 42a-d, which in turn results in movement of the slitter mechanisms 16.

20 In the illustrated embodiment of the slitter assembly half 15a, there are three slitter mechanisms 16 disposed on each rod 42a-d, with the rods extending through the openings 40 in the slide blocks 38 of the respective slitter mechanisms. As shown in Figures 2A and 3, the slide blocks 38 of adjacent slitter mechanisms 16 are positioned at different locations along the length of the support plates 28. However, the position of the slide blocks 38 of the three slitter mechanisms on each rod 42a-d are positioned at the same position on the support plates 28.

The number of rods 42a-d and the number of slitter mechanisms 16 on each rod can vary depending upon the number of slitter mechanisms that are provided. In the illustrated embodiment, the slitter assembly half 15b includes 13 slitter mechanisms, so that one of the actuating rods associated therewith will have a
5 different number of slitter mechanisms thereon compared to the other actuating rods.

A plurality of actuators comprising extension actuators 50a and retraction actuators 50b are fixed to and move integrally with the rods 42a-d. The actuators 50a, 50b can comprise collars that are clamped onto the respective rods 42a-d. There is one extension actuator 50a positioned to the left of each slide block to
10 engage the left sides of the slide blocks 38 when the rods 42a-d move, thereby causing the slitter mechanisms to move to the left to a separated configuration (when viewing Figures 3-5). The separated configuration and the engagement of the extension actuators 50a with the left sides of the slide blocks are illustrated in Figure 5.

In addition, there is one retraction actuator 50b disposed on each rod 42a-d, with each actuator 50b being positioned to the right (when viewing Figures 3-5) of the rightmost slitter mechanism 16 on each rod 42a-d. As a result, when the rods
15 42a-d are retracted, the retraction actuators 50b engage the right sides of the rightmost slide blocks to initiate return of the slitter mechanisms to a home position. Blocks 65 (best seen in Figure 6) adjacent the top and bottom of the support plates
20 28 of the rightmost slitter mechanism 16 on each rod 42a-d engage the next adjacent slitter mechanism 16 as the rods continue to retract. Similar blocks are on the remaining slitter mechanisms, whereby as the rods retract, the slitter mechanisms stack up as they are pulled back to the home position. The home position, the
25 engagement of the retraction actuators 50b and the slide blocks, and a small gap between each slitter mechanism due to the blocks 65 is illustrated in Figure 3. A stop 52 that is fixed to a frame (discussed below) is provided to contact the leftmost slitter mechanism 16 to define the home position for the slitter mechanisms.

The actuators 50a, 50b are configured and arranged to effect sliding
30 movement of the slitter mechanisms 16 on the rods 42a-d from the home position shown in Figure 3 to the separated configuration shown in Figure 5, and back again to the home position with the aid of the blocks 65. The positioning of the actuators 50a, 50b on the rods 42a-d is such as to achieve equal spacing of the slitter mechanisms 16 in the separated configuration as shown in Figure 5. The distance
35 each slitter mechanism will move is the difference between the stroke of the cylinder 46 and each slide block's distance to the respective actuator 50a.

With reference to Figures 2A, 3, and 4, stops 100 are fixed to a frame 54 (to be later described) on each side thereof. There is one stop 100 for each slitter

mechanism 16 of each of the slitter assembly halves 15a, 15b. Each slitter mechanism 16 includes a stop block 102, shown in Figure 6, that is fixed to the plate 28 at a location for engagement with one of the stops 100. Each stop block 102 is adjustable upward and downward vertically on the respective plate 28 through the use of bolts that extend through slots 104 in the plate 28 for adjusting the vertical position of the block 102.

The shape and position of the blocks 102 on the slitter mechanisms 16 are such that the blocks 102 engage a respective stop 100 once the slitter mechanisms 16 have been pushed into the separated configuration by the rods 42a-d, as shown in Figure 5 for the slitter mechanisms 16 of the slitter assembly half 15a. The engagement between the blocks 102 and the stops 100 prevents the slitter mechanisms 16 from floating or moving further after they have been actuated into their separated positions.

With reference to Figure 4, the distance L between the right side of the actuator 50a and the left side of the slide block 38 for the leftmost slitter mechanism 16 on the rod 42a is illustrated. The distance L defines the distance the actuator 50a must move in order to cause movement of the slitter mechanism 16. This distance gets smaller for rod 42b, smaller again for rod 42c, and smaller again for rod 42d. Similar distance relationships exist for the other actuators 50a and slide blocks on the rods 42a-d. Thus, a single stroke of the cylinder 46 moves the slitter mechanisms 16 to the positions shown in Figure 5.

The slitter mechanisms 16 are configured and arranged to engage the core sections so that the core sections move with the slitter mechanisms. The means for engaging and separating the core sections will now be described with reference to Figures 7-8 along with Figures 2-6. As shown in Figures 2A, 3 and 7, a rectangular frame 54 extends approximately the entire length of the mandrel 12 parallel thereto. The frame 54 is mounted for pivoting movement about a pivot axis A shown in Figures 4 and 7. As shown in Figures 2A and 3, the cylinder 46 is mounted to the side of the frame 54.

Slide rails 56a, 56b are fixed at the top and bottom of a portion of the frame 54. The slide rails 56a, 56b include rounded edges 58a, 58b that are received within rounded pockets 60a, 60b formed in the bearing pads 34, 36 of the slitter mechanisms 16. The slide rails 56a, 56b within the pads 34, 36 permit sliding movement of the slitter mechanisms 16 relative to the frame 54. A pivot cylinder 62 is connected to the frame to cause pivoting movement of the frame 54, and the slitter mechanisms 16 disposed thereon, about the pivot axis A.

The disks 18 are used to affect separation of the core sections by pushing the core sections into place as the rods 42a-d are actuated by the cylinder 46. To

facilitate sliding of the disks 18 relative to the mandrel 12 after the disks have cut the core sections 22a...n, the pressure in the cylinders 20 is lowered from that used during the cutting phase. For example, during cutting of the core substrate 10 by the disks 18, the pressure in the cylinders 20 is about 60 psi, which is reduced to about 5 10 psi when the disks 18 push the core sections.

With reference to Figure 6, the slitter mechanism 16 includes a gripper mechanism 64 that is configured and arranged to engage a core section 22a...n as the slitter mechanism 16 moves along the respective rod 42a-d. In the illustrated embodiment, the gripper mechanism 64 comprises a plate that is made of a flexible material, such as spring steel. The plate is disposed adjacent the disk 18 and projects beyond the end of the disk 18, as shown in Figures 7-9. To increase friction between the gripper mechanism 64 and the core section, barbs or other friction enhancing features could be provided on the gripper mechanisms. The gripper mechanisms 64 apply light pressure to the core sections to prevent the core sections from sliding after the disks 18 have pushed them into position. 10 15

The operation of the entire apparatus will now be described. Initially, with the cylinder 20 disengaged, a core substrate 10 is loaded onto the mandrel 12. With the cylinder 20 disengaged, the disk 18 and gripper mechanism 64 are away from the mandrel 12, which permits loading of the core substrate without interference from the disk 18 or gripper mechanism 64 (see Figures 1 and 9). Once the core substrate is in position, the cylinder 20 is engaged while the pivot cylinder 62 is extended. This brings the disks 18 into position to cut the core substrate 10 into the core sections (see Figures 2 and 8). The mandrel 12 is then rotated at least one full revolution, so that the disks 18 cut the core substrate 10 into the core sections. 20

With the pivot cylinder 62 extended, the gripper mechanism 64 is not engaged with the core substrate (see Figure 8). With the cylinder 20 still engaged, the pivot cylinder 62 is retracted which pivots the frame 54 and the slitter mechanisms 16 of both slitter assembly halves 15a, 15b in a clockwise direction around the pivot axis. This movement brings the gripper mechanisms 64 into engagement with the core sections while maintaining the disks 18 in engagement with the core sections (see Figures 4 and 7). With the gripper mechanisms engaged with the core sections, the cylinder 46 of each actuating mechanism 25a, 25b is then actuated to move the slitter mechanisms 16 parallel to the mandrel 12. With reference to Figure 2A, the slitter mechanisms 16 of the slitter assembly halve 15a will be moved to the right, while the slitter mechanisms 16 of the slitter assembly halve 15b will be moved to the left. The core sections are moved by the disks 18, thereby separating the core sections on the mandrel 12 (see Figure 5). After the core 25 30 35

sections are moved, the mandrel fingers will again be engaged in order to hold the core sections in place during winding of the web material.

As described above, each core section 22a...n preferably has a length that is approximately 2/3 of the desired width of the finished paper roll product. Further, it is preferred that the gap that is formed between each core section after separation is substantially 1/3 of the width of the finished paper roll product.

Turning to Figure 10, once the core sections are separated, a paper web material 70 is then wound onto the core sections by rotating the mandrel 12 until a desired thickness is achieved. The paper web material is preferably toilet tissue. However, other paper webs could be used, for example paper towels and other paper products that are wound onto cores.

Once the desired thickness is achieved, the now formed log 72 of rolls is removed from the mandrel 12, as shown in Figure 11. The log 72 is then cut approximately through the center of each core section along cut lines CL as shown in Figure 11. The log 72 is preferably saw cut, although other cutting techniques could be used as well.

The result, as illustrated in Figures 12 and 13, is a plurality of finished paper roll products 80, each of which comprises a pair of core sections 82a, 82b that are spaced apart from one another by a gap 84 approximate the center of the product 80, and paper web material 86 wound onto the core sections 82a, 82b. A pair of scrap rolls 88a, 88b are formed at the ends of the log, which can be recycled or thrown away.

Many other configurations and methods could be used to produce a paper roll product according to the principles of the invention. For example, the web 70 could be slit as the web is being wound onto the mandrel 12. At the same time, slitters could be used to cut the core sections during winding to cut the core sections to correct size. This would eliminate the need for a log saw to cut a log down into separate roll products.

In addition, the gap 84 between the core sections 82a, 82b could be closer to one end of the product 80 than the other end. Further, the product could be formed with only one core section, in which a gap would exist at one end of the product or, if the single core section is located between the ends of the product, gaps would exist at each end.

Moreover, rather than separating the core sections after cutting the core substrate, the core substrate could be cut into full length cores and then a slitter could cut the gap section out of the full length core section. The cut section would then be cut away from the mandrel and then recycled.

Instead of using the disks to separate the core sections, the gripper mechanisms 64 could be used to achieve core section separation. In this embodiment, the disks would disengage from the core sections when the pivot cylinder 62 retracts, and the gripper mechanisms would need to be designed to engage the core sections with sufficient force to achieve separation.

Further, gripping mechanisms other than plates could be used, for example plastic or rubber fingers with or without friction enhancing features such as barbs. Further, instead of pivoting the frame 54, the gripper mechanisms themselves could be provided with separate actuators to affect engagement with the core sections.

The embodiments of the inventions disclosed herein have been discussed for the purpose of familiarizing the reader with novel aspects of the invention. Although preferred embodiments have been shown and described, many changes, modifications, and substitutions may be made by one having skill in the art without necessarily departing from the spirit and scope of the invention.

15

WE CLAIM:

1. A process for producing core sections for use in producing paper roll products, comprising:
 - providing a core substrate;
 - 5 arranging the core substrate on a mandrel;
 - dividing the core substrate into a plurality of core sections; and
 - separating at least one core section from an adjacent core section on the mandrel to form a gap therebetween.
- 10 2. The process of claim 1, wherein the core substrate is loaded onto the mandrel.
3. The process of claim 1, wherein the core substrate is divided into more than two core sections.
- 15 4. The process of claim 1, wherein dividing the core substrate comprises cutting the core substrate into the plurality of core sections.
5. The process of claim 1, comprising separating each core section from
20 an adjacent core section to form a gap between each of the core sections.
6. The process of claim 5, wherein the core sections are separated by sliding a plurality of the core sections relative to the mandrel.
- 25 7. The process of claim 5, wherein each core section has a length that is approximately $2/3$ of the desired paper roll product width.
8. The process of claim 5, wherein each gap is approximately $1/3$ of the width of the desired paper roll product width.
- 30 9. A process of manufacturing cored paper roll products, comprising:
 - arranging a core substrate on a mandrel;
 - dividing the core substrate into a plurality of core sections;
 - separating the core sections from each other on the mandrel to form a gap
35 between each of the core sections; and
 - winding paper web material onto the core sections.

10. The process of claim 9, wherein the web material is a continuous paper web that is wound onto all of the core sections to produce a roll product log, and further comprising cutting the log into a plurality of individual roll products.

5 11. The process of claim 9, wherein the web material is a plurality of paper webs.

12. The process of claim 9, wherein the core substrate is divided into more than two core sections.

10

13. The process of claim 9, wherein dividing the core substrate comprises cutting the core substrate into the plurality of core sections.

14. The process of claim 9, wherein the core sections are separated by sliding a plurality of the core sections relative to the mandrel.

15

15. The process of claim 10, comprising removing the log from the mandrel prior to cutting the log.

20

16. The process of claim 10, comprising cutting the log approximately through the center of each core section.

17. The process of claim 9, wherein each core section has a length that is approximately $2/3$ of the desired paper roll product width.

25

18. The process of claim 9, wherein each gap is approximately $1/3$ of the width of the desired paper roll product width.

30

19. An apparatus for forming paper roll products, comprising:
a mandrel having a longitudinal axis; and
a core slitter assembly positioned adjacent the mandrel, the core slitter assembly having a plurality of slitter mechanisms, each slitter mechanism includes a cutting disc and a gripper mechanism, and the slitter mechanisms are mounted to be pivotable between a non-cutting position where the slitter mechanisms are away from the mandrel, and a cutting position where the cutting discs are positioned to cut a core substrate disposed on the mandrel into a plurality of core sections and the gripper mechanisms are engageable on an outer surface of the core sections on the mandrel, and the plurality of slitter mechanisms are mounted to be moveable relative to the mandrel in

35

a direction parallel to the longitudinal axis to space apart the core sections along the longitudinal axis while the gripper mechanisms maintain engagement with the outer surface of the core sections.

5 20. The apparatus according to claim 19, wherein the core slitter assembly further includes an adjustment mechanism configured to move the slitter mechanisms relative to the mandrel in the direction parallel to the longitudinal axis.

10 21. The apparatus according to claim 19, wherein each gripper mechanism comprises a plate that is fixed to the respective slitter mechanism adjacent to the cutting disc.

15 22. The apparatus according to claim 19, wherein the plurality of the slitter mechanisms are configured to cut the core substrate and to space apart the core sections prior to a webbing material being mounted to the core sections.

20 23. The apparatus according to claim 19, wherein the slitter mechanisms are moveable between the cutting position and a gripper engagement position wherein the gripper mechanisms engage the core sections.

25 24. The apparatus according to claim 19, wherein the gripper mechanisms include friction enhancing members on a surface of the gripper mechanism that engages the core sections.

30 25. The apparatus according to claim 19, wherein the gripper mechanisms are configured to hold the core section in the spaced apart orientation.

35 26. An apparatus for forming paper roll products, comprising:
 a mandrel having a longitudinal axis; and
 a core slitter assembly positioned adjacent the mandrel, the core slitter assembly having a plurality of slitter mechanisms, each slitter mechanism including a cutting disc and a gripper mechanism, and the slitter mechanisms are mounted to be moveable between a non-cutting position wherein the slitter mechanisms are away from the mandrel, and a cutting position wherein the slitter mechanisms are positioned to cut a core

substrate disposed on the mandrel into a plurality of core sections, and the plurality of
slitter mechanisms are mounted to be moveable relative to the mandrel in a direction
parallel to the longitudinal axis to space apart the core sections along the longitudinal axis;

5 wherein the slitter mechanisms are moveable between the cutting position and
a gripper engagement position wherein the gripper mechanisms engage the core sections.

27. The apparatus according to claim 26, wherein the gripper mechanism
comprises a plate of flexible material.

10 28. The apparatus according to claim 26, wherein the gripper mechanism
comprises a plate extending distally beyond a distal end of the cutting disc.

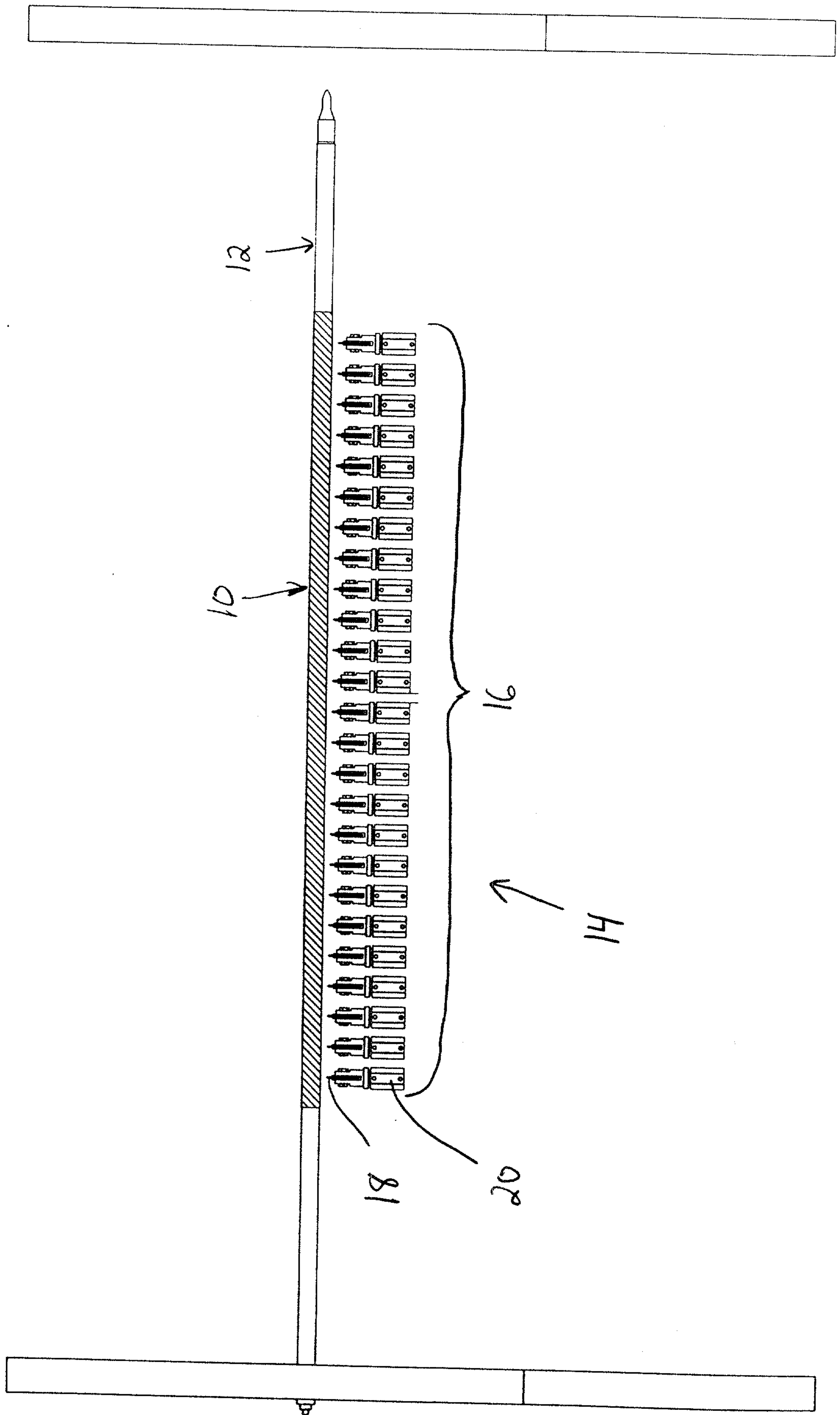
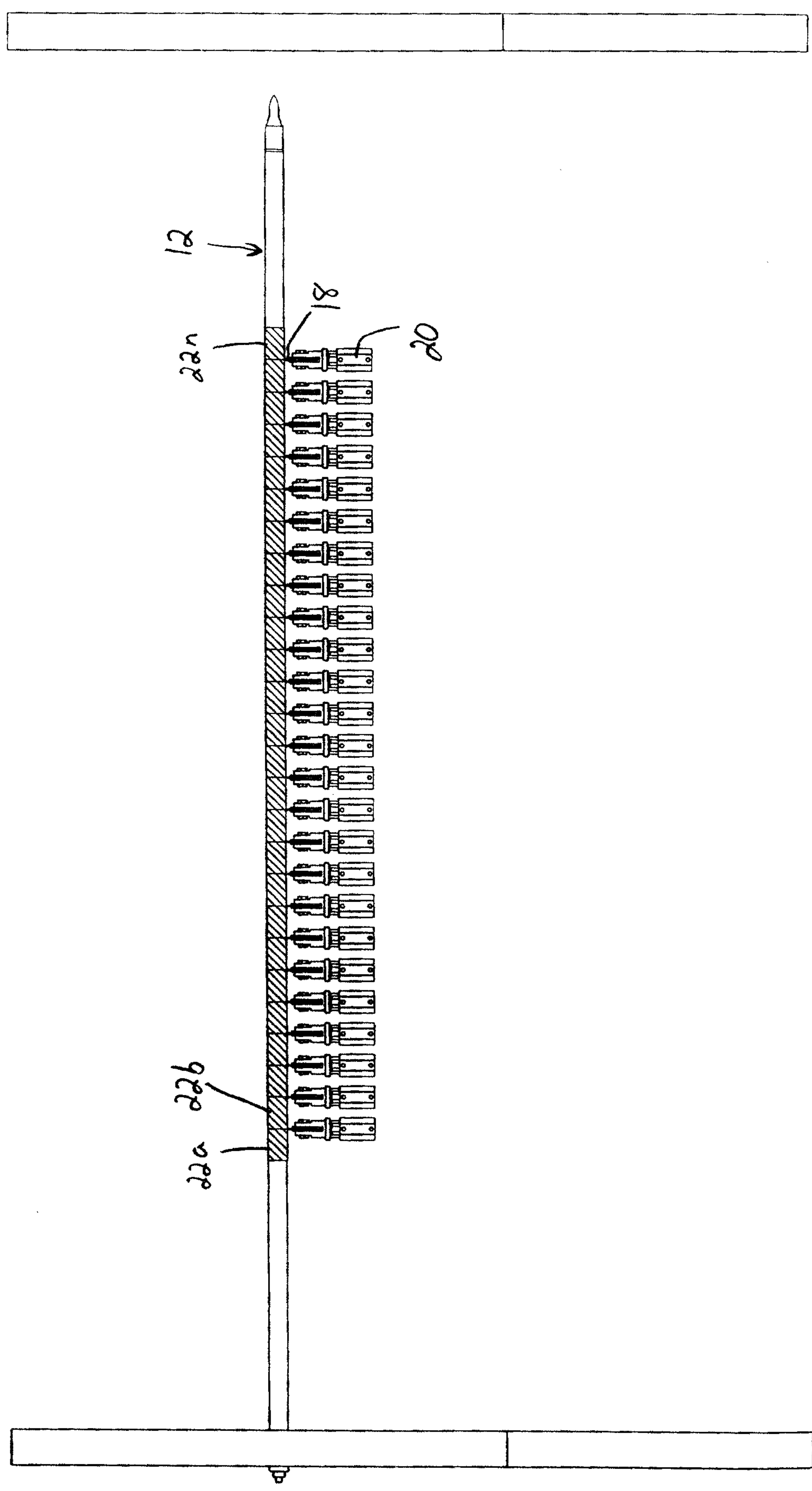

FIG. 1A

FIG. 1B



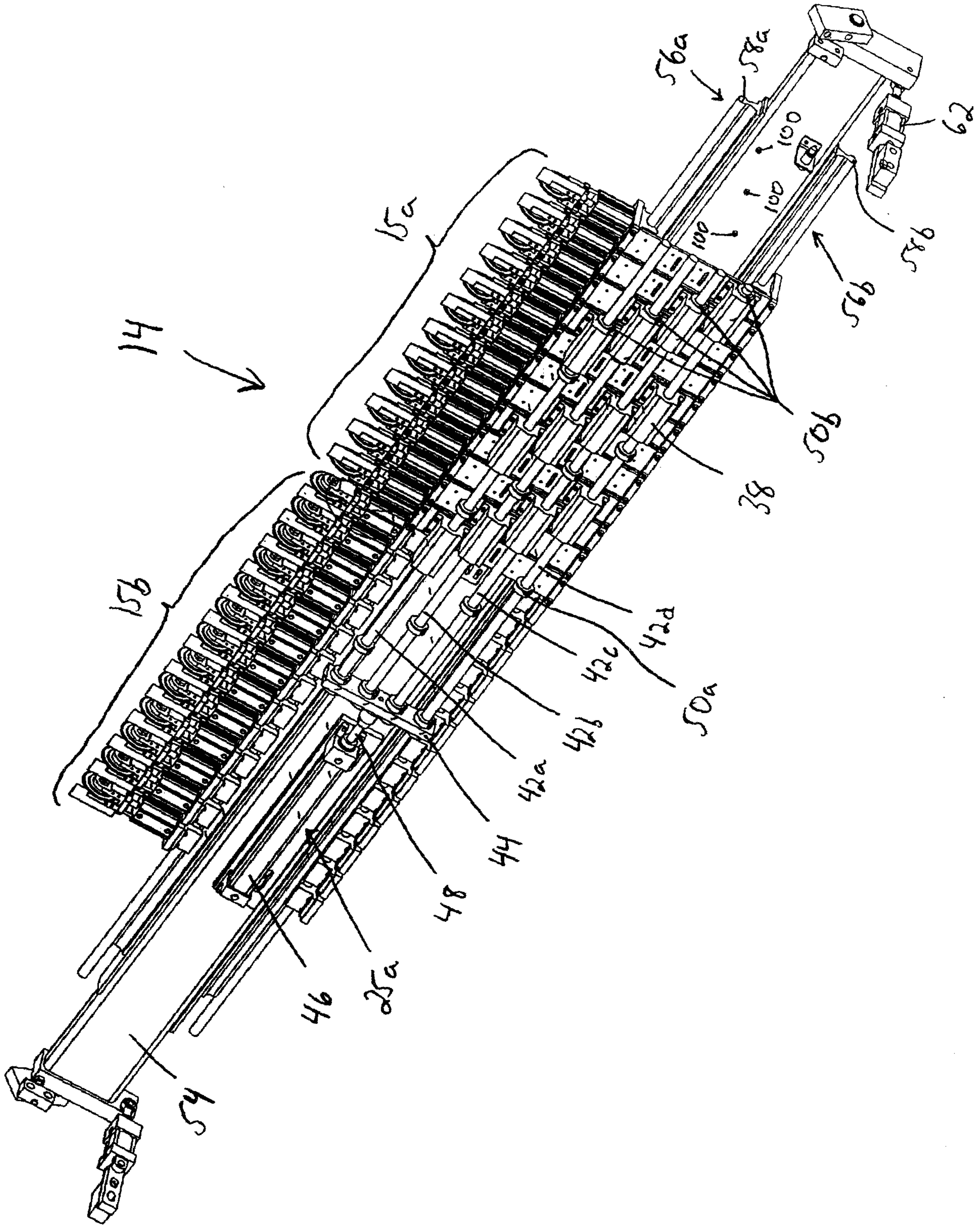

FIG. 2A

FIG. 28

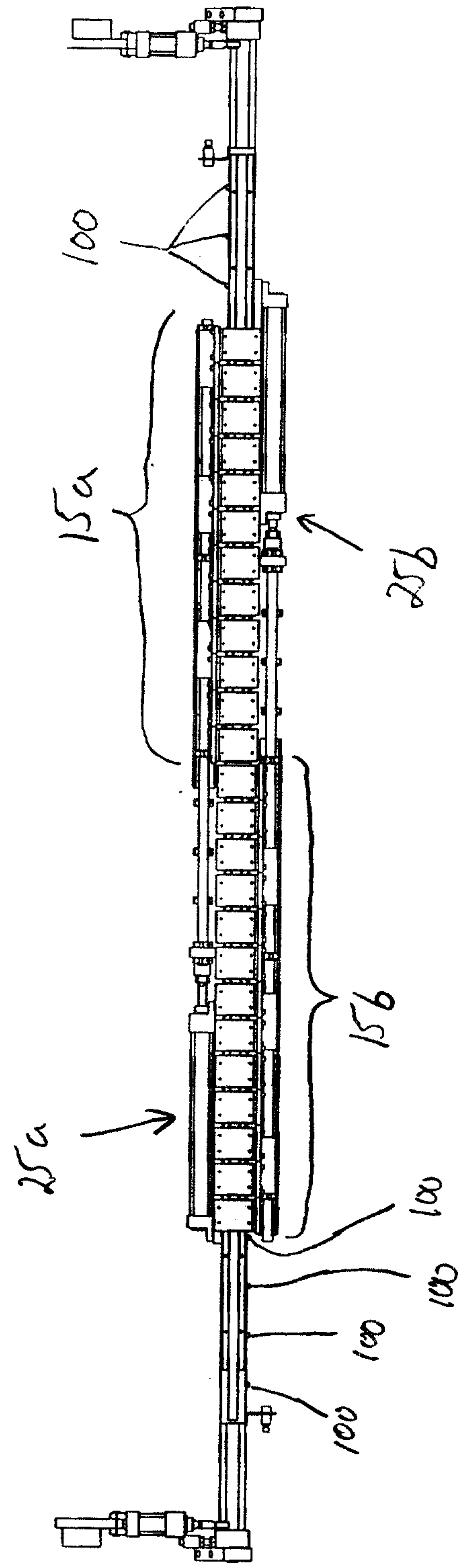

FIG. 3

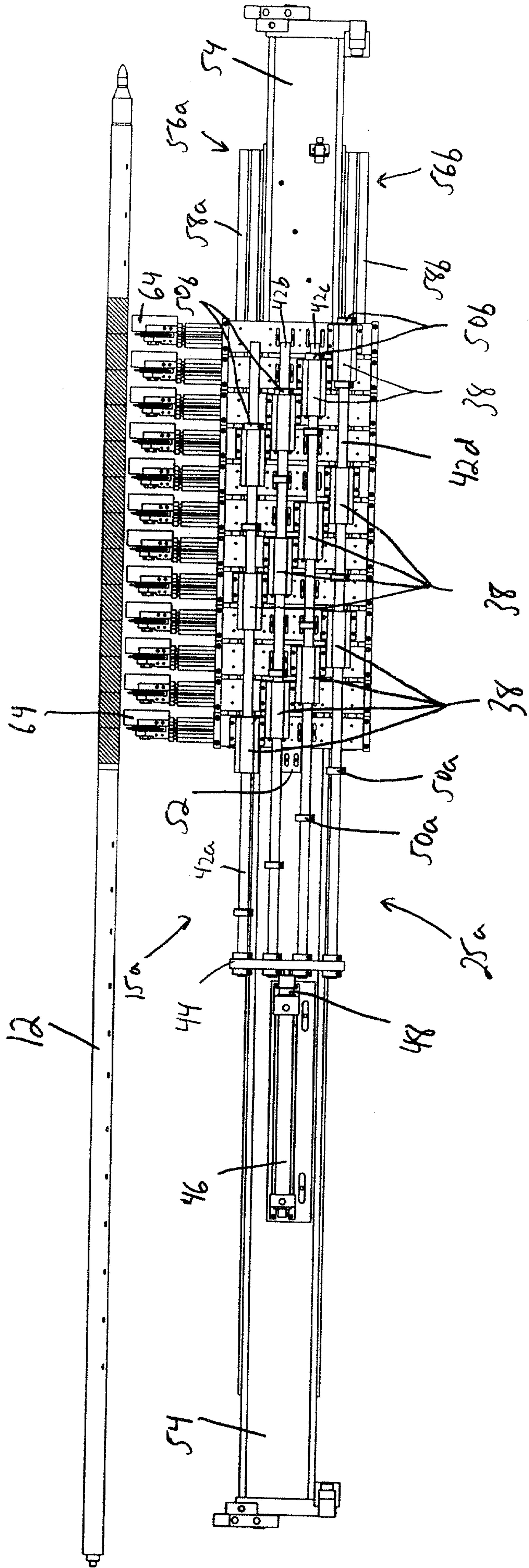

FIG. 4

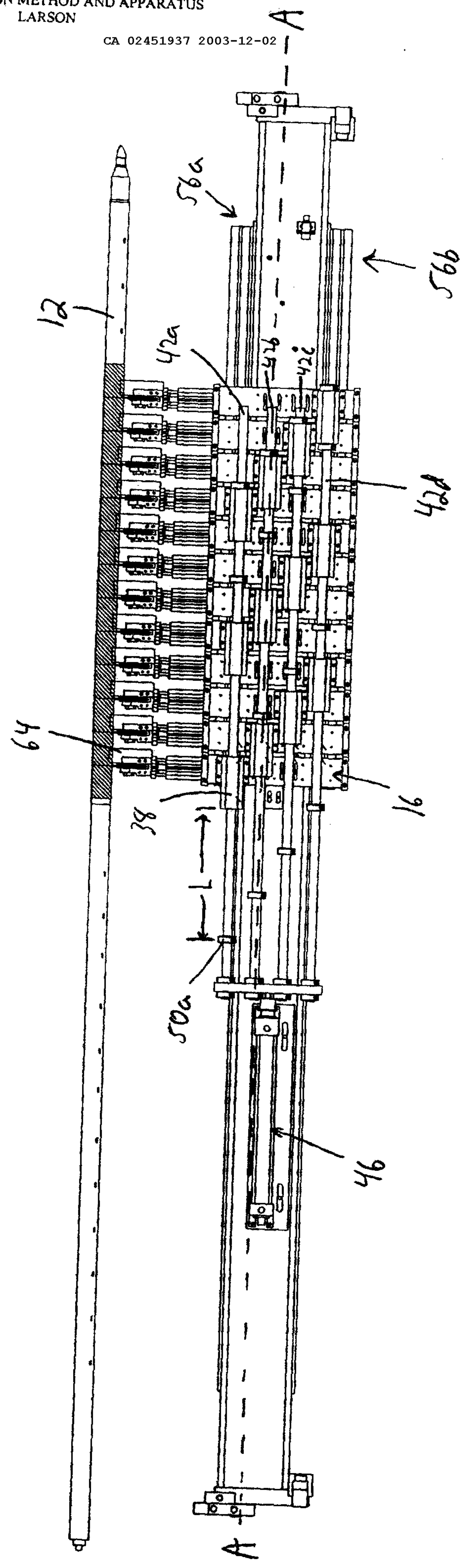

FIG. 5

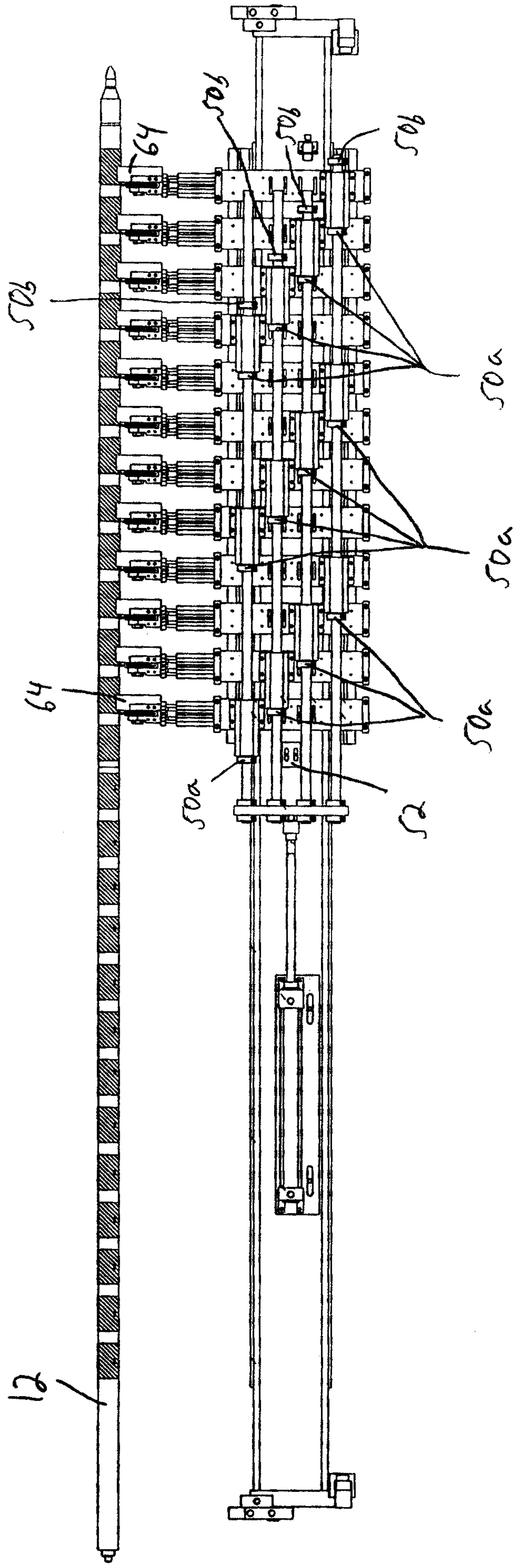

FIG. 6

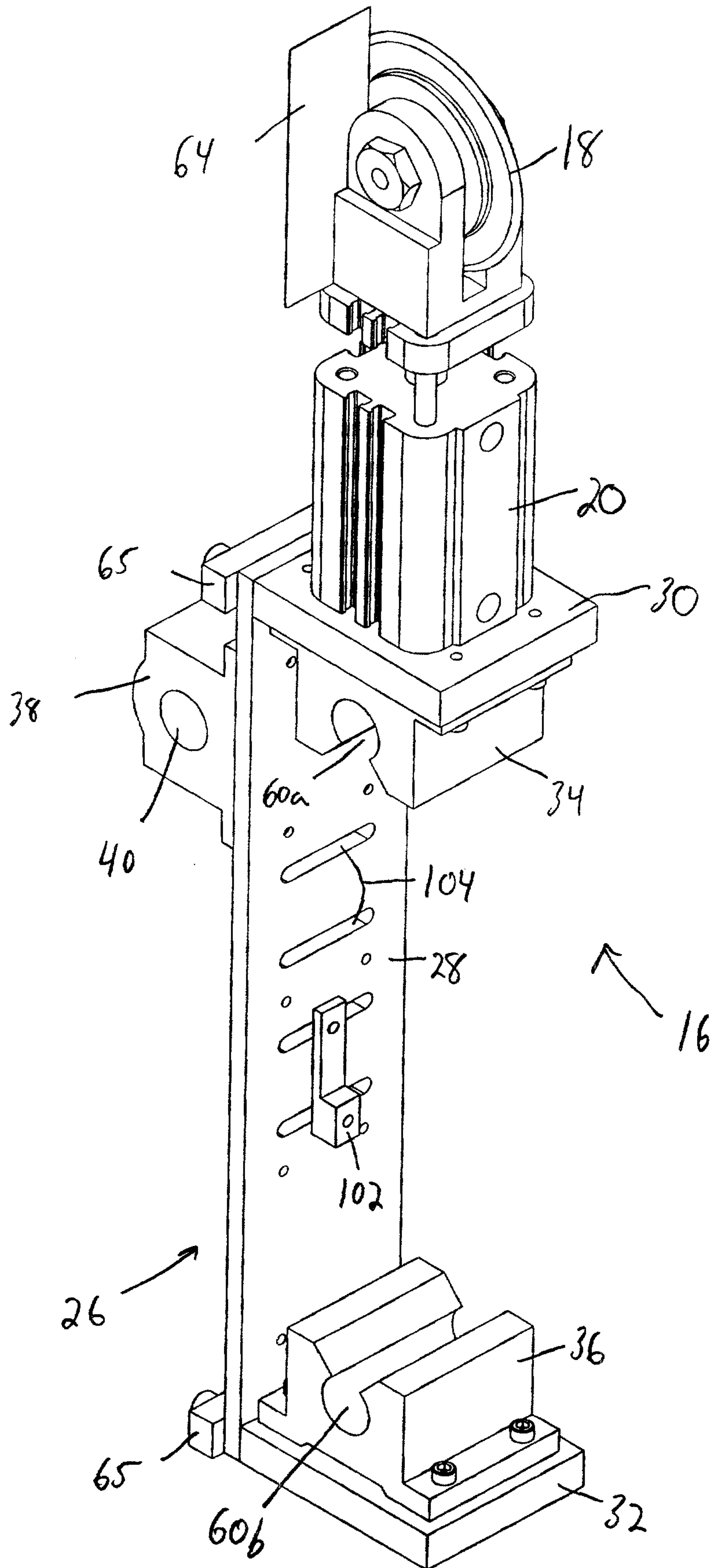

FIG. 7

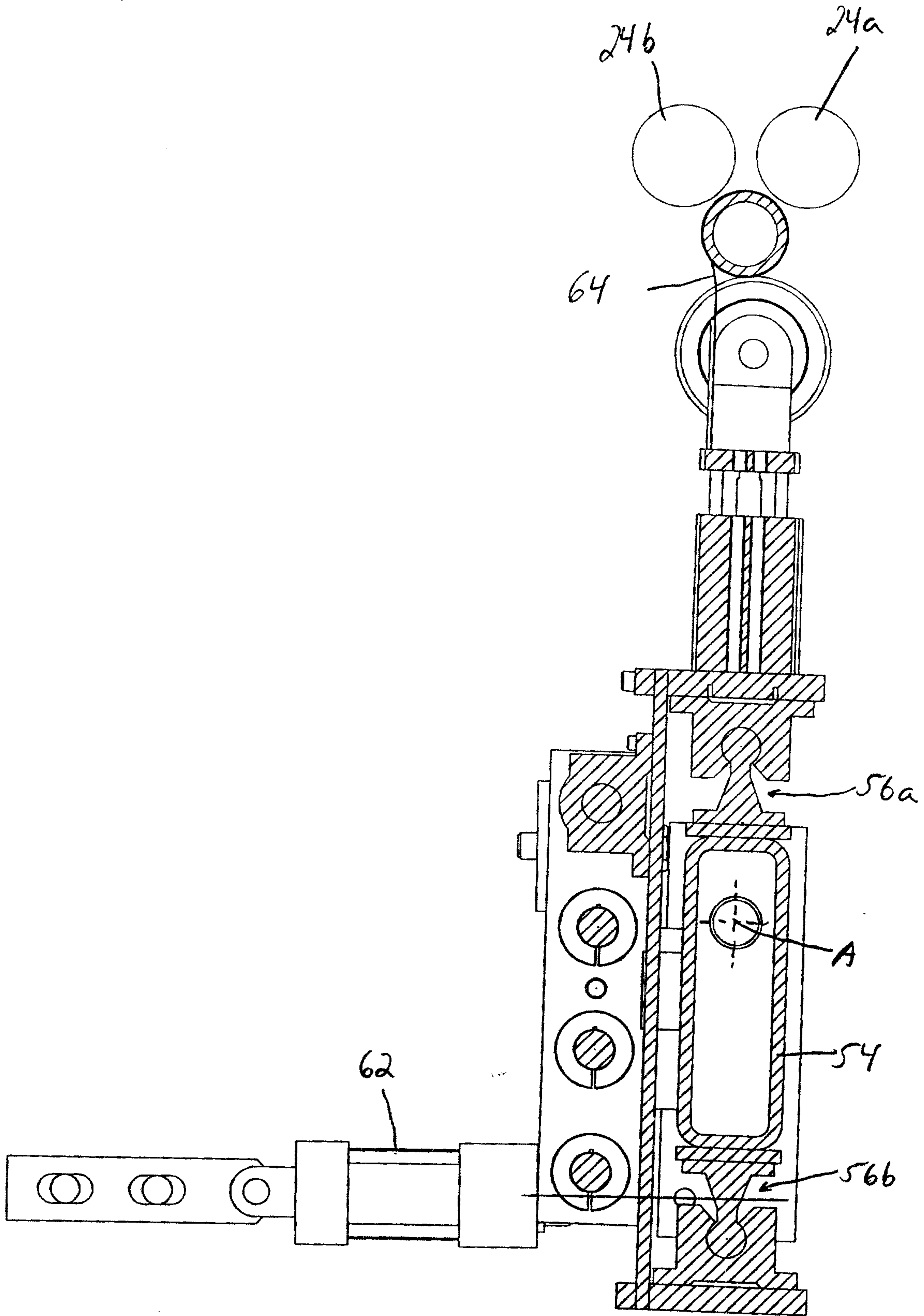

FIG. 8

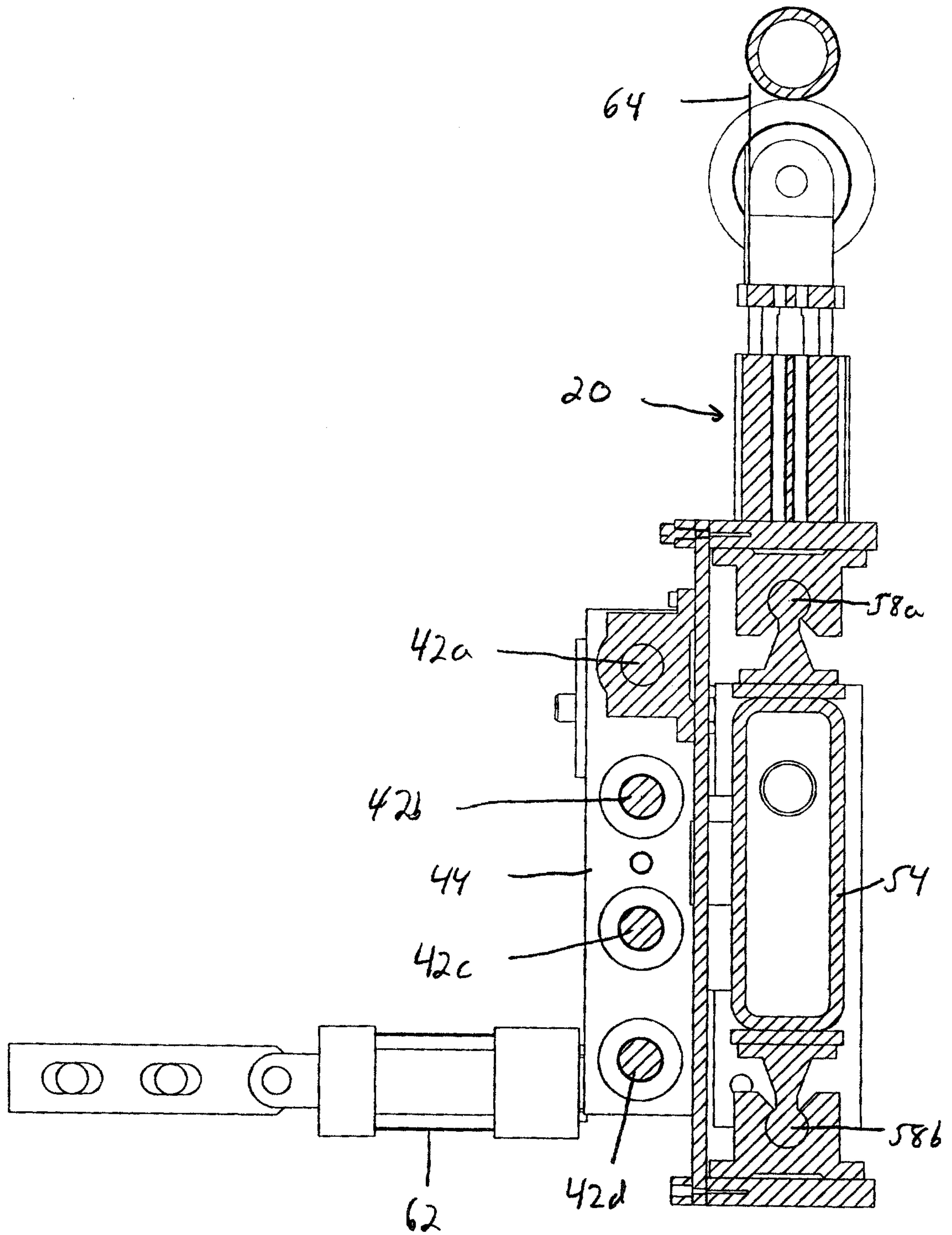

FIG. 9

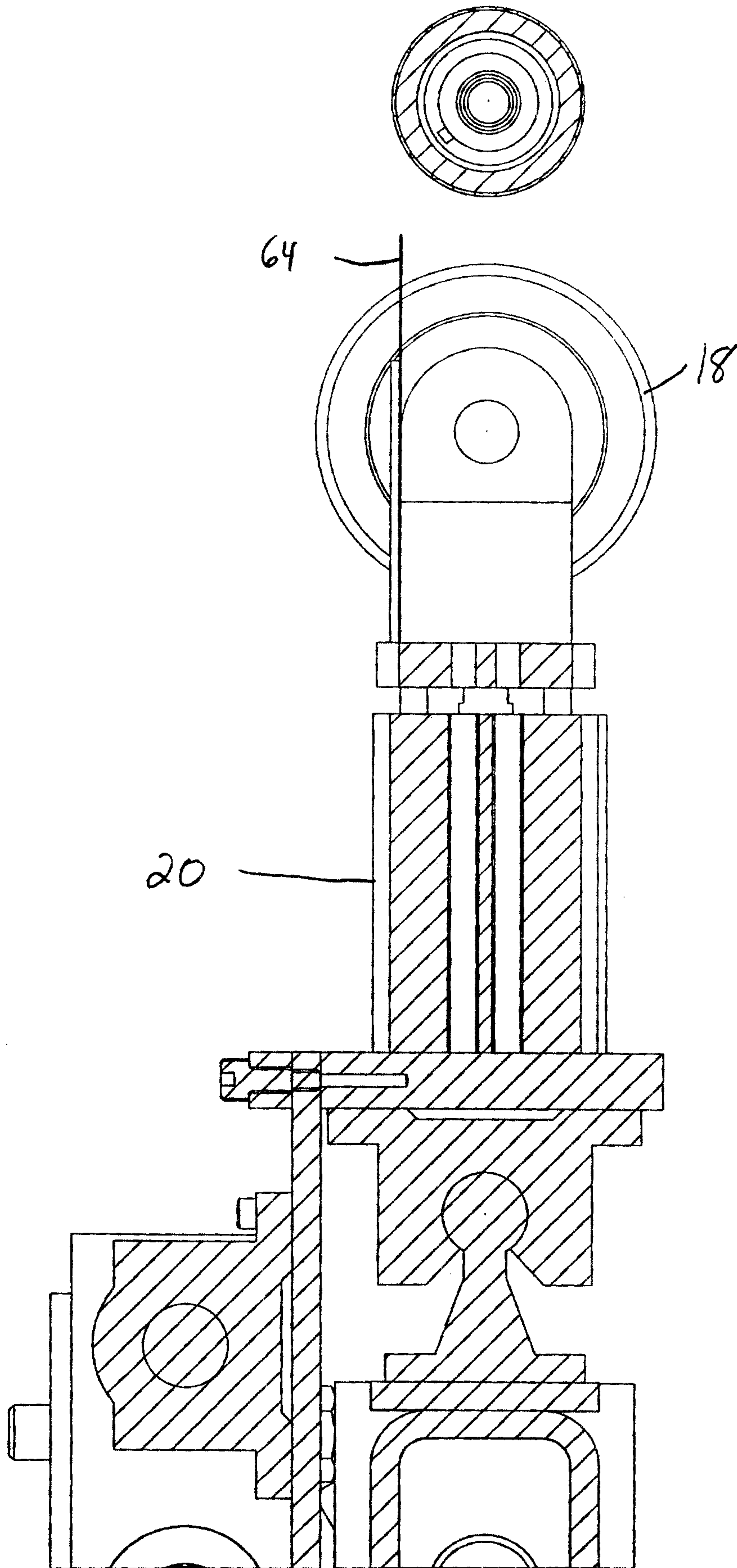

FIG. 10

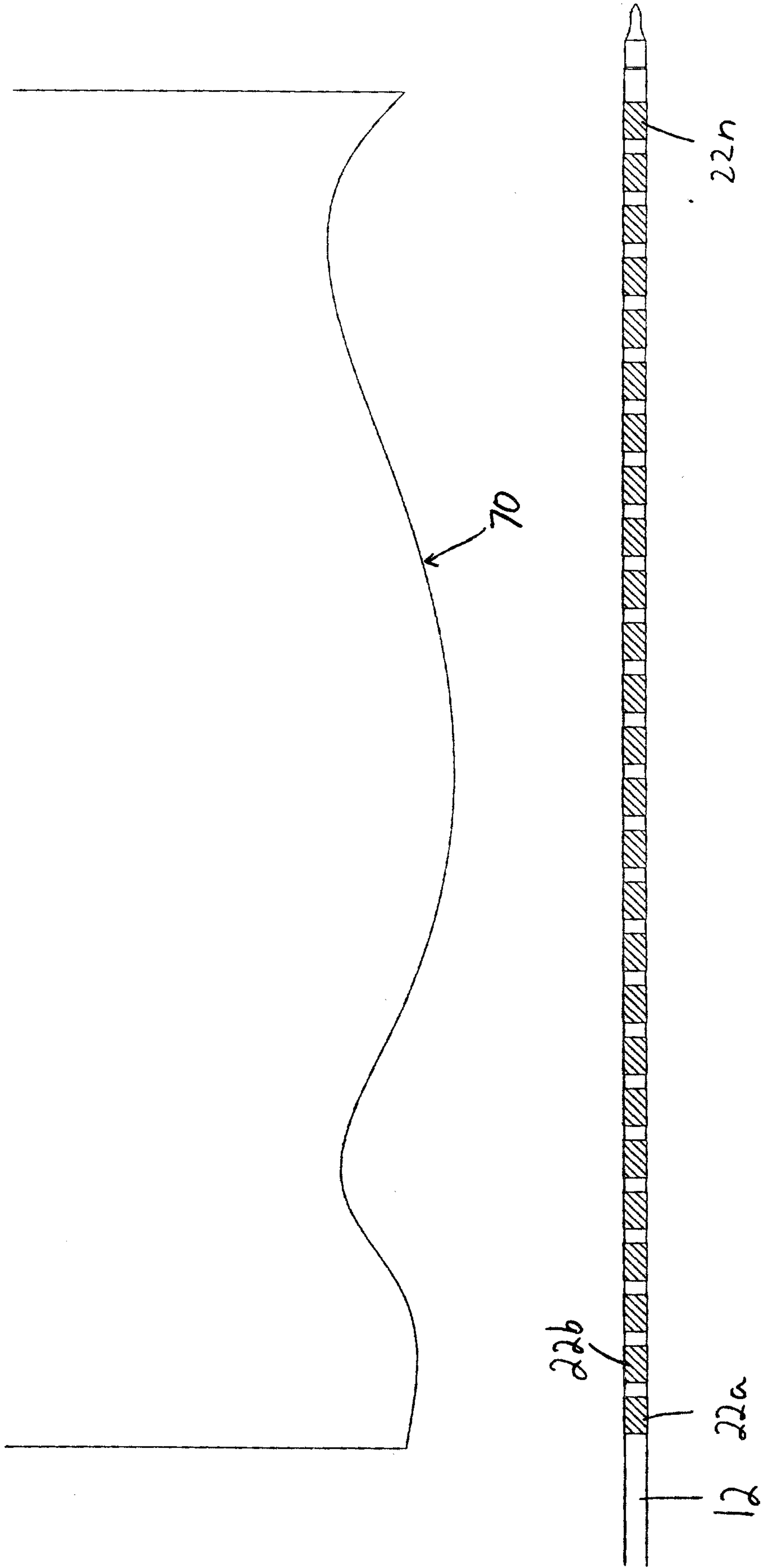

FIG. 11

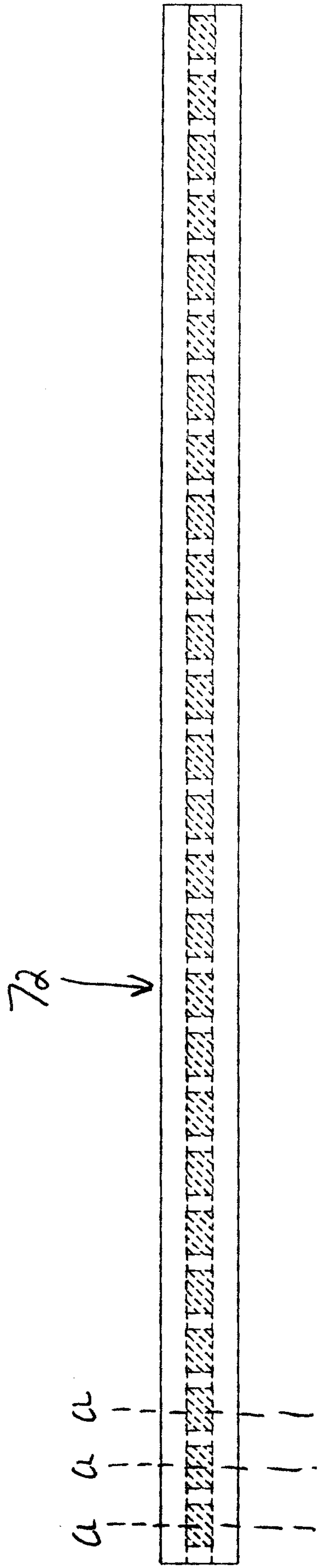

FIG. 12

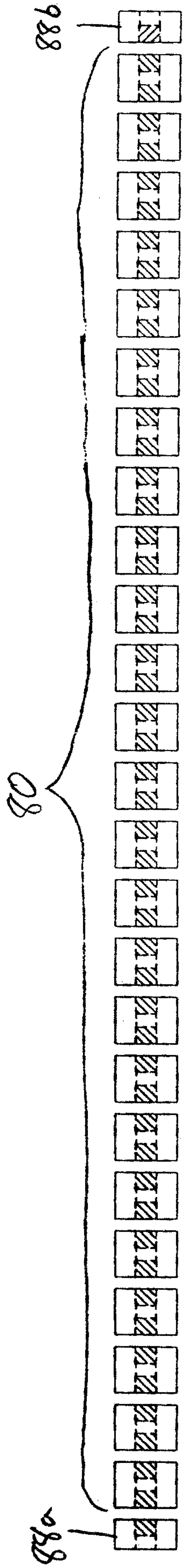

FIG. 13

