

- [54] SAFETY LOCK ASSEMBLAGE FOR MOVABLE ITEMS
- [75] Inventor: Daniel J. Foote, Wauwatosa, Wis.
- [73] Assignee: Master Lock Company, Milwaukee, Wis.
- [22] Filed: Oct. 22, 1971
- [21] Appl. No.: 191,716
- [52] U.S. Cl. .... 70/58, 70/49, 70/55, 70/232, 70/DIG. 57
- [51] Int. Cl. .... E05b 73/00
- [58] Field of Search ..... 70/30, 49, 55, 56, 70/57, 58, 180, 212, DIG. 56, DIG. 57; 292/148; 248/203; 211/4, 5

FOREIGN PATENTS OR APPLICATIONS

4,935	0/1885	Great Britain .....	70/34
959,271	5/1964	Great Britain .....	70/57

Primary Examiner—Albert G. Craig, Jr.  
Attorney—Curtis B. Morsell, Sr.

[57] ABSTRACT

To prevent the theft or unauthorized removal or displacement of a movable property item there is provided an elongated flexible connection whose intermediate portion is looped about or secured to or through a portion of the item to be protected. A convenient support in the vicinity of the movable item has secured thereto a box and within the box is the body of a lock which covers and renders inaccessible the box securing means. The opposite ends of the elongated flexible connection are adjustably carried by the lock in a manner so that one or both of said ends may be released upon unlocking the lock. When the latter is locked it cannot be removed from the anchored box nor can the flexible connection be released from the lock or the property item to which it extends.

5 Claims, 6 Drawing Figures

- [56] **References Cited**
- UNITED STATES PATENTS**
- 949,809 2/1910 Sheen ..... 70/62
- 1,792,403 2/1931 Stone ..... 70/49 X
- 3,605,458 9/1971 Best ..... 70/38 B
- 51,524 12/1865 Trimble ..... 70/59
- 3,559,429 2/1971 Hermann ..... 70/85
- 3,606,423 9/1971 McCarthy ..... 292/148

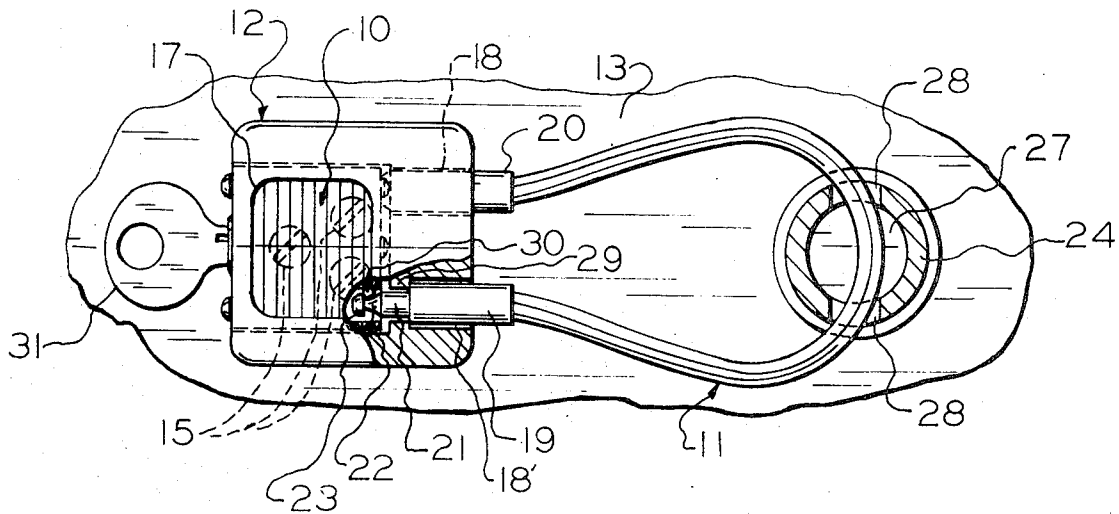

FIG - 1

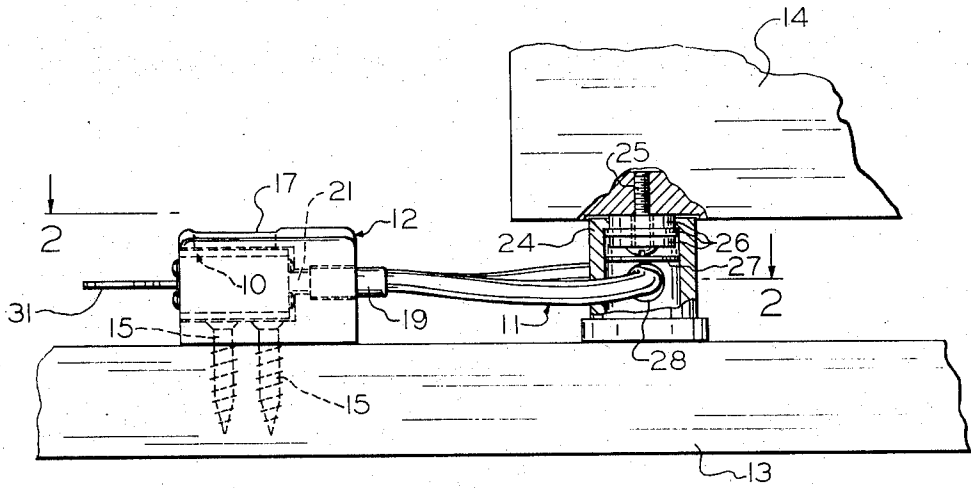

FIG - 2

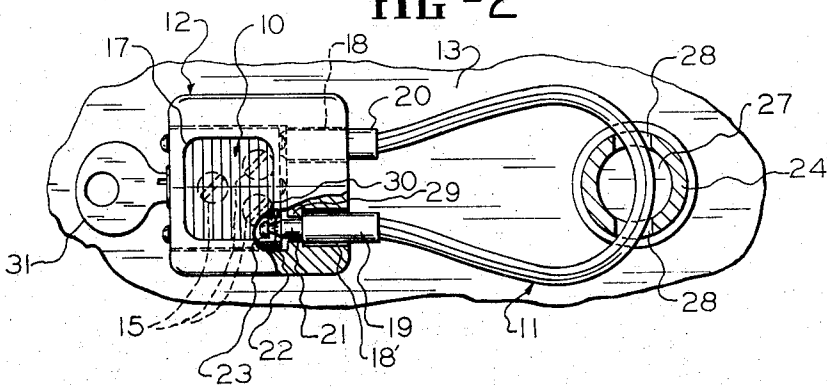

FIG - 3

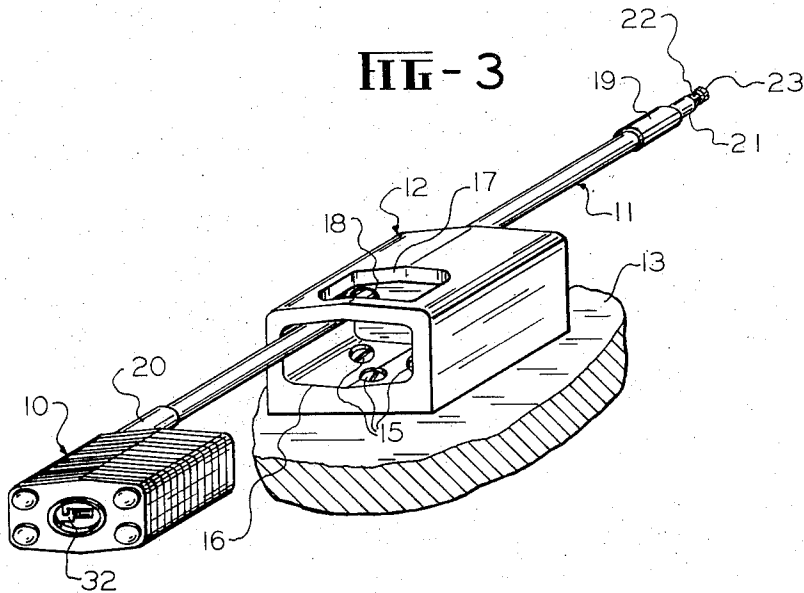

FIG - 4

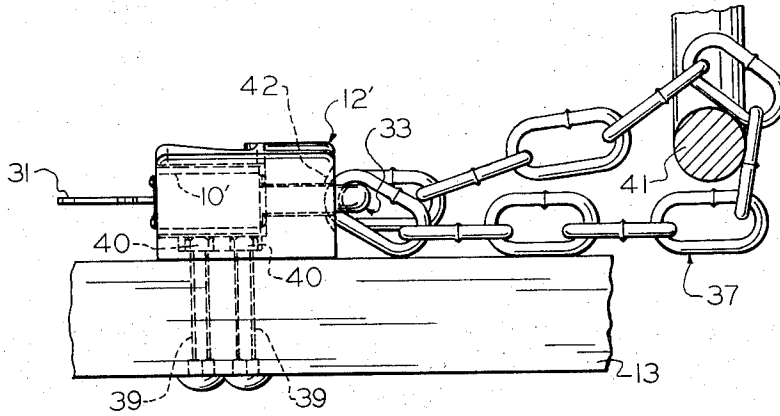

FIG - 5

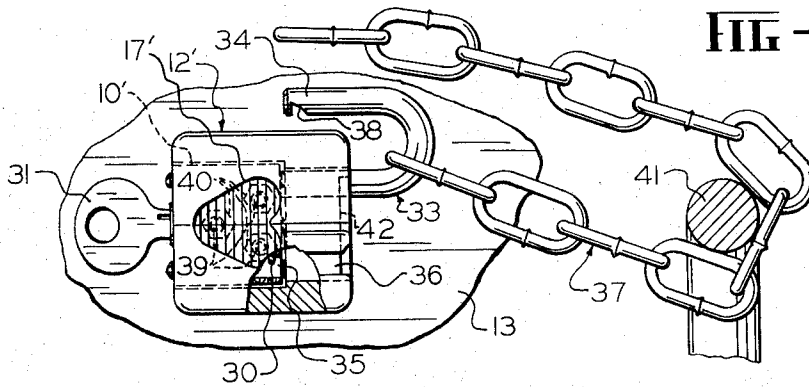
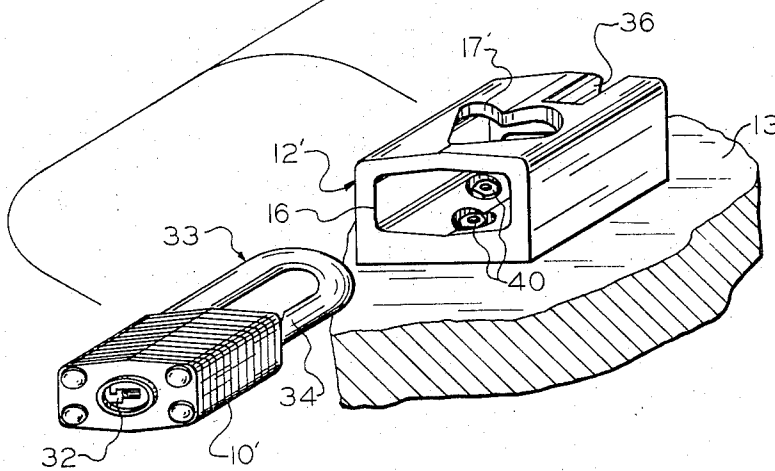

FIG - 6



## SAFETY LOCK ASSEMBLAGE FOR MOVABLE ITEMS

### BACKGROUND OF THE INVENTION AND SUMMARY THEREOF

Innumerable valuable movable items and equipment are subject to pilferage. This includes various office equipment items such as typewriters, adding machines, copiers, etc., as well as items with which hotel and motel rooms are equipped such as radios, television sets and lamps; and garage or shed stored appliances and equipment; and pier-docked boats, boat mounted motors and the like.

It is, therefore, a primary object of the present invention to provide a safety lock assemblage which cannot be unauthorizedly detached from its mounting and which can be extended to and lockably engaged with any of the class of movable items above-mentioned to render the same pilfer-proof while still permitting said items to be moved or shifted within a limited range.

A further object of the invention is to provide a safety lock assemblage of the character described which is portable, which can be easily mounted against undesired removal on a suitable supporting surface on which the item to be protected is stationed, or adjacent thereto, which can be easily applied to or authorizedly removed from the item to be protected, and which is simple to operate.

A further object of the invention is to provide a safety lock assemblage in which a support mounted lock unit carries an outwardly extended looped flexible connection directed to and intermediately engaged with the item to be protected, with the ends of said flexible connection being lockably carried by the lock unit.

Still further objects of the invention are to provide a safety lock assemblage for movable items which is strong and durable and provides maximum protection, which is relatively inexpensive, and which is well adapted for its intended purposes.

Prior art of which applicant is familiar include the U.S. Pats. to Schaefer, No. 3,211,408; Sager et al. No. 1,274,203; Nagel No. 3,585,823; and applicant's co-pending application Ser. No. 13,395, filed Feb. 24, 1970, now U.S. Pat. No. 3,664,163 dated May 23, 1972. The prior art does not teach the utilization of a box anchored to a support and housing a padlock body which covers and renders inaccessible the means which fasten the box to its support, with a flexible connection extending from a portion of the padlock to the item to be protected, the arrangement further being such that when the lock is released the flexible connection may be disengaged from the item it protects and the padlock body may only then be removed from its anchored box.

### BRIEF DESCRIPTION OF THE DRAWINGS

In the drawings wherein the same reference characters designate the same or similar parts in all of the views:

FIG. 1 is a fragmentary side view of the support on which a movable item to be protected is stationed with one form of the improved safety lock assemblage being anchored to a surface of the support adjacent the item and lockably securing the latter by an elongated flexible connection threaded through a special leg with which the item is equipped, a portion of the protected item being broken away and in section as is the special leg therefor;

FIG. 2 is a horizontal sectional view taken approximately along line 2—2 of FIG. 1 with other portions broken away and in section;

FIG. 3 is an exploded end and side perspective view of the mounting box for the assemblage and its support with the padlock body removed from an open end of the box with one end portion of the elongated flexible connection released from the padlock body and disengaged from the protected item;

FIG. 4 is a view similar to FIG. 1 only showing a modified form of lock assemblage wherein the box houses a standard shackle padlock with the shackle engaging the links of a chain which is engaged with a portion of the item to be protected, the box being secured to the support by upwardly extended bolts;

FIG. 5 is a plan view of the showing in FIG. 4 with parts broken away and in section; and

FIG. 6 is an exploded perspective view of the support mounted box and shackle padlock of the alternative form of assemblage with the padlock removed from the open end of the box.

### DESCRIPTION OF THE PREFERRED EMBODIMENTS

Generally speaking, the improved safety lock assemblage includes a box anchored to a support and housing a padlock body which, when in place, covers and renders inaccessible the securing means for the box. The support carries a movable property item which is engaged by an intermediate portion of a looped elongated flexible connection whose ends are engaged by a portion of the padlock.

In the form of the invention shown in FIGS. 1-3 inclusive the assemblage utilizes a cable shackle padlock whose body is generally indicated by the numeral 10 with the numeral 11 designating the elongated cable shackle. A box, having openings in certain of its walls, is indicated generally by the numeral 12 and the same is mounted on a surface of a support 13 in proximity to a movable property item 14, by screws 15 which, in the form of the invention shown in FIGS. 1-3 inclusive, go through the bottom wall of the box and into the body of the support with the heads of the screws being covered and rendered inaccessible by the padlock body 10 when the latter is housed within the box, as in FIGS. 1 and 2. When the padlock body is in its housed, locked condition, engaging the freeable collared end portion 19 of the cable shackle 11, the padlock body cannot be removed from its box 12. Otherwise, it may be removed through an opening 16 in an end of the box to expose the heads of the screws 15 which can be engaged by a screwdriver inserted through an opening 17 in the top wall of the box 12. The end of said box, opposite the end containing the padlock entrance and removal opening 16, is formed with spaced-apart openings 18 and 18' through which the collared end portions 19 and 20 of the cable shackle 11 extend. The collared end 20 of the cable shackle 11 is permanently secured within the padlock body, as shown in FIGS. 2 and 3. The other collared end 19 of the cable shackle is freeable, and outwardly of the collar 19 then are reduced diameter portions 21 and 22 terminating in a head 23. With the assemblage in the condition shown in FIGS. 1 and 2 for property item securing purposes an intermediate portion of the cable shackle may be threaded through or wrapped around some convenient portion of the protected item 14.

Merely by way of illustration the movable item 14 may be a piece of office equipment such as a typewriter, adding machine, copier or the like. One of the standard legs or supports carried by the item may, and this is optional, be replaced by a special form of a cylindrical, tubular leg 24, best shown in FIG. 1 and held to the base of the property item 14 by a screw 25 whose shank, inwardly of its head, carries collars 26. Also, frictionally held within the hollow leg 24 to cover and render inaccessible to a tool, is a washer 27. Below said washer 27 the side walls of the leg 24 are formed with diametrically aligned openings 28 through which the cable shackle is threaded as shown in FIGS. 1 and 2. In the operative and installed condition of the safety lock assemblage the freeable end of the cable shackle is returned to the anchored box 12 and inserted into the box opening 18' whose inner end is shouldered, as at 29. The shouldered inner end of the collar or bushing 19 engaging the shoulder 29 will prevent outward withdrawal of the padlock body 10 through the box opening 16 when said freeable end of the cable shackle is locked within the padlock body by a reciprocal locking lever 30 projected into the grooved reduced portion 22 of said shackle end through the operation of internal lock body mechanism operated by the turning of a key 31 inserted into the lock body key slot 32 which is accessible through the box opening 16.

The locking lever mechanism housed within the padlock body 10 is essentially similar to that disclosed in the prior Foote U.S. Pat. No. 3,473,352 of Oct. 21, 1969. Also, in lieu of a key operated padlock the anchored box 12 may house the body of a permutation padlock of the general type shown in the prior Soref et al. U.S. Pat. No. 2,893,231 of July 7, 1959. In this event, the top wall of the anchored box 12 would have an opening therein of a size and shape to accommodate and render accessible the permutation lock dialing knob.

In the form of the invention shown in FIGS. 4-6 inclusive the padlock body 10' housed within the modified support-anchored box 12' has reciprocatably and swingably associated therewith a U-shaped, relatively short shackle 33 of rigid metal and having a notched leg 34 which, when unlocked and reciprocated out of its body or case opening 35 can be swung through a trough 36 provided therefor in the top and end wall of the box 12' to an open position, as shown in FIG. 5, permitting one or both end links of an elongated flexible connection in the form of a chain 37 to be engaged with or disengaged from the lock shackle 33. Again, the mechanism within the lock body which operates the locking lever 30 to engage it with or release it from the notch 38 in the freeable leg of the shackle is of the type disclosed in said prior Foote U.S. Pat. No. 3,473,352.

The box 12' in the modified form of the invention may be secured onto the surface of the support 13 in the manner shown in FIG. 1 or, elongated bolts 39 whose heads engage the underside of the support are directed upwardly through the support and the bottom of the box 12' and their threaded extremities carry nuts 40 preferably lodged within recesses therefor in the bottom of the box 12', all as shown in FIGS. 4, 5, and 6. Said nuts are inaccessible when the padlock body is secured within the box 12', but when the shackle 33 has been unlocked and the chain 37 disengaged therefrom the padlock may be removed from the box 12' through the opening 16 in its end, as in FIG. 6. Then,

tool access to the nuts 40 is possible through the specially formed opening 17' in the top of the box. When the box is to be mounted onto a support surface or removed therefrom the padlock must be removed from the box. As long as it is locked within the box access to the securing means for the latter is precluded, and this is an important safety factor, as in the principal form of the invention an intermediate extent of the elongated connection (a chain in FIGS. 4 and 5) is secured about some portion of the property item to be protected. As shown in FIGS. 4 and 5 the item may carry a rod or bar 41 or other ledge or the like about which the chain or elongated connection is looped. Both ends of the chain are secured onto the padlock shackle 33 and when the latter is locked within the padlock body the chain cannot be detached nor can it be unauthorizably removed from the item it is anchoring and protecting, although permitting a limited range of movement for the latter.

As is best shown in FIGS. 4 and 5 when the shackle is locked within the body 10' with the ends of the chain engaged on the shackle only a limited portion of said short shackle projects out of the box 12' and the partitions 42 therewithin. This results in a snug engagement for the end links of the chain. Consequently, if a tamperer should attempt to slide the padlock out of the box 12 contact of the shackle-engaged end links of the chain 37 with said internal box partitions 42 will prevent longitudinal withdrawal of the padlock from its box. The latter can only be accomplished after the chain ends have been disengaged from the shackle 33, with the shackle thereafter being closed in empty condition, as in FIG. 6.

#### SUMMARY

As was mentioned heretofore the padlock may be of any desired type and can incorporate an elongated cable shackle which then becomes the tether engaging a portion of the property item to be protected. Or, the padlock may have a standard shackle which engages the opposite ends of an elongated flexible connection which extends to and secures the property item.

With the padlock body being locked within the support-anchored box 12 or 12' and having the elongated flexible connection intermediately engaged with a portion of the property item with the ends of the flexible connection held by the padlock in the locked condition of the latter, the protected property item is only susceptible of being moved through a very limited range and it cannot be taken away from the support and pilfered. With the padlock body locked within its box, through the means previously described it is not removable through the box opening 16 and will cover the box securing means 15 or 39, rendering the same inaccessible to a tamperer. Double protection is afforded. The elongated flexible connection cannot, under the conditions stated, be disengaged from the protected item, nor can the box and padlock portions of the assemblage be surreptitiously removed from the support. However, by unlocking the padlock one or both ends of the elongated flexible connection can be disengaged from the padlock body for disconnection relative to the property item. By removing the padlock body from its box, as in FIGS. 3 and 6, access to the box securing means can be gained whereby the box may be removed from the support for use of the assemblage in a different location, if desired, for the protection of some other property item.

As previously indicated the improved safety lock assemblage is susceptible of usage for the protection of vast varieties of movable property items. In addition to its use for office equipment and accessories in hotel rooms and public places, the assemblage can be used to protect garage and shed stored items or it can be used on boats and piers for safeguarding marine equipment and/or boat accessories, motors, oars, etc. The assemblage is free of manufacturing complications, is easy to install, engage with a property item and operate, is portable and susceptible of easy re-location, is strong, durable and effective, and is furthermore well adapted for the purposes described.

What is claimed is:

1. In combination, a support; a box mounted on the support and having openings in certain of its walls; securing means between the support and the box and terminating therewithin; a lock having a body lockably housed within said box and rendering said securing means inaccessible; said lock body having an element of a lock mechanism actuator accessible through one of said box wall openings; and a shackle having its end portions lockably securable to the lock body, there being contacting shoulders between a portion of a secured end of the shackle and said box preventing the removal of the lock body from the box when said body is in its locked condition within the box.

2. The combination recited in claim 1 wherein one end portion of the shackle is releasable from the padlock body when unlocked and is extended through one of said box openings, the last-mentioned portion of the shackle and the box having cooperating means for preventing sliding movement of the lock body relative to

the box when the shackle is locked to the lock body.

3. The combination recited in claim 1 wherein the shackle includes an elongated flexible connection which extends to an item to be protected, the latter carrying an apertured protuberance through which an intermediate portion of the flexible connection is threaded, there being securing means between an inner portion of said protuberance and the item to be protected rendered inaccessible by the threaded through portion of the elongated flexible connection.

4. In combination, a support; a box-like enclosure mounted on the support and having a base with walls along all marginal portions of the base extending perpendicularly to the base, there being openings in some of the perpendicular walls; securing means between the support and the box base terminating within said box-like enclosure; and a lock body lockably housed within said enclosure in covering relation to said securing means to render the latter inaccessible; said lock body having an element of a lock mechanism accessible through one of said enclosure wall openings, and the lock body, when unlocked, being movable longitudinally of the enclosure in a plane parallel to the base of the latter into and out of the box-like enclosure through the same wall opening which provides accessibility to the lock mechanism actuator.

5. The combination recited in claim 4 wherein the box-like enclosure is six-sided and there are means within the enclosure for preventing movement of the lock body out of the enclosure when the lock body is locked.

\* \* \* \* \*

35

40

45

50

55

60

65