

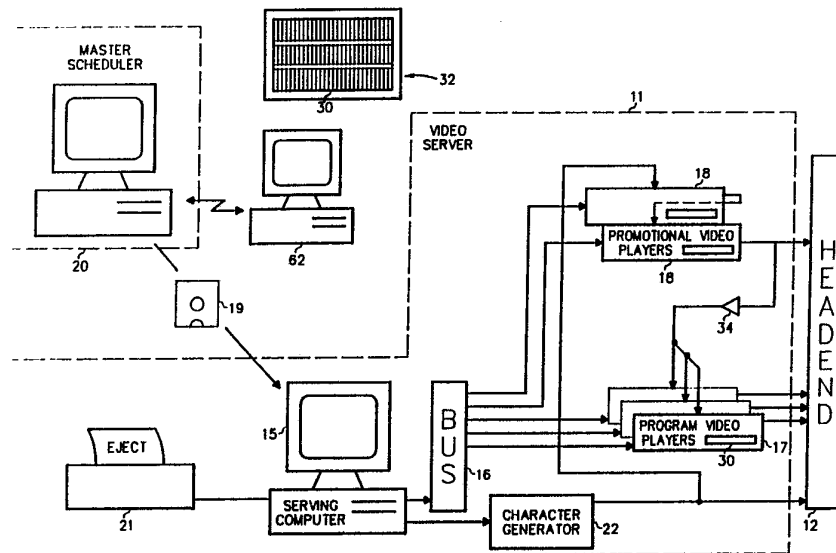

## INTERNATIONAL APPLICATION PUBLISHED UNDER THE PATENT COOPERATION TREATY (PCT)

<p>(51) International Patent Classification <sup>5</sup> : <b>H04H 1/02, H04N 7/167</b></p>	<p><b>A1</b></p>	<p>(11) International Publication Number: <b>WO 92/11713</b></p> <p>(43) International Publication Date: <b>9 July 1992 (09.07.92)</b></p>
<p>(21) International Application Number: <b>PCT/US91/09446</b></p> <p>(22) International Filing Date: <b>16 December 1991 (16.12.91)</b></p> <p>(30) Priority data: <b>633,637</b>                      <b>21 December 1990 (21.12.90)</b>    <b>US</b></p> <p>(71) Applicants: <b>GTE SERVICE CORPORATION [US/US];</b> <b>P.O. Box 152092, 600 Hidden Ridge Drive, Irving, TX</b> <b>75015-2092 (US). GTE LABORATORIES INCORPORATED [US/US];</b> <b>1209 Orange Street, Wilmington, DE</b> <b>19801 (US).</b></p> <p>(72) Inventors: <b>GILLETTE, Thomas, F. ; 495 S. Cedar Brook</b> <b>Road, Boulder, CO 80304 (US). WALKER, Stephen, S. ;</b> <b>117 Kelleher Road, Marlborough, MA 01752 (US). CAL-</b> <b>ABY, Lauren, F. ; 8111 Aviation Circle #202, Hunting-</b> <b>ton Beach, CA 92646 (US). SEIBEL, David, E. ; 4902</b> <b>Eversham Court, Colleyville, TX 76034 (US).</b></p>		<p>(74) Agent: <b>YEO, J., Stephen; GTE Service Corporation, 40</b> <b>Sylvan Road MS#31, Waltham, MA 02254 (US).</b></p> <p>(81) Designated States: <b>AT (European patent), BE (European</b> <b>patent), CA, CH (European patent), DE (European pa-</b> <b>tent), DK (European patent), ES (European patent), FR</b> <b>(European patent), GB (European patent), GR (Euro-</b> <b>pean patent), IT (European patent), JP, LU (European</b> <b>patent), MC (European patent), NL (European patent),</b> <b>SE (European patent).</b></p> <p><b>Published</b> <i>With international search report.</i></p>

## (54) Title: METHOD FOR PROVIDING VIDEO PROGRAMMING NEARLY ON DEMAND



## (57) Abstract

A method for providing video programming in a nearly on demand basis is disclosed. A video network (10) includes a video server (11) that operates several video recorders (17) to simultaneously exhibit video performances or programs on a plurality of channels. The video server (11) is controlled in real time in accordance with data presented to it in an exhibition plan (19). The exhibition plan (19) calls for two or more channels to show the same program on a time offset basis. Due to the offset in exhibiting a given program, a subscriber may view a program at any time, from the beginning of a program, by waiting for a period of time that is no longer than the offset.

**FOR THE PURPOSES OF INFORMATION ONLY**

Codes used to identify States party to the PCT on the front pages of pamphlets publishing international applications under the PCT.

AT	Austria	ES	Spain	MG	Madagascar
AU	Australia	FI	Finland	ML	Mali
BB	Barbados	FR	France	MN	Mongolia
BE	Belgium	GA	Gabon	MR	Mauritania
BF	Burkina Faso	GB	United Kingdom	MW	Malawi
BG	Bulgaria	GN	Guinea	NL	Netherlands
BJ	Benin	GR	Greece	NO	Norway
BR	Brazil	HU	Hungary	PL	Poland
CA	Canada	IT	Italy	RO	Romania
CF	Central African Republic	JP	Japan	SD	Sudan
CG	Congo	KP	Democratic People's Republic of Korea	SE	Sweden
CH	Switzerland	KR	Republic of Korea	SN	Senegal
CI	Côte d'Ivoire	LI	Liechtenstein	SU <sup>+</sup>	Soviet Union
CM	Cameroon	LK	Sri Lanka	TD	Chad
CS	Czechoslovakia	LU	Luxembourg	TG	Togo
DE*	Germany	MC	Monaco	US	United States of America
DK	Denmark				

+ Any designation of "SU" has effect in the Russian Federation. It is not yet known whether any such designation has effect in other States of the former Soviet Union.

METHOD FOR PROVIDING VIDEO PROGRAMMING NEARLY ON DEMANDTechnical Field

The present invention relates generally to methods  
5 for providing video programming to a multiplicity of  
network subscribers. Specifically, the present invention  
relates to methods for operating a video network which  
supplies pay-per-view video programming to subscribers in  
a nearly on demand basis.

10

Background of the Invention

Video and audio broadcasters engage in performing or  
otherwise broadcasting audio and visual productions or  
programs. Typically, such performances are provided to  
15 the broadcasters on magnetic and optical recording media,  
such as video and audio disks and tapes, over satellite or  
network feeds, from live performances, and the like. The  
broadcasters rebroadcast these performances over their  
networks. Each broadcast may be considered an exhibition  
20 of the performance.

Various examples of networks, such as cable TV  
networks, operated by broadcasters are known to those  
skilled in the art. Such networks provide occasional  
programming on a pay-per-view (PPV) basis. Broadcasters  
25 would like to increase the quantity of pay-per-view  
programming because such programming may help them reduce  
the risks associated with licensing certain high-priced  
performances for exhibition. Increased pay-per-view  
programming would also provide a more fair basis for  
30 charging subscribers for the programming services that are  
delivered to their premises. In other words, subscribers  
would be able to pay a fair price for only that  
programming that they actually view rather than pay  
averaged prices for a variety of programming, much of  
35 which they do not actually view.

-2-

One impediment to providing more extensive PPV programming has been the cumbersome techniques used in ordering the PPV services. Another impediment to providing more extensive PPV programming has been the lack  
5 of an ability to have programming available when a subscriber wishes to view it. It is common knowledge that viewers prefer to make programming selections on impulse. In other words, viewers tend not to think ahead about the programming that they may want to view at a later time.  
10 They prefer not to commit themselves to viewing a particular program at a particular future interval in time but rather to decide on impulse that they want to view some sort of programming at the present time.

15 The present invention is carried out in one form by a method of providing video programs to subscribers via a transmission system that has the capacity of transmitting a plurality of video channels. The method calls for storing the video programs in a controllable video player  
20 system. The video player system is controlled in accordance with a predetermined schedule and in a manner that causes the video programs to be applied at specified times to specified channels of the transmission system. The schedule instructs the video player system to be  
25 controlled so that at least one selected video program is simultaneously applied to a plurality of channels. The respective starting times of the selected video program on the respective plurality of channels are staggered by time intervals of a relatively short period in relation to the  
30 run-time of the selected video program. The video program on the selected channels is processed in a manner that renders the program on the channels substantially unintelligible. The selected channels are broadcast to subscribers via the transmission system. When subscribers  
35 request to view the video program, the request is processed. In response to a request from a subscriber,

the video program is rendered substantially intelligible to the subscriber on an appropriate one of the plurality of channels to which the selected video program is simultaneously applied.

5

#### Brief Description of Drawings

The details of the invention will be described in connection with the accompanying drawing wherein like reference numbers refer to similar items throughout the FIGURES, and in which:

FIGURE 1 shows a schematic representation of a system for distributing video programming, including a video server, in accordance with a preferred embodiment of the present invention;

FIGURE 2 shows a block diagram of a video server configured in accordance with the preferred embodiment of the present invention;

FIGURE 3 shows an exemplary schedule or exhibition plan followed in exhibiting performances on four different channels throughout a three hour period; and

FIGURE 4 shows a detailed timing diagram of a preferred system operation that occurs around the time when one exhibition of a pay-per-view program ceases and another pay-per-view exhibition begins.

25

#### Best Mode for Carrying Out the Invention

Referring first to FIGURE 1, there is seen a schematic representation of a system 10 for distributing video programming in accordance with a preferred embodiment of the present invention. System 10 includes a video server 11 interfaced to a headend 12 of a wideband transmission system 13 having a plurality of channels. Transmission system 13 couples a multiplicity of addressable converter boxes 14 located in respective subscriber premises 36.

35

FIGURE 2 is a block diagram of the video server 11 shown in FIGURE 1. Video server 11 includes, among other elements, a serving computer 15 and software, a control bus 16, and a plurality of video players 17.

5       The serving computer 15 performs all control functions (e.g. start, stop, rewind, etc.) for the video players 17 in response to an exhibition plan or schedule (discussed below). Computer 15 also gathers video player usage data. The serving computer 15 is loaded with the  
10 exhibition plan, which specifies timing instructions. The serving computer 15 is programmed to provide real time outputs in response to these timing instructions. The exhibition plan may be provided to the serving computer 15 on magnetic memory 19 or transferred directly from a  
15 master scheduling computer 20. The exhibition plan includes a five-digit event code, a title, rating code, channel, starting times, dates, run time, and price for each exhibition of a performance.

The serving computer 15 also monitors the status of  
20 the video players 17 and operates promotional channel video players 18. Operations are controlled through a menu. A printer 21 prints a hardcopy listing the program to be placed in each video player 17. An operator display provides video player status monitoring. A status screen  
25 indicates whether a video playback machine is playing, rewinding, waiting to start playing, not in use, setting-up, or has failed. Provision of an alarm during video player failure is included. Monitors (not shown) show what is on a selected channel.

30       A commercially available parallel bus 16 provides a communications path between an output port of serving computer 15 and video player 17 and 18, allowing the serving computer 15 to automatically operate the control features of the video players. Bus 16 includes one or  
35 more bus controller panels which provide control signals in response to the real time outputs of the computer 15.

These in turn operate video player parallel decoders, each of which can control several video players.

Video players 17 are used for playing recorded media containing programs in television format or for coupling a  
5 line feed from a live program. The video players 17 may be any controllable player means such as video cassette recorders (VCRs) or disk players. Pre-recorded video cassette format is the most abundant medium for video  
10 storage in the preferred embodiment of the present invention. Video cassette players may be software controlled for automatic rewind and playback of tapes. Optical disks are another storage medium. An attractive feature of optical disk players is the capability of  
15 multiple playing heads reading a disk.

Each video player has a control port coupled to the bus 16 and is responsible to the control signals. Each video player also has an output providing television signals for coupling to a separate corresponding channel via the headend 12 of the transmission system 13 (see  
20 FIGURE 1).

The video players 17 play video selections starting at times specified by the exhibition plan. Each player can be set for different start times. At the start time, the medium is played from the start of the active program.  
25 At the end of the program the medium is automatically rewound, if necessary, and set to the program start.

In the preferred embodiment of the present invention, at least two of the video players 17 are loaded with duplicate recorded media and controlled to play at  
30 staggered or overlapping time intervals. This staggered timing of a single program on multiple channels allows subscribers to have access to desired video nearly on demand, as discussed below in connection with FIGURES 3-4.

The medium is changed in the video server in either  
35 of two circumstances. The first is when the exhibition plan dictates that a different program will start at a

certain time and on a certain channel and the existing video medium should be removed and a new medium inserted. Accordingly, an operator may replace a given tape 30 to a library 32 and select a different tape 30 from library 32  
5 for insertion in players 17-18 in accordance with scheduling instructions.

The second circumstance occurs if the medium degrades with usage and has been played a specified number of times. It is then replaced with a fresh copy. In the  
10 preferred embodiment, master scheduler 20 processes a given schedule to determine when a program has been played a predetermined number of times. The predetermined number is selected so that the chances of program degradation and mechanical tape problems are extremely small when the  
15 number of playings are kept below the predetermined number. This information is passed to video server computer 15. When this predetermined number of playings is achieved, a message is printed that instructs a user to replace a particular tape. In addition, by processing the  
20 schedule, master scheduler 20 anticipates when new media is needed to replace old media. Scheduler 20 prints appropriate reports which inform a user of when to acquire new recording media and of the quantities to acquire.

During a pause, such as rewinding, the input from  
25 another source cuts through the video player and becomes the player output which is shown on the channel. This enables the viewer's channel to show another video source such as a promotional or text channel during times when the player is not showing a program. Arrangements for a  
30 promotional channel are described below.

The video players 17 have stereo audio capacity. Since it is desirable to operate audio through balanced pairs for common mode rejection, two audio outputs are connected to a pair of unbalance-to-balance buffer  
35 amplifiers. Each video player's output signal is coupled to a corresponding channel at headend 12.



Each video player 17 output is coupled to its own corresponding channel on the transmission system. The video output of the video server is connected through scrambling means in headend 12. Each signal is selectably  
5 scrambled at headend 12 before being placed on transmission system 13 (see FIGURE 1).

Video server 11 provides a promotional channel. The promotional channel operates similarly to a program channel, except each promotional segment is shorter in  
10 length than a program and is played continuously on one of two promotional video players 18. The two players alternately play identical preview segments. As one is playing, the other is rewinding. The promotional channel appears to play continuously. The switch from one video  
15 player to the other is set at a regular interval which does not interfere with controller operations of the other channels.

The promotional channel continuously shows promotional programming such as program previews, event  
20 promotions, order instructions, and programming information. A short promotional segment may be repeated back-to-back on a recorded medium so that the medium does not have to be rewound as frequently, thereby reducing medium wear. Information on the promotional channel is  
25 changed as required, e.g. monthly, according to the programming schedule. The promotional channel operations are software controlled by the serving computer 15.

A character generator 22 is coupled to the serving computer 15 for providing a menu in television format  
30 representing a programming schedule. The menu includes the specific times at which the beginnings of the video programs may be viewed and, if necessary, the channels upon which the video programs may be viewed. Server computer 15 continuously synchronizes the menu information  
35 with the operation of program video players 17. The output of the character generator 22 is coupled

unscrambled through headend 12 to a channel designated for text.

The output of the character generator 22 is also connected to the input of the first promotional video player. The output of the first promotional video player is connected to the input of the second promotional video player. The output of the second promotional video player is connected to a channel designated for promotionals. If both promotional video players 18 are in a non-play condition, then the character generator 22 output is automatically connected to the promotional channel.

The promotional channel output signal also couples through a distribution amplifier 34 so that it may be fed to the plurality of program video players 17. When any channel is not supplied with video from its video player 17, the promotional channel is automatically exhibited. Accordingly, when a video player 17 is being rewound, the promotional channel's programming is automatically broadcast over the channel assigned to the video player 17.

With reference back to FIGURE 1, the programs and promotions are distributed on an assortment of different channels of the transmission system 13. Transmission system 13 may be configured as broadcast, satellite, cable, or fiber. Headend 12, includes a scrambler 23, which selectably scrambles the channels. FIGURE 1 shows all channels from video server 11 being routed through scrambler 23 for completeness. However, in the preferred embodiment, only program channels are actually scrambled. Moreover, the scrambling is switched off and on through control signals provided by a downstream controller 24. Controller 24 receives scheduling information from master scheduler 20 and controls scrambling in real time in accordance with the scheduling information. While FIGURE 1 shows controller 24 as being a separate component from serving computer 15 of video server 11 (see

FIGURE 2), those skilled in the art will understand that serving computer 15 may be adapted to additionally operate as downstream controller 24.

Addressable converter box 14, or simply converter 14, enables downstream access to a channel. In other words, converter 14 allows and controls the viewing of programming in its respective subscriber premises 36. Addressable converter box 14 represents conventional equipment, which is known to those skilled in the art. Generally speaking, a preview or promotional period of programming is shown unscrambled prior to the showing of each program. Converter 14 passes this promotional material toward a television receiver 29 without any attempt at unscrambling. Thus, the subscriber may view intelligible programming. This unscrambled transmission continues for a predetermined period of time, preferably past the beginning of the program. However, downstream controller 24 eventually scrambles the program and instructs all enabled converters 14 in a global transmission to all premises 36 to begin unscrambling the program. For converters 14 which have been enabled, subscribers may continue to view intelligible programming. However, converters 14 which have not been enabled do not unscramble the received signals and therefore send only unintelligible programming, if any, toward television receiver 29.

Converter 14 includes a receiver or transmitter/-receiver section 40 which converts the received signals to baseband. A controller 42 portion of converter 14 includes a decoder 44 which looks for data in the baseband signals that are addressed to the converter 14. Controller 42 also controls a descrambler 46 so that incoming signals are selectably unscrambled. Such data may be addressed globally, so that all converters 14 interpret data as being directed toward them, or locally, so that only a specific signal converter 14 interprets

-10-

the corresponding data as being directed toward it. When such data is detected, controller 42 examines the data to determine whether it represents credit data, instructions for unscrambling an incoming scrambled signal on a  
5 specified channel or channels, instructions for refraining from unscrambling an incoming unscrambled signal on a specified channel or channels, instructions for enabling a specific channel or channels so it or they may later be unscrambled, and the like.

10 The preferred ordering system is impulse pay-per-view. In other words, a subscriber may view a preview or beginning of a program and instantly, on impulse, order the program for viewing at his or her premises 36. The ordering process allows ordering from a  
15 choice of different programs which start at various times. The preferred ordering process is capable of processing orders, both requesting and canceling service, in advance or up until some time into the event.

The ordering process also allows authorization for  
20 receiving orders prior to service delivery. Two types of authorization may be provided for: 1) authorization based on credit limitation, or 2) authorization based on parental control. Accurate records, correlated by program, are kept by the converter 14 until transferred to  
25 system 10 for analysis. Records include data on customer identification, events ordered and canceled (program title, start date and time), time and day of order transaction, blockage in ordering or receiving service, and price of program.

30 The present invention contemplates alternate embodiments for methods of ordering programming. In a first preferred embodiment, a subscriber accesses a keypad or remote control (not shown) for the subscriber's converter 14 to enter an order. A simple push of a button  
35 may successfully cause an order to be entered. The

-11-

converter 14 records the fact that an order has been placed in a memory 48, and associates the time of day and the channel being viewed with this information.

Converter 14 may also verify that credit limits and parental authorization permit the order. This order will enable converter 14 to unscramble the programming in response to a global unscramble signal received from system 10.

Preferably, downstream controller 24 of system 10 polls each set-top converter 14 daily. If converters 14 have collected billing data, controller 24 requests them to transfer this data to an upstream controller 25 of system 10. Such billing data may be transmitted either through the public switched telephone network (PSTN) 50 or over transmission system 13.

Alternatively, a subscriber may access a telephone 49, and place a telephone call to a predetermined number for system 10. Ordering and authorization data is thus placed through the PSTN 50 to system 10. This PSTN-directed data may be received at system 10 either by a customer service representative who operates a telephone 52 and transfers data to master scheduler 20, or by a substantially automated upstream controller 25. Controller 25 may include an automatic number indicator (ANI) 54 that automatically receives the telephone number of the calling party. Of course, PSTN 50 must automatically pass the telephone number, as is currently done in certain locations, to ANI 54 so that ANI 54 may receive it. This telephone number is used to identify the subscriber who is placing an order or transmitting authorization data. Automatic number identification is a conventional technology which is known to those skilled in the art of telephony.

A controller portion 56 of upstream controller 25 may control a conventional voice synthesizer 58 to return voice prompts back to the subscriber. Preferably, these

-12-

voice prompts instruct the subscriber to press various keys on the subscriber's telephone. For example, the voice prompts may request the subscriber to first enter a personal identification number (PIN) for security purposes. The voice prompts may request the subscriber to enter a channel number for the program that a subscriber wishes to view. A conventional audio response unit (ARU) couples to the phone line to detect dual tone multifrequency (DTMF) signals generated when the subscriber presses keys on the subscriber telephone and reports the numbers to controller for transmission to master scheduler 20.

When upstream controller 25 receives the billing data, it stores and formats the data for transfer to master scheduler 20. Scheduler 20 then passes the information on to billing computer 26. Billing computer 26 receives information for each transaction on the customer, the event code ordered, and any other necessary data to identify the event code with title, rating, channel, starting times as well as date, run time and price. Billing computer 26 processes this data and prints a bill which includes the program title, data, time, and price.

The system is adapted for transferring television programs from video server 11, i.e. upstream transmitter, over the transmission system 13 to a downstream video recorder 28 and television receiver 29 coupled to the converter 14. The downstream control signals may be sent on cable, fiber, or telephone lines, but preferably the same media the television signals are sent on. Control data which relate to establishing authorization levels, ordering programming, and cancelling programming are transmitted from individual subscriber premises 36 via an upstream data link, through upstream controller 25, to master scheduler 20 and billing computer 26. This

upstream data link may be provided by the PSTN 50 or by transmission system 13.

System 10 is operated substantially as illustrated in FIGURES 3-4 to provide video programming to subscribers  
5 nearly on demand. FIGURE 3 shows an exemplary schedule or exhibition plan followed in exhibiting performances on four different programming channels (see FIGURE 2) throughout a three hour period. Thus, FIGURE 3 illustrates the operation of four of program video players  
10 17 (see FIGURE 2). Each channel, labeled channels 70-73 in FIGURE 3, exhibits a combination of premium programming and promotional programming, as discussed above. The premium programming represents programming which subscribers must pay for an unscramble in order to render  
15 the programming intelligible. In other words, the premium programming represents pay-per-view (PPV) programming.

In order to provide near video on demand (NVOD) services, a single program or performance, labeled as program X in FIGURE 3, is exhibited simultaneously on each  
20 of channels 70-73. While each exhibition is simultaneously broadcast on transmission system 13, the exhibitions are offset or staggered in time relative to one another. In the example depicted in FIGURE 3, program X has a run length of around 110 minutes and a repeat  
25 factor of 120 minutes. Thus, on each of channels 70-73, program X is exhibited for 110 minutes. When program X finishes, promotional programming is exhibited for 10 minutes. While the promotional programming is being exhibited, tapes 30 (see FIGURE 2) upon which program X is  
30 recorded are rewound and queued for a subsequent exhibition. After 10 minutes of promotional programming, program X is again exhibited, starting from its beginning. This process of repeating program X every 120 minutes continues indefinitely, until overall exhibition plans  
35 call for the exhibition of different programming.

In the example depicted in FIGURE 3, exhibitions of program X are staggered 30 minutes from one another on channels 70-73. Thus, a first exhibition of program X begins at 7:00 on channel 70, a second exhibition of program X begins at 7:30 on channel 71, a third exhibition of program X begins at 8:00 on channel 72, and a fourth exhibition of program X begins at 8:30 on channel 73. In the preferred embodiment, 30 minutes after the exhibition of program X begins on channel 73, an exhibition of program X begins again on channel 70, and so on. Thus, a subscriber may view program X at any time that the subscriber prefers to view program X, within a 0-30 minute interval. This offset interval is relatively short in relation to the overall run time of the program. Generally speaking, this interval is sufficiently short that subscribers may make impulse decisions concerning programming that they wish to view. While program X may not be instantly available from its beginning at the precise minute a subscriber wishes to view it (i.e. "on demand"), program X is nearly available when a subscriber wishes to view it (i.e. "nearly on demand").

While a 30 minute offset interval has been described above, those skilled in the art will recognize that exhibitions of program X could likewise be staggered at 15 minute intervals or at any other interval that the bandwidth of transmission system 13 permits. If system 10 employs a 15 minute offset or staggering interval, then a 120 minute repeat factor program, such as program X, requires eight channels to provide NVOD services within a 0-15 minute interval.

In the preferred embodiment of the present invention, 28 channels are dedicated to providing PPV services. Accordingly, scheduling may be configured as desired to provide either a few exhibitions at a very short offset interval or more exhibitions at a longer offset interval.



-15-

The shorter the offset interval, the more "nearly" video programming becomes "on demand."

FIGURE 4 shows a detailed timing diagram of a preferred operation for system 10 around the time when one exhibition of a PPV program ceases and another PPV exhibition begins. This interval generally occurs around the time that promotional programming is being exhibited, as shown at detail 80 in FIGURE 3.

Trace A in FIGURE 4 presents substantially the same information as is presented for channel 70 in FIGURE 3. In particular, FIGURE 4 shows that an exhibition of a PPV performance ends at 8:50, followed immediately by 10 minutes of promotional programming. At 9:00 exhibition of the PPV performance begins again. Those skilled in the art will recognize that operation of system 10 similar to that illustrated in FIGURE 4 will take place for each of the channels that exhibit PPV programming, although the timing for such operation may be offset as discussed above.

As discussed above in connection with FIGURE 1, the PPV exhibition is scrambled. The control of scrambling is depicted in trace B of FIGURE 4. The scrambling is removed when the exhibition of the PPV program ends, which occurs at 8:50. The removal of scrambling at headend 12 (see FIGURE 1) is accompanied with a global data communication instruction to all addressable converter boxes 14 (see FIGURE 1) to cease unscrambling operations in connection with the subject channel, which is channel 70 in this example. Accordingly, after 8:50 all subscribers may view the promotional programming, which preferably shows a preview of upcoming PPV programs.

Even though the subsequent exhibition of PPV programming begins at 9:00, the PPV programming remains unscrambled for a predetermined interval, preferably around 10 minutes, after the beginning of the PPV programming. This interval is referred to as a tease

interval. During the tease interval a subscriber may view the beginning of PPV programming even though the subscriber has not yet ordered the program. However, after the end of the tease interval, the PPV program is again scrambled. The scrambling of PPV programming at headend 12 is accompanied with a global data communication instruction to all subscriber's addressable converter boxes 14 to begin unscrambling operations in connection with the subject channel. However, as discussed above, only those addressable converter boxes 14 which have been enabled will engage in unscrambling operations with respect to the subject channel.

In order for an addressable converter box 14 to become enabled so that it will unscramble an incoming channel's trace C of FIGURE 4 shows a timing window within which orders for PPV programming are accepted. Preferably, this order request window begins when PPV exhibition begins, which occurs at 9:00 in this example. This window continues for a predetermined interval beyond the end of the above-discussed tease interval. Accordingly, scrambling is implemented to force subscribers to place orders if they wish to continue viewing PPV programming. When orders are placed, the respective addressable converter boxes 14 become enabled, and thereafter unscramble the incoming PPV programming.

As discussed above, the ordering process includes the ability for a subscriber to cancel a request order. As shown in FIGURE D, a cancel window begins when the order request window begins and extends beyond the order request window. Thus, a subscriber is given a finite interval within which to cancel his or her order. In the preferred embodiment, this cancel window extends for around 5 minutes past the end of the order request window.

With reference back to FIGURE 3, the methodology of the present invention contemplates the switching of subscriber viewing between channels to provide the

subscriber with a pause in viewing. For example, a subscriber may order program X at a point in time that causes his or her addressable converter box 14 to enable channel 70. However, while viewing program X, the viewer  
5 may be called away from television receiver 29 (see FIGURE 1) to answer a telephone, get snacks, or any other of a myriad of reasons. When this happens, the subscriber may simply re-order the programming. The subscriber's addressable converter box 14 will understand that it is  
10 currently in an enabled state and automatically revise enablement to a subsequent channel so that the subscriber may view the subsequent exhibition of program X, which in this case is channel 71. The subscriber will be permitted to make this switch a predetermined number of times, and  
15 billing computer 26 will process the multiple orders so that the subscriber does not pay for multiple entire viewings of PPV programming.

In summary, the present invention provides a method for providing improved pay-per-view programming to  
20 subscribers of a network. The present invention provides a method for delivering programs to subscribers nearly in an on demand or impulse basis. In addition, the present invention provides a method for controlling the scrambling and unscrambling of programming so that subscribers can  
25 view intelligible preview and promotional programming but not view substantial portions of PPV programming in an intelligible fashion until paying for it.

The present invention has been described above with reference to a preferred embodiment. However, those  
30 skilled in the art will recognize that changes and modifications may be made in this preferred embodiment without departing from the scope of the present invention. For example, the specific timing and channel numbers presented in FIGURES 3 and 4 are illustrative of an  
35 example of possible scheduling. Those skilled in the art will recognize that precise scheduling will depend on the

performances being exhibited. These and other changes and modifications which are obvious to those skilled in the art are intended to be included within the scope of the present invention.

5

10

15

20

25

30

35

Claims:

1. A method of providing video programs to subscribers via a transmission system that comprises  
5 capacity for a plurality of video channels, the method comprising the steps:

(a) storing the video programs in a controllable video player system;

(b) controlling the video player system, according  
10 to a predetermined schedule, in a manner that causes the video programs to be applied at specified times to specified channels of the wideband transmission system, according to which schedule the video player system is controlled in a manner that causes at least one selected  
15 video program to be simultaneously applied to a plurality of channels, with the respective starting times of the selected video program on the respective plurality of channels, with the respective starting times of the selected video program on the respective plurality of  
20 channels staggered by time intervals of relatively short period in relation to the run-time of the selected video program;

(c) processing video programs in a manner that renders those programs substantially unintelligible to  
25 subscribers;

(d) broadcasting the video programs to subscribers via the transmission system;

(e) processing a request from a subscriber to view the selected video program; and

30 (f) in response to the request from the subscriber, rendering the selected video program intelligible to the subscriber on an appropriate one of the plurality of channels to which the selected video program is simultaneously applied.

2. A method of providing video programs as defined in claim 1 wherein the request is processed in Step (e) by receiving the request in the form of a telephone call placed to a customer service representative.

5

3. A method of providing video programs as defined in claim 1 wherein the request is processed in Step (e) by an audio response unit (ARU) that responds to DTMF signals emanating from a subscriber's telephone set.

10

4. A method of providing video programs as defined in claim 3 additionally comprising the step of providing voice prompts to the subscriber in order to facilitate the request.

15

5. A method of providing video programs as defined in claim 1 wherein the processing of a request in Step (e) utilizes automatic number identification of the subscriber's telephone number.

20

6. A method of providing video programs as defined in claim 1 wherein the processing of a request according to Step (e) includes storing the request in equipment accessible by the subscriber and subsequently forwarding the request to a provider of the video programs.

25

7. A method of providing video programs as defined in claim 6 wherein the request is stored in an addressable converter box.

30

8. A method of providing video programs as defined in claim 6 wherein the processing a request according to Step (e) includes transmitting the request substantially immediately over the transmission system.

35

9. A method of providing a video program to a subscriber on a nearly-on-demand basis, the method comprising the steps:

5 storing the video program in a controllable video delivery system;

coupling the video delivery system to a transmission system that comprises a plurality of channels;

10 controlling the video delivery system in a manner that causes the video program to be sequentially applied to respective ones of the channels according to a predetermined schedule so that the starting time of the video program on each of the respective channels is offset from the starting time on one of the other channels by a time period that is substantially less than the run-time  
15 of the video program;

broadcasting the video program on the respective ones of the channels so that the video program appears simultaneously on those channels, but on a time-offset basis;

20 processing a request from a subscriber to view the video program; and

enabling the subscriber to view the video program in a nearly-on-demand mode so that the subscriber may view the beginning of the video program at a discrete point in  
25 time on a video channel that is selected from a plurality of available points in time on respective ones of the plurality of video channels.

10. A method of providing a video program as defined  
30 in claim 9, further including the step:

applying to one of plurality of channels a menu representing the schedule of the specific times at which the beginning of the video program may be viewed.

35 11. A method of providing a video program as defined in claim 10, further comprising the step:

prior to the beginning of the video program on a channel, performing on that channel, a preview of the video program.

5           12. A method of providing a video program as defined in claim 9 wherein the preview is performed for a limited period of time without request from the subscriber, but the remainder of the video program is viewable in an intelligible form by the subscriber only upon request of  
10 the subscriber.

13. A method of providing a video program as defined in claim 9, further comprising the steps:

enabling the subscriber to view promotional material  
15 related to the video program during a first interval prior to the starting time of the video program;

enabling the subscriber to view a beginning portion of the video program during a second interval immediately subsequent to the first interval;

20 enabling the subscriber to enter a request to view the video program during a third interval that includes within its duration substantially the entirety of the second interval; and

25 in the absence of a request from the subscriber to view the video program, rendering the video program unviewable in an intelligible form by the subscriber subsequent to the end of the second interval.

30 14. A method of providing a video program as defined in claim 13, wherein the third interval extends beyond the end of the second interval.

15. A method of providing a video program as defined in claim 13 further comprising the step:

35 during a fourth interval that substantially includes the third interval and a predetermined duration after the



third interval, responding to an indication of the subscriber's intent to cancel the request to view the video program.

5           16. A method of providing a video program as defined in claim 15 wherein the third interval extends beyond the end of the second interval.

10           17. A method of providing a video program to subscribers, the method comprising the steps:  
          storing the video program in a controllable video delivery system that provides at least two video outputs;  
          coupling the video delivery system to a transmission system that comprises a plurality of channels, so that a  
15           first output of the video delivery system is coupled to a first channel and a second output of the video delivery system is coupled to a second channel;  
          controlling the video delivery system in a manner that causes the video program to be applied to the first  
20           and to the second channels according to a predetermined schedule so that the starting time of the video program on the first channel is offset from the starting time on the second channel by an offset time period that is less than the run-time of the video program;  
25           broadcasting the video program on the first and the second channels so that the video program appears substantially simultaneously on those channels, but on a time-offset basis;  
          processing requests from subscribers to view the  
30           video program; and  
          enabling subscribers to view the video program on either the first or the second channel, according to the time at which the subscriber prefers to view the video program.

35

18. A method of providing a video program to subscribers as defined in claim 17 wherein, subsequent to processing an initial request from a subscriber and enabling the subscriber to view the video program on the first channel, the method includes the steps of subsequently processing a second request from the subscriber, the second request occurring before the video program has ended on the first channel, and enabling the subscriber to view the video program on the second channel.

19. A method of providing a video program as defined in claim 18 wherein requests are processed by receiving the requests in the form of telephone calls placed to a customer service representative.

20. A method of providing video programs as defined in claim 18 wherein requests are processed by an audio response unit (ARU) that responds to DTMF signals emanating from a subscriber's telephone set.

21. A method of providing video programs as defined in claim 20 wherein the ARU provides voice prompts to the subscriber in order to facilitate the request.

22. A method of providing video programs as defined in claim 18 wherein the processing of a request utilizes automatic number identification of the subscriber's telephone number.

23. A method of providing video programs as defined in claim 18 wherein the processing of a request includes storing the request in equipment accessible by the subscriber and subsequently forwarding the request to a provider of the video program.

24. A method of providing a video program as defined in claim 23 wherein the request is stored in an addressable converter box.

5 25. A method of providing video programs as defined in claim 23 wherein the processing of a request includes transmitting the request over the transmission system to a provider of the video program.

10 26. A method of enabling a viewer to view the beginning of a video program at a selected one of a plurality of predetermined discrete points of time, the method comprising the steps:

(a) operating a controllable video server that  
15 provides a plurality of outputs in a manner that causes at least portions of the video program to appear concurrently, but not synchronously, at respective outputs of the video server;

(b) applying the outputs of the video server to  
20 respective downstream channels of a transmission system that includes a plurality of downstream channels and at least one upstream channel;

(c) controlling the operation of the video server  
25 according to a predetermined schedule, which schedule causes the beginning of the video program to occur at staggered starting times on the respective channels so that the starting times on at least a selected pair of the channels are offset by a time interval that is short with respect to the run-time of the video program;

(d) broadcasting the video program to viewers via  
30 the transmission system;

(e) receiving from a viewer a request transmitted  
via an upstream channel, which request indicates the viewer's preference to view the video program at a  
35 specific time; and

(f) enabling the viewer to view the video program on a channel determined by the specific time at which the viewer requests to view the video program.

5           27. A method as defined in claim 26 comprising the step:

          receiving the request through channel-selection equipment accessible to the viewer and coupled to the transmission system, which channel-selection equipment  
10 includes means for storing the request prior to transmission of the request via the transmission system.

          28. A method as defined in claim 27 comprising the step:

15           extracting the request from the channel-selection equipment via the transmission system.

          29. A method as defined in claim 27 comprising the steps:

20           compiling, in a master scheduler, said master schedule to define the times at which the beginning of the video program will occur on respective ones of the plurality of downstream channels, and

          providing information compiled by the master  
25 scheduler to the controllable video server.

          30. A method as defined in claim 29 wherein information compiled by the master scheduler includes  
30 (i) identification of the video program, (ii) the run-time length of the video program, and (iii) starting time of the active portion of the video program.

          31. A method as defined in claim 30 wherein information compiled by the master scheduler includes the  
35 dates and starting times of the video program on respective channels of the transmission system.

32. A method as defined in claim 29 comprising the step:

providing information compiled by the master scheduler to a billing processor.

5

33. A method as defined in claim 29 comprising the step:

providing information compiled by the master scheduler to the channel-selection equipment that is accessible to the viewer.

10

34. A method as defined in claim 29 comprising the step:

providing information by the master scheduler that anticipates a need to acquire a quantity of media on which the video program is recorded.

15

35. A method as defined in claim 26 wherein Step (a) includes loading a plurality of storage media, on which media the video program is stored, into a plurality of video players and wherein Step (c) includes causing the plurality of video players to be sequentially activated so that the beginning of the video program appears at a time T1 on a first downstream channel, at a time T2 on a second downstream channel, ..., and at a time TN on an Nth downstream channel, wherein T2 through TN occur prior to the end of the video program on the first downstream channel.

20

25

36. A method as defined in claim 35 comprising the step:

30

receiving the request through channel-selection equipment accessible to the viewer and coupled to the transmission system, which channel-selection equipment includes means for storing the request prior to transmission of the request via the transmission system.

35

37. A method as defined in claim 36 comprising the step:

extracting the request from the channel-selection equipment via the transmission system.

5

38. A method as defined in claim 36 comprising the steps:

compiling, in a master scheduler, said master schedule to define the times at which the beginning of the video program will occur on respective ones of the plurality of downstream channels, and

10

providing information compiled by the master scheduler to the controllable video server.

15

39. A method as defined in claim 38 wherein information compiled by the master scheduler includes (i) identification of the video program, (ii) run-time length of the video program, and (iii) starting time of the active portion of the video program.

20

40. A method as defined in claim 39 wherein information compiled by the master scheduler includes the dates and starting times of the video program on respective channels of the wideband transmission system.

25

41. A method as defined in claim 38 comprising the step:

providing information compiled by the master scheduler to a billing processor.

30

42. A method as defined in claim 38 comprising the step:

providing information compiled by the master scheduler to the channel-selection equipment that is accessible to the viewer.

35

43. A method as defined in claim 38 comprising the step:

providing information by the master scheduler that anticipates a need to acquire a quantity of media on which  
5 the video program is recorded.

44. A method as defined in claim 36 wherein, prior to Step (f), the video program is processed in a manner that renders the program substantially unviewable in an  
10 intelligible form by a viewer.

45. A method as defined in claim 36 wherein, subsequent to processing an initial request from a subscriber and enabling the subscriber to view the video  
15 program on the first channel, the method includes the step of subsequently processing a second request from the subscriber, the second request occurring before the video program has ended on the first channel, and enabling the subscriber to view the video program on the second  
20 channel.

46. A method as defined in claim 26 wherein, subsequent to processing an initial request from a viewer and enabling the viewer to view the video program on an  
25 initial channel, the method includes the step of subsequently processing a second request from the viewer, the second request occurring before the video program has ended on the initial channel, and enabling the viewer to view the video program on another channel as determined by  
30 the time of occurrence of the second request.

47. A method as defined in claim 46 wherein, prior to Step (f), the video program is processed in a manner that renders the video program substantially unviewable in  
35 an intelligible form by a viewer.

48. A method as defined in claim 47 comprising the steps:

5 compiling, in a master scheduler, said master schedule to define the times at which the beginning of the video program will occur on respective ones of the plurality of downstream channels, and

providing information compiled by the master scheduler to the controllable video server.

10 49. A method as defined in claim 48 wherein information compiled by the master scheduler includes (i) identification of the video program, (ii) run-time length of the video program, and (iii) starting time of the active portion of the video program.

15

50. A method as defined in claim 48 comprising the step:

providing information compiled by the master scheduler to a billing processor.

20

51. A method as defined in claim 50 comprising the step:

25 providing information compiled by the master scheduler to the channel-selection equipment that is accessible to the viewer.

52. A method as defined in claim 51 comprising the step:

30 providing information by the master scheduler that anticipates a need to acquire a quantity of media on which the video program is recorded.

53. A method of providing a video program comprising the steps:

35



enabling a subscriber to view promotional material related to the video program during a first interval prior to the starting time of the video program;

enabling the subscriber to view a beginning portion  
5 of the video program during a second interval immediately subsequent to the first interval;

enabling the subscriber to enter a request to view the video program during a third interval that includes within its duration substantially the entirety of the  
10 second interval; and

in the absence of a request from the subscriber to view the video program, rendering the video program unviewable by the subscriber in an intelligible form subsequent to the end of the second interval.

15

54. A method of providing a video program as defined in claim 53, wherein the third interval extends beyond the end of the second interval.

20 55. A method of providing a video program as defined in claim 53 further comprising the step:

during the fourth interval that includes the third interval and a predetermined duration after the third interval, responding to an indication of the subscriber's  
25 intent to cancel the request to view the video program.

56. A method of providing a video program as defined in claim 55 wherein the third interval extends beyond the end of the second interval.

30

35

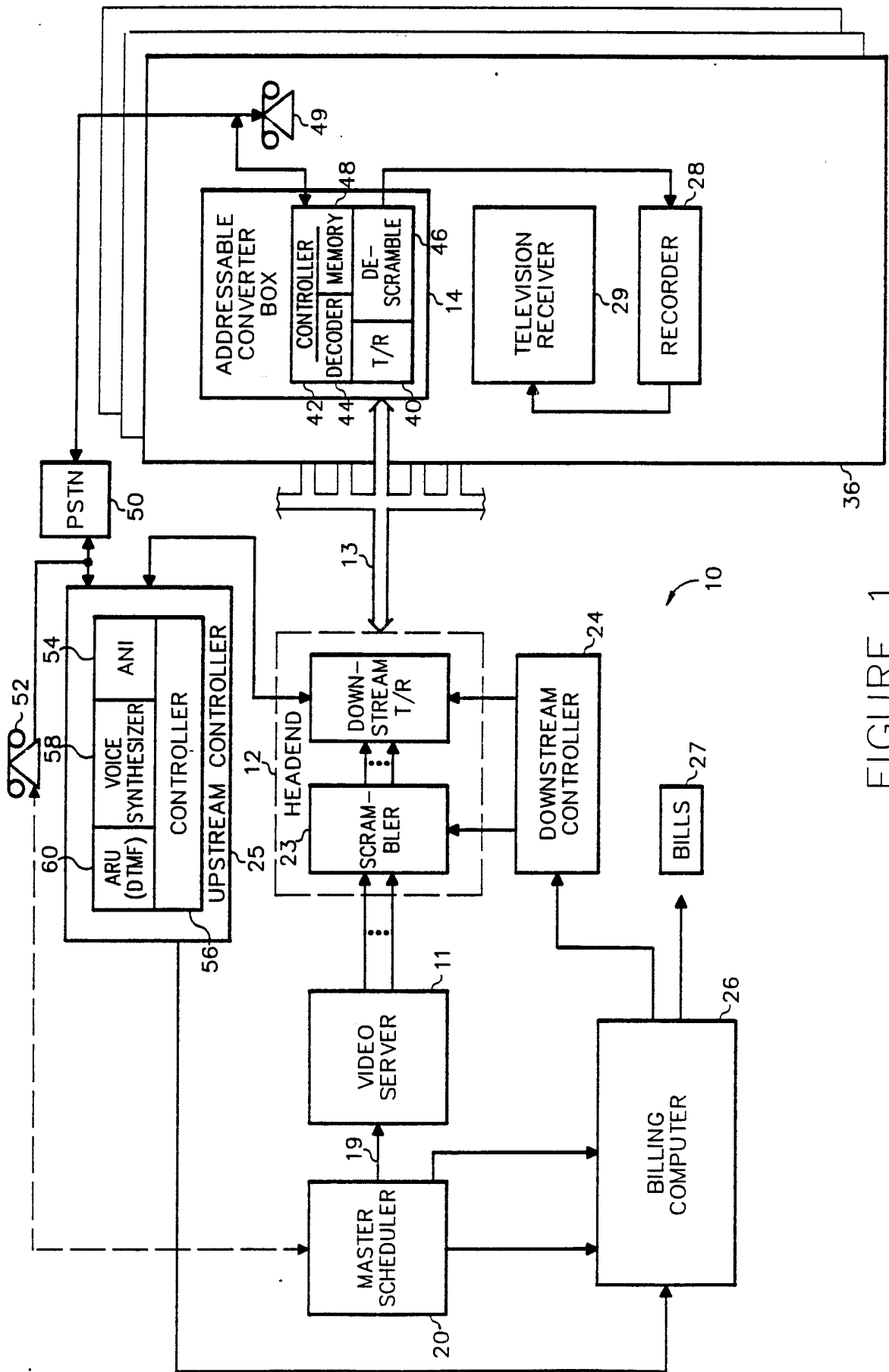

FIGURE 1

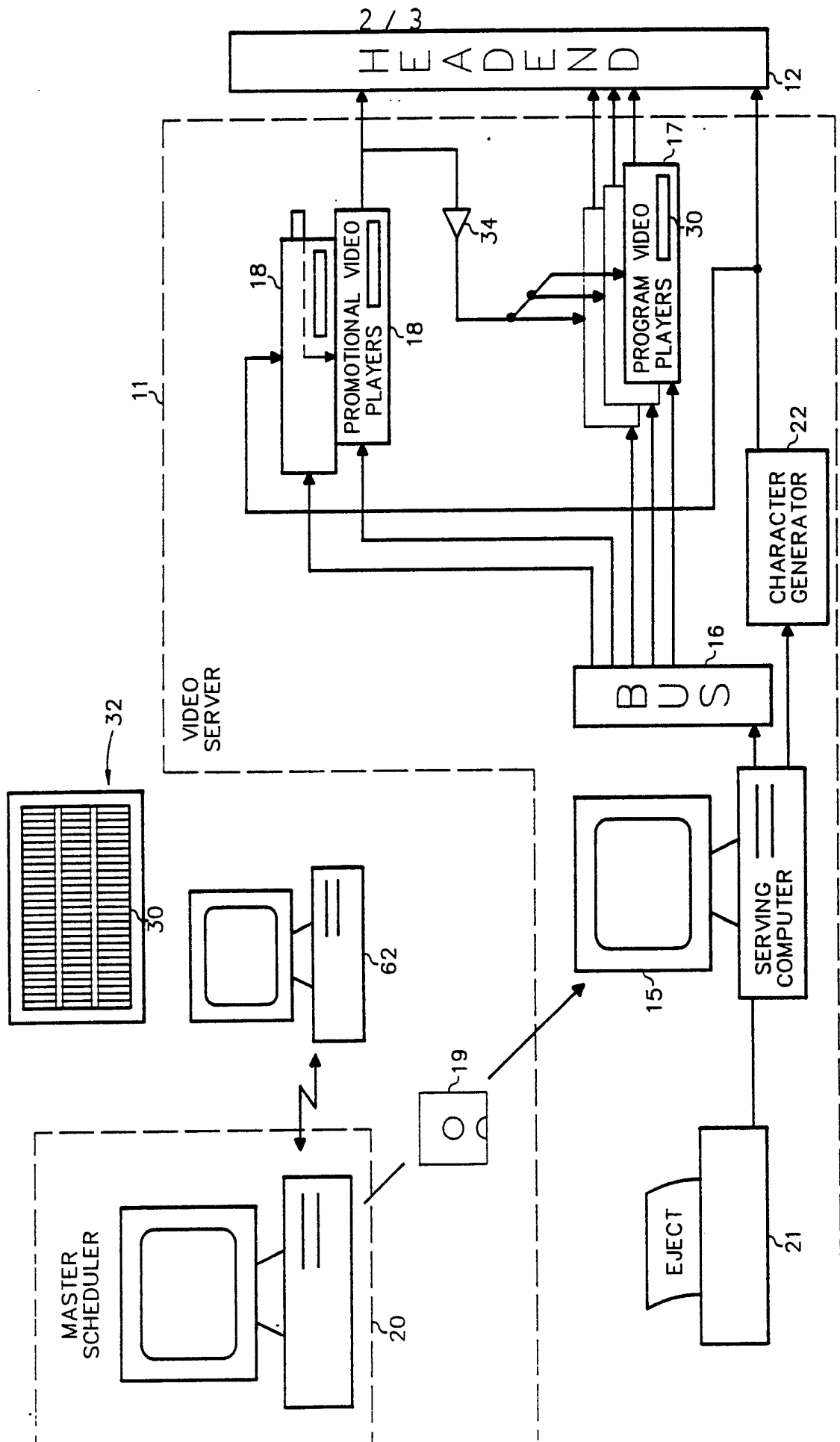

FIGURE 2

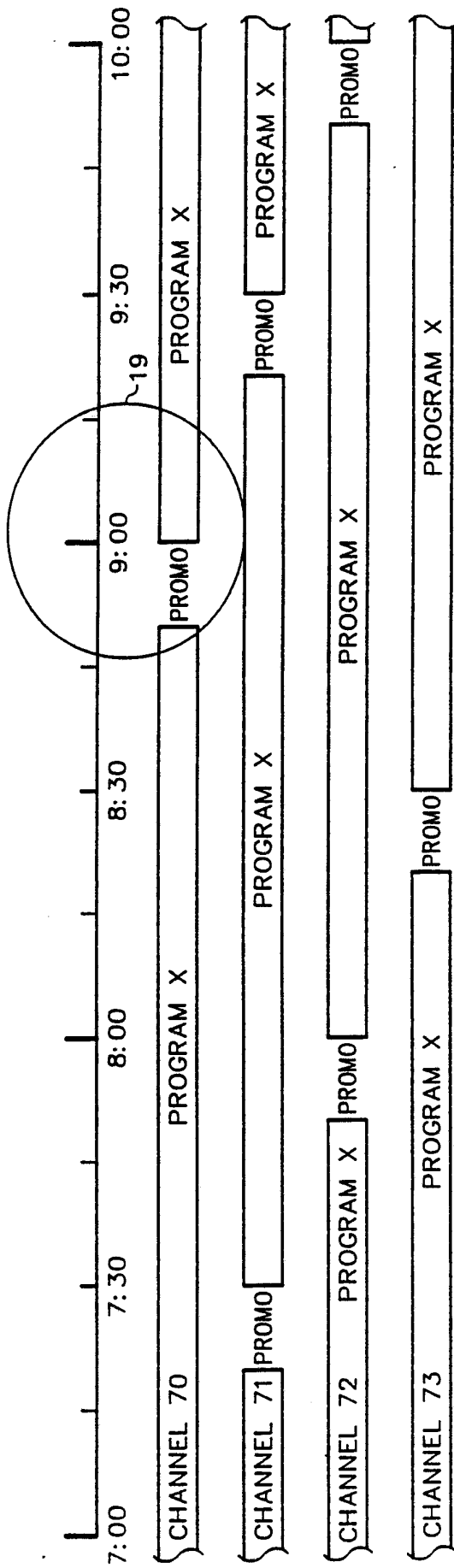

FIGURE 3

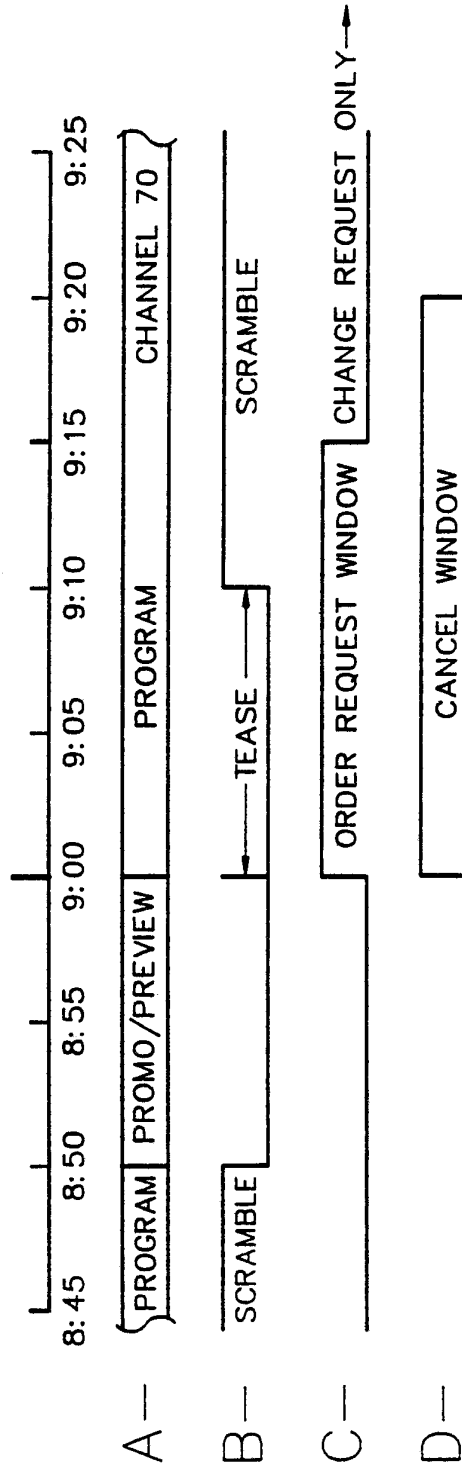

FIGURE 4

# INTERNATIONAL SEARCH REPORT

International Application No. PCT/US91/09446

<b>I. CLASSIFICATION OF SUBJECT MATTER</b> (if several classification symbols apply, indicate all) <sup>6</sup>		
According to International Patent Classification (IPC) or to both National Classification and IPC		
IPC(5): HO4H 1/02; HO4N 7/167		
U.S. Cl.: 455/ 5, 6 ; 358/86		
<b>II. FIELDS SEARCHED</b>		
Minimum Documentation Searched <sup>7</sup>		
Classification System	Classification Symbols	
U.S. CL:	455/3, 4, 5, 6, 5g 358/86, 84 380/ 5, 10	
Documentation Searched other than Minimum Documentation to the Extent that such Documents are Included in the Fields Searched <sup>8</sup>		
<b>III. DOCUMENTS CONSIDERED TO BE RELEVANT <sup>9</sup></b>		
Category <sup>9</sup>	Citation of Document, <sup>11</sup> with indication, where appropriate, of the relevant passages <sup>12</sup>	Relevant to Claim No. <sup>13</sup>
Y, P	US, A, 5,003,384 (DURDEN ET. AL.) 26 MARCH 1991 See Figures 1-7, Column 10	53-56
Y	US, A, 4,949,170 (YANAGIDAIRA ET. AL.) 14 AUGUST 1990 See Entire Document.	1-3,5-9,17-25 27, 28, 46, 47
Y	US, A, 4,949,187 (COHEN) 14 AUGUST 1990 See Entire Document.	1-3,5-9, 17-25 27, 28, 46, 47
A, P	US, A, 4,995,078 (MONSLOW ET. AL.) 19 FEBRUARY 1991 See Entire Document.	1-52
A	US, A, 4,947,244 (FENWICK ET. AL.) 07 AUGUST 1990 See Entire Document.	1-52
<p><sup>9</sup> Special categories of cited documents: <sup>10</sup></p> <p>"A" document defining the general state of the art which is not considered to be of particular relevance</p> <p>"E" earlier document but published on or after the international filing date</p> <p>"L" document which may throw doubts on priority claim(s) or which is cited to establish the publication date of another citation or other special reason (as specified)</p> <p>"O" document referring to an oral disclosure, use, exhibition or other means</p> <p>"P" document published prior to the international filing date but later than the priority date claimed</p> <p>"T" later document published after the international filing date or priority date and not in conflict with the application but cited to understand the principle or theory underlying the invention</p> <p>"X" document of particular relevance; the claimed invention cannot be considered novel or cannot be considered to involve an inventive step</p> <p>"Y" document of particular relevance; the claimed invention cannot be considered to involve an inventive step when the document is combined with one or more other such documents, such combination being obvious to a person skilled in the art.</p> <p>"&amp;" document member of the same patent family</p>		
<b>IV. CERTIFICATION</b>		
Date of the Actual Completion of the International Search	Date of Mailing of this International Search Report	
21 FEBRUARY 1992	27 MAR 1991	
International Searching Authority	Signature of Authorized Officer	
ISA/US	CHI PHAM <i>Wanda Banks</i>	