

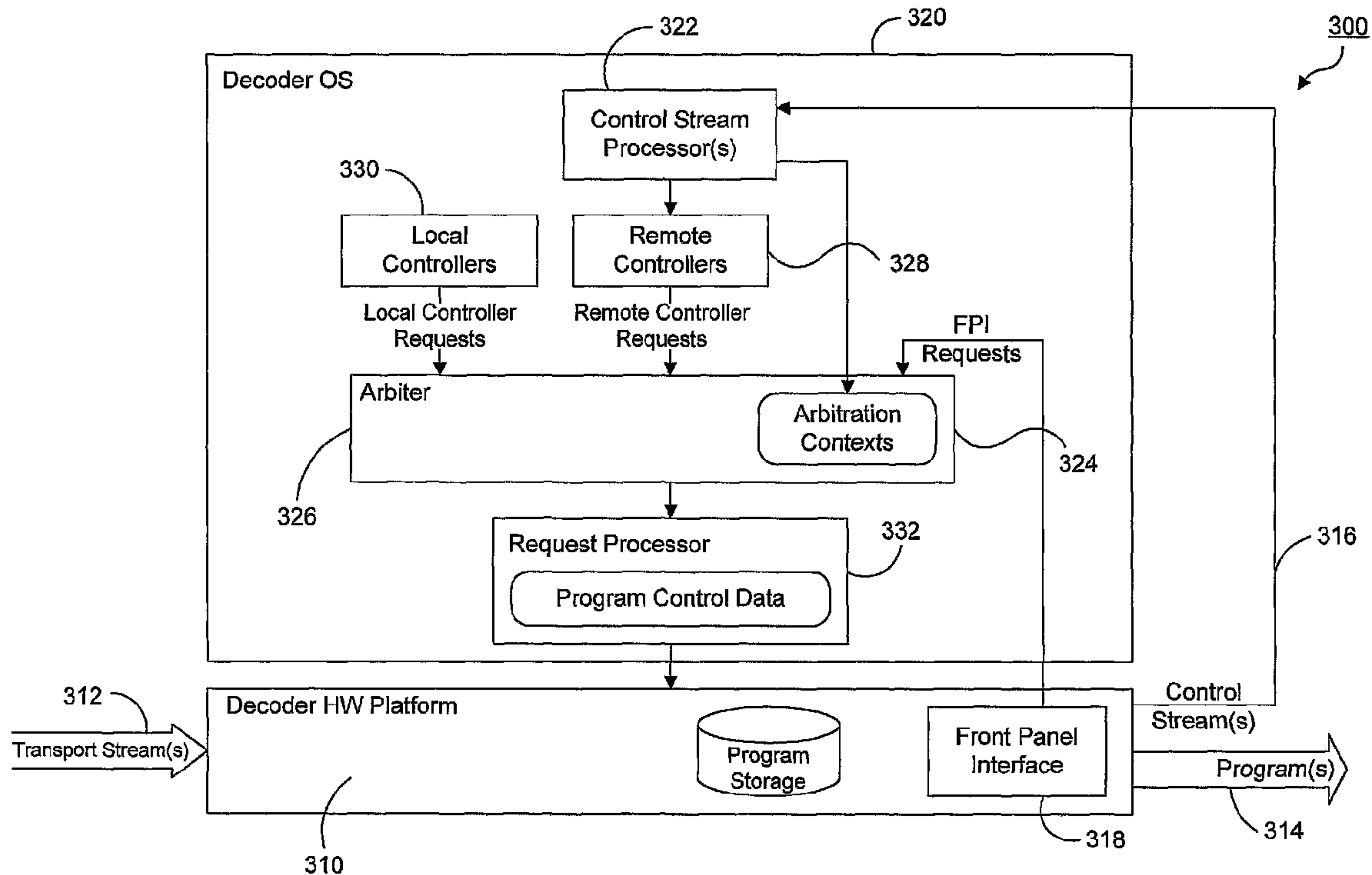

(86) Date de dépôt PCT/PCT Filing Date: 2006/04/14
 (87) Date publication PCT/PCT Publication Date: 2006/10/26
 (85) Entrée phase nationale/National Entry: 2007/10/12
 (86) N° demande PCT/PCT Application No.: US 2006/014164
 (87) N° publication PCT/PCT Publication No.: 2006/113484
 (30) Priorité/Priority: 2005/04/15 (US10/907,791)

(51) Cl.Int./Int.Cl. *H04N 7/16* (2006.01)
 (71) Demandeur/Applicant:
SCIENTIFIC-ATLANTA, INC., US
 (72) Inventeurs/Inventors:
LUCCISANO, ALEXANDER, CA;
SHELDRIK, WAYNE STEVEN, CA;
GAMMIE, KEITH B., CA;
WOO, ARTHUR SAN, CA;
CROOKES, BRIAN, CA
 (74) Agent: GOWLING LAFLEUR HENDERSON LLP

(54) Titre : SYSTEME DE COMMANDE AVEC FLUX DE COMMANDE GLOBAUX POUR COMMANDER UNE PLURALITE DE DECODEURS
 (54) Title: CONTROL SYSTEM WITH GLOBAL CONTROL STREAM FOR CONTROLLING A PLURALITY OF DECODERS



(57) **Abrégé/Abstract:**

Control system with global control stream for controlling a plurality of decoders. The control system simultaneously controls a plurality of decoders at a remote location by using a global control data stream. A global control stream is a collection of data used for global applications. There are currently three global data streams - disaster recovery, live event control, and storage control. The streams may exist on a shared or independent PID. A control server forms a transport stream and the global control stream is injected into the transport stream by the control server.

(12) INTERNATIONAL APPLICATION PUBLISHED UNDER THE PATENT COOPERATION TREATY (PCT)

(19) World Intellectual Property Organization
International Bureau



(43) International Publication Date
26 October 2006 (26.10.2006)

PCT

(10) International Publication Number
WO 2006/113484 A3

- (51) International Patent Classification:
H04N 7/16 (2006.01)
- (21) International Application Number:
PCT/US2006/014164
- (22) International Filing Date: 14 April 2006 (14.04.2006)
- (25) Filing Language: English
- (26) Publication Language: English
- (30) Priority Data:
10/907,791 15 April 2005 (15.04.2005) US
- (71) Applicant (for all designated States except US): **SCIENTIFIC-ATLANTA, INC.** [US/US]; 5030 Sugarloaf Parkway, Lawrenceville, Georgia 30044 (US).

Arthur San [CA/CA]; 24 Sonneck Square, Scarborough, Ontario M1E 1A9 (CA). **CROOKES, Brian** [CA/CA]; 10 Hopedale Avenue, Toronto, Ontario M4K 3M7 (CA).

(74) Agents: **LAFFERTY, Wm. Brook** et al.; Scientific-Atlanta, Inc., Intellectual Property Dept., 5030 Sugarloaf Parkway, Lawrenceville, Georgia 30044 (US).

(81) Designated States (unless otherwise indicated, for every kind of national protection available): AE, AG, AL, AM, AT, AU, AZ, BA, BB, BG, BR, BW, BY, BZ, CA, CH, CN, CO, CR, CU, CZ, DE, DK, DM, DZ, EC, EE, EG, ES, FI, GB, GD, GE, GH, GM, HR, HU, ID, IL, IN, IS, JP, KE, KG, KM, KN, KP, KR, KZ, LC, LK, LR, LS, LT, LU, LV, LY, MA, MD, MG, MK, MN, MW, MX, MZ, NA, NG, NI, NO, NZ, OM, PG, PH, PL, PT, RO, RU, SC, SD, SE, SG, SK, SL, SM, SY, TJ, TM, TN, TR, TT, TZ, UA, UG, US, UZ, VC, VN, YU, ZA, ZM, ZW.

(84) Designated States (unless otherwise indicated, for every kind of regional protection available): ARIPO (BW, GH, GM, KE, LS, MW, MZ, NA, SD, SL, SZ, TZ, UG, ZM, ZW), Eurasian (AM, AZ, BY, KG, KZ, MD, RU, TJ, TM), European (AT, BE, BG, CH, CY, CZ, DE, DK, EE, ES, FI, FR, GB, GR, HU, IE, IS, IT, LT, LU, LV, MC, NL, PL, PT, RO, SE, SI, SK, TR), OAPI (BF, BJ, CF, CG, CI, CM, GA, GN, GQ, GW, ML, MR, NE, SN, TD, TG).

- (72) Inventors; and
- (75) Inventors/Applicants (for US only): **LUCCISANO, Alexander** [CA/CA]; 13 Millward Crescent, Ajax, Ontario L1T 4M6 (CA). **SHELDRIK, Wayne Steven** [CA/CA]; 57 Rolling Acres Drive, Whitby, Ontario L1R 2B8 (CA). **GAMMIE, Keith B.** [CA/CA]; 51 Hawkrigde Avenue, Markham, Ontario L3P 1W1 (CA). **WOO,**

[Continued on next page]

(54) Title: CONTROL SYSTEM WITH GLOBAL CONTROL STREAM FOR CONTROLLING A PLURALITY OF DECODERS

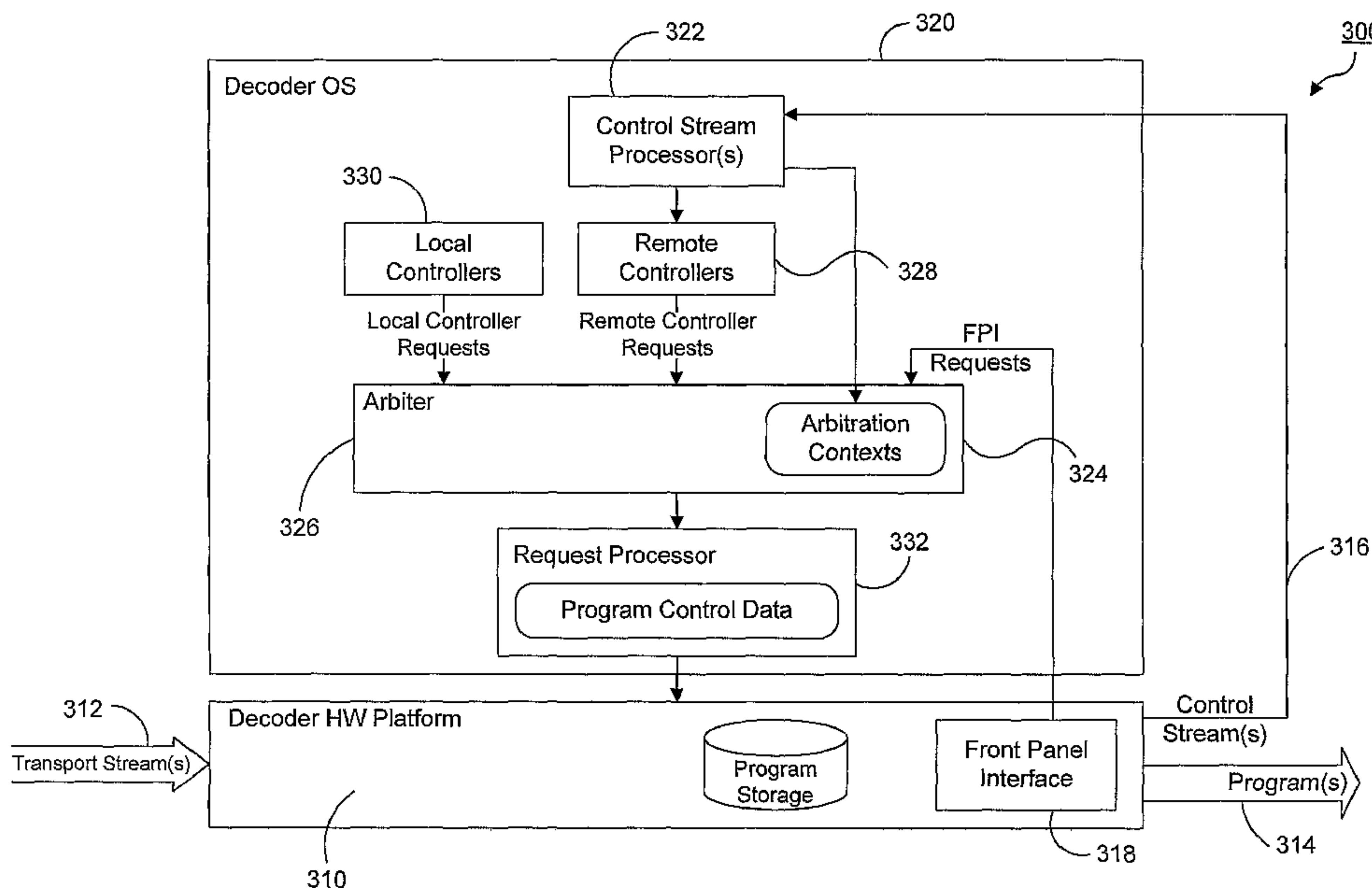

(57) Abstract: Control system with global control stream for controlling a plurality of decoders. The control system simultaneously controls a plurality of decoders at a remote location by using a global control data stream. A global control stream is a collection of data used for global applications. There are currently three global data streams - disaster recovery, live event control, and storage control. The streams may exist on a shared or independent PID. A control server forms a transport stream and the global control stream is injected into the transport stream by the control server.

WO 2006/113484 A3

WO 2006/113484 A3



Published:

— *with international search report*

(88) Date of publication of the international search report:

12 July 2007

For two-letter codes and other abbreviations, refer to the "Guidance Notes on Codes and Abbreviations" appearing at the beginning of each regular issue of the PCT Gazette.

CONTROL SYSTEM WITH GLOBAL CONTROL STREAM FOR CONTROLLING A PLURALITY OF DECODERS

CROSS-REFERENCE TO RELATED PATENT APPLICATIONS

5 The present U.S. application is related to U.S. applications entitled "UPLINK
SIGNALING FOR GLOBAL DECODER CONTROL" with attorney docket number A-
10496 and "STORAGE CONTROL SYSTEM" with attorney docket number A-10504,
which are incorporated herein by reference, and have been filed concurrently with the
present application.

10

FIELD OF THE INVENTION

 This invention relates in general to broadband communications systems, and more
particularly, to the remote signaling from an uplink to a decoder for the purpose of program
15 scheduling and coordinating decoder controllers.

DESCRIPTION OF THE RELATED ART

 Hybrid fiber/coax (HFC) broadband networks contain four primary components:
20 the headend, the AM fiber optic link, the distribution plant, and customer premises. The
most important is the headend, where signals from multiple sources are received and are
conditioned or cleaned up and placed on an RF carrier. Once signals have been prepared
for delivery, they are combined onto a single cable and are ready to be sent over the
network.

25 The three most common types of signals received at the headend include off-air
signals, satellite signals, and local origination signals. However, satellite signals are the
most common type of signal passing through the headend. Satellite signals include any
signal transmitted from an earth station to an orbiting satellite, then retransmitted back
down to earth. Satellite signals follow three route segments from the transmitting earth
30 station to the receiving earth station. First, signals are transmitted from earth to an
orbiting satellite on a path referred to as the uplink; signals are received by a transponder
on a satellite; signals are retransmitted from the transponder to a receiving earth station

over the downlink. The transponder amplifies the incoming signal and changes its frequency for the downlink journey to avoid interference with uplink signals.

FIG. 1 illustrates a satellite broadcast network 100. At the uplink facility 110, program content is stored on video servers controlled by a broadcast automation system. Any analog content at the network playout center is compressed using encoders and then multiplexed with the content delivered from the video file servers. The Network Operations Center (NOC) 120 is responsible for overall control and co-ordination of the uplink and the downlink sites. The headend 130 may include one or more server devices for providing broadband signals, such as video, audio, and/or data signals. The headend 130 has numerous decoders 140 which preferably each have a mass storage device 150, such as a hard disk drive.

The addition of mass storage devices in the digital television broadcast distribution network enables new applications and enhances existing ones. The headend would have the ability to store programs for delayed playback which allows customers to reduce the bandwidth requirements necessary for live playback.

BRIEF DESCRIPTION OF THE DRAWINGS

The invention can be better understood with reference to the following drawings. The components in the drawings are not necessarily drawn to scale, emphasis instead being placed upon clearly illustrating the principles of the invention. In the drawings, like
5 reference numerals designate corresponding parts throughout the several views.

FIG. 1 illustrates a satellite broadcast system.

FIG. 2 illustrates one embodiment of a general uplink system.

FIG. 3 illustrates one embodiment of a decoder with a hardware and software
platform.

10 FIG. 4 illustrates one embodiment of a hardware platform for the decoder of FIG. 3.

FIG. 5 illustrates a more detailed embodiment of the hardware platform for the decoder of FIG. 3.

15 FIG. 6 illustrates one embodiment of a software platform for the decoder of FIG. 3.

DETAILED DESCRIPTION

The embodiments of the invention can be understood in the context of a
20 broadband communications system. Note, however, that the invention may be embodied in many different forms and should not be construed as limited to the embodiments set forth herein. For example, transmitted broadband signals may include at least one of video/audio, telephony, data, or Internet Protocol (IP) signals, to name but a few. All examples given herein, therefore, are intended to be non-limiting and are provided in
25 order to help clarify the description of the invention.

FIG. 2 illustrates a generalized model of an uplink 200 that consists of functional components that perform specific duties. For example, an encoder 210 takes raw program input and encodes it into another format for output. It may take video and audio and encode it using an MPEG compliant algorithm, or it may take IP packets via Ethernet
30 and encode it using DVB MPE.

The generalized uplink 200 consists of encoders 210 used to encode programs for insertion into the transport stream and a multiplexer 220 to combine programs from the encoders 210 to form the transport stream. An uplink control server 230, such as a Network Centre Server, manages the uplink devices and configures the decoders 300

(FIG. 3) to listen to a selected set of global control streams, such as storage control stream (SCS) remote control streams. DVR control servers 240, 250 inject global control streams to control operation of the decoders 300, such as the operation of the program storage system. In one embodiment, the uplink 200 may also include a file distribution
5 DVR control server.

For example, because the control data stream is global, a plurality of decoders may be controlled simultaneously. Also, the addition of storage devices to the decoders helps to reduce and manage the amount of bandwidth required over the satellite transmission. Decoders with a storage system allow for program regionalization where
10 an entire program is substituted to overcome rights restrictions in particular locations as well as inject local stories and news. The storage system also allows for storing of programs transmitted to the headend prior to their scheduled playout time, but which may then be played out later during the scheduled time. This may be referred to as “store and forward”. For example, a program is stored for time zone delay or for multiple playbacks
15 in a short amount of time.

The present invention includes a control system for controlling groups of decoders simultaneously. A global control data stream is a collection of data used for global applications. This data stream is global in the sense the data is not addressed to any individual decoder or to any particular group of decoders as is an entitlement
20 management message (EMM). There are preferably at least three global control data streams – disaster recovery, live event control, and storage control. The streams may exist on a shared or independent PID. The global control data stream is a set of messages that are multiplexed into all signals of a network. A global control data controller is able to produce messages on the global PID on demand. The command to produce a message
25 may come from a human operator pushing a button in a control room, from an Automation System or time scheduled. Commands can be sent once or repetitively.

The decoder is initialized using the control system initialization EMM before it can respond to any control stream. This EMM delivers the network’s Customer Code and the control system Ids. Control system Ids exist for each control system: the storage
30 control system (SCS_Id), event control system (ECS_Id) and disaster recovery system (DR_Id). The Customer Code is a unique number assigned to each customer that has independent networks. If the decoder’s Customer Code does not match the one on transmission, then either the decoder has not been initialized or the decoder has changed networks. If the control system Id does not match, then it is possible that there are

multiple global control data streams on transmission for a particular customer.

Groups are assigned to a decoder as a block. Given the preference of unlimited groups, the current recommendation is for the decoder to support the storage of all available groups. The EMM can deliver up to 10 groups at a time. The decoder caches the group codes delivered in multiple EMMs until all have been received. When we are
5 sure a complete set has been received, they are written to non-volatile memory. All groups assigned to a decoder have equal priority, as far as the targeting system is concerned. When an event control table (ECT) is received, the decoder checks for group code matches. Any group code either matches or does not match. There is no
10 dependency on other group codes in deciding a match.

One aspect of the control system is group targeting. A control table of the global control data stream contains a list of subscriber group code matching instructions and each one must be checked against the set of decoder group codes. If a particular decoder is "targeted" then it performs the associated action. Targeting a decoder follows a simple
15 matching algorithm. The targeting system is order dependent. The uplink systems creating the stream and the decoders consuming the stream, implement the same algorithm. For this algorithm, the term targeted means that a particular decoder will implement an action. Any decoder not targeted will not be affected in any way by the actions received. The common control syntax consists of two loops. The first loop
20 provides the targeting list and the second provides the list of actions. Inside the first loop are descriptors and each descriptor provides a list of group codes. A descriptor is of limited size so it may be necessary to use multiple descriptors. Multiple descriptors are required to implement some more complex grouping methods.

Group targeting should follow these general rules. All decoders start not targeted.
25 The descriptor may direct all decoders to change its targeted state relative to the previous calculated value. Before a descriptor is processed, the current targeted state may be the same as it was at the end of the previous descriptor or inverted relative to what it was at the end of the previous descriptor. Each group code listed may change the current targeted state through one of the following tests: make a decoder targeted if the group
30 code matches; make a decoder not targeted if the group code matches; or make no change to the targeted state if the group code does not match.

The concept for this system is a single variable used to hold the decoders targeted state. This variable is initialized to not target when a new control table arrives to be processed. The state is modified first by the global control data stream and then by each

group code and matching instruction listed in the descriptor. This is repeated for each descriptor in the first loop. When all descriptors have been processed, the variable will be in one of two states, targeted or not targeted. If it is targeted, then the actions listed in the second loop are to be executed. If it is not targeted, then the decoder takes no action.

5 The control table delivers a list of actions that are to be executed if targeted. One action typically associated with an event control system is the force tune feature. A storage control system would typically issue actions of acquire or play out.

10 In one embodiment, still referring to FIG. 2, the DVR control server 240 injects a global control data stream, such as the storage control stream for directing the actions of the storage enabled decoders 300, shown in FIG. 3. The storage control stream may carry one or more of a Content Control Table (CCT), an Acquisition Control Table (ACT), and a Playout Control Table (PCT). Each of the tables share syntax and may contain specific types of action descriptors. The CCT is used to deliver the content that is expected to exist on a decoder now or in the future. Any content that is network controlled, but not listed in this table, is to be deleted from the decoder storage. The content may consist of video and audio content remotely triggered for acquisition. The decoder 300 will create an entry in its directory for each content description. When a playback command is given, the decoder 300 needs to determine if the content requested has actually been acquired or not. If the content reference id matches a previous directory entry, then this indicates that the entry should be renamed with the new information.

15 A content reference consists of two parts – the data that is delivered to the decoder 300 and the data that is locally managed on the hard drive 150. The CCT may be used to reserve disk space for high priority acquisitions and for storing local content from an Ethernet port or triggered by the front panel interface 318 (FIG. 3) independent of the global data stream control. The downloaded information is the content reference id, the filename the decoder 300 should use, the service id to tune to for live playout, the content type selector, and the expiry date. The locally maintained information is whether the content is present and the actual size of the content. Content deletion occurs if there is no entry in any new CCT. The CCT will always be sent as a complete table and may require multiple sections to deliver all of the information. The decoder 300 acquires all sections and save the information in temporary storage until it is complete. The table also contains a version number. If this value changes, then any in-progress download of the CCT should be restarted. If the version is the same as the previous table processed, the decoder 300 should be able to ignore it, since it is the same data. To avoid possible timing

problems, there should be some hysteresis provided before deleting a file. The decoder 300 should flag a file for delete and only perform the actual delete after a predetermined time, or after processing two complete CCT downloads for verification, or some similar type of self-check.

5 The ACT provides the date, time, and duration for a network controlled acquisition. Since the filename is delivered in the CCT, it is possible that there is no entry present at the time of the record. This could be due to a slow update of a CCT and a “record now” request. Less likely is an error in formatting the CCT or missed updates by the decoder. To alleviate this problem, the ACT will contain a copy of the filename and
10 expiry date. This should be used only if there is no entry in the local CCT. The ACT data would be updated when the actual content control data finally arrives. One concern with this duplicate data is the waste of bandwidth with long filenames. In one embodiment, the ACT will send a temporary unique filename and the real filename will be sent in the CCT and renamed upon arrival. The ACT will support recording of live
15 content from a local source, such as an RF tuner, DVB ASI input, or a special IP transport input. Content may also be copied from an existing file, a text message embedded in the ACT, or a URL addressed to content from a source connected to the decoder’s Ethernet port. The date and time provides an exact time to start recording. The duration in the ACT provides the record time window. The actual number of frames recorded is saved
20 by the decoder. The duration in the ACT is only of use to schedule recording. In addition to triggering the requests of content based upon a time window, the recording can also be triggered by uplink signaling embedded in the program such as cue triggers or digital program insertion (DPI) messages, uplink signaling embedded in the program within a time window, or a front panel input within a time window.

25 The PCT provides the date, time, and window for all scheduled playout sessions. The playout content includes live program content, stored program content, text messages embedded in the PCT, and text messages in a file. There are additional controls to allow for playout of a partial file, such as indexed into the file, for example, starting the playout other than at the beginning, and to loop the file, such as playing the content repetitively
30 within a time window. The window provides the time over which a playout should occur. However, the actual content may be less than, the same length, or longer than the window. When less, the decoder will need to fill the time with some default content until the window expires. If the content is too long, it should simply stop playing the content and return to the default content or follow on content that may be specified. If the PCT

does not specify any playout, default playout instructions, such as displaying a text message or tuning to a channel to playout a specific file, are followed.

Disaster recovery applications include alternative mapping services. For example, if a normally tuned signal is lost for a period of time, a backup service would be desired.

5 The backup service would tune the lost signal through an alternative satellite or carrier.

Event control applications include live programming such as sports, for example, which allows realtime force tuning of groups of decoders to follow regionalized sporting events or to provide alternate programs where rights restrictions prevent viewing of the sporting event.

10 The event control system, utilizing the global event control stream, is intended to force tune a plurality of decoders simultaneously. Authorization is normally an EMM function. However, the normal force tune operation using EMM distribution has too large a latency between when the first decoder and the last decoder retune. In addition to force tune, it is desirable to control the authorization state of the decoder. Deauthorizing
15 a decoder may be referred to as "blocking". Both event control and blocking are controlled by the global control data stream. However, the setup of the feature (i.e. Assigning group membership to subscribers and decoders) is preferably still done using EMM distribution.

Referring to FIG. 3, the decoder 300 includes a hardware platform 310 and a
20 software platform 320. The decoder hardware platform 310 takes in one or more transport streams 312 and plays out one or more programs 314. The decoder hardware platform 310 provides one or more of the controls streams 316 to the decoder operating system 320 and has a front panel interface 318 that is used to submit the requests to the decoder operating system 320. The decoder operating system 320 has one or more
25 control streams processors 322 to extract and forward arbitration contexts 324 to an arbiter 326 to resolve conflicting requests from controllers using the arbitration contexts 324, and requests to perform decoder functions to a remote controller 328 which submits the requests. The decoder operating system 320 also has local controllers 330 to manage login sessions into the decoder 300 and a requests processor 332 to handle the requests
30 from controllers producing program control data that is used to control the decoder hardware platform 310.

FIG. 4 illustrates one embodiment of the decoder hardware platform 310 in more detail where there are multiple transport stream inputs 410. The input source tuners 420 take one or more transport streams inputs 410 and produce a single transport stream

output to the input source routing matrix 430. The input source routing matrix 430
outputs the transport streams. Each output is capable of selecting any of the inputs and is
capable of being sent to a program source 440. The program sources 440 are used to send
a live program to the program routing matrix 450. The program can be sourced from the
5 transport stream by its service ID or sourced from content injected by the decoder
operating system 320. The program source 440 can also provide the SCS control streams.
Any SCS control stream in the transport stream may be extracted and sent to the decoder
operating system 320. It can be selected by its own service ID or included in the service
ID of the live program. The program routing matrix 450 has an input for the program
10 source 440 and the program reader 460. The program routing matrix 450 also has an
output for each program play out and program write and is capable of selecting from any
input.

The decoder hardware platform 310 also has a storage system 470 which includes
multiple storage units 480 and a program writer 482 capable of writing a program into a
15 storage unit and a program reader 460. The program outputs 484 are produced by a
translator 486 used to convert from multiple native program formats to a single playout
format. The program output 484 can also be produced by a playout to output, and the
program is groomed, such as output mapping and routing, to a form that can be consumed
by external equipment. Control stream translators 488 are used to convert the raw control
20 streams to a form that can be used by the decoder operating system 320. The front panel
interface 318 can be used to submit the requests to the decoder operating system 320.

FIG. 5 illustrates one embodiment of another decoder hardware platform 500.
The inputs can be multiple satellite RF input sources with DVB compliant PSI/SI streams
or an ASI input. The tuners 520 can tune among the inputs to provide a single compliant
25 transport stream from a carrier, which can be used to control tuner operation. The input
source routing matrix 530 is hardwired to provide the DVB compliant transport stream
from the tuners 520 to all the program sources. Live programs can be provided by the
transport stream. Each is identified by its DVB service ID and has a corresponding
program mat table (PMT). One program source is an MPEG program extractor 550. It is
30 only capable of extraction and provides the master control stream. The MPEG program
extractor 550 provides live MPEG program content used for playout and storage. It is not
directly available to the decoder operating system 320 for processing. The MPEG
program extractor 550 can provide file distribution control streams if the PMT of the
MPEG program carriers MPE data targeted for file distribution. A second program

source is a file distribution program extractor 540. It is capable of both extraction and injection of program content. The file distribution targeted MPE data streams are passed directly to the IP Packetizer 560. The file distribution streams may contain control data, playout content and storage content all of which are passed to the file distribution client residing in the decoder OS. MPEG content in the PMT is ignored. The file distribution client can write playout content directly to the IP Packetizer 560 for playout. The file distribution client can also inject storage content to be stored.

There are preferably four output playouts 570. Three for MPEG programs and one for file distribution programs. The MPEG program playout includes analog, Ethernet, and digital. The analog program playout is used to pay out programs presented on output ports that are intended to be connected to peripheral equipment that is used to display or record the program such as TV, radio tuner, VCR, etc. The Ethernet program playout is used to stream the IP data received in MPE format. The digital program playout is used to play out programs in the form of MPEG transport packets on a DVB ASI output. The file distribution program playout is of file distribution content on Ethernet. Translation of file distribution programs for MPEG playout and vice versa is also possible.

The decoder hardware platform 500 also has a storage system 470. If only one program may be written into storage at a time, multiple requests to write to storage will be performed in sequence. If only one program may be read from storage at a time then multiple requests to read from storage will be disallowed. Storage will be supported with a hard disk drive with a partition for MPEG programs and a partition for file distribution programs. The program routing matrix 450 will support the routing of MPEG live or stored programs to MPEG playout outputs and the MPEG storage unit. The program routing matrix 450 will also support the routing of file distribution live or stored programs to file distribution playout outputs and the file distribution storage unit.

FIG. 6 illustrates one embodiment of the decoder software platform 320 in more detail. There is a control stream processor 322 for each control stream. In one embodiment, the two control streams would be a global control data stream and a file distribution control stream. Each control stream processor 322 is capable of extracting remote control requests from the control stream and passing them to the appropriate control stream processor's appropriate remote controller 328. The remote control requests may be segmented for a subset of the decoder population. Each subset will have its own remote controller 328. The control stream processor 322 is capable of extracting

any program content present in the control stream and passing it to the appropriate remote controller. A controller pool 620 is an entity that is capable of processing remote control requests and submitting the resulting decoder requests to the arbiter 326, and processing program content and submitting the resulting decoder requests to the arbiter 326. The controller pool 620 may contain one FPI controller 630 to handle requests originating from the decoder's front panel interface 318, one or more local controllers 330 used to handle requests from any users locally logged into the decoder, and one or more remote controllers 328 used to handle any requests extracted from the control streams. The arbiter 326 has a context pool 640. Each controller in the controller pool 620 must have a corresponding context in the context pool 640. Rights/arbitration logic 650 makes use of the contexts in the context pool 640 to determine if a controller has the rights to issue the request or to access the necessary resources to perform the request. The rights/arbitration logic 650 also arbitrates controller conflicts. A controller conflict can be detected by determining if an operation needed to be performed by a request has been locked by a request from another controller or a resource needed by a request has been locked by a request from another controller. A controller conflict can be resolved by determining relative priorities of the conflicting requests or by determining interruptability of existing requests. A higher priority request may override another request if the outstanding request is interruptible. The rights/arbitration logic 650 also produces an arbitrated request that contains only changes that the controller has rights for. A request processor 332 processes the arbitrated request to produce the program control data used to drive the decoder hardware platform 310.

It should be emphasized that the above-described embodiments of the invention are merely possible examples, among others, of the implementations, setting forth a clear understanding of the principles of the invention. Many variations and modifications may be made to the above-described embodiments of the invention without departing substantially from the principles of the invention. All such modifications and variations are intended to be included herein within the scope of the disclosure and invention and protected by the following claims. In addition, the scope of the invention includes embodying the functionality of the embodiments of the invention in logic embodied in hardware and/or software-configured mediums.

CLAIMS

What is claimed is:

5

1. A system for simultaneously controlling a plurality of decoders at a remote location comprising:

a control server for forming a transport stream;

10

at least one global control stream injected into said transport stream by said control server; and

a remote location having a plurality of decoders for receiving said transport stream, said global control stream for controlling each of said plurality of decoders simultaneously.

15

2. The system of claim 1 wherein said decoders are storage enabled decoders and said global control stream is a storage control stream for directing said storage enabled decoders.

20

3. The system of claim 1 wherein said decoders are storage enabled decoders and said global control stream is a global storage control stream for directing said storage enabled decoders to store at least a portion of said transport stream prior to a scheduled playout time and to subsequently play said portion of said transport stream at said scheduled playout time, thereby reducing bandwidth requirements to said remote site of decoders at said scheduled playback time.

25

4. The system of claim 3 wherein said global storage control stream comprises at least one of the following: an acquisition control table for providing a schedule of contents to be recorded, a content control table for providing a list of all contents that exist on at least one of said decoders, and a playout control table for providing a schedule of content that is to be played out.

30

5. The system of claim 1 wherein said global control stream is a global event control stream for directing said decoders to implement an action.

6. The system of claim 5 wherein said global event control stream comprises an event control table for directing at least one decoder to retune.

7. The system of claim 5 wherein at least one of said decoders is variable between
5 blocked and unblocked states relative a group of subscribers.

8. The system of claim 5 further comprising an entitlement management message
(EMM) addressed to at least one specific said decoder to direct said specific decoder to
implement an action.

9. The system of claim 1 wherein said decoders are storage enabled decoders and
one said global control stream is a global storage control stream for directing said global
storage enabled decoders and another global control stream is a global event control
stream for directing said storage enabled decoders to implement an action.

10. The system of claim 1 further comprising a group of subscribers assigned a
subscriber group code to be received by at least one of said decoders, said at least one
decoder having a decoder group code, said at least one decoder adapted to implement an
action when said subscriber group code corresponds with said decoder group code.

11. An Control System (CS) for controlling a plurality of decoders at a remote
location, said CS comprising:

at least one of said decoders having a hardware platform and a software platform,
said hardware platform for receiving one or more transport streams, playing out one or
25 more programs, and providing one or more global control streams to said software
platform; and

said software platform for extracting and forwarding arbitration contexts to an
arbiter, said arbiter managing competing control streams by resolving conflicting requests
from controllers using said arbitration contexts.

12. The CS of claim 11 wherein said hardware platform includes a storage system
for allowing recording and playback of stored content and said arbiter manages requests
for recording and playback.

13. The CS of claim 11 wherein said global control data stream is a global data stream for controlling said decoders simultaneously.

5 14. The CS of claim 13 wherein said global control data stream is a global disaster recovery stream.

15. The CS of claim 13 wherein said global control data stream is a global event control stream.

10 16. The CS of claim 15 wherein said global event control stream comprises an event control table.

15 17. The CS of claim 15 wherein said global event control stream deauthorizes at least one of said decoders to block a program to a group of subscribers assigned to said at least one of said decoders.

18. The CS of claim 13 wherein said global control data stream is a global storage control stream for directing a storage system of said decoders.

20 19. The CS of claim 18 wherein said global storage control stream comprises at least one of the following: an acquisition control table for scheduling of content to be recorded, a content control table for listing all content stored in one of said decoders, and a playout control table for providing a schedule of content to be played out.

25 20. The CS of claim 13 wherein said global control data system comprises a global event control stream and a global storage control stream, said global event control stream and said global storage control stream on a single PID.

30 21. The CS of claim 11 wherein said plurality of decoders receive said global control data stream from an uplink.

22. The CS of claim 11 wherein said plurality of decoders receive and store at least some content distributed from an uplink prior to a scheduled playback time for said at least some content.

23. The CS of claim 22 wherein one of said decoders inserts said content stored by said decoder to be played at said scheduled playback time.

5 24. The CS of claim 11, wherein a group of subscribers having a subscriber group code assigned to one of said decoders is targeted to implement an action based upon a corresponding decoder group code.

10 25. The CS of claim 24 wherein said subscriber group code is contained within an event control table of said global control stream.

26. The CS of claim 24, wherein control syntax comprises a loop of descriptors providing a list of said subscriber group codes to be targeted.

15 27. The CS of claim 26 wherein said control syntax further comprises a second loop of descriptors for providing a list of actions.

20 28. The CS of claim 11 wherein a group of subscribers having a subscriber group code assigned to one of said decoders is not targeted to implement an action based upon a corresponding decoder group code.

25 29. The CS of claim 11 wherein said control system is an event control system (ECS) at least one entitlement management message (EMM) is received by said ECS and is addressed to at least one specific said decoder to direct said specific decoder to implement an action.

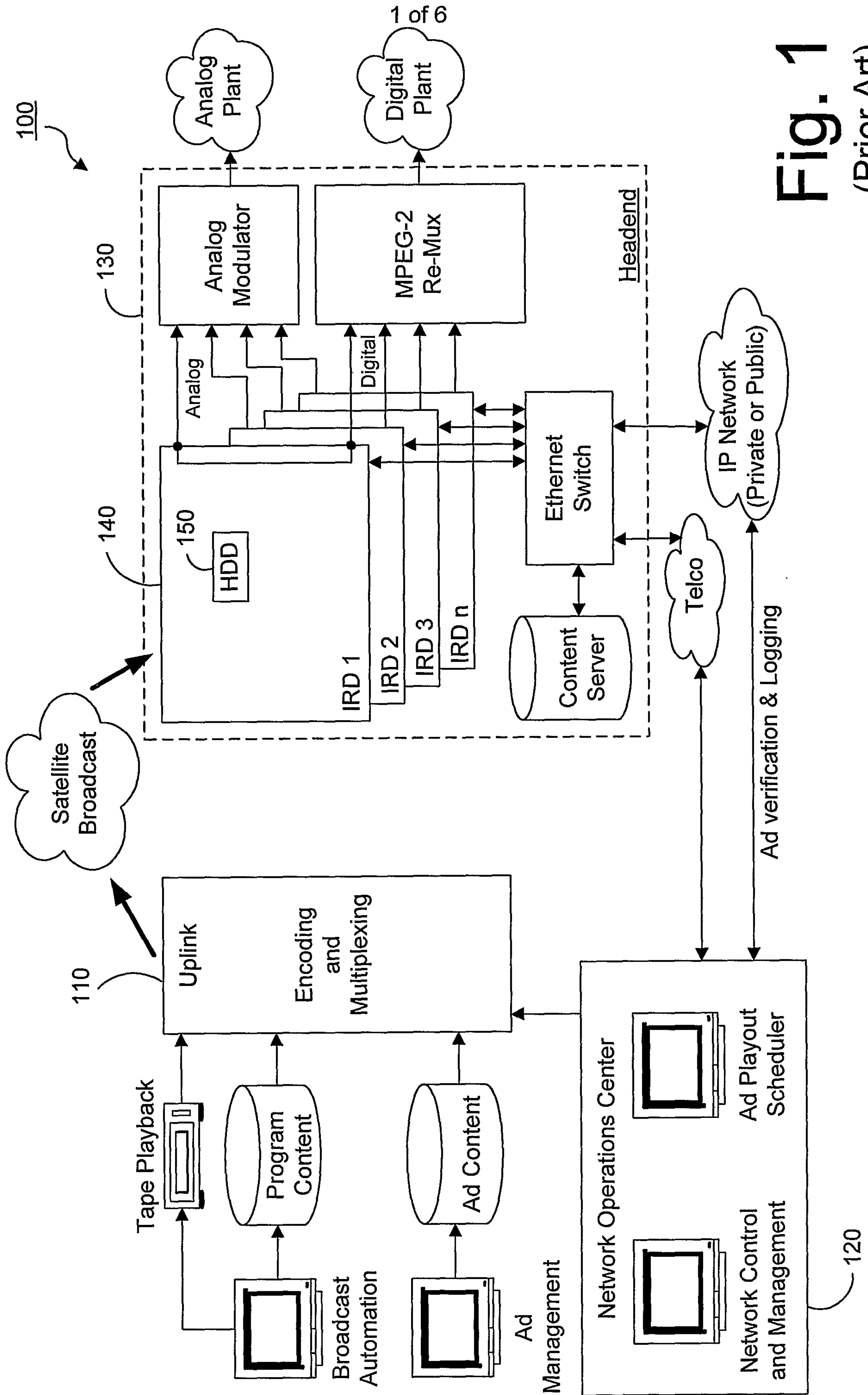

Fig. 1
(Prior Art)

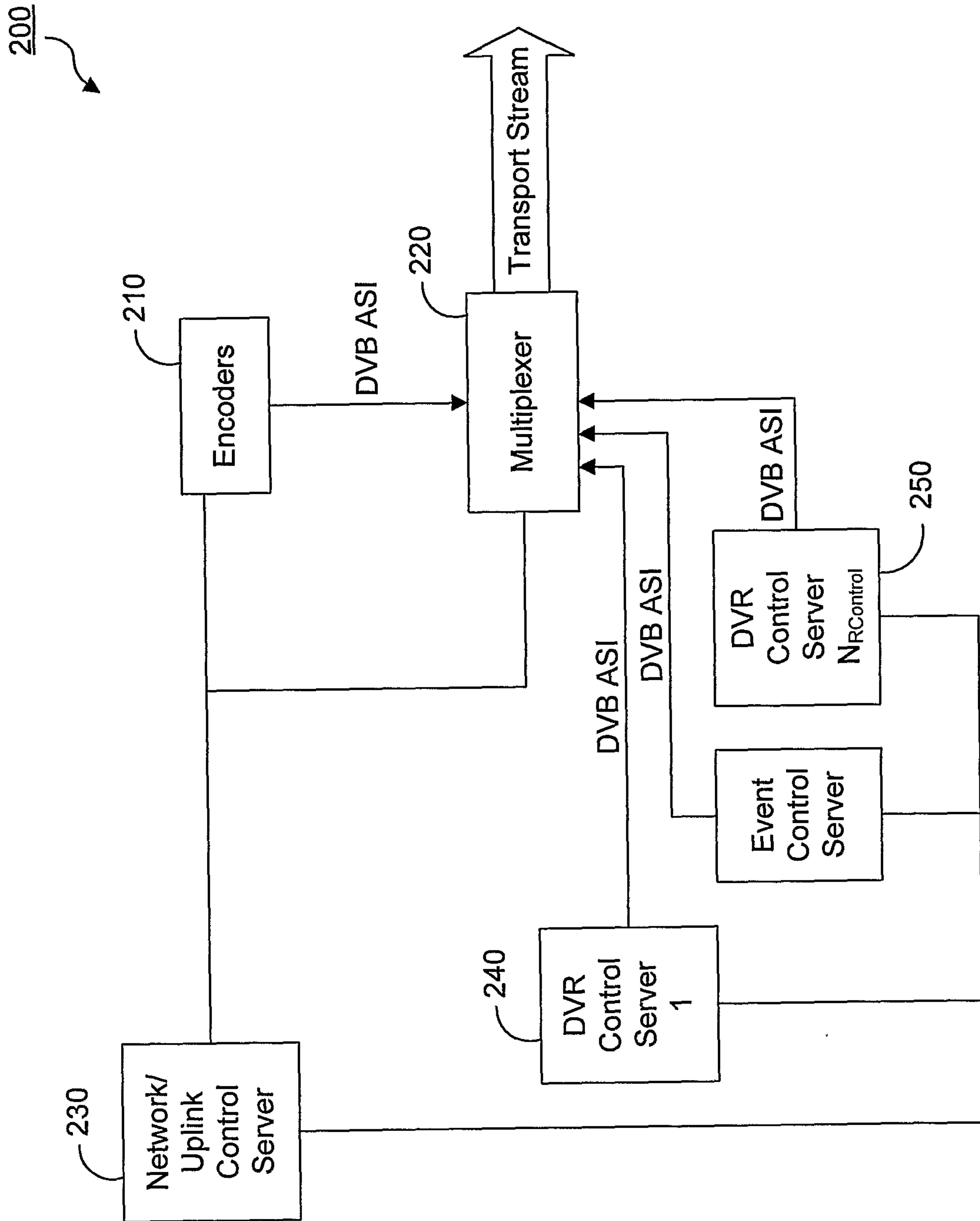

Fig. 2

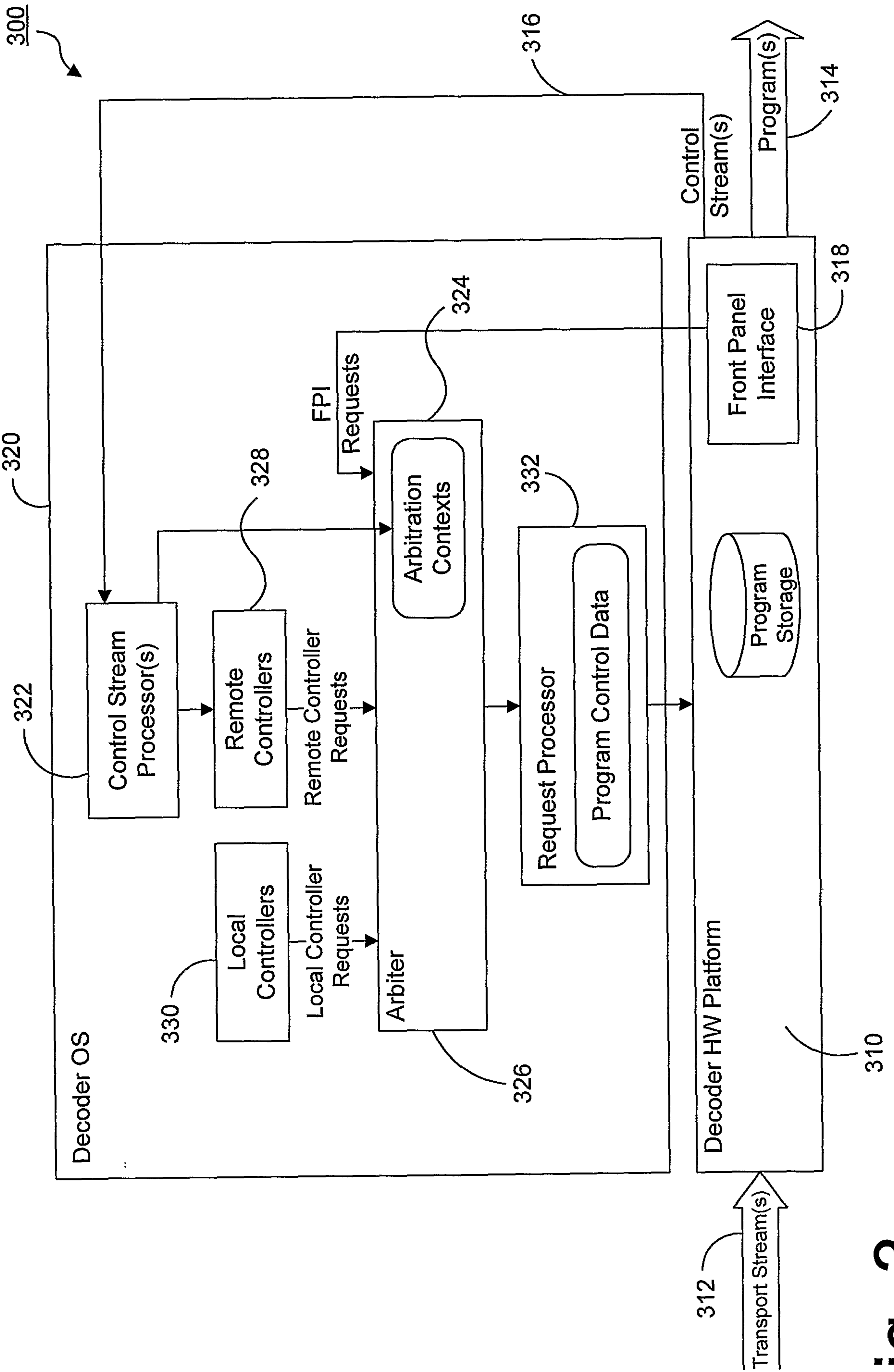

Fig. 3

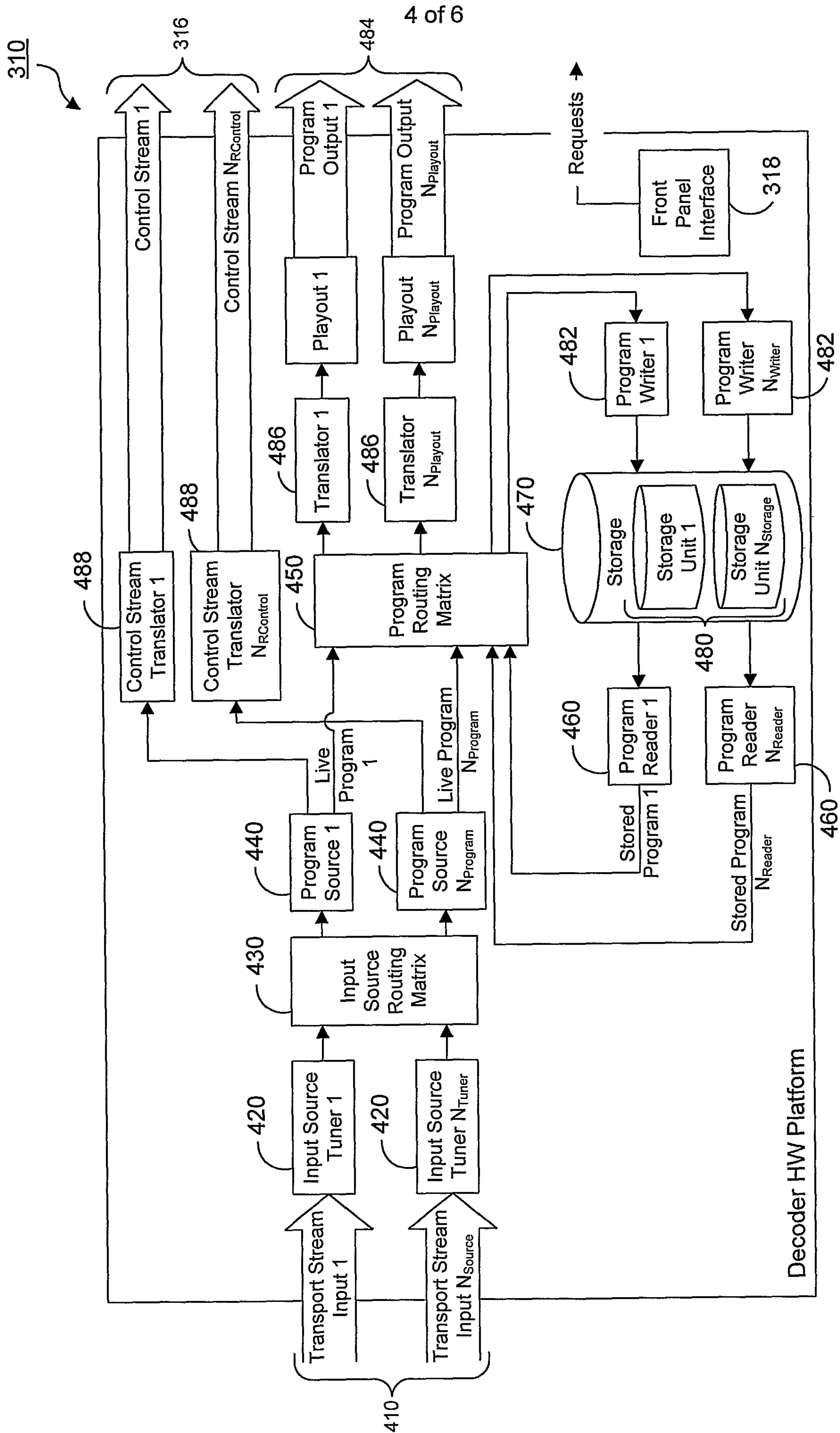

Fig. 4

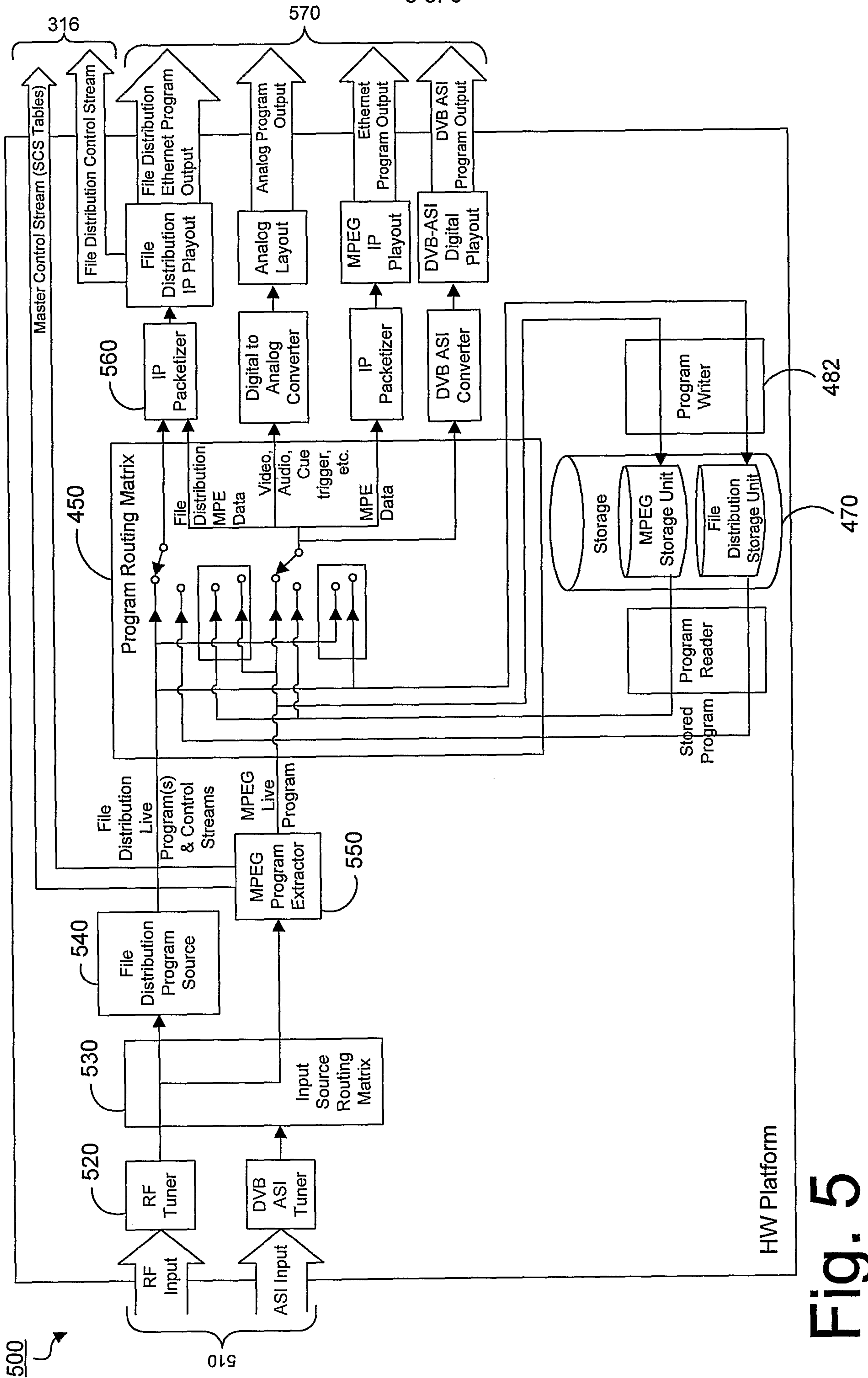

Fig. 5

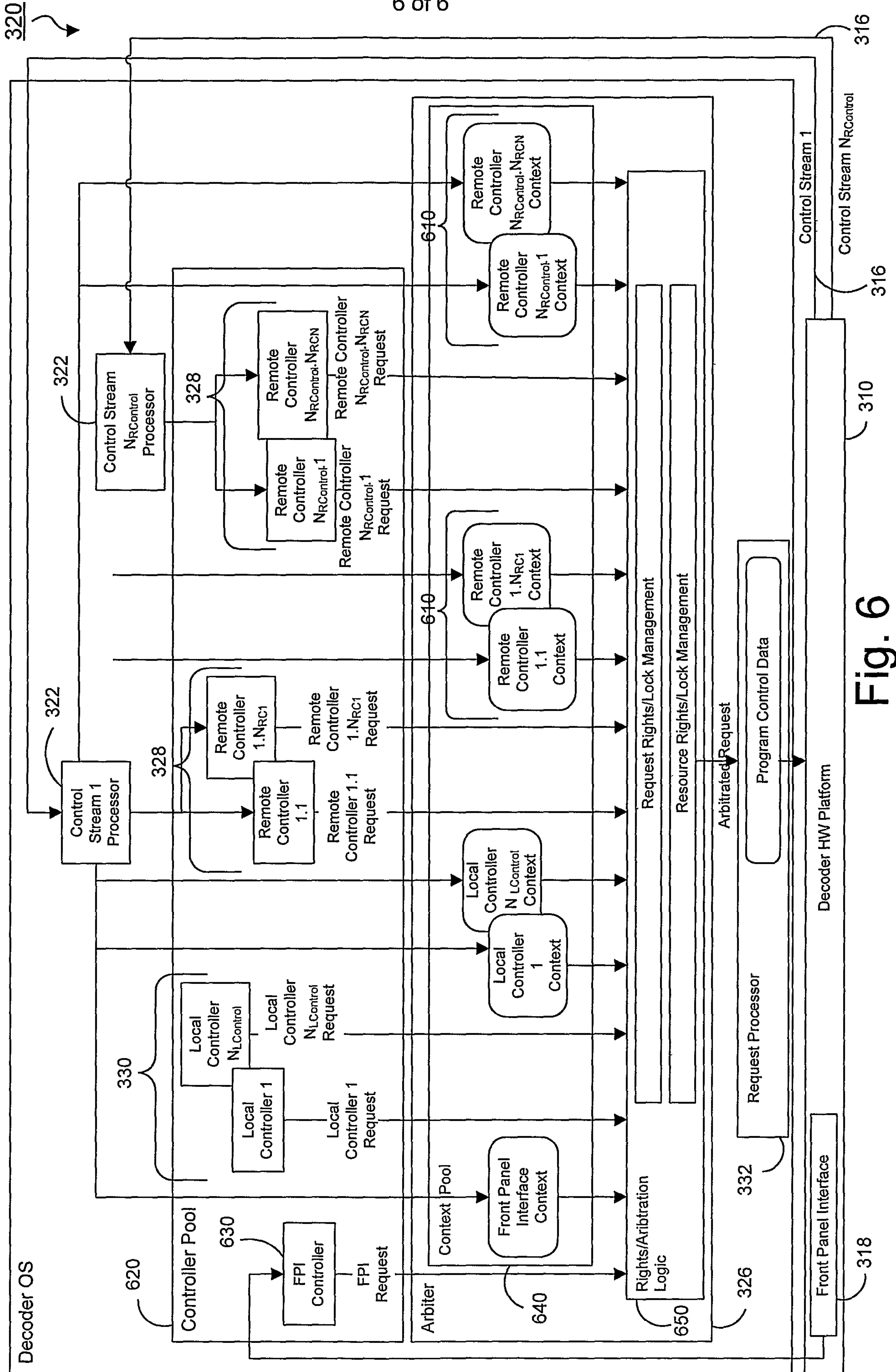

Fig. 6

