



(86) Date de dépôt PCT/PCT Filing Date: 2011/01/12  
 (87) Date publication PCT/PCT Publication Date: 2012/07/19  
 (45) Date de délivrance/Issue Date: 2017/10/10  
 (85) Entrée phase nationale/National Entry: 2013/04/16  
 (86) N° demande PCT/PCT Application No.: IT 2011/000009  
 (87) N° publication PCT/PCT Publication No.: 2012/095876

(51) Cl.Int./Int.Cl. *A61F 9/00* (2006.01),  
*A61N 1/30* (2006.01), *A61N 1/32* (2006.01)

(72) Inventeurs/Inventors:  
FOSCHINI, FULVIO, IT;  
ROY, PIERRE, FR;  
STAGNI, EDOARDO, IT;  
CAVALLO, GIOVANNI, IT;  
LUCIANI, GIULIO, IT

(73) Propriétaire/Owner:  
SOOFT ITALIA SPA, IT

(74) Agent: BERESKIN & PARR LLP/S.E.N.C.R.L.,S.R.L.

(54) Titre : DISPOSITIF POUR L'ADMINISTRATION PAR IONOPHORESE DE RIBOFLAVINE DANS LA CORNEE POUR LE TRAITEMENT DE KERATOCONE  
 (54) Title: DEVICE FOR CORNEAL DELIVERY OF RIBOFLAVIN BY IONTOPHORESIS FOR THE TREATMENT OF KERATOCONUS

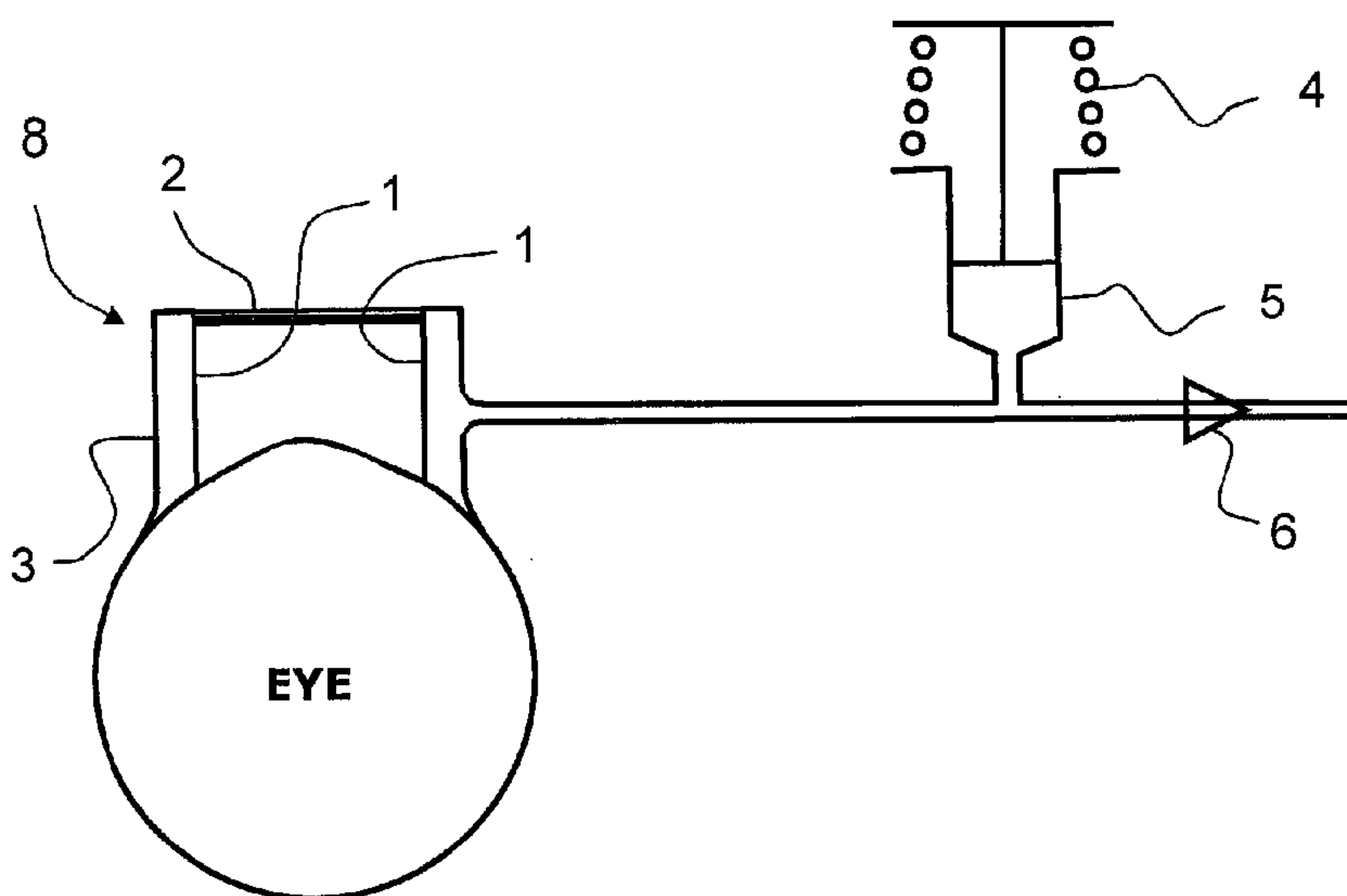

(57) Abrégé/Abstract:

An ocular iontophoresis device for delivering any ionized drug solution, such as riboflavin solution, to the cornea comprises, in combination: a reservoir (8) containing a riboflavin solution which is suitable to be merely positioned on the eye; an active electrode

(57) **Abrégé(suite)/Abstract(continued):**

(2) disposed in or on the reservoir (8); and a passive electrode suitable to be placed on the skin of the subject, elsewhere on the body, preferably in close vicinity of the eye, such as forehead, cheeks or neck; means (10) for irradiating the cornea surface with suitable light, such as UV light, for obtaining corneal' cross- linking after the delivering of drug or of Riboflavin; wherein said reservoir (8) and said active electrode (2) are transparent to UV light and/or visible light and/or IR light. Method for delivering any ionized drug solution, such as riboflavin solution, to the cornea for treatment of keratoconus or any other ectasic corneal disease, or for reinforcing corneal stromal structure by means of an ocular iontophoresis device according to preceding claims, providing the following steps : - positioning said iontophoretic device on the eye to be treated, the device comprising a reservoir containing the riboflavin solution; - driving the solution movement by a cathodic current applied for 0,5 to 5 min, at an intensity not higher than 2 mA; - irradiation, immediately after the end of the current application, of the cornea surface with an UV light for 5 to 30 min at a power of 3 to 30 mW/cm<sup>2</sup>; thereby obtaining the corneal cross-linking of the riboflavin.

(12) INTERNATIONAL APPLICATION PUBLISHED UNDER THE PATENT COOPERATION TREATY (PCT)

(19) World Intellectual Property  
Organization  
International Bureau(43) International Publication Date  
19 July 2012 (19.07.2012)(10) International Publication Number  
**WO 2012/095876 A1**

## (51) International Patent Classification:

*A61F 9/00* (2006.01)      *A61N 1/32* (2006.01)  
*A61N 1/30* (2006.01)

## (21) International Application Number:

PCT/IT2011/000009

## (22) International Filing Date:

12 January 2011 (12.01.2011)

## (25) Filing Language:

English

## (26) Publication Language:

English

(71) Applicant (for all designated States except US): **SOOFT ITALIA SPA** [IT/IT]; Contrada Molino, 17, I-63833 Montegiorgio (Fermo) (IT).

## (72) Inventors; and

(75) Inventors/Applicants (for US only): **FOSCHINI, Fulvio** [IT/IT]; Via Anassagora, 59, I-00124 Roma (IT). **ROY, Pierre** [FR/FR]; 8, passage du Plateau, F-75019 Paris (FR). **STAGNI, Edoardo** [IT/IT]; Via A. S. Fulci, 31/G, I-95127 Catania (IT). **CAVALLO, Giovanni** [IT/IT]; Via delle Tartane, 45, I-00122 Roma (IT). **LUCIANI, Giulio** [IT/IT]; Via Roma, 231, I-50012 Bagno a Ripoli (FI) (IT).

(74) Agents: **SARPI, Maurizio** et al.; Studio Ferrario, Via Collina, 36, I-00187 Rome (IT).

(81) Designated States (unless otherwise indicated, for every kind of national protection available): AE, AG, AL, AM, AO, AT, AU, AZ, BA, BB, BG, BH, BR, BW, BY, BZ, CA, CH, CL, CN, CO, CR, CU, CZ, DE, DK, DM, DO, DZ, EC, EE, EG, ES, FI, GB, GD, GE, GH, GM, GT, HN, HR, HU, ID, IL, IN, IS, JP, KE, KG, KM, KN, KP, KR, KZ, LA, LC, LK, LR, LS, LT, LU, LY, MA, MD, ME, MG, MK, MN, MW, MX, MY, MZ, NA, NG, NI, NO, NZ, OM, PE, PG, PH, PL, PT, RO, RS, RU, SC, SD, SE, SG, SK, SL, SM, ST, SV, SY, TH, TJ, TM, TN, TR, TT, TZ, UA, UG, US, UZ, VC, VN, ZA, ZM, ZW.

(84) Designated States (unless otherwise indicated, for every kind of regional protection available): ARIPO (BW, GH, GM, KE, LR, LS, MW, MZ, NA, SD, SL, SZ, TZ, UG, ZM, ZW), Eurasian (AM, AZ, BY, KG, KZ, MD, RU, TJ, TM), European (AL, AT, BE, BG, CH, CY, CZ, DE, DK, EE, ES, FI, FR, GB, GR, HR, HU, IE, IS, IT, LT, LU, LV, MC, MK, MT, NL, NO, PL, PT, RO, RS, SE, SI, SK, SM, TR), OAPI (BF, BJ, CF, CG, CI, CM, GA, GN, GQ, GW, ML, MR, NE, SN, TD, TG).

## Declarations under Rule 4.17:

— as to applicant's entitlement to apply for and be granted a patent (Rule 4.17(ii))

[Continued on next page]

(54) Title: DEVICE AND METHOD FOR CORNEAL DELIVERY OF RIBOFLAVIN BY IONTOPHORESIS FOR THE TREATMENT OF KERATOCONUS

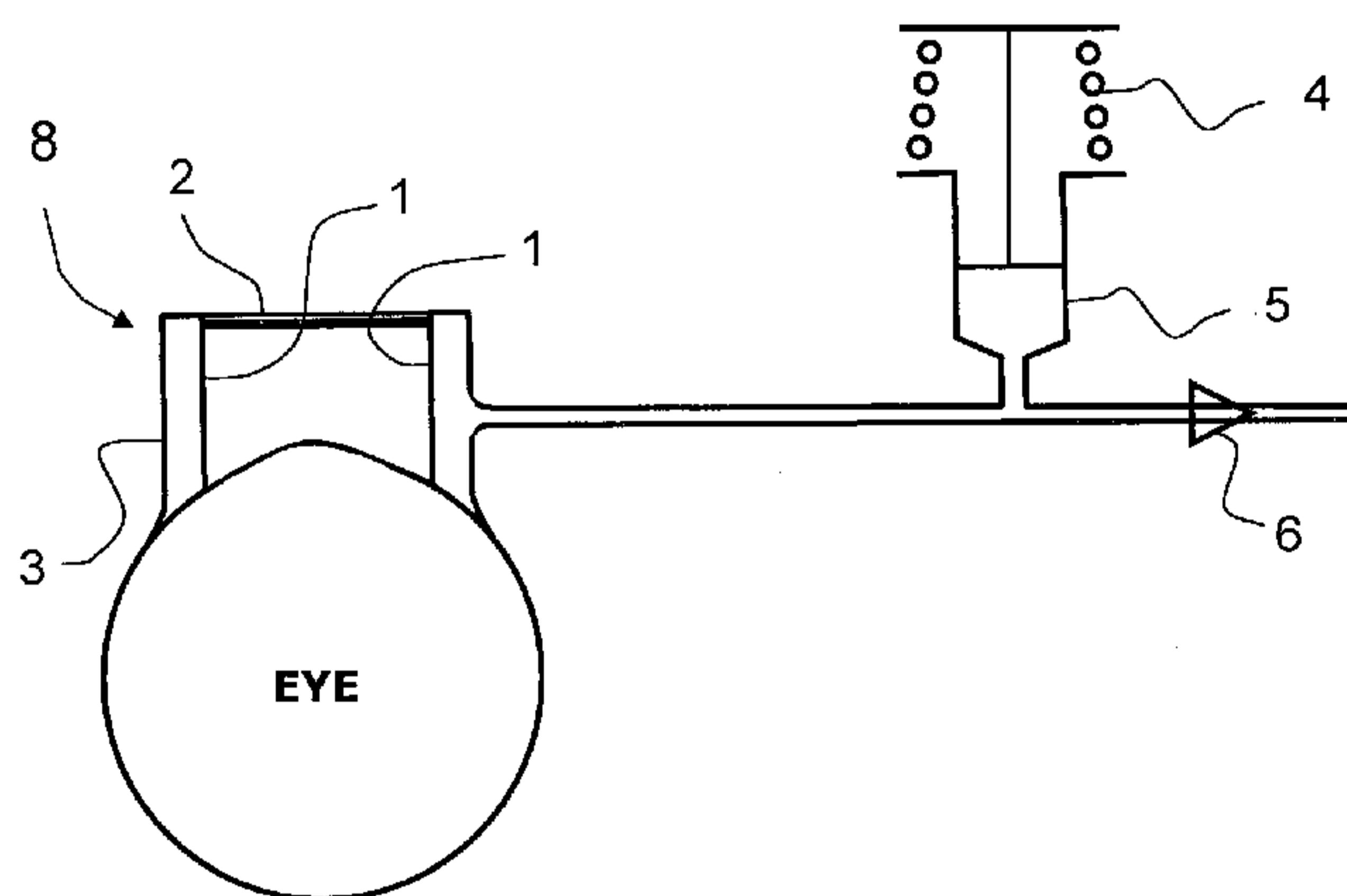

Fig. 1

(57) Abstract: An ocular iontophoresis device for delivering any ionized drug solution, such as riboflavin solution, to the cornea comprises, in combination: a reservoir (8) containing a riboflavin solution which is suitable to be merely positioned on the eye; an active electrode (2) disposed in or on the reservoir (8); and a passive electrode suitable to be placed on the skin of the subject, elsewhere on the body, preferably in close vicinity of the eye, such as forehead, cheeks or neck; means (10) for irradiating the cornea surface with suitable light, such as UV light, for obtaining corneal cross-linking after the delivering of drug or of Riboflavin; wherein said reservoir (8) and said active electrode (2) are transparent to UV light and/or visible light and/or IR light. Method for delivering any ionized drug solution, such as riboflavin solution, to the cornea for treatment of keratoconus or any other ectatic corneal disease, or for reinforcing corneal stromal structure by means of an ocular iontophoresis device according to preceding claims, providing the following steps: - positioning said iontophoretic device on the eye to be treated, the device comprising a reservoir containing the riboflavin solution; - driving the solution movement by a cathodic current applied for 0,5 to 5 min, at an intensity not higher than 2 mA; - irradiation, immediately after the end of the current application, of the cornea surface with an UV light for 5 to 30 min at a power of 3 to 30 mW/cm<sup>2</sup>; thereby obtaining the corneal cross-linking of the riboflavin.



WO 2012/095876 A1

**WO 2012/095876 A1** 

---

**Published:**

— *with international search report (Art. 21(3))*

DEVICE FOR CORNEAL DELIVERY OF RIBOFLAVIN BY  
IONTOPHORESIS FOR THE TREATMENT OF KERATOCONUS

\*\*\*\*\*

The present invention relates to a new device for iontophoresis to deliver ophthalmic compositions (in particular collyriums) preferably containing riboflavin, designed to imbibe the corneal stroma without having to proceed, in order to obtain said imbibition, to the removal of the corneal epithelium (de-epithelization) in the practice of the treatment of keratoconus, or other ectasic corneal disorders, by means of corneal cross-linking of suitable ophthalmic composition.

Keratoconus is a degenerative disease of the eye in which structural changes within the cornea cause it to thin and change to a more conical shape than its normal gradual curve. Keratoconus is a genetic disease consisting in a non-inflammatory progressive dystrophy affecting approximately 50 persons in every 100 000 each year, generally young people between 10 and 20 years of age. As disease frequency is higher amongst females, keratoconus etiology appears to be correlated to dysfunctions of endocrine glands (hypophysis and thyroid). It can affect both eyes in approximately 85% of cases and has an evolution that may vary from subject to subject.

Upon onset of this disease, there appears an irregular curvature that modifies the refractive power of the cornea, producing distortions of images and a confused close and distant vision. The patient complains in any case of a reduction of vision, above

all distant vision. The vision continues to regress irreversibly, with a consequent need for frequent change of spectacles, and for this reason it may at first be mistaken for a myopia associated to  
5 astigmatism.

On account of the congenital structural weakness of the corneal stroma due to said disease, after some years the cornea progressively tends to wear out and thin out towards the apex. There then occurs an  
10 irregular curvature of the cornea, which loses its spherical shape and assumes the characteristic cone shape (keratoconus).

Using the biomicroscope there may be noted a considerable reduction in the corneal thickness at the  
15 top of keratoconus. Over time, the top of keratoconus becomes opaque on account of an alteration in the nutriment of that part of the cornea, which in the most acute forms can present a corneal curvature of more than 62D and reach a corneal thickness of even 446  $\mu\text{m}$   
20 (normal central corneal thickness is 500 - 700  $\mu\text{m}$ ).

If the disease is neglected, the top can ulcerate with consequent perforation of the cornea; there appear pain, lacrimation and spasm of the eyelids. These changes of the cornea due to keratoconus produce an  
25 alteration in the disposition of the corneal protein, causing micro-scars that further distort the images and in some cases prevent passage of light, thus giving rise to a troublesome dazzling feeling, above all at times of the day when the sun is low on the horizon  
30 (sunrise and sunset).

As already mentioned, in order to correct the

vision it becomes necessary to change spectacles frequently. Only after the use of spectacles has proven unsatisfactory, in milder forms rigid contact lenses may be applied.

5           The real problem arises when the cornea affected by keratoconus undergoes considerable thinning or if cicatrization occurs following upon lacerations of the corneal surface, rendering necessary even surgical transplantation of the cornea (keratoplasty).

10           In 2002 so-called lamellar keratoplasty was introduced in Italy for the treatment of keratoconus, whereby, in practice, not the entire cornea is replaced, but only the outer thickness, i.e., the part affected by the disease.

15           However, already by 1997 in Germany, in the ophthalmic clinic of the Carl Gustaw Carus University of Dresda, a new safer and less invasive technique was developed, referred to as "corneal cross-linking" (CXL), which uses in particular riboflavin, activated by a UV  
20 laser; in 2005 this technique was tested also in Italy and is by now widely used successfully in various Italian eye clinics.

          Corneal cross-linking is a minimally-invasive method, which uses riboflavin activated by a UV laser  
25 (365-370 nm); the method is painless and is carried out in day-hospital. Cross-linking enables reinforcement of the structure of the cornea affected by keratoconus through the interweaving and increase in links (cross-linking) between the fibers of the corneal collagen.  
30 Clinical studies have proved CXL being able to reduce the astigmatism associated to keratoconus as well as to

slow down or arrest pathology evolution, thus avoiding the need for transplantation of the cornea. Also other disorders characterized by corneal ecstasia benefit from treatment using the cross-linking method.

5           Corneal cross-linking is usually carried out by applying a local corneal anaesthesia for making the abrasion of the corneal epithelium (de-epithelization) having a diameter of 8-9 mm. This is followed by a frequent instillation of a 0.1% riboflavin-based  
10 ophthalmic solution during 15 minutes, followed by irradiation with ultraviolet (UV-A) emitter during 30 minutes with instillation of riboflavin solution throughout the irradiation operation.

          Riboflavin (molecular weight 376, poorly soluble  
15 in water), more preferably riboflavin sodium phosphate (molecular weight 456, negatively charged), which is commonly used in corneal cross-linking, is a hydrophilic photosensitizing and photopolymerizing molecule with a poor capacity for diffusing through the  
20 epithelium and hence reaching the corneal stroma.

          It is therefore necessary to facilitate absorption thereof and complete impregnation of the corneal stroma before starting the irradiation with UV-A, by removing the corneal epithelium (de-epithelization). This  
25 procedure can create, albeit rarely, complications at a corneal level, pain, in addition to being a method that renders the task of the ophthalmologist more difficult.

          It would hence be desirable to improve the absorption of riboflavin, without having to remove the  
30 epithelium of the cornea, hence obtaining a noninvasive corneal cross-linking with elimination or reduction of

the anaesthesia and consequent fast healing without pain or possible complications.

Iontophoresis is known as a noninvasive method which allows the penetration of high concentration of ionized molecules, such as drugs, into living tissue driven by an electric current, in fact, applying a current to an ionizable substance increases its mobility across a biological surface. Three principle forces govern the flux caused by the current. The primary force is electrochemical repulsion, which propels species of the same charge through tissues. When an electric current passes through an aqueous solution containing electrolytes and a charged material (for example, the active pharmaceutical ingredient), several events occur:

- (1) the electrode generates ions,
- (2) the newly generated ions approach/collide with like charged particles (typically the drug being delivered), and
- (3) the electrorepulsion between the newly generated ions force the dissolved/suspended charged particles into and/or through the surface adjacent (tissue) to the electrode.

Continuous application of electrical current drives the active pharmaceutical ingredients significantly further into the tissues than is achieved with simple topical administration. The degree of iontophoresis is proportional to the applied current and the treatment time.

Iontophoresis occurs in water-based preparations, where ions can be readily generated by electrodes. Two types

of electrodes can be used to produce ions: (1) inert electrodes and (2) active electrodes.

Each type of electrode requires aqueous media containing electrolytes. Iontophoresis with an inert  
5 electrode is governed by the extent of water hydrolysis that an applied current can produce. The electrolysis reaction yields either hydroxide  $\text{OH}^-$  (cathodic) or hydronium  $\text{H}_3\text{O}^+$  (anodic) ions. Some formulations contain buffers, which can mitigate pH shifts caused by these  
10 ions. The presence of certain buffers introduces like charged ions that can compete with the drug product for ions generated electrolytically, which can decrease delivery of the drug product (and therefore increase the required application time). The electrical polarity  
15 of the drug delivery electrode is dependent on the chemical nature of the drug product, specifically its  $\text{pK}_a(\text{s})$ /isoelectric point and the initial dosing solution pH. It is primarily the electrochemical repulsion between the ions generated via electrolysis  
20 and the drug product charge that drives the drug product into tissues. Thus, iontophoresis offers a significant advantage over topical drug application, in that it increases drug absorption. The rate of drug delivery may be adjusted by varying the applied current  
25 by the person skilled in the art.

Due to the highly effective administration way of the iontophoretic process, ophthalmologist have long recognized the value of iontophoresis in the delivery of curative molecules to the eye and in the treatment  
30 of ocular pathologies, as not only the iontophoretic process permits a more rapid medicine application, but

it also allows a more localized and more highly concentrated application of drugs.

Several ocular iontophoretic devices have been developed, reported in the literature and known from  
5 the prior art.

The patent US 3,122,137 filed on 30.10.1961 describes an eye iontophoretic device consisting in a eye-glass frame shaped structure of non-conductive material and incorporating a current source adapted to  
10 be supported by the area around the eye orbit, in such a way the device cannot be in direct contact to the eye surface. Such device lacks of substance administration precision due to its rudimentary structural and design features.

15 The patent US 4,564,016 filed on 13.08.1984 describes an apparatus having a portion in engagement with the eye, consisting of a small application surface (1 mm diameter) applied on sclera and allowing very high current densities for focal iontophoresis.  
20 Such apparatus and the relative method are particularly adapted to introduce ionized drugs into the posterior portion of the eye across the cellular barriers protecting the retina such as the conjunctival epithelium and the pigment epithelium,  
25 but the current applied by this method are certainly toxic for the concerned tissues.

More recently, the patent US 6,319,240 filed on 25.05.1999 proposes an improvement of previous apparatus characterized by the presence of containment  
30 element, such as a sealed reservoir applied on sclera (with a semi-permeable membrane on application

surface) under the eyelid, that is filled with the medicament released under the influence of the electrical current.

The peculiar feature of the invention described in  
5 patent US 6,442,423 filed on 05.02.1999 is an applicator having a receiving portion holding a replaceable hydrogel carrier that is loaded with the drug. The solution provided by this invention ensures that the fluid drug solution is maintained in contact  
10 with the eye during the iontophoresis process, in fact handling of fluids to ensure their contact with eye surface is tricky, since fluids leak and form bubbles that reduce the efficacy of iontophoretic process.

15 The invention described in patent US 6,154,671 filed on 04.01.1999 relates to a device for transferring active pharmaceutical ingredients into the eyeball by iontophoresis characterized by an active electrode in the reservoir which is a surface  
20 electrode arranged facing eye tissues lying at the periphery of the cornea. In this case the transfer achieved by this system takes place through one or more eye tissues lying at the periphery of the cornea over a wide application area.

25 The matter of the invention disclosed by patent US 7,164,943 filed on 03.06.2004 relates an irritation-reducing ocular iontophoresis device provided by such features enabling to reduce application time on the eye and consequent irritation.

30 Furthermore, following technical advances in the iontophoresis field in the last decades occurred, in

particular concerning devices and apparatus, currently in research and development and mainly focused on several formulations suitable for delivery by ocular iontophoresis and methods of use thereof.

5           Use of ophthalmic compositions, possibly associated to riboflavin for corneal cross-linking in the treatment of keratoconus or other corneal ectasic disorders have been described and is matter-subject of the international patent application  
10 PCT/IT2009/000392, and relative priority patent application RM2008A00472. Such disclosed riboflavin based compounds facilitate epithelial absorption associated to corneal CXL, avoiding the resort to de-epithelization of the cornea, enabling a non-invasive  
15 corneal elimination or reduction of the anaesthesia and consequent fast healing without pain or possible complication for the patients.

          It is also known, from WO2007/025244, a kit cleaning system and method is disclosed. One  
20 embodiment of WO2007/0225244 has a photosensitizer solution supplied by a pressurized nozzle to the target site. Specific application of the solution is to an oral or skin surface target site. The photosensitizer solution is illuminated with  
25 sensitizing light creating reactive chemical species. Pressure and a solvent having an elevated concentration of oxygen or oxygen species improve the efficiency of the killing of pathogens. Methods of using the system within an oral cavity are also  
30 disclosed.

          In WO2007/0225244, the active electrode is not

transparent to UV light, visible light or IR light.

However, despite the more recent advances in the relevant field, there is still the need of more efficient delivery systems for releasing ophthalmic compositions to imbibe corneal stroma in the practice of corneal cross-linking for the treatment of keratoconus, and of suitable ophthalmic compositions for the treatment of keratoconus specifically formulated to be adapted to the more efficient corneal iontophoresis application as well.

Described in the following are new devices and new method utilizing iontophoresis to actively deliver a compound based on riboflavin into a mammalian eye. The method and device according to the present invention focus on developing riboflavin formulations and uses thereof to be employed in performing CXL to treat keratoconus.

Riboflavin sodium phosphate, commonly used in corneal cross-linking, is a low molecular weight, water soluble, negatively charged molecule; such set of features makes it potentially a suitable target for cathodic iontophoresis as shown in Figure 1.

As already indicated above, iontophoresis is substantially the promotion of the movement of a charged substance across a biological membrane by the application of a low electrical current forming an electrical field; it is the result of 3 transport mechanisms: chemical, electrical and electroosmotic fluxes which are explicated in the Nernst-Planck equation below:

$$\text{Flux}_{\text{total}} = \text{Flux}_{\text{passive}} + \text{Flux}_{\text{electric}} + \text{Flux}_{\text{osmotic}}$$

$$\text{Flux}_{\text{total}} = -D/(dc/dx) + (D.z.V.F.Ci)/(k.T) +/-C.u$$

5 Where:

- D Diffusion coefficient (characteristic of the biological membrane)

- dc/dx Concentration gradient

- z valence

10 - V Electrical field

- F Faraday's constant

- k Boltzmann's constant

- T Temperature

- Ci Ionized drug concentration

15 - C Drug concentration

- u convective flow of water

We assume, for simplicity, that the passive contribution is negligible (see Prausnitz "Permeability of Cornea, Sclera, and Conjunctiva: A Literature  
20 Analysis for Drug Delivery to the Eye", Journal of Pharmaceutical Sciences / 1479 Vol. 87, No. 12, December 1998 for experimental values).

-Electrorepulsion flow depends on charge (valence),  
25 electrical field V and concentration Ci, which are proportional to current density I and inversely proportional to ions mobility in fluid u (I = u.z.V.Ci). Ion mobility depend upon several factors as concentration, interaction between, ionic species  
30 themselves and between the ions and the solvent molecule, size of the charged drug molecule, polarity

of the solvent,... etc

-Electroosmotic flow occurs when an electrical field is applied across a membrane and produces bulk motion of the solvent itself that carries ionic or neutral species with the solvent stream. It is proportional to concentration of both ionic and neutral species of the drug.

From this, we can simplify Nersnt-Planck equation as follow:

$$\text{Flux}_{\text{total}} = + (D.I.C_i)/(u.k.T) +/- C.u$$

One of the concern is the electroosmotic flow direction and the relative importance of the flow as compared with repulsion and passive flow.

The electroosmotic flow is in the direction of the membrane charge's counter-ions. At physiological pH (7.4), skin, like most of the biological membranes including cornea and sclera is negatively charged. Therefore, the electroosmotic flow enhance anodic (+) delivery of positively charged drug while cathodic (-) of negatively charged drug delivery is retarded.

At low pH, over pI, isoelectric value of the cornea and sclera considered to be 4 (see Huang et al, Biophysical journal 1999) and comparable to skin surface's pI values that ranges from 3 to 4, the surface turns positive and electroosmotic flux reverses. That explains the importance of buffering, which besides the fact it protects conjunctival and corneal damage (eye can tolerate a fairly wide pH range

and ophthalmic solutions may range from pH 4.5 - 11.5, but the useful range to prevent corneal damage is 6.5 to 8.5), but it keeps the relative contribution of each flow at a constant level. It also guaranties a stable  
5 number of ionic species in the solution if the duration of applied current is kept short.

In view of the above, it is an object of the present invention to provide an innovative iontophoresis device for delivering a specific product  
10 formulation adapted to corneal imbibition associated to CXL and subsequent UV treatment for obtaining cross-linking of corneal stroma proteins.

Another object of the invention is to propose an ocular iontophoresis method using said innovative  
15 device with an optimized riboflavin solution in a form that is more easily ionizable and such as to maximize its introduction through cornea by iontophoresis and to dramatically reduce the needed treatment time.

This ocular iontophoretic based approach is a  
20 novel, non-invasive, and a much more efficient method which can lead to better results than those achieved by classical riboflavin administration ways to introduce riboflavin to the cornea to be treated by CXL. Remarkably, as the administration time is significantly  
25 reduced due to increased transfer efficiency, the procedure results much more comfortable for patients.

Thus, in a first aspect the herewith presented invention is an ocular iontophoresis device for delivering riboflavin solution to the cornea, the  
30 device comprising:

- a reservoir containing the riboflavin solution

which is suitable to be positioned on the eye;

- an active electrode disposed in the reservoir; and
- a passive electrode.

The passive electrode is placed on the skin of the  
5 subject, elsewhere on the body, preferably in close  
vicinity of the eye, such as forehead, cheeks or neck.

There is also provided a method of treatment of  
keratoconus by ocular iontophoresis, wherein in order  
to deliver riboflavin solution to perform corneal  
10 cross-linking, a iontophoretic device is positioned on  
the eye, the device comprising a reservoir containing  
the riboflavin solution with an initial pH around 4-5,  
without buffer or a minimal buffer content, the  
reservoir being suitable to be positioned on the eye,  
15 and having an active electrode placed in the reservoir,  
and a passive electrode; the solution movement is  
driven by a cathodic current applied for 0,5 to 5 min,  
preferably 1 to 3 min, at an intensity of 2 mA,  
preferably 1 mA

20 Furthermore, in a third aspect there is provided  
an ocular iontophoresis device comprising:

a) a reservoir containing the riboflavin solution,  
the reservoir extending along a surface intended to  
cover a portion of the eyeball surface and provided  
25 with a flushing element to remove excess of riboflavin  
solution at the end of the iontophoresis procedure,

b) an active electrode structure made of material  
transparent to UV light associated with the reservoir  
so as to supply an electric field directed through the  
30 riboflavin solution and toward a surface of the eye  
wherein the riboflavin solution is transcorneally

delivered through the surface of the eye by iontophoresis, the material transparent allowing the irradiation of the riboflavin solution immediately following current application.

5

#### BRIEF DESCRIPTION OF THE DRAWINGS

Figure 1 schematically shows a preferred embodiment of the present invention;

10

Figure 2 shows a detail of fig. 1;

Figures 3A, 3B and 3C show, respectively, three different structures for the active electrode;

15

Figure 4 shows a particular embodiment of the present invention wherein the electrode structure has as a mesh or surface comprising a sufficient number of holes so the electrode is semi-transparent to UV at the appropriate wavelength of 365 nm;

20

Figure 5 shows another particular embodiment wherein the electrode structure has an annulus shape, having in its center a divergent transparent lens allowing an illumination surface of diameter 8 mm at a distance of 10 mm;

25

Figure 6 shows a further particular embodiment wherein the electrode structure is a disk, surrounded with a divergent annular lens allowing an illumination surface of diameter 8mm at a distance of 10 mm; and

30

Figure 7 shows a variant of the present invention wherein the electrode structure is a disk of diameter 10 mm, surrounded with a divergent annular lens allowing an illumination surface of diameter 8mm at a distance of 10mm, the walls of the device having an angle of alpha, which is between 60° and 20°,

preferably between 30° and 20° to avoid excessive incident light refraction.

According to the present invention the electrode structure is made of electrically conductive material, such as stainless steel, ferrous materials, non-ferrous materials such as aluminum, copper, tungsten, silver, gold, carbon, conductive polymers (naturally conductive or loaded with conductive particles).

Electrode can be either made of a mesh, a plate pierced with pinholes or any semi-continuous structure with holes, large enough to allow UV light to be transmitted.

Ideally, the electrode can be made of a continuous transparent plastic part, plated on the reservoir side with a mesh or with thin lines of conductive materials, that can be printed using serigraphy or pad-printing techniques.

Electrode is connected to a continuous current generator delivering a continuous 0,5 to 2 mA current at a voltage adapted to the body and riboflavin solution impedance. The generator is in turn connected to a return electrode placed elsewhere on the body to close the electrical circuit.

The device electrode is ideally placed at a distance of 1 to 6 mm to the central cornea, or preferably at a distance of 4 to 5 mm.

From the experimentation, it has be noted that, during the iontophoresis application time, the pH increases only at the vicinity of the electrode and therefore away from the eye surface. As a consequence, according to the present invention, the value of pH

shift at the eye surface can be controlled by modifying the distance of the electrode from the eye surface.

The distance of the electrode from the eye surface is increased for a longer iontophoretic application time, thus minimizing the increase of pH at the eye surface.

In a particular embodiment of the present invention the electrode structure has as a mesh or surface comprising a sufficient number of holes so the electrode is semi-transparent to UV at the appropriate wavelength of 365 nm (Fig. 4).

In another particular embodiment the electrode structure has an annulus shape, having in its center a divergent transparent lens allowing an illumination surface of diameter 8mm at a distance of 10 mm (Fig. 5).

In another particular embodiment the electrode structure is a disk, surrounded with a divergent annular lens allowing an illumination surface of diameter 8mm at a distance of 10 mm (Fig. 6).

In another variant the electrode structure is a disk of diameter 10 mm, surrounded with a divergent annular lens allowing an illumination surface of diameter 8mm at a distance of 10mm, the walls of the device having an angle of alpha, which is between 60° and 20°, preferably between 30° and 20° to avoid excessive incident light refraction (Fig. 7).

According to the present invention the iontophoresis device has circular shape with inside diameter of 8-12 mm, preferably 10 mm, made of non-electrically conductive materials, such as plastic.

The proximal side of the device, that in contact with the corneal or limbus at the periphery of the cornea, can be made of a different material, such as an elastomeric material, this feature allows to  
5 accomodate small changes in eye geometry so it can fit perfectly on eye's surface avoiding fluid leaks.

At the periphery of the device structure, a second circular wall with an open end on eye's side and a close end on electrode side and means to form a light  
10 vacuum in the outer annular chamber (see Fig. 1).

The distal surface of this annular chamber corresponds to the pars plana area of the eye, with an internal diameter of 12 mm and an external diameter of 18 mm, preferably 16 mm, or more preferably 14 mm.

15 When device in place on the eye, a light vacuum is set in this chamber to hold the device in place during application.

#### ELECTRODE STRUCTURE:

Same plastic transparent material, such as  
20 polymethacrylate, polycarbonate, cycloolefin, polymethylpentene, polystyren is used to shape a divergent or convergent lens allowing central corneal illumination of a diameter 8 to 10 mm.

Lens can be placed centrally or peripherally on  
25 the electrode, or around the electrode. When the lens is placed around the electrode, the electrode surface is maximalized.

The device structure with its walls and the electrode forming a reservoir, with an open end being  
30 in contact with the eye and a closed end where the electrode is located.

Advantageously, walls of the device can be made with a non-transparent material at the given treatment wavelength to avoid irradiation of the periphery of the cornea or limbal structure.

5 The application time of the device on the cornea consist in 0,5 to 5 min application of current, immediately followed by UV irradiation time of 5 to 30 min at a power of 3 to 30 mW/cm<sup>2</sup>

10 Before application of light, the Riboflavin content in the reservoir is purged.

Finally, it is useful to point out that the device according to the present invention can be applied to any ionized solution, positively or negatively charged, that would induce collagen cross-linking upon  
15 application of UV light and/or visible light and/or IR light.

LIST OF REFERENCES IN THE DRAWINGS:

1. inner wall
2. active electrode
- 20 3. annular chamber
4. spring
5. syringe
6. non return valve
7. transparent plastic
- 25 8. reservoir
9. means for irradiating the cornea surface
10. lens

**WHAT IS CLAIMED IS:**

1. An ocular iontophoresis device for delivering an ionized drug solution to a cornea, comprising, in combination:

- a reservoir comprising at least one of a wall for containing the ionized drug solution which is suitable to be positioned on an eye;
- an active electrode disposed in or on the reservoir;
- a passive electrode suitable to be placed on a skin of the subject, elsewhere on the body;
- means for irradiating the cornea surface with suitable light for obtaining corneal cross-linking after delivery of the drug;

wherein said reservoir and said active electrode are transparent to at least one or more of UV light, visible light and IR light.

2. The device according to claim 1, wherein the passive electrode is suitable to be placed on a skin of the subject, in close vicinity of the eye.

3. The device according to claim 1, wherein the passive electrode is suitable to be placed on a skin of the subject, on forehead, cheeks or neck.

4. The device according to any one of claims 1 to 3, wherein the means for irradiating the cornea surface with suitable light comprises UV light.

5. The device according to any one of claims 1 to 4, wherein the device comprises means for providing a cathodic current having an intensity of about 2 mA.

6. The device according to any one of claims 1 to 4, wherein the device comprises means for providing a cathodic current having an intensity of about 1 mA.

7. The device according to any one of claims 1 to 6, wherein the device comprises means for providing a cathodic current for about 0.5 to about 5 min.

8. The device according to any one of claims 1 to 6, wherein the device comprises means for providing a cathodic current for about about 1 to about 3 min.

9. The device according to any one of claims 1 to 8, wherein said reservoir containing the ionized drug solution extends along a surface covering a portion of the eyeball surface and is provided with a flushing element to remove excess of the ionized drug solution at the end of an iontophoresis procedure.
10. The device according to claim 1, wherein said active electrode has a structure made of material transparent to UV light associated with the reservoir for supplying an electric field directed through the ionized drug solution and toward a surface of the eye wherein the ionized drug solution is suitable for transcorneally delivered through the surface of the eye by iontophoresis, the transparent material being suitable to allow the irradiation of the ionized drug solution immediately following current application.
11. The device according to claim 1, wherein the active electrode has a discontinuous structure made of electrically conductive material or conductive polymers naturally conductive or loaded with conductive particles.
12. The device according to claim 1, wherein the active electrode has a discontinuous structure made of electrically conductive material chosen from stainless steel, ferrous materials, non-ferrous materials aluminium, copper, tungsten, silver, gold and carbon.
13. The device according to any one of claims 1 to 12, wherein the active electrode is made of a mesh, or a pierced plate or any semi-continuous structure with openings large enough to allow UV light to be transmitted.
14. The device according to claim 11 or 12, is provided with a plated mesh or with plated thin lines of conductive materials.
15. The device according to claim 11 or 12, wherein the active electrode is constituted by a continuous transparent plastic part which, on the reservoir side, is provided with a plated mesh or with plated thin lines of conductive materials that is printed using serigraphy or pad-printing techniques.
16. The device according to any one of claims 1 to 15, wherein said the active electrode is connected to a continuous current generator delivering a continuous about 0.5 to about 2 mA current at a voltage adapted to the body and ionized drug solution impedance; said generator

being in turn connected to said return passive electrode placed elsewhere on the body to close the electrical circuit.

17. The device according to claim 1, wherein the device is placed at a distance of about 1 to about 6 mm to the central cornea.

18. The device according to claim 1, wherein the device is placed at a distance of about 4 to about 5 mm.

19. The device according to claim 1, wherein the active electrode is a mesh or a surface comprising a sufficient number of holes so the active electrode is semi-transparent to UV at the appropriate wavelength of about 365 nm.

20. The device according to claim 1, wherein the active electrode has an annulus shape having in its centre a divergent transparent lens allowing an illumination surface of diameter about 8 mm at a distance of about 10 mm.

21. The device according to claim 1, wherein the active electrode is a disk, surrounded with a divergent annular lens allowing an illumination surface of diameter about 8 mm at a distance of about 10 mm; the lens being placed around the active electrode so as to not impede the electrode surface.

22. The device according to claim 1, wherein the active electrode is a disk of diameter about 10 mm, surrounded with a divergent annular lens allowing an illumination surface of diameter about 8 mm at a distance of about 10 mm, the device having walls placed with an angle of alpha.

23. The device according to claim 1, wherein the device has circular shape with inside diameter of about 8 to about 12 mm, made of nonelectrically conductive plastic material.

24. The device according to claim 1, wherein the device has circular shape with inside diameter of about 10 mm, made of nonelectrically conductive plastic material.

25. The device according to claim 1, wherein the proximal side of the device is suitable to be placed in contact with the corneal or limbus at a periphery of the cornea; said proximal side

- being made of a different material, thereby accommodating small changes in eye geometry so said proximal side can fit on the eye's surface and avoid fluid leaks.
26. The device according to claim 1, wherein the proximal side of the device is suitable to be placed in contact with the corneal or limbus at a periphery of the cornea; said proximal side being made of a different material that is an elastomeric material, thereby accommodating small changes in eye geometry so said proximal side can fit on the eye's surface and avoid fluid leaks.
27. The device according to claim 1, wherein the reservoir has an annular shape and at a periphery of the device there is provided a second circular wall having an open end on eye's side and a closed end on electrode side, so as to form an outer annular chamber for the reservoir; being further provided means to form a vacuum in the outer annular chamber suitable for holding the device in place on the eye during application.
28. The device according to any one of claims 1 to 27, wherein a distal surface of said annular chamber corresponds to the pars plana area of the eye, with an internal diameter of about 12 mm and an external diameter of about 18 mm.
29. The device according to any one of claims 1 to 27, wherein a distal surface of said annular chamber corresponds to the pars plana area of the eye, with an internal diameter of about 12 mm and an external diameter of about 16 mm.
30. The device according to any one of claims 1 to 27, wherein a distal surface of said annular chamber corresponds to the pars plana area of the eye, with an internal diameter of about 12 mm and an external diameter of about 14 mm.
31. The device according to any one of claims 20 to 22, wherein a plastic transparent material is used to shape a divergent or convergent lens, wherein the divergent or convergent lens allows a central corneal illumination of a diameter of about 8 to about 10 mm.
32. The device according to claim 31, wherein the plastic transparent material is chosen from polymethacrylate, polycarbonate, cycloolefin, polymethylpentene and polystyrene.

33. The device according to claim 1, wherein the device has a structure with walls that, together with the active electrode, form the reservoir with an open end being in contact with the eye and a closed end where the active electrode is located.

34. The device according to claim 1, wherein the device is provided with means for purging the reservoir of its content before the application of UV light or of other suitable light for cross-linking.

35. The device according to claim 22, wherein angle alpha is between about  $60^\circ$  and about  $20^\circ$  to avoid excessive incident light refraction.

36. The device according to claim 22, wherein angle alpha is between about  $30^\circ$  and about  $20^\circ$  to avoid excessive incident light refraction.

37. The device according to claim 1, wherein the distance between the active electrode and the eye surface is modifiable to control the pH on the eye, since during iontophoresis the pH increases only in proximity of the active electrode and therefore away from the eye surface.

38. The device according to claim 1, wherein the at least one of wall of the device comprises a non-transparent material at the given treatment wavelength to avoid irradiation of a periphery of the cornea or limbal structure.

39. The device according to any one of claims 1 to 38, wherein the ionized drug solution is a riboflavin solution.

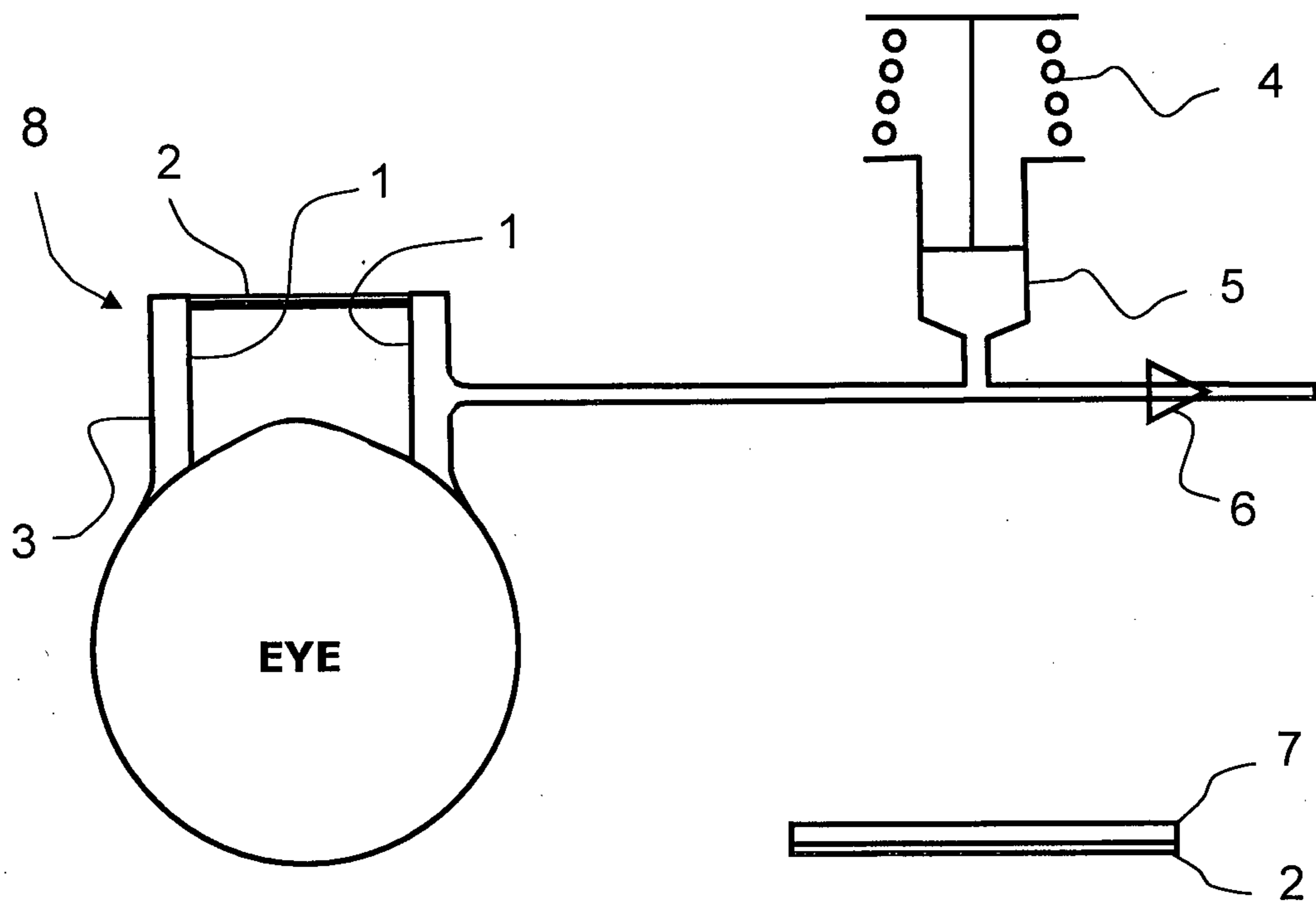

Fig. 1

Fig. 2

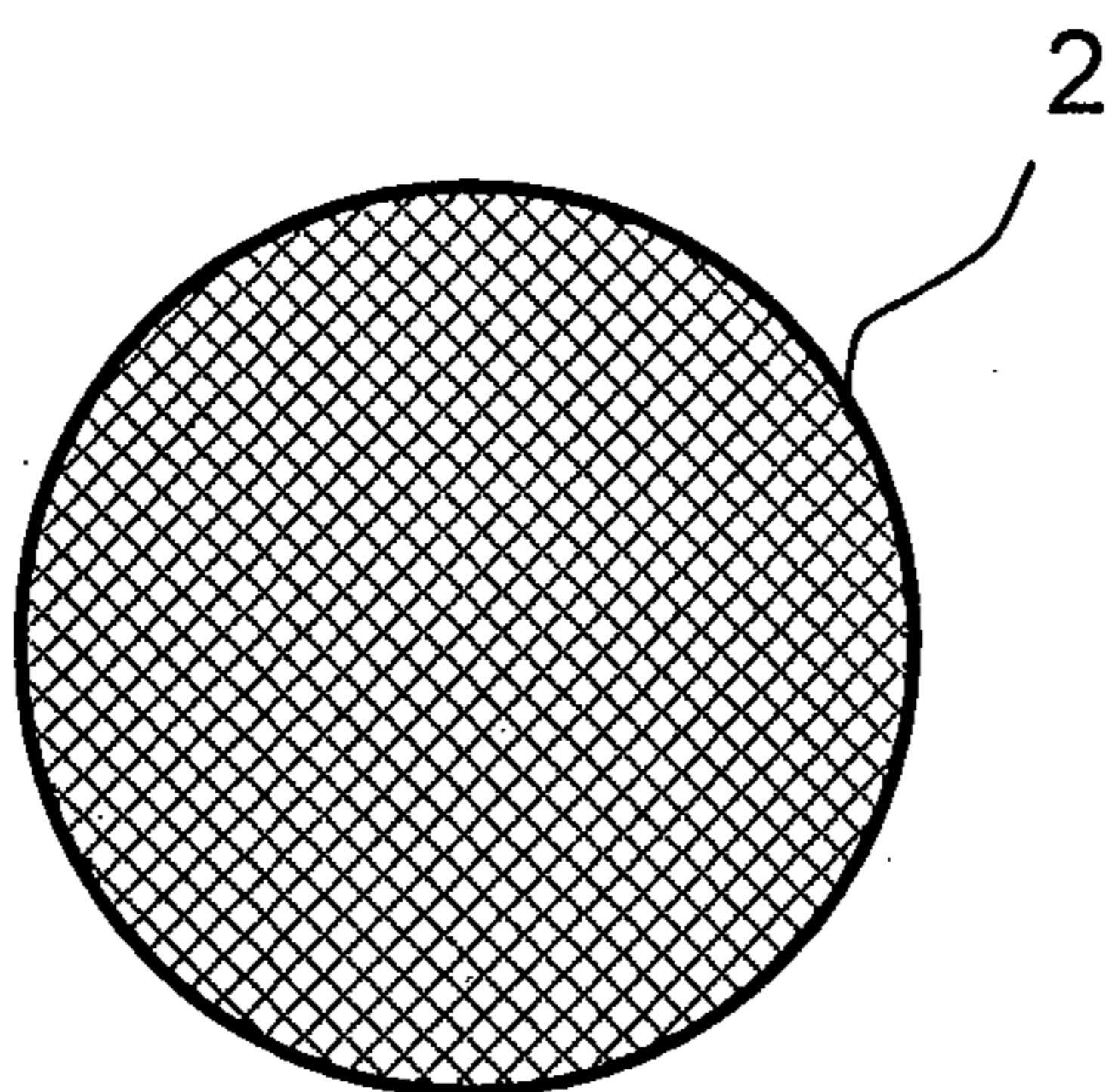

Fig. 3A

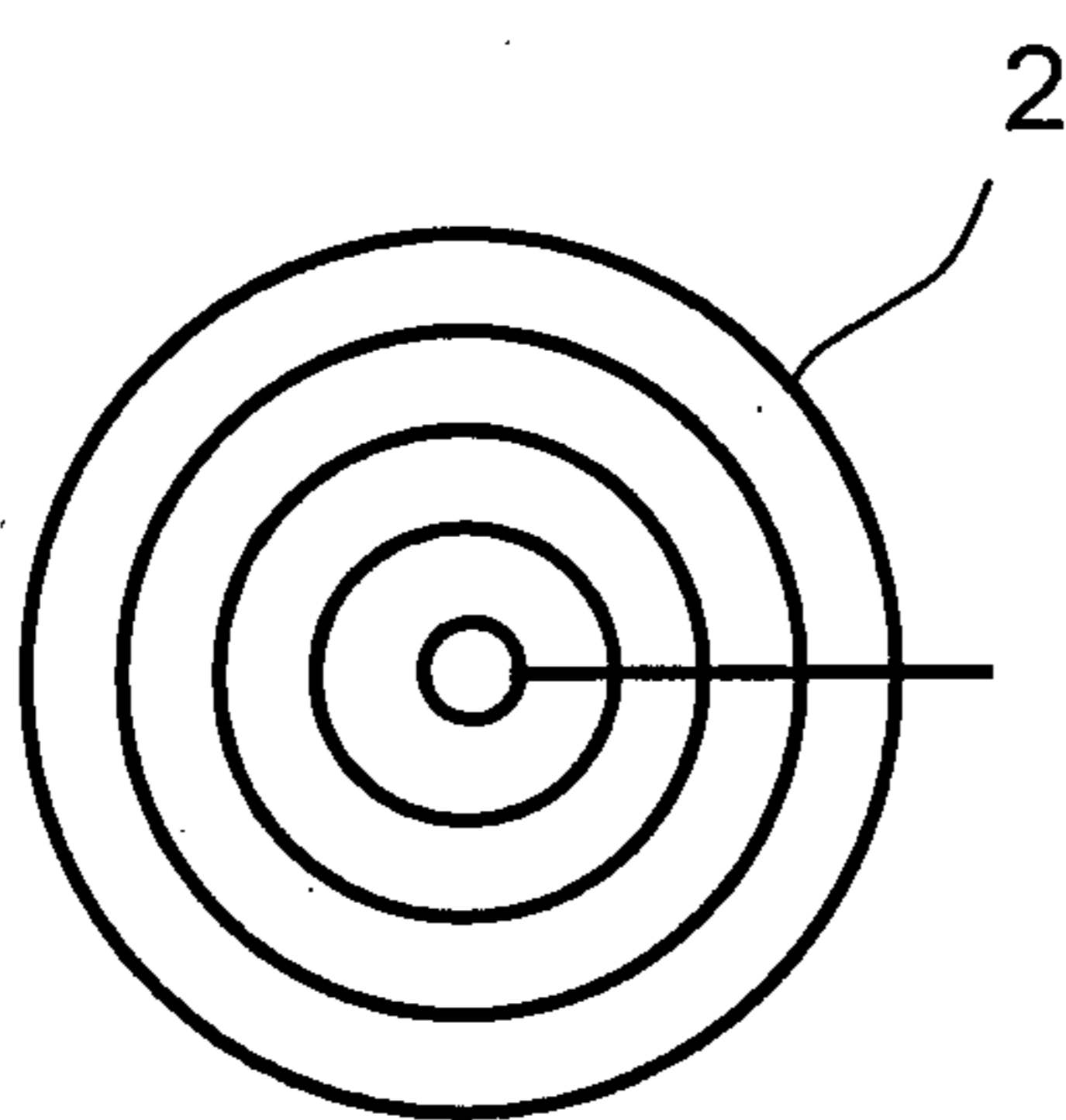

Fig. 3B

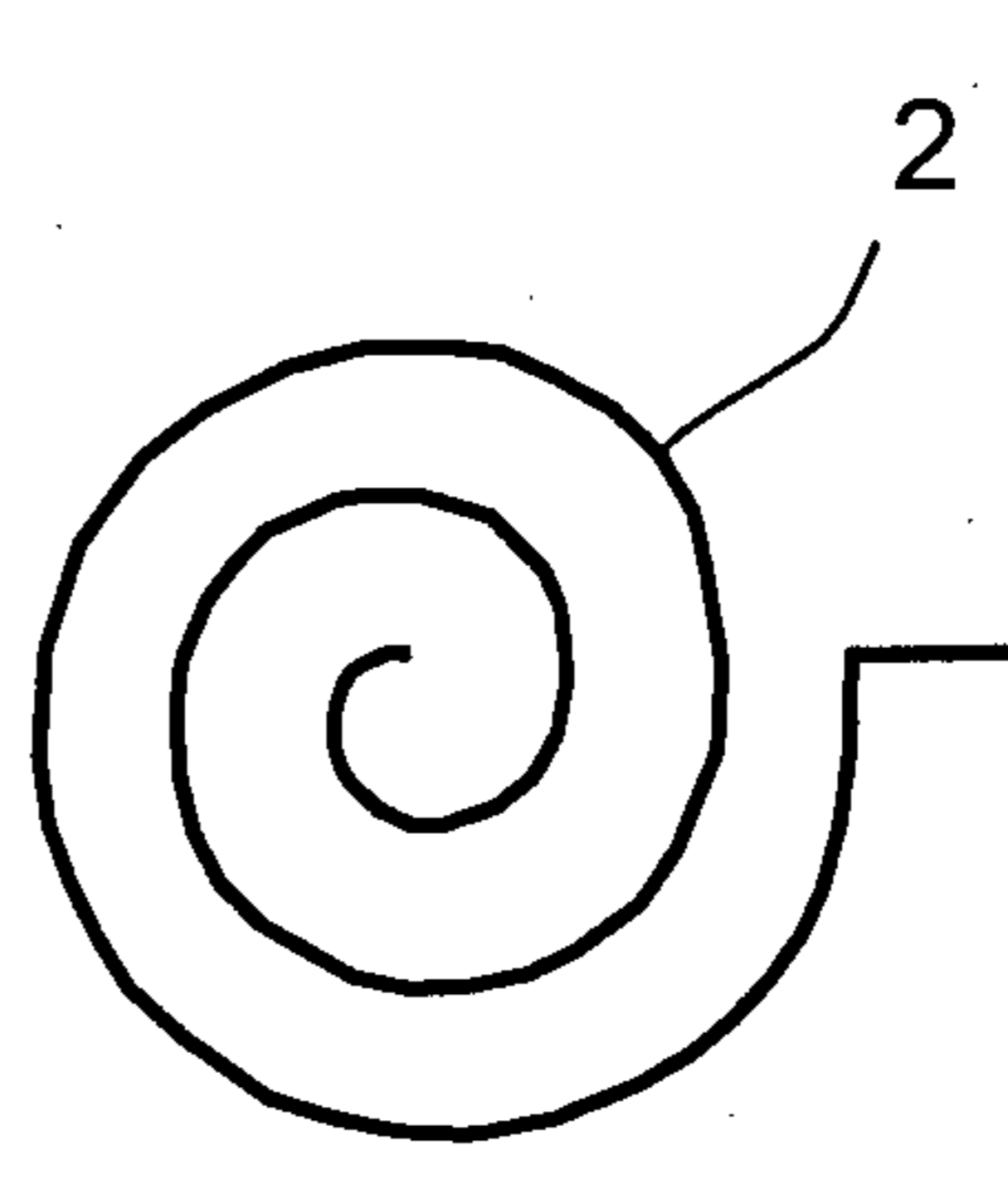

Fig. 3C

2 / 3

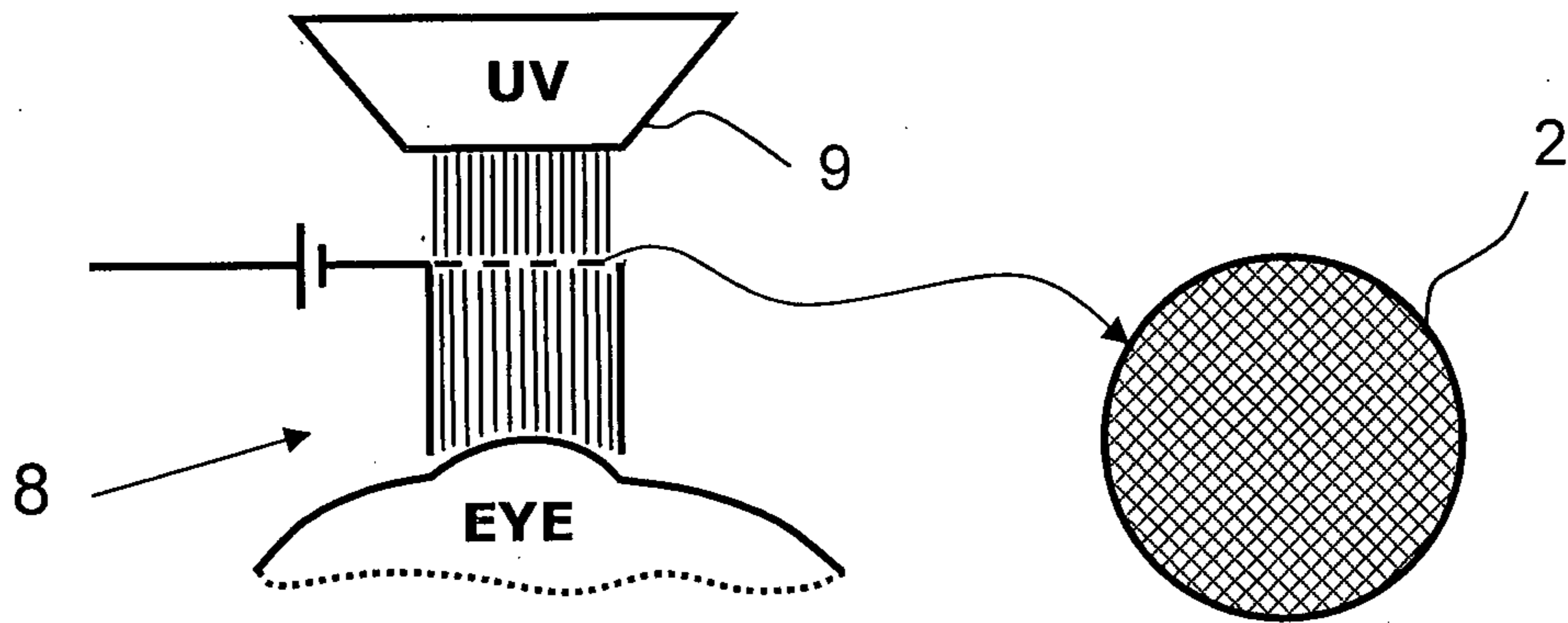

Fig. 4

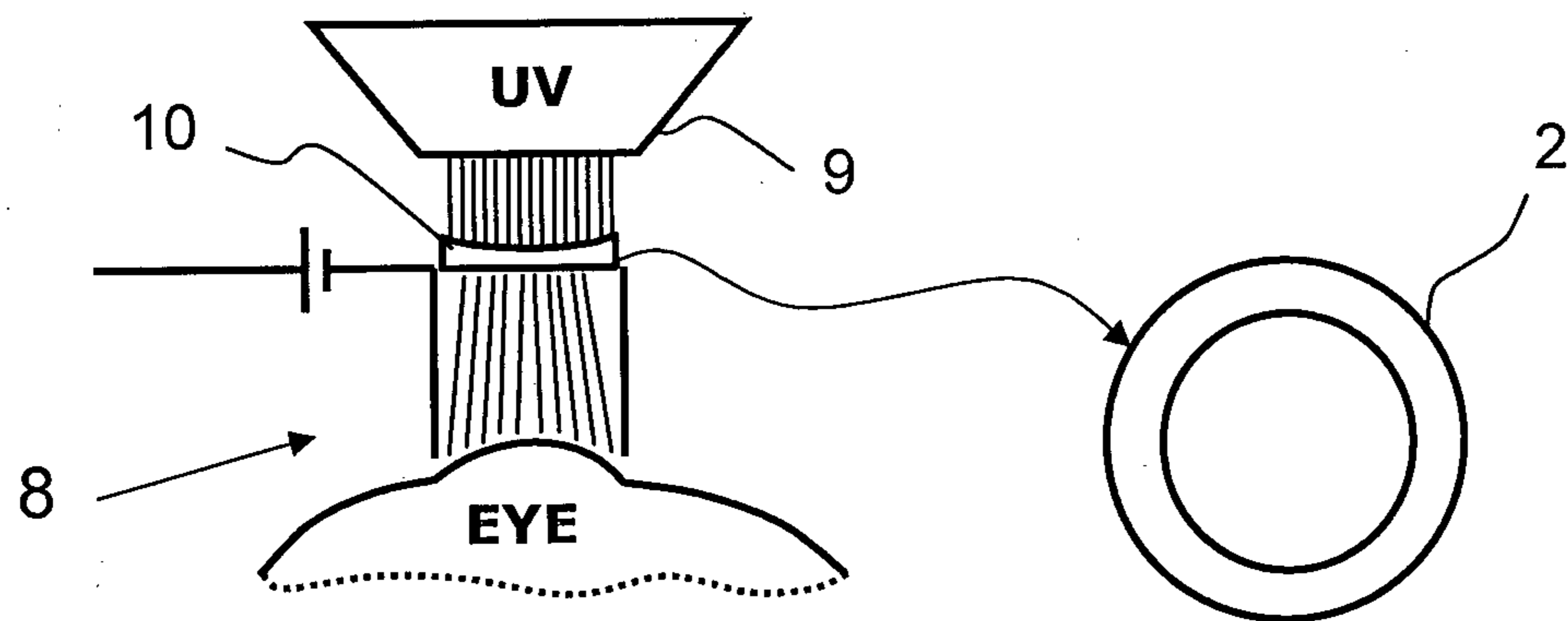
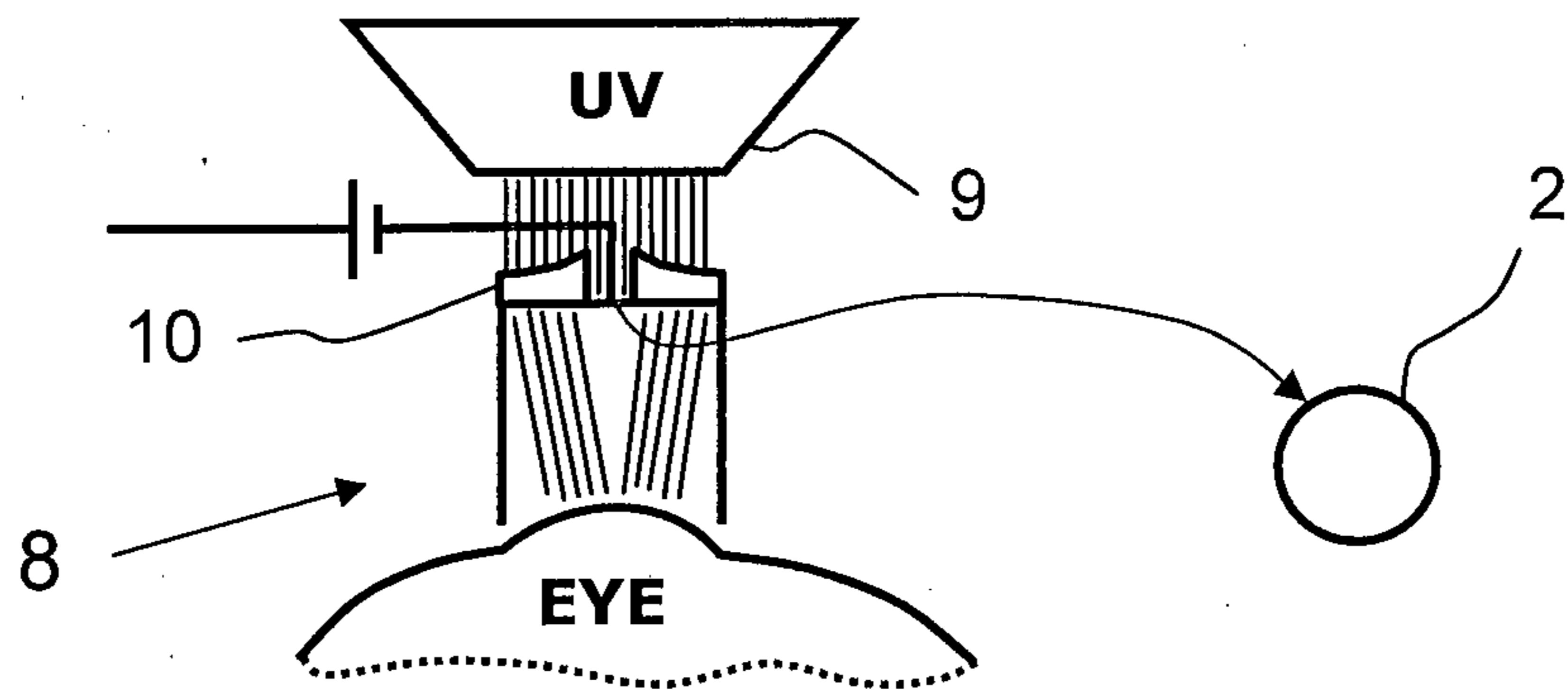
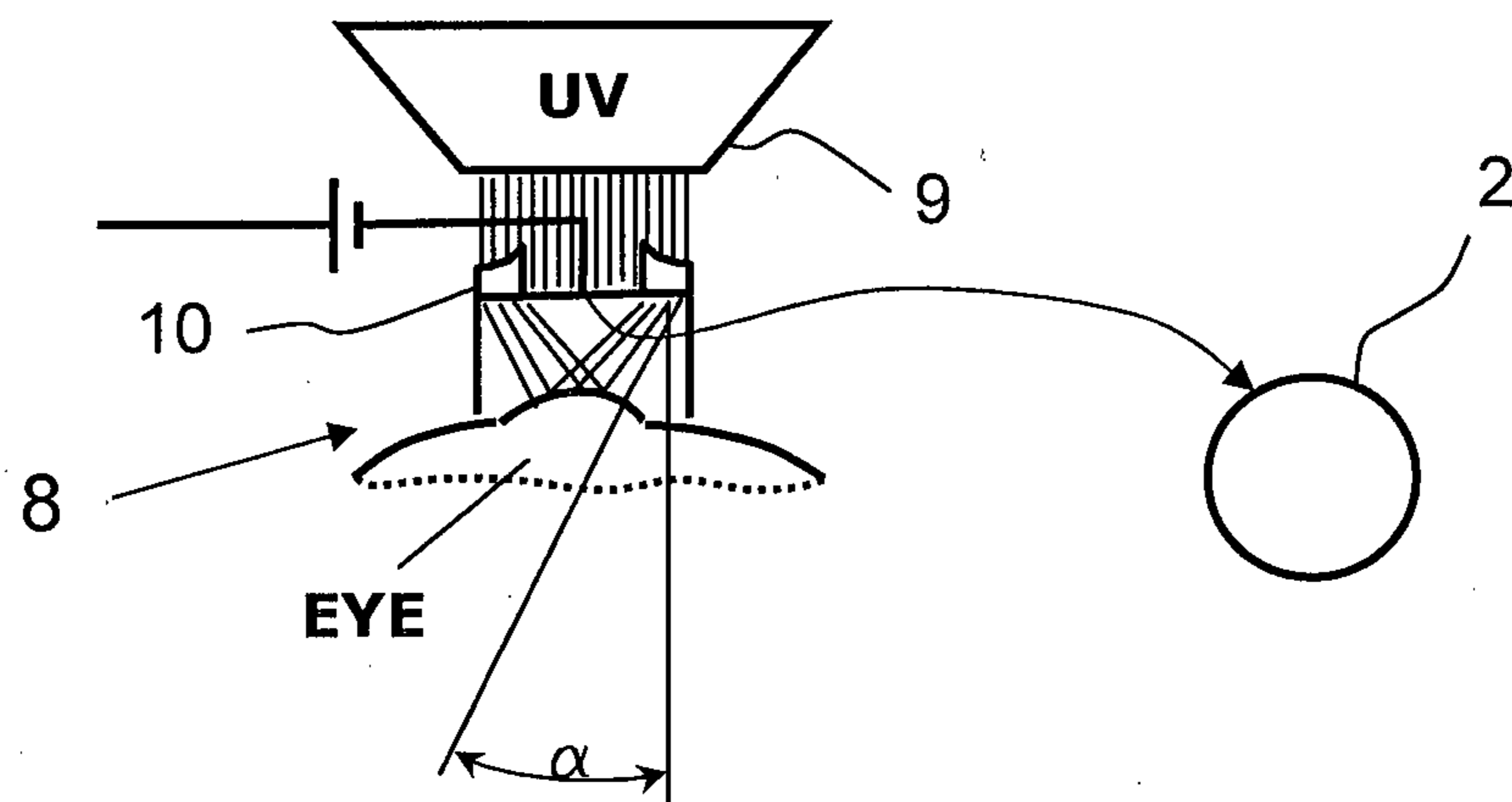

Fig. 5

3 / 3

Fig. 6Fig. 7

