

J. PROCK,
 MACHINE FOR AUTOMATICALLY DEPOSITING ARTICLES IN PACKAGES.
 APPLICATION FILED JUNE 7, 1916.

1,298,389.

Patented Mar. 25, 1919.

3 SHEETS—SHEET 1.

Fig. 1.

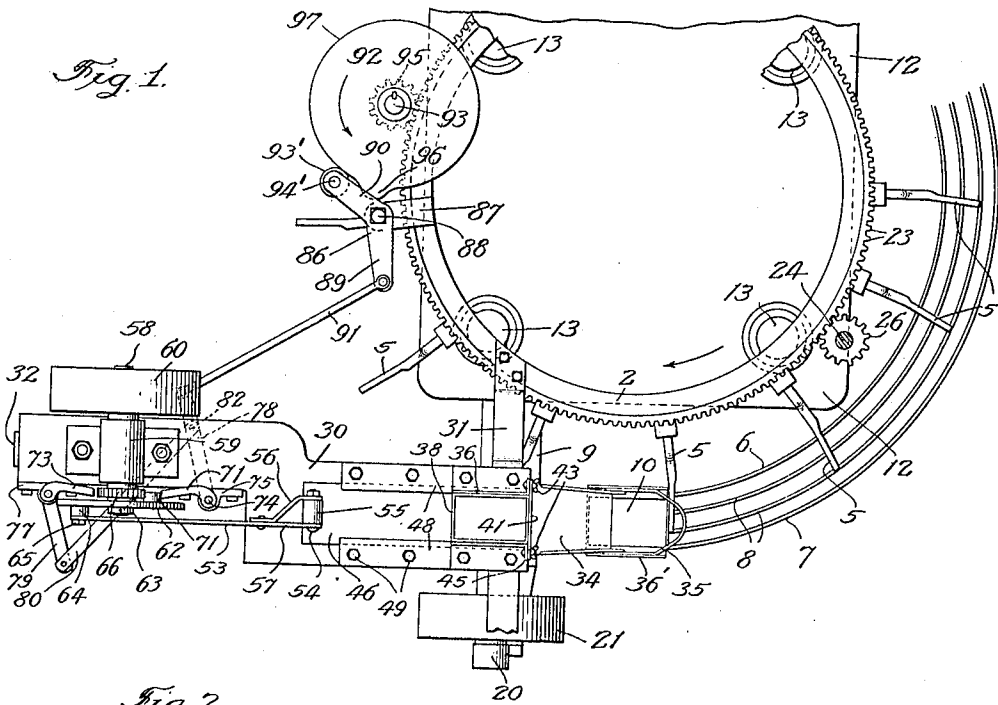

Fig. 2.

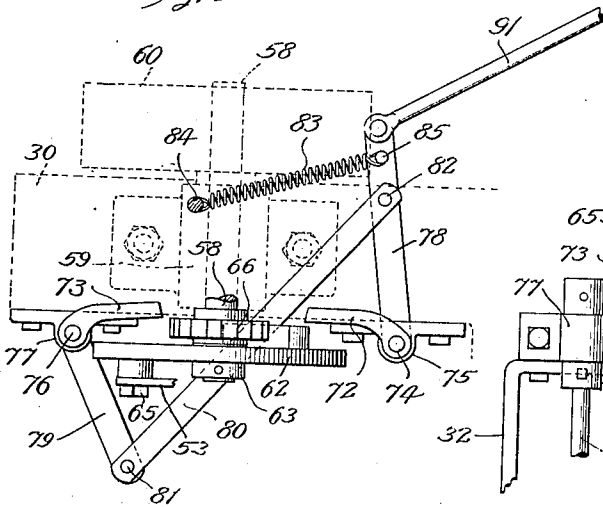
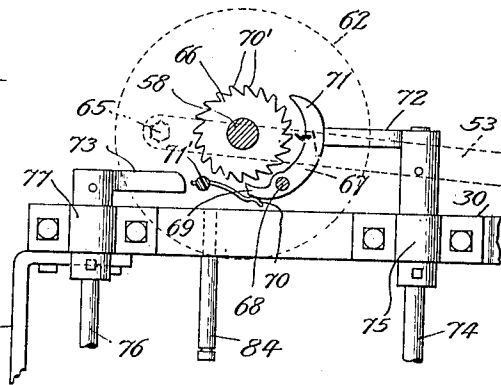

Fig. 3.



Witnesses:

E. O. Gaylord,
Chas. H. Buell.

Inventor:

Joseph Prock,
 By *Harry Irwin Proctor*
 Atty.

J. PROCK.
 MACHINE FOR AUTOMATICALLY DEPOSITING ARTICLES IN PACKAGES.
 APPLICATION FILED JUNE 7, 1916.

1,298,389.

Patented Mar. 25, 1919.

3 SHEETS—SHEET 3.

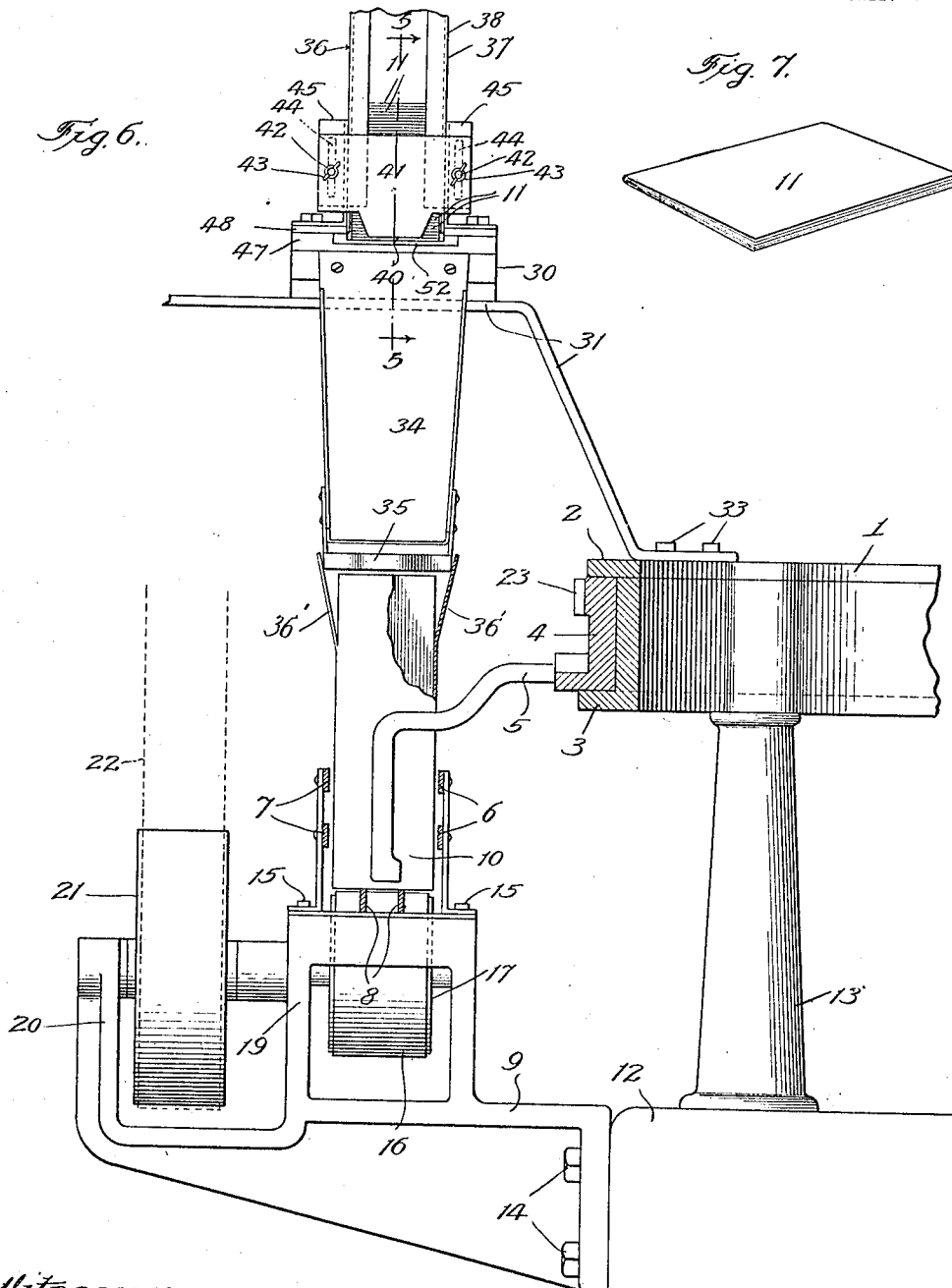
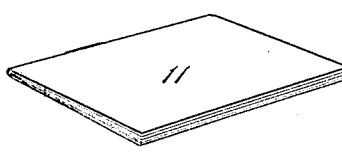

Fig. 6.

Fig. 7.



Witnesses:
Wm. Taylor
Chas. H. Bull

Inventor:
 Joseph Prock,
 By *Harry Irwin Promer*,
 Atty.

UNITED STATES PATENT OFFICE.

JOSEPH PROCK, OF CHICAGO, ILLINOIS, ASSIGNOR TO PACIFIC COAST BORAX COMPANY,
OF NEW YORK, N. Y., A CORPORATION OF NEVADA.

MACHINE FOR AUTOMATICALLY DEPOSITING ARTICLES IN PACKAGES.

1,298,389.

Specification of Letters Patent. Patented Mar. 25, 1919.

Application filed June 7, 1916. Serial No. 102,329.

To all whom it may concern:

Be it known that I, JOSEPH PROCK, a citizen of the United States, residing in Chicago, in the county of Cook and State of Illinois, have invented certain new and useful Improvements in Machines for Automatically Depositing Articles in Packages, of which the following is a specification.

This invention relates to that class of machines for automatically depositing articles in packages, which are adapted to enable books or similar articles to be automatically deposited in packages already filled or to be filled, and before the latter are finally closed or sealed.

The principal object of the invention is to provide a simple, economical and efficient machine for automatically depositing articles in packages.

A further object of the invention is to provide a mechanism adapted to enable books or similar articles to be automatically deposited in packages already filled or to be filled, and before the packages are closed or sealed, and without requiring the attendance or supervision of an operator to control or regulate the number of books or articles with respect to the number of packages in which they are to be automatically deposited.

Other and further objects of the invention will appear from an examination of the following description, and from an inspection of the accompanying drawings, which are made a part of this specification.

The invention consists in the features, combinations, parts and details of construction, herein described and claimed.

In the accompanying drawings:—

Figure 1, is a plan view of a machine constructed in accordance with my invention and improvements, showing the same operatively connected with a machine for automatically filling packages in which books or similar articles are to be automatically deposited; only so much of a machine of old and well known form for filling, weighing, closing and sealing packages being shown as is deemed desirable to enable my invention to be understood;

Fig. 2, an enlarged plan view in detail of the clutch mechanism and operating lever mechanism for connecting the feeding mechanism with and disconnecting the same from

the driving shaft by means of which the feeding device is operated;

Fig. 3, an enlarged detail view in side elevation of the clutch mechanism shown in Figs. 1 and 2, with the crank plate or wheel and pitman for operating the feeding plunger indicated in broken lines;

Fig. 4, a view in side elevation of the mechanism shown in Fig. 1, showing the intermittently rotative annulus or turn-table and radial feeding arms of a package filling and weighing machine, the tracks or ways along which the packages are carried, the mechanism for driving the turntable or package carrying mechanism, the clutch-controlling cam mechanism and clutch-operating levers, the hopper or reservoir for containing the books or articles to be deposited in the packages, the feed chute, the reciprocating feeding plunger, and the mechanism for operating the plunger;

Fig. 5, an enlarged detail view in longitudinal vertical section, taken on line 5—5 of Fig. 6, showing the reciprocating feeding plunger, the reservoir or book-containing hopper, and the inclined feed chute in section;

Fig. 6, a front view in elevation showing the book-containing hopper, the feed chute, the package carrying or feeding mechanism with a package in position on the track or ways, and the pulley for operating the package-carrying belt, and

Fig. 7, an enlarged perspective view of one of the books to be operated upon.

In constructing a machine for automatically depositing books or similar articles in packages, in accordance with my invention and improvements, and operatively connecting the same with a package filling, weighing and sealing machine, I provide a package-filling, weighing and sealing machine which may be of any suitable desired, ordinary or well known form, and which comprises a stationary supporting frame having a preferably annular supporting and guiding member 1 provided with flanges 2 and 3 or similar means adapted to form a support for a turntable or annular package feeding member 4 which is rotatively mounted between the bottom supporting flange member 3 and the top flange 2, and provided with a series of radial package-feeding arms 5. These arms project outward radially and down-

ward from the periphery of the ring member 4, and are spaced apart circumferentially with respect to the latter. Their outer extremities are thus adapted to extend downward between parallel curved or segmental guiding strips 6 and 7 arranged on opposite sides of and which may be said to form package-guiding members of a curved track 8 which is mounted upon suitable supporting frame members 9 in position to form a support for packages or receptacles 10 into which books or similar articles 11 are to be deposited. The machine has a main frame 12 which may be of any desired ordinary and well known or suitable form, and comprises upright frame members or standards 13 adapted to form a support for the feeding annulus or ring member 4 and the frame member 1 on which said ring member is rotatively mounted. The track-supporting frame members 9 are, by preference, in the form of radial brackets secured to the main frame 12 by bolts 14 or similar suitable securing means, and to which brackets the track members 6, 7, and 8 are secured in a suitable manner by means of bolts 15 or other suitable securing means. The track members 6, 7, and 8 are arranged in the form of an arc of a circle, the center of which corresponds with the axial center of the ring member 4, said track members being parallel, as already suggested, and concentric with respect to the ring member 4, but, by preference, on a plane below the level of the horizontal plane in which the ring member is located and rotates. A carrier belt 16 is mounted in position to receive the packages 10 as they pass from the discharge end of the circular track. This carrier belt or member 16 is operated by means of a belt-supporting wheel 17 fixed to a shaft 18 which is rotatively mounted in suitable bearings in frame members 19 and 20, and provided with a driving wheel 21, which may be in the form of a belt pulley adapted to be connected with a suitable source of power by means of a belt 22.

The package-feeding annulus or ring member 4 is driven or rotated intermittently by suitable driving means which may be of any desired ordinary or well known form, and which is familiar to those skilled in the art to which this invention relates, and it is therefore deemed unnecessary and undesirable that the same should be described or illustrated herein further than to say that the ring member 4 is provided with a gear ring or gear-toothed portion or member 23, and a driving shaft 24 is rotatively mounted in suitable bearings in a supporting frame member 25, and provided with a toothed pinion or gear wheel 26 fixed to said shaft and in toothed engagement with the toothed gear wheel 23, said shaft 24 being connected with a suitable source of power by means of a main

driving shaft 27 rotatively mounted in suitable bearings in a supporting frame 28, and having a driving wheel or pulley 29 on said main driving shaft and adapted to be connected with a suitable source of power. The shafts 24 and 27 are operatively connected or adapted to be connected and disconnected by means of suitable connecting gear and clutch mechanism which may be of any desired suitable, ordinary and well known form, and is therefore not shown or described herein, such description not being necessary in order to enable this invention to be understood.

A horizontal plunger-supporting member 30 is mounted above the level of the carrier belt 16 upon suitable frame members 31 and 32, the frame member 31 being, by preference, secured to the main frame portion 1 of the machine by means of bolts 33 or similar securing means, and the member 32 being in the form of a supporting leg or standard. A feed chute 34 extends downward at an incline over the track 8 and is provided at its lower extremity with oblique guiding strips 35 which extend inward from opposite sides of the chute and obliquely toward each other in a direction opposite to the direction of movement of the packages or receptacles upon the track, so as to engage the top side flaps 36' of the receptacles 10 and hold them apart or upright while the receptacles are passing successively beneath the discharge end of the chute and in position to receive books or similar articles to be deposited therein. The inner or adjacent ends of the guiding strips or fingers 35 may be joined together or formed in one integral piece so as to form a triangular guiding member adapted to permit the books to pass through from the chute while the side flaps of the package are held apart as already suggested.

A hopper or supply receptacle 36 having upright side walls 37 and front and rear transverse walls 38 forming a rectangular supply chamber or compartment 39 is mounted upon or directly over the plunger-supporting member 31 and the upper extremity of the chute 34, and in position to contain the books or articles 11 to be deposited in the receptacles 10, and in position to permit the books to be discharged from the compartment 39 onto the chute or in such a manner as to pass into the receptacles or packages as the latter are fed or moved into position at the discharge end of the chute by the intermittently rotating feeding arms 5 on the ring member or annulus 4 already described. The hopper 36 or supply compartment has a discharge opening at the bottom extremity thereof, which discharge opening is provided with an adjustable door or shutter 41 for controlling the effective area of the opening. The shutter or door is adapted to be raised or lowered

to different adjusted positions as required in order to permit one or the exact desired number of books or articles to pass through said opening. The shutter is secured in position by means of bolts 42 and nuts 43 in threaded engagement with the bolts. The bolts are anchored in the shutter member and extend through vertical elongated slots 44 in flanges 45 which are adapted to permit the bolts to be moved to different adjusted positions in said slots, as desired. It is obvious that the elongated slots may be in either the flanges 45 or in the shutter member, as desired, though I prefer the arrangement shown in the drawings. A flat reciprocating plunger 46 is slidably mounted between suitable guiding members 47 in position to extend into the bottom portion of the hopper or supply compartment above described. Flanges 48 extend over and in guiding engagement with the opposite side edges or margins of the plunger in such position that the plunger is operatively supported between said flanges and the plunger-supporting member 30 already described. The flanges are secured in position by means of bolts 49, or other suitable securing means. The plunger extends into the compartment 39 through an opening 50, and is provided with an upper transverse shoulder 51 which is adapted to engage and abut against the adjacent end of the lowermost book in the compartment 39 or hopper, so as to force such book out through the discharge opening 40 when the plunger is moved from retracted position, in which it is shown in full lines in Figs. 1, 4, and 5, to extended position, in which it is shown in broken lines in Fig. 5.

The plunger has a relatively thin forward end portion 52, the upper face of which is below the level of the top of the transverse shoulder 51, and flat, and extends from said shoulder to the forward extremity of the plunger. This relatively thin forward portion of the plunger is of sufficient length to extend approximately through the supply compartment of the hopper when the plunger is in retracted position, and to extend out forward on the outside of the hopper a sufficient distance to support a book 11 thereon when the plunger is at its forward limit of movement or in its most forward extended position. (See Fig. 5.) When the plunger is in its retracted position, as shown in full lines in Fig. 5, the relatively thin forward portion 52 extends beneath and in supporting engagement with the lowermost book in the compartment or hopper, and moves forward or outward in supporting engagement with the book which happens to be at the bottom of the pile when the plunger is thrust forward, and then back into supporting engagement with the next book to be operated upon or deposited in the desired receptacle.

A pitman 53 is operatively connected at its forward end, with the rear extremity of the plunger 46 by means of a transverse pin 54 which extends transversely with respect to the plunger and through a head or boss 55 fixed to the plunger, and through front forked arm portions 56 and 57 of the pitman, which is thus pivotally connected with the plunger.

The pitman is operatively connected with a plunger-driving shaft 58 which is rotatively mounted in a suitable bearing 59 on the plunger-supporting frame or frame member 30, and adapted to be connected with a suitable source of power, such, for instance, as a line shaft or shaft and pulley mechanism,—not shown—by means of a belt pulley 60 fixed to the shaft 58, and having a belt 61 on said pulley and adapted to be operatively connected with the line shaft or source of power.

A crank member which is by preference in the form of a crank disk or wheel 62 is mounted upon and rotative with respect to the driving shaft 58, and held in operative position on the shaft by means of a collar 63 secured to the outer end of the shaft and in engagement with the outer side of the wheel, or by similar suitable securing means. A crank pin 64 on the crank disk, extends through a suitable aperture in the rear or adjacent end of the pitman, and a nut or collar 65 serves to hold the pitman in operative engagement with the crank pin or wrist pin. A clutch member, which is by preference in the form of a toothed ratchet wheel 66 is mounted upon and in fixed relation to the rotative shaft 58 and adjacent to the crank disk 62, and a pawl or second clutch member 67 is pivotally mounted upon the crank disk 62 in position to be moved into and out of engagement with the toothed ratchet member 66. This pawl is pivotally secured to the disk member by means of a pivot pin 68 which is anchored in the crank disk member and extends through a suitable aperture in the pawl. One end portion 69 of the pawl is adapted to engage the teeth 70 of the toothed ratchet wheel; and a spring 70 is mounted upon a suitable support 71 on the disk 62 and held at a tension in yielding engagement with the last mentioned end portion of the pawl, so as to constantly tend to press the pawl toward or into engagement with the toothed ratchet member. The pawl is provided with a relatively long curved lever arm portion 71 which may be said to partly encircle the ratchet wheel; and one or more tripping members 72, 73, are supported in position to be moved into and out of the path of movement of the pawl which rotates with the crank disk when the pawl is in engagement with the ratchet member 66, and remains stationary with the crank disk, when

the pawl is out of engagement with the ratchet wheel 66. The tripping finger 72 is, by preference, mounted upon and in fixed relation to a shaft 74 which is rockingly mounted in a suitable bearing 75 on the stationary frame of the machine; and the similar tripping finger 73 is similarly mounted upon and in fixed relation to a rock shaft 76 which is rockingly mounted in a suitable bearing 77 in the stationary frame. These two tripping fingers 72 and 73 are on opposite sides of the axial center of the shaft 58 and ratchet wheel 66, and each in position to engage the curved lever arm portion 71 of the pawl 67 when the pawl reaches a point in its rotation approximately directly opposite a point at which it comes into engagement with the other of said tripping fingers. In other words, the tripping fingers, when two or more are employed, are spaced apart circumferentially with respect to the shaft 58 and ratchet member 66, so as to trip the pawl and cause it to be held out of engagement with the ratchet whenever the pitman 53 and the movement of the plunger 46 are required to be interrupted or stopped and the pawl is in position to be engaged by the adjacent tripping finger. It will be readily apparent that with the two tripping fingers so connected with each other or with suitable operating mechanism as to operate in unison, as shown in the drawings, (see Figs. 1, 2, and 3) one of the tripping fingers will throw the pawl out of engagement with the ratchet wheel 66 when the pitman 53 and plunger 46 are in retracted position, as shown in full lines in Fig. 5 and in broken lines in Fig. 3; and the other tripping finger (73) will throw the pawl out of engagement with the ratchet wheel when the pitman and plunger are in extended position or at their forward limit of movement, as shown in broken lines in Fig. 5, provided the tripping fingers are not held out of the path of movement of the pawl. When the tripping fingers are held out of the path of movement of the pawl, it is obvious that the pawl will be pressed into engagement with the ratchet wheel 66 by the action of the spring 70, as already indicated, and the crank disk will thus be operatively connected with the shaft and will rotate with the same until disconnected by the return of a tripping finger into the path of movement of and into engagement with the pawl. The tripping fingers are operatively connected with each other and with the mechanism for automatically operating the same, and with the intermittently rotative feeding mechanism including the ring member 4 and package feeding arms or fingers 5 already provided, as follows: The rock shaft 74 is provided with an operating lever 78 fixed thereto; and the rock shaft 76, which operates the trip member 73 is

provided with an operating lever 79 fixed thereto, said levers being, by preference in the same horizontal plane, and connected by means of a connecting rod or link 80, one end of which is pivotally connected with the outer end portion of the lever 79, and the opposite end of which is pivotally connected with the central portion of the lever 78 by means of pivots 81 and 82 respectively. (See Figs. 1, 2, and 4.) An extension spring 83 has one end connected with a stationary support, such as the frame member 30, by means of a pin 84, or other similar securing means, and its opposite end is connected with the lever 78, by means of a pin 85 or similar means. (See Fig. 2.) A reciprocating main trip-operating lever 86 is pivotally mounted upon a suitable support 87, which may be in the form of a bracket secured to the frame member 1 already described, and is secured in operative position by means of a headed pin 88. This lever has two lever arms 89 and 90. The lever arm 89 is connected with the lever 78 by means of a connecting rod or link 91, the opposite ends of said link being pivotally connected with said lever 78 and lever arm 89 respectively, or by similar connecting means; and a cam or cam wheel 92 is rotatively mounted upon and in fixed relation to a stub shaft 93 which is journaled in a suitable bearing 94 on the main frame of the machine, and provided with a spur gear 95 in fixed relation to the lower extremity of said stub shaft and in toothed engagement with the toothed gear ring 23 on the intermittently rotative feeding ring member 4, already described, said cam 92 being in operative engagement with the arm 90 of the lever 86 already described.

The lever arm 90 is provided with an anti-friction roller 93' rotatively mounted thereon and supported by an axle 94', said roller being in engagement with the cam face 95 of the cam member 92. This cam is provided with a peripheral or projecting shoulder or trip portion 96 which by preference projects outward beyond the curved peripheral portion 97 of the cam and serves to operate the lever 86, and thereby the tripping members 72 and 73, so as to move the said tripping members from the position in which they are shown in Fig. 1 to the position in which they are shown in Fig. 2, each time said shoulder comes into contact with the roller on the lever arm 90 of the lever 88. It is obvious that the spring 83 constantly tends to move the levers 78, 79, and 86 and thereby the tripping finger 72 and 73 in a direction opposite to that in which they are moved by the action of the cam shoulder 96, and that said spring serves to yieldingly hold said members in the position in which they are shown in Fig. 1, when the projecting shoulder or trip 96 on the cam is not in engagement with

the roller 93' or lever arm 90. The spring 83 thus serves to hold the tripping fingers 72 and 73 within the path of movement of the pawl 67, so as to cause the pawl to be engaged and held out of engagement with the toothed ratchet wheel or clutch member 66 whenever the cam 92 is not in a position to cause said tripping fingers to be moved out of the path of movement of the pawl. It follows as a matter of course, that the cam, which operates intermittently, and is so operated synchronously with and by means of the package feeding annulus or ring member 4 and toothed gear member 23, automatically operates the clutch mechanism including the tripping fingers 72 and 73, so as to permit the pawl to engage the toothed ratchet member 66 of the clutch mechanism, thereby causing the crank disk and plunger to be operated by the constantly rotating shaft 58 until the spring 83 causes the tripping fingers 72 and 73 to be moved into position to engage the pawl and release the connection between the shaft 58 and the crank disk and plunger and pitman mechanism, and permit the crank disk and plunger mechanism to stop while the shaft 58 is permitted to continue in rotation.

In Figs. 1, 3 and 4, the tripping and clutch mechanism is shown in the position which it would occupy at the moment of the completion of an operation of depositing a book or article in a package, or immediately following the completion of such operation, and with the intermittently rotative package-feeding mechanism stationary or in the position which it would occupy when just completing the operation of moving a package into position to receive a book from the book-discharging plunger, or just beginning or in the act of performing the operation of moving one package from position at the end of the discharge chute 34 and another into position beneath the chute. This last mentioned operation would cause the cam 92 with its tripping shoulder or trip-operating member 96 to make a complete revolution so as to cause said tripping member 96 to come into contact with and to operate the main tripping lever 86, and thereby operate the tripping fingers 72 and 73, so as to cause the latter to move from the pawl-engaging or pawl-tripping position in which they are shown in Figs. 1 and 3, to the pawl-releasing position in which they are shown in Fig. 2. Releasing the pawl causes the crank, pitman and discharging-plunger mechanism to be operatively connected with and to be operated by the constantly rotating driving shaft 58, by permitting the pawl 67 thus released by a tripping finger to engage the ratchet member 66 of the clutch mechanism, whereby the discharging plunger would be operated from one extremity of its path of movement to the other extremity of its movement,—for in-

stance, from the position in which it is shown in full lines in Figs. 4 and 5, to the position in which it is shown in broken lines in Fig. 5.

From the foregoing it is obvious that, with the parts in the position in which they are shown in Figs. 1 and 3, the pawl 67, upon being released by the operation of the tripping finger 72, will rotate with the crank disk or crank member 62 until said crank member has made approximately one-half of a complete revolution thereby bringing the curved lever arm portion 71 of the pawl into such position that it is engaged by the tripping finger 73 which is held in the path of movement of said pawl by the action of the spring 83 already described. Such engagement of the pawl by the tripping finger 73 will obviously cause the pawl to be thrown out of engagement with the ratchet wheel member 66 of the clutch mechanism, thereby causing the crank and pitman mechanism to become disconnected from operative engagement with the rotative shaft 58. The crank and pitman mechanism and discharging plunger are thus stopped with the plunger in the position in which it is shown in broken lines in Fig. 5, or in extended position. The next operation of the cam with its tripping member 96 will cause the tripping fingers 72 and 73 to again move from the position in which they are shown in Fig. 1 to the position in which they are shown in Fig. 2, thereby causing the tripping finger 73 to move out of the path of movement of and out of engagement with the pawl 67, and permitting the pawl to engage the ratchet member 66 and rotate therewith to the position shown in Fig. 3. The plunger will then again be in the position in which it is shown in full lines in Fig. 5. It is not deemed necessary or desirable to show the pawl 67 in contact with the tripping finger 73, for the reason that upon being released by the tripping finger 72 when in the position shown in Fig. 3 it would rotate with the crank disk in the manner above indicated, until the pawl would come into contact with the tripping finger 73 held in the path of movement of said pawl by the spring 83, as already suggested. It should be noted, however, that with two tripping fingers employed, the operation will be as above described, and that the plunger will be stopped in the position shown in full lines in Figs. 1, 4, and 5, and in a second position with plunger and pitman, as indicated in broken lines in Fig. 5, and with the next adjacent package or receptacle in position beneath the discharge chute 34, but that the last mentioned package will not receive a book or article from the plunger or from the supply receptacle. In other words books will be deposited in each alternate package or receptacle 10 only, when two tripping fingers 72, 73 are employed. In case it is found

desirable that a book should be deposited in each and every package or receptacle 10, or one book for each intermittent movement of the package feeding mechanism or ring member 4 with its feeding arms 5—there being a package for each arm 5—it is only necessary to omit the tripping finger 73, or said tripping finger with the mechanism including lever 79 and connecting link 80 for operating said tripping finger, or to disconnect said finger or its said operating mechanism from the lever 78, thus leaving but a single tripping finger 72 for engaging the pawl 67. With only a single tripping finger employed—for instance, the tripping finger 72—or with the tripping finger 73 disconnected, which may be readily accomplished by the removal of pivot or connecting pin 82, it is plain that upon releasing the tripping finger 72 from engagement with the pawl 67, with the parts in the position shown in Figs. 1, 3 and 4, with particular reference to Fig. 3 the pawl and crank member will make a complete revolution, instead of one-half of a revolution each time the pawl is released from engagement with the tripping finger thus remaining, and a book will be discharged and deposited in a package once for each operation of the cam and of its tripping member 96 and the package-feeding mechanism which operates said tripping mechanism and feeds the packages into position to receive the books or articles so to be deposited therein. With either one or both of the tripping fingers 72, 73, employed and adapted to operate as above described, it is obvious that the cam 92 with its tripping member 96 is operated so as to operate the clutch mechanism and operatively connect the crank, pitman, and discharging plunger mechanism with the constantly rotating shaft 58 once for each operation or step by step movement of the intermittently rotating package-feeding mechanism or ring 4 and feeding arms 5. The operations of the plunger 52 and its pitman and crank mechanism take place almost entirely while the said intermittently rotating feeding mechanism is stationary, or during the intervals between the intermittent step by step movements of the package-feeding mechanism, and while the packages are stationary. The books are dropped from the projecting front portion of the plunger during the return movement of the plunger from the position in which it is shown in broken lines in Fig. 5 to the position in which it is shown in full lines in said figure, thus insuring the dropping of each book in the proper position upon the chute or into the required package, regardless of variations in speed in the rapid operation of the device. The books are thus supported during their outward movement from the hopper or supply receptacle upon a portion of the plunger which extends beneath and

moves outward with the book located at the bottom of the supply contained in the hopper, and are deposited in the required packages or receptacles successively while the latter and the package feeding mechanism 70 are stationary, so as to permit the filling, and weighing of the packages, and without requiring the attendance or services of an operator or attendant to deposit the books in the required packages. 75

The tripping member 96 on the cam 92 may be mounted upon the cam in any suitable manner, and may be of any desired suitable form adapted to operate the main tripping lever 86 or similar tripping mechanism. The cam member 92 may be of the ordinary form of cam well known and in common use on machines of the type shown, and the tripping member 96 need not be in one integral piece with such cam but may be in the form of a roller mounted on the cam member if desired. 85

I claim:—

1. In a machine of the class described, the combination of a supply receptacle provided with a discharge opening, a reciprocating plunger having a feeding portion movable toward and from said discharge opening and adapted to engage an article to be fed from said supply receptacle, crank and pitman mechanism operatively connected with said plunger, a rotative shaft adapted to be connected with a source of power, for operating the crank and pitman mechanism, clutch mechanism, for connecting the crank mechanism with said shaft and disconnecting it therefrom, a toothed gear member, intermittently rotative tripping mechanism comprising a toothed gear wheel in toothed engagement with said first mentioned toothed gear member, and reciprocating tripping mechanism adapted to operatively engage said clutch mechanism and operatively connected with and adapted to be operated by said intermittently rotative tripping mechanism. 100

2. In a machine of the class described, the combination of a supply receptacle provided with a discharge opening, a reciprocating plunger having a feeding shoulder portion adapted to extend into said receptacle and movable toward and from said discharge opening, said plunger having a forward portion projecting forward beyond said shoulder and adapted to extend through said discharge opening and in supporting engagement with an article to be operated upon by said plunger, plunger-operating mechanism connected with and adapted to move the plunger from retracted to extended position and from extended to retracted position, and means for stopping the plunger in retracted position and in extended position alternately. 115 120 125

3. In a machine of the class described, the 130

combination of a supply receptacle provided with a discharge opening, a reciprocating plunger adapted to engage an article to be discharged from the interior of said receptacle, crank and pitman mechanism operatively connected with said plunger, a rotative shaft adapted to be connected with a source of power, a clutch member upon and adapted to rotate with said shaft, a second clutch member upon the crank member, spring mechanism in operative engagement with one of said clutch members and adapted to hold the same normally in engagement with the other of said clutch members, a tripping member movable into and out of the path of movement of the spring-engaged clutch member and adapted to engage and cause the movement of the latter out of engagement with the first mentioned clutch member, to release the clutch, means for holding said tripping member normally in position to engage the spring-engaged clutch member, and means for automatically moving said tripping member out of engagement with the last mentioned clutch member.

4. In a machine of the class described, the combination of a supply receptacle provided with a discharge opening, a plunger movably mounted and adapted to engage an article to be discharged from the interior of said receptacle, crank and pitman mechanism operatively connected with said plunger, a rotative shaft adapted to be connected with a source of power, a clutch member upon and adapted to rotate with said shaft, a second clutch member upon the crank member of said crank and pitman mechanism, spring mechanism in operative engagement with one of said clutch members and adapted to hold the same normally in engagement with the other of said clutch members, a plurality of tripping members each movable into and out of engagement with said spring-engaged clutch member, for releasing the clutch, and means for operating said tripping members.

5. In a machine of the class described, the combination of a supply receptacle provided with a discharge opening, a reciprocating plunger adapted to engage articles to be successively discharged from the interior of said receptacle, crank and pitman mechanism operatively connected with said plunger, a rotative shaft adapted to be connected with a source of power, a ratchet member fixed to said shaft, a spring-pressed pawl mounted upon the crank member of said crank and pitman mechanism and adapted to be held yieldingly in engagement with said ratchet member, for connecting the crank and shaft mechanism, a tripping member mounted on a suitable support and movable

into and out of tripping engagement with said pawl, resilient means operatively connected with said tripping mechanism for yieldingly holding said pawl-engaging tripping member in engagement with said pawl, and means for automatically moving said pawl-engaging tripping member out of engagement with the pawl.

6. In a machine of the class described, the combination of a supply receptacle provided with a discharge opening, a reciprocating plunger adapted to successively engage articles to be discharged from the interior of said receptacle, said plunger having a forward portion adapted to extend through said discharge opening and in supporting engagement with an article on the outside of the receptacle, a rotative shaft adapted to be connected with a source of power, a clutch member fixed to said shaft, crank and pitman mechanism operatively connected with said plunger, a spring-pressed pawl mounted upon the crank member of said crank and pitman mechanism and adapted to be moved into and out of engagement with said first mentioned clutch member, a plurality of tripping members movable into and out of the path of movement of and adapted to alternately engage said pawl, for releasing the clutch mechanism when the plunger is at the forward and rearward extremities of its path of movement, respectively, and means for automatically operating said tripping members.

7. In a machine of the class described, the combination of a supply receptacle provided with a discharge opening, a reciprocating plunger having a feeding shoulder portion adapted to extend into said receptacle and into engagement with an article to be discharged from the interior of the receptacle, said plunger having a forward portion projecting forward beyond such shoulder and adapted to extend through the discharge opening and in supporting engagement with such article on the outside of the receptacle when the plunger is in extended position, crank and pitman mechanism connected with said plunger, a rotative shaft adapted to be connected with a source of power, for operating the crank and pitman mechanism, clutch mechanism for connecting the crank mechanism with said shaft and disconnecting it therefrom, and means for operating the clutch mechanism.

Signed at Chicago, Illinois, June 3, 1916.

JOSEPH PROCK.

Witnesses:

HARRY IRWIN CROMER,
W. HARDING.