



(11) **EP 1 585 360 B1**

(12) **EUROPEAN PATENT SPECIFICATION**

(45) Date of publication and mention of the grant of the patent:
10.05.2017 Bulletin 2017/19

(51) Int Cl.:
H04R 1/04 (2006.01) H04R 3/00 (2006.01)

(21) Application number: **04450075.9**

(22) Date of filing: **30.03.2004**

(54) **Power supply of phantom power supplied microphones**

Stromversorgung von phantomgespeisten Mikrofonen

Dispositif d'alimentation de microphones à alimentation fantôme

(84) Designated Contracting States:
AT BE BG CH CY CZ DE DK EE ES FI FR GB GR HU IE IT LI LU MC NL PL PT RO SE SI SK TR

(43) Date of publication of application:
12.10.2005 Bulletin 2005/41

(73) Proprietor: **AKG Acoustics GmbH**
1230 Wien (AT)

(72) Inventor: **Nell, Kurt Dipl.-Ing.**
2384 Breitenfurt (AT)

(74) Representative: **Patentanwälte**
Barger, Piso & Partner
Operngasse 4
P.O. Box 96
1010 Wien (AT)

(56) References cited:
DE-A- 3 933 870 US-A- 4 541 112

EP 1 585 360 B1

Note: Within nine months of the publication of the mention of the grant of the European patent in the European Patent Bulletin, any person may give notice to the European Patent Office of opposition to that patent, in accordance with the Implementing Regulations. Notice of opposition shall not be deemed to have been filed until the opposition fee has been paid. (Art. 99(1) European Patent Convention).

Description

[0001] The present invention relates to the power supply of microphones.

[0002] The power supply of microphones is conventionally provided by a power supply source, for example, using a mixer. During phantom power supply, the positive pole of the feed voltage is applied through two identical feeder resistances through two cable conductors of the audio cable. The return of the current occurs through a third conductor connected to pin 1 of an XLR plug. To be able to efficiently use the voltage supplied by the phantom power supply for the power supply of capacitor microphones, the current consumption of the microphone should be as small as possible to prevent an excessively large voltage drop at the feeder resistances. The maximum current consumption with 48-V capacitor microphones is 10 mA. The phantom power supply is here standardized according to DIN EN 61938 (formerly IEC 268).

[0003] To generate the polarization voltage on the microphone membrane, whose value is usually in the range of 20-100 volts dc, one uses primarily combinatorial circuit parts or voltage converters. The remaining microphone electronics are usually supplied with power by a linear regulation, which maintains either the supply feed voltage or the supply current at a predetermined value. For microphones with little power consumption, this type of power supply is appropriate. The linear regulation becomes problematic when the power consumption in the microphone increases, for example, by the use of processors, A/D converters, LED displays, etc. In this case, a large portion of the energy that is made available by the phantom power supply is destroyed in the linear regulation elements. However, since, according to the standard, the phantom power supply is limited in its current by the feeder resistances, the maximum supply voltage for the audio amplifier immediately decreases due to the linear regulation in the microphone, which results in a reduction of the maximal audio output voltage of the microphone.

[0004] An additional problem consists of the generation of the polarization voltage. This voltage is usually applied through a high-ohm resistance to the microphone membrane. Here, the required power is very low. Voltage regulators with high efficiency for the generation of this practically powerless polarization voltage are also difficult to construct.

[0005] An additional problem concerns the remote control of microphones. With microphones, there is an increasing need to be able to regulate or to change important microphone parameters via remote control. These parameters include the polarization voltage on the membrane and the associated sensitivity of the capacitor microphone, the directional characteristic of the microphone, the type of the phantom power supply (12 V, 24 V or 48 V), a series number, calibration data from the manufacturer, as well as a weakening of the signal and

a connectable filter for the audio signal.

[0006] DE 3 933 870 A1 discloses a method for the remote control of microphone parameters, such as directional characteristic, step sound filter, or preliminary damping. In the process, the supply voltage transferred to the cable conductor is regulated via a remote control unit, for example, in the mixing table, in such a manner that its amount represents control information for the microphone. On the side of the microphone, the supply voltage is uncoupled and applied to an evaluation circuit, which generates a control signal as a function of the amount of the supply voltage. By this method of data transfer, only a small quantity of control information can be transmitted to the microphone, and therefore also only a few parameters can be remote-controlled in the microphone:

[0007] An additional, so far not optimally solved, problem concerns the polarization voltage generation on the membrane of a capacitor microphone. The level of the polarization voltage is incorporated directly in the level of sensitivity of the microphone capsule. As a result, it is also possible to regulate the sensitivity of capacitor capsules with the aid of the polarization voltage. This is of particular advantage in connection with the use of double membrane capsules, because these capsules not only allow the regulation of the sensitivity but also of the directional characteristic, in the case of a separate supply of the individual membranes with polarization voltage.

[0008] It is known how to regulate the polarization voltage with the aid of fixed resistances or trim resistances. In the process, during the assembly of the microphone, a one-time adjustment of the polarization voltage occurs. The directional characteristic is here predetermined once with fixed resistance ratios. Using this method, the compensation of tolerances in the sensitivity that are caused by the assembly of the microphone capsules as well as by aging processes is only possible with difficulty. For this purpose, one would need a compensation of the polarization voltage during an acoustic measurement of the sensitivity in the assembled state of the microphone. It is also not possible to compensate for sensitivity tolerances in the case of different directional characteristics.

[0009] In connection with the power supply of microphones, there is a need for a solution wherein the power made available by the phantom power supply is optimally used and converted into the operational voltages required for the individual output receives, such as audio amplifier, microphone capsule, processors, controller, A/D converter, LED displays, etc. Here, the goal is to be able to use as large as possible a proportion of the power made available by the phantom power supply for supplying the audio amplifier.

[0010] According to the invention, these goals are achieved with a microphone comprising a power supply circuit for the individual power receivers, which microphone is characterized in that the power supply circuit comprises a control unit that converts the direct current transmitted via the cable conductors of the audio cable

into an alternating current, a transformer connected to the control unit, and supply loops for the individual power receivers, where supply loops are inductively coupled by means of separate windings on the transformer to the alternating current generated by the control unit and to each other.

[0011] In the process, all the voltages required for the above-mentioned power receivers are generated by a power supply circuit, for example, a DC/DC converter, which has the following properties. The power supply circuit is regulated or operated in such a manner that there is a power adaptation to the phantom power unit. Therefore, the maximum possible power that the phantom power unit makes available can always be consumed by the power supply circuit of the microphone. The primary current consumption of the power supply circuit is constant. The power supply circuit therefore behaves, with the respect to the phantom power unit, as a constant-current sink. The individual supply loops for the individual power receivers are uncoupled in the power supply circuit by means of a transformer, to satisfy the different requirements of the individual power receivers: high voltages and small currents for polarization voltage, moderate voltage, and moderate current consumption for the audio amplifier, as well as small voltages and large currents for the digital electronics, with as little power loss as possible.

[0012] The advantageous effect of a capacitor microphone according to the invention is obvious: using the presented power supply concept, the electrical power made available by the phantom power unit is optimally used. As a result, microphones can be fitted with new functions (for example, remote control, new operating concept, automatic compensation possibilities, etc.) while the maximal audio output voltage of the microphone remains the same. The generation of the essentially power-free polarization voltage occurs practically as a secondary product by a simple additional winding on the transformer.

[0013] An additional advantage is that as a result of the use of as high an ohm level as possible, with a constant power source at the input of the power supply circuit, the switch ripple of the power supply circuit or of the DC/DC converter can very easily be filtered out. The usage of such a constant power source at the input of the power supply circuit is not known in the prior art. Neither from the already cited document DE3933870A1 nor from other systems where transformers are applied in the same manner as in the present system, such as in US4,541,112. With the increasing adaptation possibilities in the microphone, such as changing the polarization voltage and thus the sensitivity, continual changing of the directional characteristic of double membrane capsules and changing the control signals for microprocessors for storing calibration data, as well as modifications of the frequency range, the maximal audio output voltage, the amplification, or THD of the audio amplifier, there is a need for a substantially higher rate of data transfer to via a remote control to the microphone.

[0014] According to the invention, these goals are achieved by a method for the remote control of a microphone, characterized in that a frequency-modulated voltage is applied as a control signal to at least one of the two cable conductors through which the phantom power supply also occurs, and in that the frequency-modulated voltage, on the microphone side, is applied to a control electronics, for example a microcontroller or a CPLD (Complex Programmable Logic Device), which sends commands to individual power receivers according to the frequency-modulated control signals.

[0015] In this method, a frequency-modulated voltage is overlaid on the supply voltage of the phantom power supply. A data transfer occurs from a transmitter, which is arranged, for example, in the mixing table or in a device before the mixing table, via the audio lines to the microphone. The carrier frequency for the FSK modulation here is higher than the audio frequency range to be transmitted by the microphone.

[0016] By using frequency-modulated signal transmission, in contrast to transmission with direct current, a substantially higher data transfer rate can be achieved. As a result, using a certain protocol, a large number of parameters can be transmitted. The carrier frequencies for the modulation are preferably approximately 100 kHz, and they can be separated from the audio signal using filters.

[0017] To satisfy the need for low tolerances in the polarization voltage of capacitor microphones - for example, in view of the sensitivity, a tolerance of ± 0.5 dB is sought - a solution is needed which allows a flexible adjustment of the polarization voltage even in the assembled state of the microphone.

[0018] According to the invention, this is achieved by a capacitor microphone, characterized in that the capacitor microphone comprises at least one circuit for regulating the polarization voltage, where the circuit for the regulation of the polarization voltage comprises an analog regulation loop supplied with an unregulated voltage, and a digital regulation loop, in that the digital regulation loop comprises a control electronics, for example a microcontroller or a CPLD, that provides, to the analog regulation loop, a desired value for the polarization voltage, which is calculated using correction factors, and in that, for the purpose of feedback, the output of the analog regulation loop is connected with a control electronics.

[0019] In this process, the polarization voltage is adjusted by a voltage regulation loop that is integrated in the microphone. The desired value of the polarization voltage is preestablished in this circuit via a D/A converter by a control electronics. As a result, a finely graded adjustment of the polarization voltage can be carried out. The desired value of the polarization voltage can also be transmitted by remote control to the control electronics. The tolerance of the obtained polarization voltage now depends on the tolerance and the thermal behavior of a reference voltage source.

[0020] The regulation of the polarization voltage via a

digitally controlled regulation loop in the microphone allows a very precise, interference-resistant, and remote-controllable adjustment of the polarization voltage of capacitor microphones. As a result, it becomes possible, during the manufacture and in the measurement-technological verification of capacitor microphones, to achieve very narrow tolerance requirements with respect to the sensitivity and directional characteristic. The remote-controllable adjustment of the polarization voltage has the advantage that readjustments by fixed resistances or trim resistances are no longer necessary; this fact has a positive effect with respect to cost. In comparison to the existing solutions with fixed set polarization voltages, the following additional possibilities arise in connection with the capacitor microphone according to the invention:

[0021] As a function of the individual properties of double membrane capsules, in the case of differently regulated directional characteristics, the different microphone sensitivities can be compensated for and the required correction factors needed to compensate the polarization voltage can be stored.

[0022] In combination with a remote control, as described above, for example, the polarization voltage can be calibrated during an acoustical measurement with closed microphone, and correction factors can again be stored.

[0023] It is of particular advantage to have the possibility to vary the polarization voltage of a remote-controlled microphone and thus its directional effect during the operation. For example, the microphone can acoustically follow moving actors, for example, in the performance of an opera.

[0024] A capacitor microphone according to the invention allows an aging-caused recalibration of the microphone sensitivity, without having to disassemble the microphone, which again means a cost saving for the customer. During the replacement of the microphone capsule, the original sensitivity of the microphone can thus be readjusted later, that is, after the incorporation, by remote control.

[0025] Below, the invention is further explained with reference to drawings. In the drawings:

Fig. 1 shows a block diagram of a capacitor microphone according to the invention, with a power supply circuit,

Fig. 2 shows a block diagram of an embodiment of a capacitor microphone according to the invention, with a power supply circuit,

Fig. 3 shows a circuit diagram of a transistor-LED constant-power source according to the state of the art,

Fig. 4 shows a circuit diagram of a constant-power source with counter-coupled transistors according to the state of the art,

Fig. 5 shows a block diagram of a capacitor microphone, which is connected to a remote control unit,

Fig. 6 shows a block diagram of a capacitor microphone with integrated circuit for adjusting the polarization voltage, and

Fig. 7 shows the circuit for adjusting the polarization voltage, comprising an analog and a digital regulation loop.

[0026] Fig. 1 is a block diagram that shows the principal components of a microphone according to the invention.

The phantom power supply of the microphone, shown in Fig. 5, is carried out by a phantom supply unit 31 through feeder resistances 32, 33 of identical magnitude, which are arranged behind the 3-pole plug 4, for example, an XLR plug, in or before the mixing table. Such a phantom power supply is shown in Fig. 5. According to the standard, three phantom power supplies are possible: the associated values of the feeder resistances for a 12-V, 24-V, or 48-V supply are 680 Ω , 1.2 k Ω , or 6.8 k Ω , respectively. The lines 1 and 2 here represent cable conductors supplied by the phantom supply unit; line 3 represents the ground line that is usually connected to the grounded cable shielding. Through the audio cable, that is, through lines 1, 2 and the resistances 5 and 6, the phantom power unit 31 is connected to the input of the power supply circuit 11 according to the invention. A capacitance 7 smoothes the supply voltage against the grounding. The resistances 5 and 6 are the feeder resistances in the microphone. They are used for decoupling the power supply of the microphone from the output of the audio amplifier 10. The feeder resistances of the microphones 5 and 6 are assigned as additional internal resistances of the phantom power supply 31. Power adaptation exists when the internal resistance of the phantom power unit is identical to the internal resistance of the power supply circuit 11 in the microphone. Thus, in the case of power adjustment, half the voltage of the phantom power supply is the supply voltage for the power supply circuit 11. This power, which is the maximum that can be produced by the phantom power unit 31, is now distributed through the power supply circuit 11 in the form of a DC/DC converter to all energy-consuming parts in the microphone. The excess power is here made available to the audio amplifier 10 to achieve as high as possible the maximum audio output voltage of the microphone. With regard to different power supply voltages (according to standard 12 V, 24 V, or 48 V), the circuit can be designed in such a manner that the power adaptation to different phantom power supplies occurs automatically. This task is then taken over by the control unit 12 described below.

[0027] The power supply circuit 11 comprises a power source 13, a control unit 12, and a transformer 14 connected to the control unit 12. The control unit 12 with the transformer 14 forms a circuit unit, where the DC voltage is converted into AC voltage. In this case, the transformer is a part of the oscillation generating circuit. Naturally, alternating current can also be generated by the control unit 12 independently of the transformer. The control unit 12 then consists of an oscillating circle that is independ-

ent of the transformer, and which generates alternating current. The transformer only serves the function of converting the alternating current into the individual output voltages.

[0028] In a preferred embodiment, the AC signal has a frequency in the range of 100-130 kHz. The AC signal can also be freely oscillating; this represents the simplest embodiment possibility for such a circuit. The only important factor is that the frequency range of the AC signal must lie outside of the audio frequency range in order to not produce any interferences with the audio signal, which interferences cannot be eliminated by simple filtering. On the other hand, the frequency should also not be too high, because otherwise the degree of efficiency of the circuit decreases and transmission interferences can be expected.

[0029] An additional advantage of using a frequency of 100-130 kHz is that this frequency can also be used as cycle pulse for a control electronics 39 that is provided in the microphone. As a result, the interfering signals generated by digital technology are minimized, because no additional mixed products are produced between the digital cycle time and the oscillation frequency of the DC/DC converter.

[0030] The produced AC signal is applied to a transformer 14. As a result of the individually separated windings on the transformer, separate current loops 15, 16, 17 are produced for supplying the individual energy-consuming parts. This uncoupling allows, with as small as possible a power loss, the simultaneous supply of consumers that require high voltages but low current, as well as consumers with high current consumption and low voltage. The diodes 18, 19, 20 and the capacitors 21, 22, 23 in the individual supply loops 15, 16, 17 represent a rectifier circuit for converting AC voltage into DC voltage. Naturally, more complicated and more efficient rectifier circuits from the state of the art can be provided in the individual supply loops. Supply loop 16 serves to supply the microphone capsule 9 with the polarization voltage, which is applied via a resistance 8 to the microphone capsule 9.

[0031] The invention is of course not restricted to capacitor microphones, since any kind of microphones, in particular dynamic microphones, can be connected to a phantom power supply. The individual power receivers are supplied by the phantom power unit in the same way as shown in Figs. 1 and 2. But in the case of dynamic microphones a polarisation voltage is not necessary, therefore supply loop 16 is not needed.

[0032] The use of a constant-current generator 13 at the input of the DC/DC converter ensures a constant primary current uptake. The constant-current generator 13, with respect to the phantom power unit 31, behaves like a constant-current sink and it represents a constant-current generator for the power supply circuit 11. A constant-current generator 13 having as high an ohm level as possible, among other effects, simplifies the filtering of the switching ripple produced during the DC/AC conversion

and thus it simultaneously prevents the overlaying of interferences on the audio signal. An electrical component of this type is very well known to a person skilled in the art who is familiar with the state of the art. Circuit examples for constant-current generators from the state of the art are shown in Figs. 3 and 4. Fig. 3 shows a "transistor LED" constant-current generator with a bipolar transistor. With this current generator, the LED is operated in the flow direction. As a result, a constant voltage is applied to the LED, with such a voltage also being applied to the series connection of the base emitter diode of the transistor with the emitter resistance. The current delivered by this current generator therefore is $I = (U_{LED} - U_{bc}) / R_e$, where U_{LED} is the voltage drop at the LED, U_{bc} is the base emitter voltage, and R_e is the emitter resistance.

[0033] The circuit in Fig. 4 contains a constant-current generator with two counter coupled degenerated transistors 28, 29 with an additional integrated constant-current generator 30. This circuit is preferred because of better properties in view of a constant-current and a higher starting resistance. The current generator 30, at the preliminary resistance R_c , generates a voltage drop that is equal to the voltage drop U_{Rc} at the emitter resistance R_e of the transistor 28. The current of the constant-current generator here is $I = U_{Rc} / R_e$. The transistor 29 here forms, with transistor 28, a counter coupled degenerate system that ensures identical voltage drops at the resistances R_c and R_e . As a result, the current I of the current generator is also kept constant. The current of the current generator 30 is therefore smaller by a factor of 100 than the constant-current that finally flows into the DC/DC converter 11.

[0034] Naturally, other types of constant-current generators can also be provided, for example, a current generator with an inverted operation amplifier, Howland current generators, etc.

[0035] The supply voltage generated by the power supply circuit 11 for the audio amplifier 10 is not regulated in a preferred embodiment. In the supply loop 16 for the microphone capsule 9, a regulation circuit 47, 48 is provided between diode 18 and resistance 8, comprising of a digital regulation loop 47 and an analog regulation loop 48, provided for the polarization voltage applied to the microphone capsule 9. Fig. 6 in combination with Fig. 7 illustrates such a preferably remote controllable, regulation circuit 47, 48. The control signals required for the regulation of the polarization voltage can be transmitted through at least one of the two cable conductors 1, 2. The detailed structure and the method of operation of such a regulation circuit 47, 48 are described further below. In the remaining supply loops one can also provide regulation circuits, provided current and voltage limits are not already provided in digital circuit parts. In the preferred embodiment of Figs. 1 and 2, no regulation circuit is provided in the supply loop 15 for the audio amplifier 10. As a result, the entire power - which is not used for other circuit parts, such as processors, control electronics 39, polarization voltage at the microphone capsule 9,

A/D or D/A converter 44, 46, LED displays 25 - is available for the audio amplifier 10. As a result, a high maximal audio output voltage can be achieved in a current-saving design of the audio amplifier 10, to achieve a high maximal audio output voltage. In principle, the supply voltage for the audio amplifier 10 as a result can also exceed the voltage made available by the phantom power supply. Because of the method of action of the power supply circuit 11, it is also possible to produce very simple positive and negative supply voltages for the audio amplifier 10. As a result, the audio amplifier 10 can also use grounding as the rest potential. The supply feed voltage of the audio amplifier (10) can therefore be symmetrically with respect to the grounding.

[0036] In a more advantageous embodiment, the DC/DC converter 11 of the above described type works with a degree of efficiency of approximately 82%. Because, even in the most advantageous case, power is lost at DC/DC converters, it is advantageous to series-connect, if possible, the consumers to the DC/DC converter. As a result of the use of a constant-current generator 13, it is easily possible to connect consumers with constant-current consumption, for example, a logic supply 24, to make available a fixed direct current, for example, for a control electronics 39, or LED display 25, A/D or D/A converter 44, 46, etc., in series to the DC/DC converter 11.

[0037] A corresponding embodiment of the power supply circuit 11 is shown in Fig. 2. The difference, compared to Fig. 1, is that only the polarization voltage and the voltage for the audio amplifier 10 are generated through the DC/DC converter. The other consumers, like the logic supply 24 for making available a fixed predetermined direct current, for example, for a control electronics 39, or LED displays 25, are series-connected to the DC/DC converter. The series-connected DC/DC converter 11 for the digital supply acts as an active load resistance, where the energy used at this resistance is not converted into heat but, in a majority proportion, is converted to a usable supply power for the audio amplifier 10 and the polarization voltage on the microphone capsule 9.

[0038] As shown in Fig. 2, in connection with a logic supply 24 for making available a reference voltage or additional digital electronics, a Zener diode 27 is provided, which is particularly well suited for stabilizing the voltage. Through this diode 27, any current that is not consumed, but delivered by the constant-current generator 13, is released to the grounding. In principle, one can use, instead of the Zener diode 27, any other constant-current generator or a shunt regulator.

[0039] The released power is the product of the current of the constant-current generator 13 and the voltage applied to the power supply circuit 11. In the block diagram of Fig. 1, the entire voltage is applied to the DC/DC converter 11 and all the voltages are generated through the DC/DC converter. In the block diagram of Fig. 2, the voltage is divided into a portion that is applied to the DC/DC converter 11 and a second portion that is applied to the

LEDs 25 and the digital supply. The DC/DC converter represents an active preliminary resistance for the LEDs 25 or the digital supply. Since the current consumption of the digital supply is not constant, but the current I is kept constant by the current generator 13, the excess current that exists, depending on the state of operation of the digital electronics, has to be bled off through the Zener diode 27. For the supply of the audio amplifier 10, the power $P = I \times$ voltage available at the DC/DC converter \times degree of efficiency of the DC/DC converter is available. For the LEDs and the digital electronics, the power $P = I \times$ voltage at the digital electronics and LEDs is available. **[0040]** For illustration, an example is given: The current consumption of the audio amplifier 10, in the uncontrolled state, is approximately 0.8 mA, the current consumption of the digital electronics is approximately 4.2 mA. The current generator 13 delivers a constant-current of approximately 4.7 mA. Thus, in this special case, it is more advantageous to lead the voltage for the digital electronics, not through the DC/DC converter, but to use a series connection to the DC/DC converter. Moreover, in additional developments, it may turn out that, with regard to energy, it is more advantageous to lead all the required voltages, as in the solution shown in the block diagram of Fig. 1, through the DC/DC converter.

[0041] The conversion of the supply voltage for the audio amplifier 10 in this case leads to a maximum available power for the amplifier of: $P = 4.7 \text{ mA} \times 18 \text{ V} \times 0.82 = 69 \text{ mW}$. The voltage at the audio amplifier 10 thus is $U = P/I = 69 \text{ mW}/0.8 \text{ mA} = 55 \text{ V}$. This voltage is much higher than the voltage of 24 V delivered by the phantom power supply unit 31 during power adaptation. However, since the polarization voltage is also generated on the membrane of the capsule 9, the value of the supply voltage of the audio amplifier 10, which is actually reached, is slightly lower than this value, but still much higher than the 24 V available without the DC/DC converter.

[0042] Fig. 5 shows a microphone 54, which is connected with a transmitter or a remote control unit 55. The remote control of important microphone parameters here occurs directly through the audio cable, that is, through the lines 1, 2. The control unit 55 is preferably on the mixer, or arranged in front of it. A microcontroller 35 with a parameter control input 34 controls a frequency modulator 36, which feeds a frequency-modulated signal with the same level into the two cable conductors 1, 2 of the audio cable. The frequency-modulated signal can then be suppressed as a common mode signal in the input-difference amplifier 42. At the same time, a supply voltage of a phantom power unit 31 is applied through the feeder resistances 32, 33 to the two cable conductors 1, 2. In a preferred embodiment, the frequency-modulated signal is applied to only one of the conductors of the audio cable, namely, to the conductor 2, which is not intended for the audio signal.

[0043] In a preferred embodiment, the frequency-modulated signal is generated by FSK (frequency shift keying) or CPFSK (continuous phase FSK). Both modula-

tions are procedures that are known from digital data transfer technology. In principle, it is also possible to use ASK (amplitude shifting keying) or PSK (phase shift keying) modulation. However, ASK is much more likely to be subject to interferences, and PSK modulation is more difficult to carry out from the point of view of circuit technology. In contrast to the known applications of the above-mentioned methods, in the case of use in microphones, the crucial factor is that the modulated signal has to be separated from an analog signal, the audio signal. Even if the frequency-modulated signal is only fed into the conductor 2, which is not intended for the audio signal, the capacitive coupling between the two conductors 1, 2 of the audio cable causes an interference in the audio signal. The capacitive coupling depends on the constitution and the length of the audio cable. Therefore, filtering the interference is difficult in spite of the fact that the control signal is known.

[0044] In the microphone, the frequency-modulated voltage is separated by means of a filter 37, for example, a band pass filter, from the audio signals, and the control information contained therein is evaluated by means of a control electronics 39, for example a microcontroller or a CPLD (Complex Programmable Logic Device). Cable conductor 2 is uncoupled through a capacitance 43 from the grounding. The control electronics 39 is connected in front of a comparator 38 which functions as a voltage comparator. Commands through the outputs of the control electronics 39, for example, reach a power supply circuit 11, as can be seen in Figs. 1 and 2, the audio amplifier 10, processors, control electronics 39, A/D or D/A converters 44, 46, etc.

[0045] The frequency modulation on the two audio lines 1, 2 is carried out in the remote control unit 55, which is preferably located close to the mixing table. In the remote control unit 55, on the one hand, the carrier frequency has to be applied in the direction toward the microphone 54, and, on the other hand, in the direction of the mixing table, all modulation frequencies have to be suppressed. Only the audio signals that come from the microphone 54 must be transmitted. To make the suppression of the modulation frequencies simpler, the modulation is carried out on both audio lines 1, 2 with the same level. In the remote control unit 55, as a result, the frequency-modulated signal appears as a common mode signal for the input-difference amplifier 42 and thus it can, as a common mode signal, be appropriately suppressed. In a second variant of the remote control, the frequency modulation occurs only in the line that does not transit an audio signal, that is, line 2. In the direction toward the mixing table, in this variant, the frequency-modulated signals can be eliminated by filtering through a low-pass filter 41. The phantom power unit 31, including the feeder resistances 32, 33 as well as difference amplifiers 42 and low pass filters, do not have to be integrated, as shown in Fig. 5, in the remote control unit. For example, they can also be provided in the mixing table.

[0046] To ensure, during the transmission of a control

signal from the remote control unit 55 to the microphone 54, that the control signal has in fact reached the control electronics 39, the latter sends in response to the control signal a data-acknowledge message to the remote control unit 55. The data-acknowledge message can also be a frequency-modulated signal. The data-acknowledge message for the function of the remote control is not absolutely necessary; however, it increases the reliability of the system at the cost of additional electronics.

[0047] The above described method for remote control is of course not restricted to capacitor microphones, since the individual power receivers of any kind of microphones, in particular dynamic microphones, can be operated by means of a phantom power supply.

[0048] Fig. 6 shows a capacitor microphone according to the invention, in which the regulation of the polarization voltage occurs by means of a two-step control regulation loop. Here, a second digital regulation loop 47 is overlain above an internal analog regulation loop 48. As a result, it becomes possible to generate a well-regulated, interference-free polarization voltage on the microphone capsule 9.

[0049] A preferably frequency-modulated signal with control information, which is transmitted through the cable conductors, which are also connected to the phantom power unit 31, reaches the control electronics 39 through a filter 37 and a comparator 38. Detailed presentations concerning the remote control of microphones according to the invention have already been provided above. See also, in particular, Fig. 5. The control of the control electronics 39 can also occur via regulating devices or operating elements on the microphone itself. It is also possible, that the control electronics is connected to a radio or an infrared interface for the purpose wireless transmission or to a cable interface. The desired value obtained in the control signal for the polarization voltage is delivered to the analog regulation 48 via a D/A converter 46 by the control electronics 39. Instead of a D/A converter, one can also use a pulse-width modulation circuit (PWM). Although PWM circuits have lower conversion rates, they are inexpensive and therefore are very appropriate for adjusting constant levels in these converters. Fig. 7 is an embodiment example, showing how the control electronics 39, which is for example a microcontroller or a CPLD, plus D/A converter or PWM 46 acts on an analog regulation loop 48. Many analog regulation loops are known in the state of the art, and, for a person skilled in the art who knows the invention, it is easy to choose dimensions for such a regulation loop. As schematically represented in Fig. 6, the analog regulation loop 48 comprises a regulation circuit 56 and a voltage divider 49, 50. The details of the regulation circuit 56 or of the overall analog regulation loop 48 are shown in Fig. 7.

[0050] The analog regulation loop 48 is preferably supplied by a power supply circuit 11 with an unregulated voltage of approximately 100-120 V. The DC/DC converter can be of the same type as described above, or represented in Figs 1 and 2. The resistances 5 and 6 are

the feeder resistances in the microphone. They are used for uncoupling the power supply of the microphone from the output of the audio amplifier 10. The resistances 5 and 6 are identical in size to preserve the symmetry of the lines 1 and 2.

[0051] The invention is of course not restricted to phantom power supplied capacitor microphones. The energy supply for the individual power receivers of the capacitor microphone can, for example, also be carried out by a battery located in the microphone.

[0052] The desired value provided by the D/A converter or the PWM 46, or, more precisely, the correction value for the polarization voltage, is compared with the actual value via the operation amplifier 52. The desired value is calculated from calibration data measured during the manufacture of the microphone and programmed into the control electronics. As a reference value for this calculation, one uses either an exact reference voltage 45 on the conductor or a reference voltage programmed during the print measurement into the control electronics. The reference voltage 45 can be made available, for example, by a logic supply 24. Such a logic supply 24, which is preferably fed by a DC/DC converter 11, not shown in Fig. 7, is shown in Figs. 1 and 2.

[0053] To suppress the undesired influence of high-frequency interferences on the analog regulation loop 48, a preferred embodiment provides a low pass filter 51 between D/A converter or PWM 46 and the input of the analog regulation loop 48, as represented in Fig. 7. The actual value generated by the analog regulation loop 48 is taken up through a voltage divider 49, 50 and applied via an impedance converter 53 to the inverted input of the operation amplifier 52. The feedback line plus impedance converter is not included in the schematic drawing of Fig. 6. At the same time, this voltage is also applied to the input of an A/C converter 44 of the digital regulation loop 47. The resulting digital signal is made available to the control electronics 39 as feedback. As a result, the outer digital regulation loop 47 is closed. In Fig. 7, the voltage divider, through which the actual value is taken up, is represented by the resistances 49, 50. As indicated in Fig. 7, A/D converter 44, control electronics 39, as well as D/A converter 46 can also be integrated in a single component.

[0054] As output of the analog regulation 48, one obtains the regulated polarization voltage applied to the microphone capsule 9 via a high-ohm resistance 8. The correction voltages or the corresponding correction factors that are required to calculate a regulated and interference-free polarization voltage can correspond to different settings, which reflect certain sensitivities, guide characteristics, and aging parameters; they can be stored in a memory provided in the control electronics 39, and called up at any time.

[0055] These correction factors can later be changed by remote control with a closed microphone (for example, in the Service Department or by the distributor, and also possibly by the customer). Besides the possible correc-

tion of microphone properties resulting from aging or from the replacement of the microphone capsule, an on-site custom-specific tuning of the microphone is thus also possible.

[0056] The invention is not limited to the individual embodiment examples. Naturally, it is also conceivable to use microphones in which all or at least some of the above-described circuits are combined. For example, a remote control for all remote-controllable components can be provided in the microphone; also, the power supply circuit 11 can supply all conceivable power receivers in the microphone.

15 Claims

1. Microphone comprising at least one microphone capsule (9), at least one audio amplifier (10), and at least one additional power receiver, selected from the group of processors, control electronics (39), A/D and D/A converters (44, 46), LED displays (25), and whose energy supply occurs from a phantom power unit (31) through the cable conductors (1, 2) of the audio cable, the so-called phantom power supply, and which microphone comprises a power supply circuit (11) for the individual power receivers, wherein the power supply circuit (11) comprises a control unit (12) that converts the direct current transmitted via the cable conductors (1, 2) of the audio cable into an alternating current, a transformer (14) connected to the control unit (12), and supply loops (15, 16, 17) for the individual power receivers, where the supply loops (15, 16, 17) are inductively coupled by means of separate windings on the transformer (13) to the alternating current generated by the control unit (12) and to each other, **characterized in that** the power supply circuit (11) is provided on its input side with a high-ohm constant-current generator (13), so that the power supply circuit with respect to the phantom power unit (31) forms a constant-current sink.
2. Microphone according to Claim 1, **characterized in that** the internal resistance of the power supply circuit (11) is essentially identical to the internal resistance of the phantom power unit (31).
3. Microphone according to one of Claims 1-2, **characterized in that** at least one power receiver with constant-current consumption, is series-connected with the power supply circuit (11).
4. Microphone according to one of Claims 1-3, **characterized in that**, in the supply loop (16) for the microphone capsule (9), a remote controllable regulation circuit (47, 48) is provided for setting the polarization voltage.
5. Microphone according to one of Claims 1-4, **char-**

acterized in the phantom power unit (31) is configured to supply a voltage being exceeded by the supply voltage of the audio amplifier (10).

6. Microphone according to one of Claims 1-4, **characterized in that** the supply voltage of the audio amplifier (10) is symmetrical with respect to the grounding.

Patentansprüche

1. Mikrofon, enthaltend zumindest eine Mikrofonkapsel (9), zumindest einen Audioverstärker (10) und zumindest einen weiteren Leistungsabnehmer, ausgewählt aus der Gruppe, die Prozessoren, einen Mikrocontrollern (39), A/D- bzw. D/A-Wandlern (44, 46) und LED-Anzeigen (25) umfasst, und dessen Energieversorgung aus einer Einheit zur Phantomspeisung (31) über die Kabeladern (1, 2) des Audiokabels erfolgt, die sogenannte Phantomspeisung, und wobei das Mikrofon eine Spannungsversorgungsschaltung (11) der einzelnen Leistungsabnehmer umfasst, wobei die Spannungsversorgungsschaltung (11) eine Steuerungseinheit (12) enthält, die den Gleichstrom, der über die Kabeladern (1, 2) des Audiokabels übertragen wird, in Wechselstrom umwandelt, mit einem Transformator (14), der mit der Steuerungseinheit (12) verbunden ist, und Versorgungskreise (15, 16, 17) für die einzelnen Leistungsempfänger, wobei die Versorgungskreise (15, 16, 17) induktiv durch separate Windungen auf dem Transformator (13) sowohl mit dem durch die Steuerungseinheit (12) erzeugten Wechselstrom, als auch untereinander gekoppelt sind, **dadurch gekennzeichnet, dass** dem Spannungsversorgungsschaltung (11) einseitig mit einem hochohmigen Gleichstromgenerator (13) versehen ist, so dass der Versorgungsstromkreis in Bezug auf die Phantomspeisung (31) eine Konstantstromsenke bildet.
2. Mikrofon nach Anspruch 1, **dadurch gekennzeichnet, dass** der innere Widerstand des Spannungsversorgungsschaltung (11) im Wesentlichen gleich dem inneren Widerstand der Phantomspeisung (31) ist.
3. Mikrofon nach einem der Ansprüche 1 bis 2, **dadurch gekennzeichnet, dass** zumindest ein Gleichstrom beziehender Leistungsempfänger mit dem Spannungsversorgungsschaltung (11) in Serie geschaltet ist.
4. Mikrofon nach einem der Ansprüche 1 bis 3, **dadurch gekennzeichnet, dass** im Versorgungskreis (16) der Mikrofonkapsel (9) eine fernsteuerbare Regelschaltung (47, 48) zur Einstellung der Polarisationsspannung vorgesehen ist.

5. Mikrofon nach einem der Ansprüche 1 bis 4, **dadurch gekennzeichnet, dass** die Phantomspeisung (31) so konfiguriert ist, dass sie eine Versorgungsspannung liefert, die von der Versorgungsspannung des Audioverstärkers (10) übertroffen wird.

6. Mikrofon nach einem der Ansprüche 1 bis 4, **dadurch gekennzeichnet, dass** die Versorgungsspannung des Audioverstärkers (10) symmetrisch in Bezug auf die Erdung ist.

Revendications

1. Microphone comprenant au moins une pastille de microphone (9), au moins un amplificateur audio (10), et au moins un récepteur d'alimentation supplémentaire électrique, sélectionné dans le groupe constitué par des processeurs, des circuits de commande (39), des convertisseurs A / D et D / A (44, 46), des dispositifs d'affichage à LED (25), et dont l'alimentation provient d'une unité d'alimentation fantôme (31) par l'intermédiaire des conducteurs de câble (1, 2) du câble audio, ce qu'il est convenu d'appeler une alimentation fantôme, lequel microphone comprend un circuit d'alimentation (11) pour les différents récepteurs d'alimentation, dans lequel le circuit d'alimentation (11) comprend une unité de commande (12) qui convertit le courant continu transmis par l'intermédiaire des conducteurs de câble (1, 2) du câble audio, en un courant alternatif, un transformateur (14) connecté à l'unité de commande (12), et des boucles d'alimentation (15, 16, 17) pour les différents récepteurs d'alimentation, dans lequel les boucles d'alimentation (15, 16, 17) sont couplées par induction au moyen d'enroulements séparés sur le transformateur (13), au courant alternatif généré par l'unité de commande (12), et les unes aux autres, **caractérisé en ce que** le circuit d'alimentation (11) est doté, de son côté entrée, d'un générateur à courant constant à haute impédance (13), de telle sorte que le circuit d'alimentation forme, vis-à-vis de l'unité d'alimentation fantôme (31), un récepteur à courant constant.
2. Microphone selon la revendication 1, **caractérisé en ce que** la résistance interne du circuit d'alimentation (11) est sensiblement identique à la résistance interne de l'unité d'alimentation fantôme (31).
3. Microphone selon la revendication 1 ou la revendication 2, **caractérisé en ce qu'**un récepteur d'alimentation au moins qui présente une consommation à courant constant, est connecté en série avec le circuit d'alimentation (11).
4. Microphone selon l'une quelconque des revendica-

tions 1 à 3, **caractérisé en ce qu'il** est prévu, dans la boucle d'alimentation (16) de la pastille de microphone (9), un circuit de régulation qui peut être commandé à distance (47, 48), de façon à fixer la tension de polarisation.

5

5. Microphone selon l'une quelconque des revendications 1 à 4, **caractérisé en ce que** l'unité d'alimentation fantôme (31) est configurée de façon à fournir une tension dépassée de la tension d'alimentation de l'amplificateur audio (10).

10

6. Microphone selon l'une quelconque des revendications 1 à 4, **caractérisé en ce que** la tension d'alimentation de l'amplificateur audio (10) est symétrique par rapport à la masse.

15

20

25

30

35

40

45

50

55

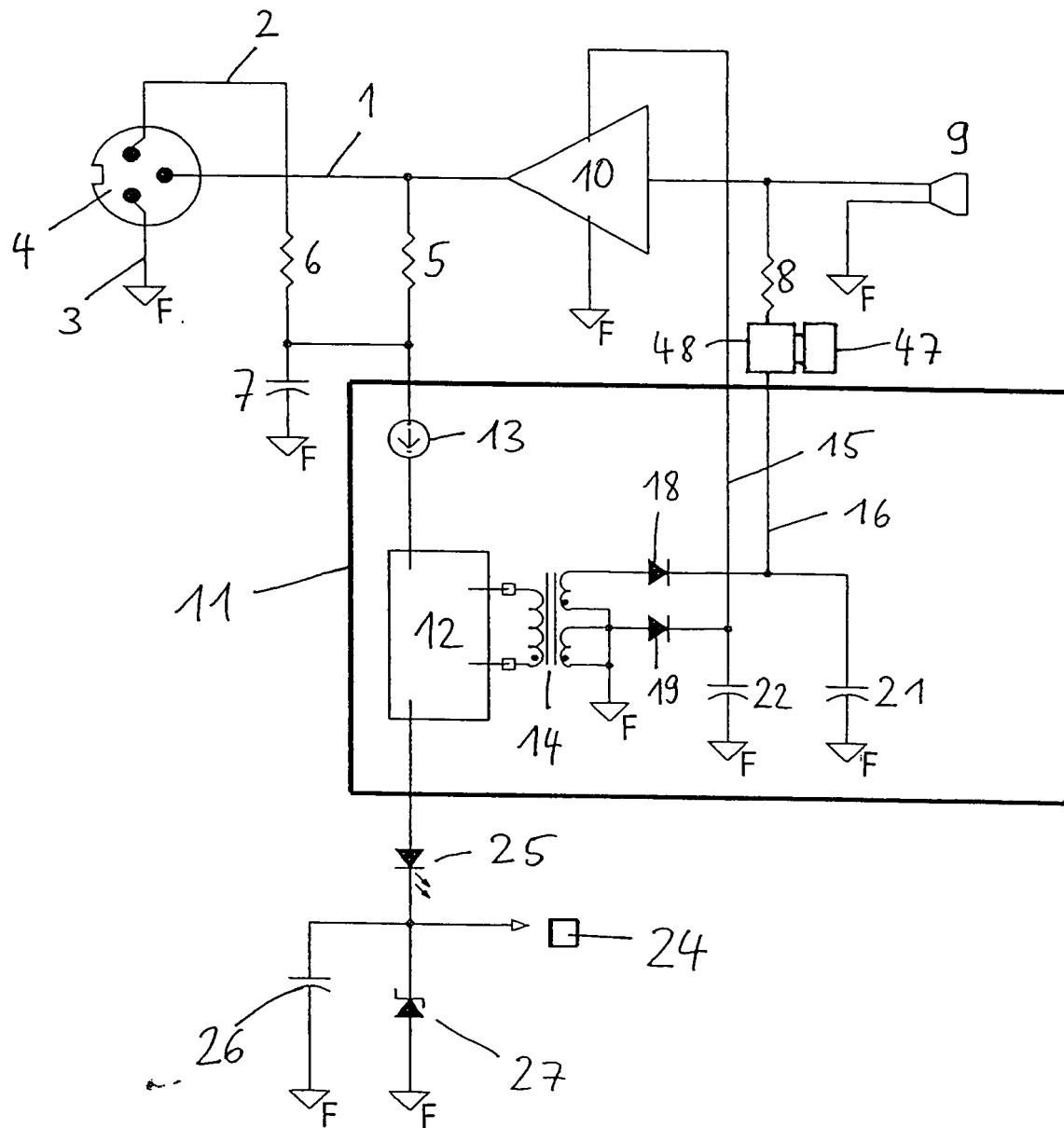

Fig. 2

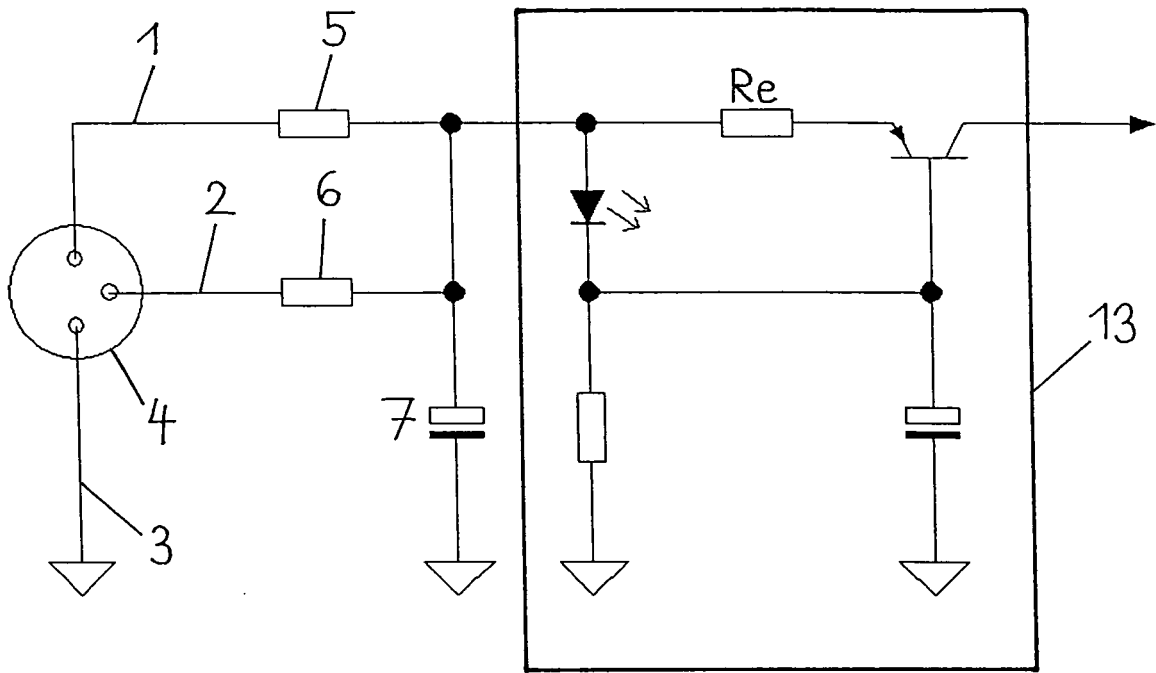

Fig. 3

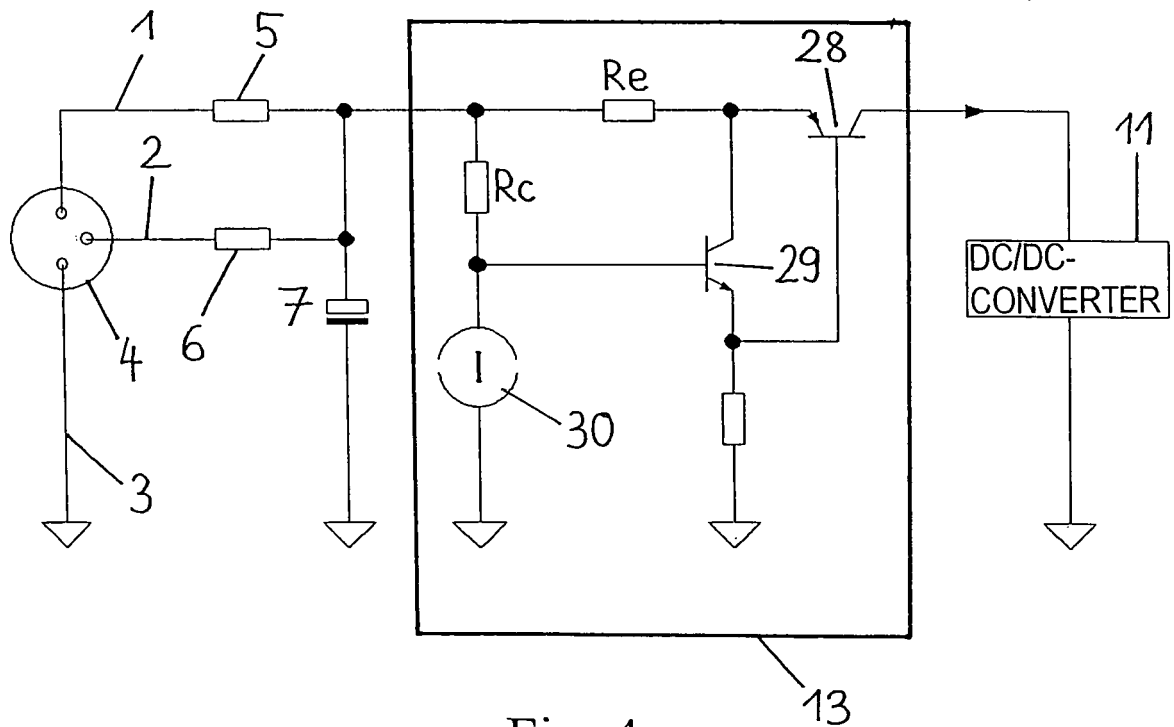

Fig. 4

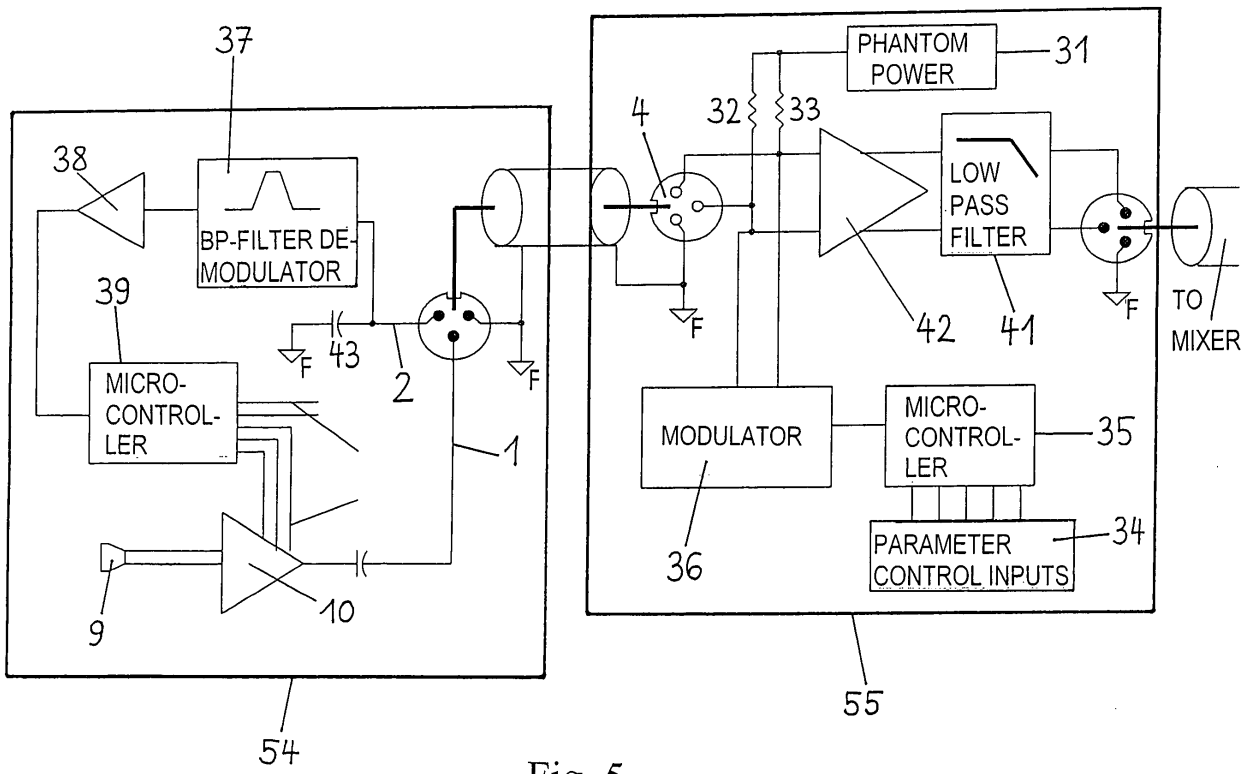

Fig. 5

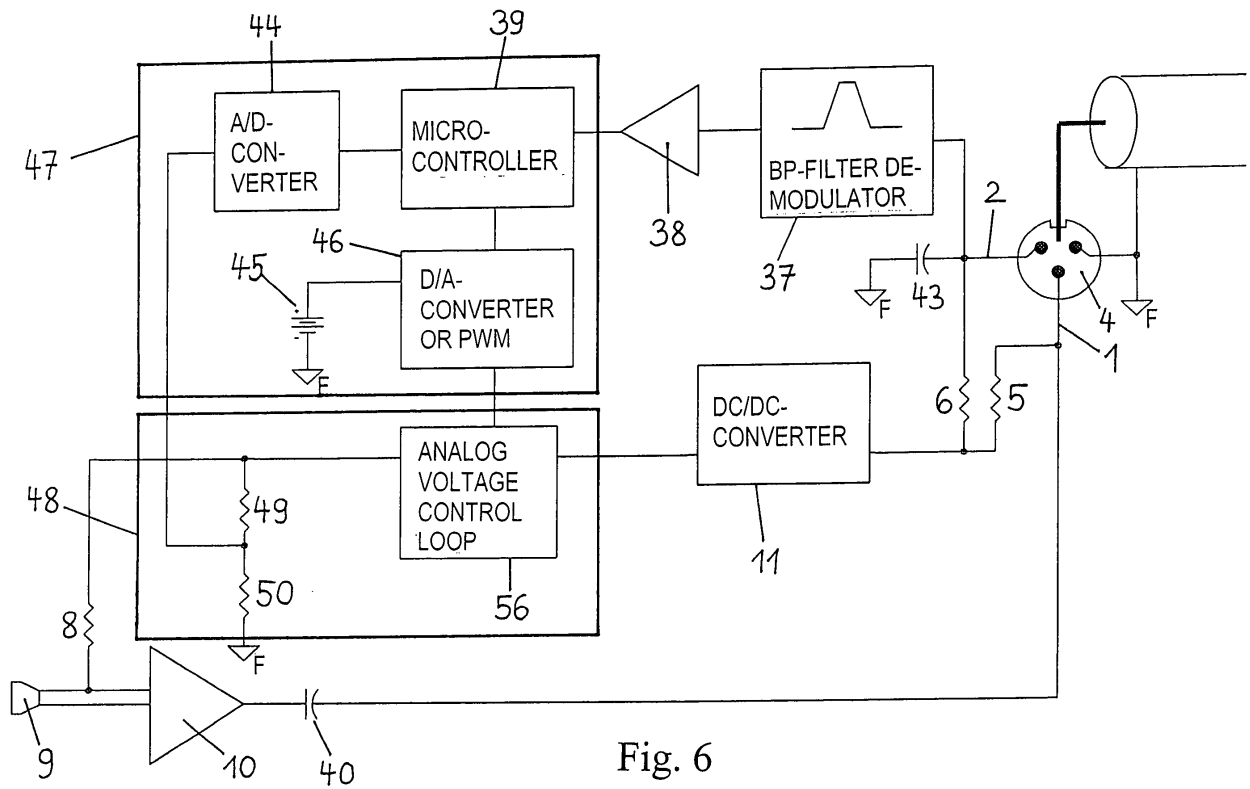

Fig. 6

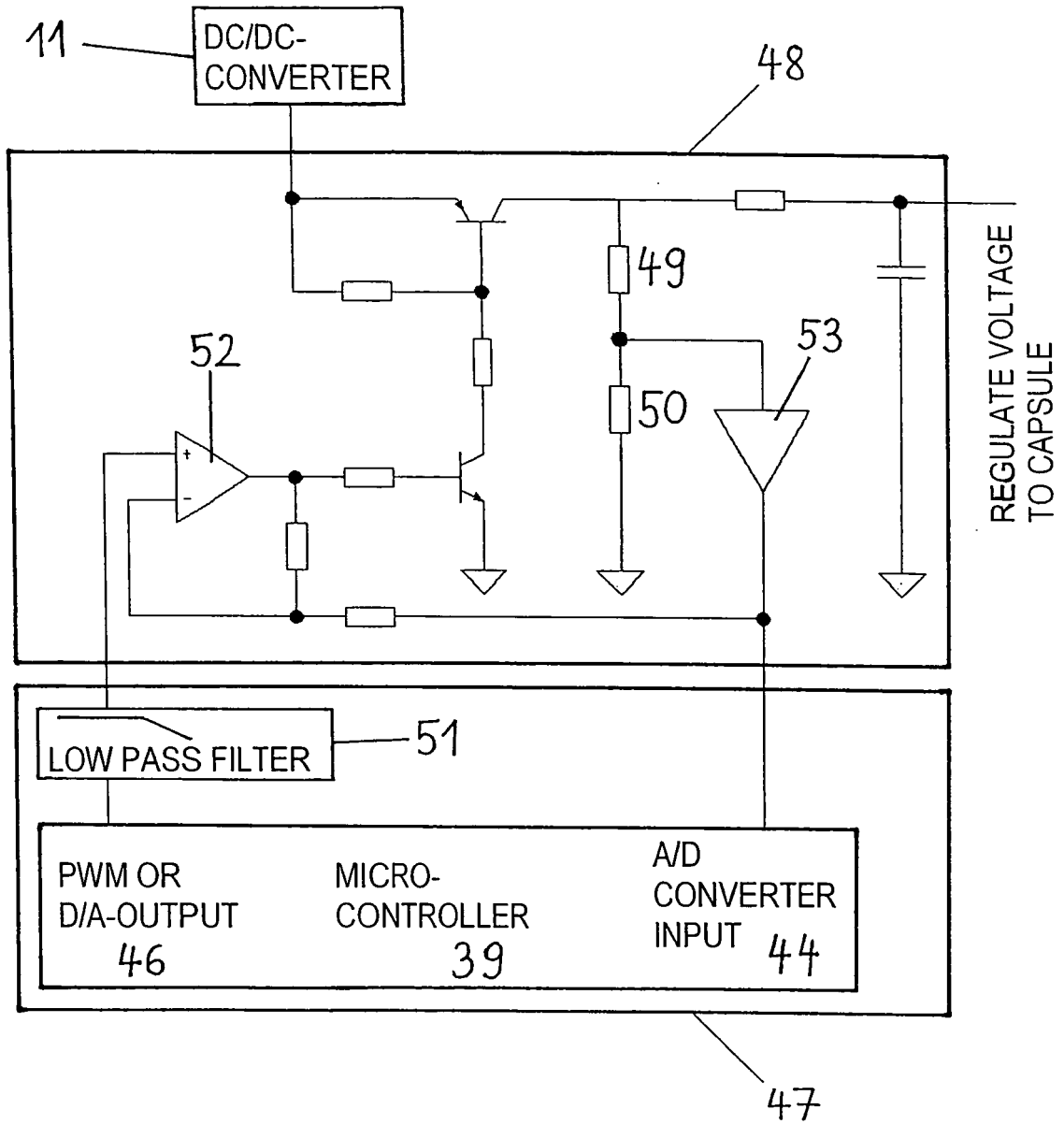

Fig. 7

REFERENCES CITED IN THE DESCRIPTION

This list of references cited by the applicant is for the reader's convenience only. It does not form part of the European patent document. Even though great care has been taken in compiling the references, errors or omissions cannot be excluded and the EPO disclaims all liability in this regard.

Patent documents cited in the description

- DE 3933870 A1 [0006] [0013]
- US 4541112 A [0013]