

June 30, 1959

H. G. BAUER  
MULTIPLE TREMULANT FOR TREBLE TONES  
IN ELECTRONIC MUSICAL INSTRUMENTS

2,892,373

Filed May 19, 1955

2 Sheets-Sheet 1

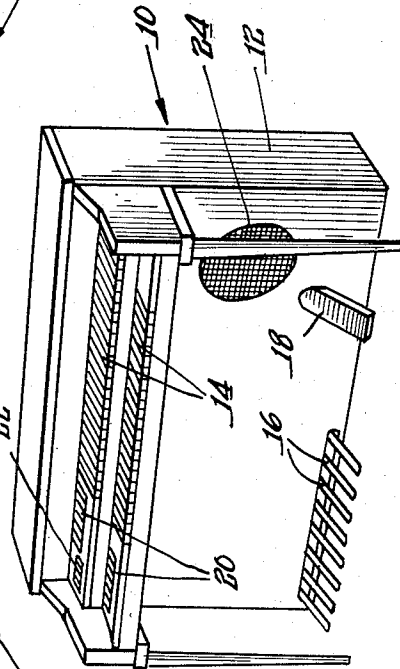
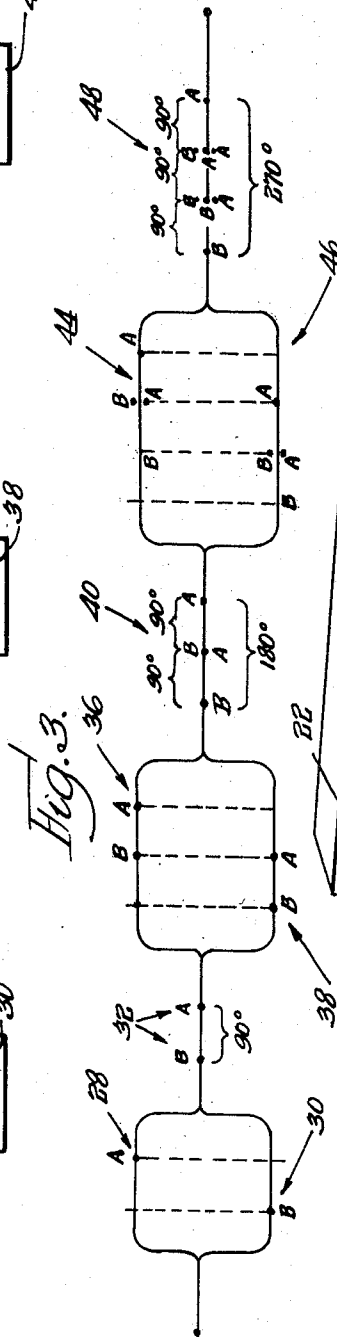
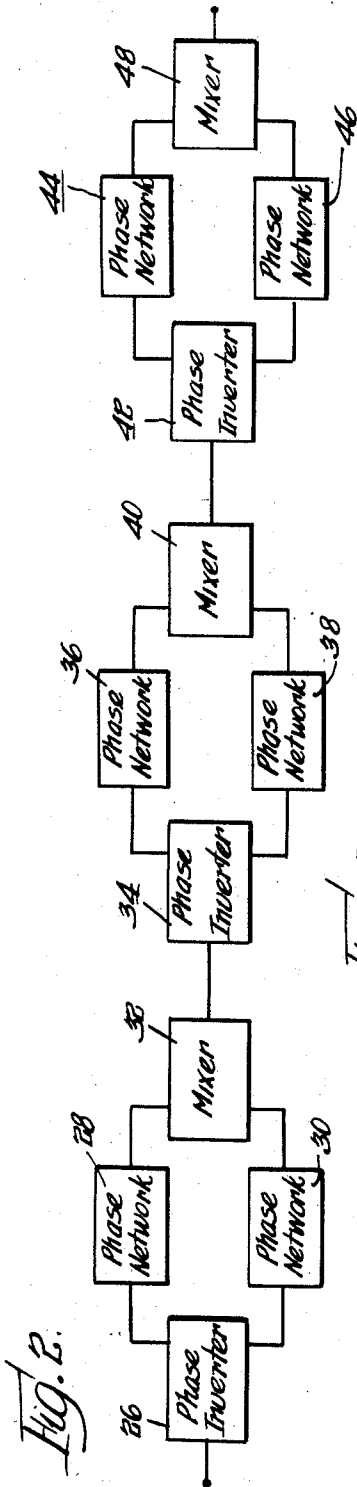

INVENTOR.  
Howard G. Bauer  
BY: *Olson & Traylor*  
attys.

June 30, 1959

H. G. BAUER  
MULTIPLE TREMULANT FOR TREBLE TONES  
IN ELECTRONIC MUSICAL INSTRUMENTS

2,892,373

Filed May 19, 1955

2 Sheets-Sheet 2

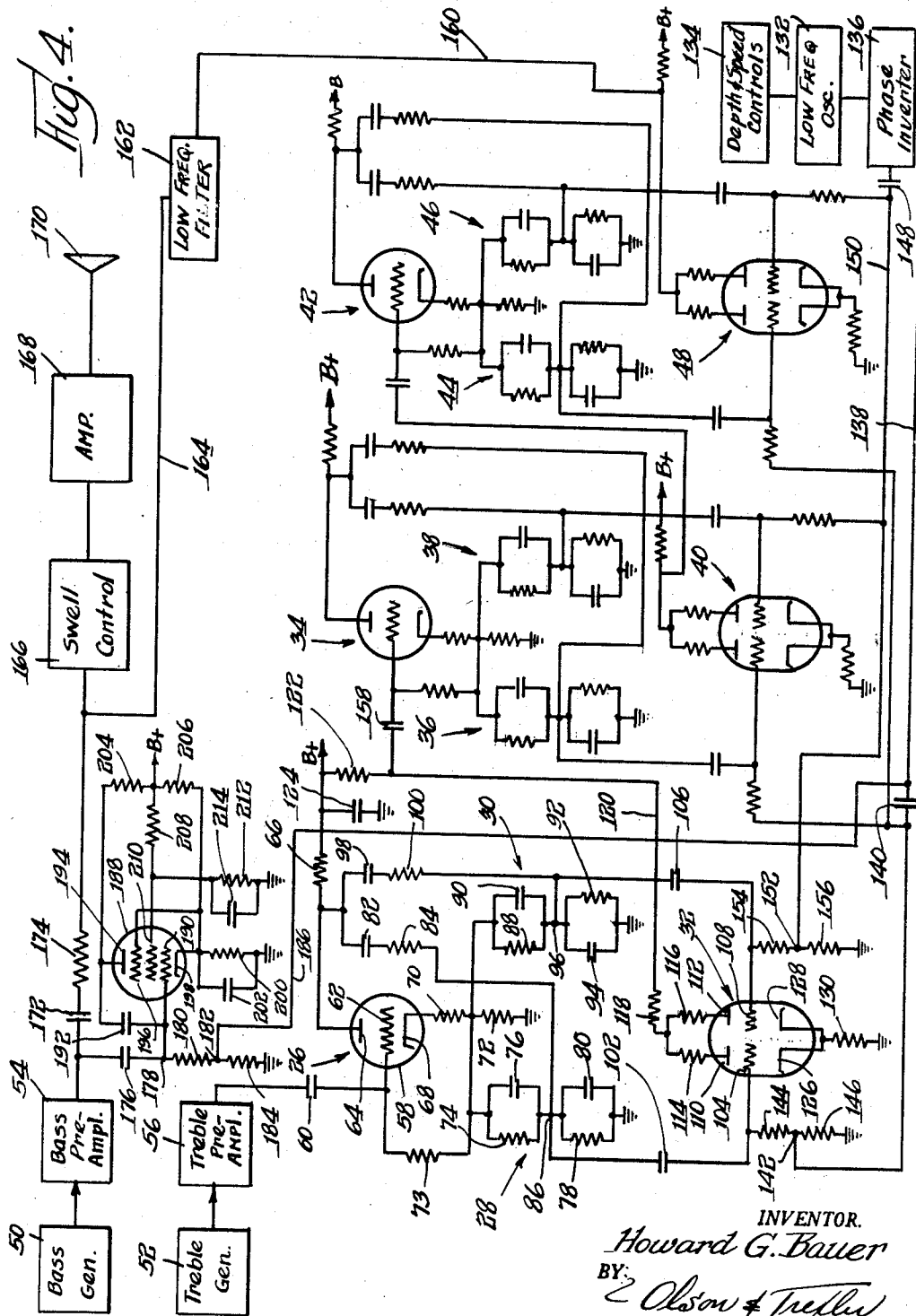

INVENTOR.  
Howard G. Bauer  
BY: Olson & Trefler  
attys.

1

2,892,373

**MULTIPLE TREMULANT FOR TREBLE TONES IN ELECTRONIC MUSICAL INSTRUMENTS**

Howard G. Bauer, Tonawanda, N.Y., assignor to The Rudolph Wurlitzer Company, North Tonawanda, N.Y., a corporation of Ohio

Application May 19, 1955, Serial No. 509,530

6 Claims. (Cl. 84-1.25)

This invention is concerned with an electronic tremulant for an electronic organ, and comprises a continuation in part of my copending application Serial No. 368,427, filed July 16, 1953, and entitled "Organ Tremulant."

Tremulant effects in musical instruments can be produced by various means. The normal musical tremulant is a pure pitch variation such as is achieved by a violinist's hand. Various mechanical devices have been utilized heretofore to produce tremulant effects by means of pitch variations in electronic organs. Mechanical devices in musical instruments such as electronic organs are undesirable as they are susceptible to a certain amount of wear, and wear is bound to be accompanied by electrical noise. Completely electronic tremulants in electric organs heretofore have been devices causing a volume variation, rather than a pitch variation. Volume variation is satisfactory to produce a tremulant, or more specifically, in the case of volume variation, a vibrato, in the case of bass tones. In the case of treble tones, however, a volume vibrato is quite monotonous and is entirely unsatisfactory to the musically trained or adept ear.

Accordingly, it is an object of this invention to provide a volume vibrato of electronic nature for the bass tones of an electronic organ and a tremulant of electronic origin producing a pitch variation in the treble tones.

It further is an object of this invention to provide an electronic tremulant for an electronic organ in a multiplicity of steps wherein each step varies the phase up to 90°.

It further is an object of this invention to provide an electronic circuit in an electronic organ alternatively producing a tremulant or reverberation.

Other and further objects and advantages of the present invention will be apparent from the following description when taken in connection with the accompanying drawings, wherein:

Fig. 1 is a perspective view of an electronic organ constructed in accordance with the principles of my invention;

Fig. 2 is a block diagram illustrating the treble tremulant;

Fig. 3 is a diagram illustrating the block diagram of Fig. 2, and

Fig. 4 is a diagram partially comprising a block diagram and partially comprising a schematic wiring diagram of the organ.

Referring now in greater detail to the drawings, wherein like numerals are used to identify similar parts throughout, there is shown in Fig. 1 an electronic organ 10 embodying the principles of the invention. The organ 10 includes a cabinet 12 having suitable keyboards 14 and a pedal clavier 16. The organ also is provided with a volume control or swell pedal 18, a plurality of stop tablets 20, various control switches 22, and a loudspeaker 24.

It is thought that the electronic tremulant best will be understood with reference first to the diagrams of Figs. 2 and 3. Thus, in Fig. 2 the signal is applied first to

2

a phase inverter 26 having associated therewith a pair of phase shifting networks 28 and 30 producing similar signals varying in phase by substantially 90°. At 28 and 30 in Fig. 3 it will be seen that two signals A and B are shown in the respective phase networks. These signals are combined in a mixer 32 (Fig. 2) to provide signals B and A which vary in phase by 90° relative to one another as may be seen in Fig. 3. Suitable control is provided for the mixer 32 as hereinafter will be described relatively to emphasize one or the other of the signals A and B at a low cyclic rate to provide a phase shift tremulant, or the signals may be equally emphasized to provide reverberation.

The output of the mixer 32 is applied to a phase inverter 34 having a pair of phase shifting networks 36 and 38 associated therewith, the outputs of these two phase shifting networks being applied to a mixer 40. Reference to Fig. 3 indicates that this produces a signal BA leading another signal BA by 90°. Thus, in the mixer there is a signal B which is 180° from a signal A. Simultaneously, there is a signal B which is 90° out of phase with one signal A and one signal B, and yet another signal A which is 90° out of phase with one signal B and one signal A. When suitable control is provided as hereinafter will be discussed, the emphasis may be shifted from the first signal B through the signal BA to the signal A, and back again to provide a tremulant having a phase shift up to 180°, and simultaneously having phase shifts of 90° due to the intermediate BA signal. In view of what has been said heretofore, it will be appreciated that a reverberation effect could be obtained by equally emphasizing all of the signals.

The output of the mixer 40 is applied to a phase inverter 42 having two output connections respectively connected to a phase shifting network 44 and a phase shifting network 46, the output of the networks 44 and 46 being applied to a mixer 48. Reference to Fig. 3 at 44 and 46 indicates that there are produced two similar signals B(BA)A, the two signals being displaced 90°. At 48 it will be apparent that there is a signal B which is displaced 270° from the signal A. Furthermore, the first signal B is displaced 90° from a signal BBA, and at 90° after that there is a signal BAA. By relatively varying the emphasis in the mixer 48, the phase can be shifted through 270° from the first signal B to the last signal A, simultaneously producing 90° shifts through the various combination signals. Alternatively, a reverberation can be obtained by equally emphasizing all of the signals.

It will be appreciated that additional phase inverter and phase shifting networks and mixers could be utilized in a series of practically infinite length to produce a phase shift of any degree of magnitude. This phase shift will be of 90° or any multiple thereof, and when multiples thereof are obtained, there are simultaneously sub-phase shifts of 90° each. The result is to provide an extremely pleasant and realistic phase shift tremulant.

Referring now more particularly to Fig. 4, there is indicated generally at 50 a plurality of bass tone generators. There is also indicated a plurality of treble tone generators 52. Preferably the bass and treble tone generators take the form of vibrating metallic reeds. As explained in U.S. Patent No. 2,015,014 to Hoschke, remarkably realistic organ tones can be generated by using a vibrating reed and an associated pick-up as the plates of a variable capacitor which varies in capacity with the spacing between the reed and pick-up, and hence in accordance with the vibrations of the reeds. The reed is vibrated by means such as an airblast. In the present invention, all of the reeds preferably are continuously vibrated, and suitable electrical connections are made to the various reeds and associated pick-ups when it is desired for particular musical notes to play. The bass

tone generators 50 are connected to a bass preamplifier 54, while the treble tone generators are connected to a treble preamplifier 56.

The phase inverter 26 is illustrated as being a triode tube 58 with the output of the treble preamplifier 56 directly connected through a capacitor 60 to the grid 62 of the tube 58. The plate 64 of the tube is connected through a load resistor 66 to a suitable source of B+, while the cathode 68 is grounded through a relatively low valued resistor 70 and a resistor 72 of the same order of magnitude as the resistor 66. The grid 62 also is connected by means of a resistor 73 to the phase shifting network 28 comprising a resistor 74 and capacitor 76 connected in parallel, the parallel circuit being connected in series with another parallel connected resistor 78 and capacitor 80, the latter parallel combination being grounded. The phase shifting network 28 also includes a capacitor 82 connected to the plate 64, and a resistor 84 connected to the capacitor 82 and to the junction 86 between the two parallel resistance-capacitance circuits.

The phase shifting network 30 is similar to the phase shifting network 28, comprising a parallel resistor 88 and capacitor 90 connected to the grid 62, and also connected to another parallel resistor 92 and capacitor 94 through a junction 96, the last mentioned parallel circuit being grounded. The phase shifting network 30 also includes a capacitor 98 connected to the plate 64 and in series with a resistor 100, the resistor also being connected to the junction 96.

The mixer 32 is illustrated as being a dual triode tube. The junction 86 is connected through a capacitor 102 to one of the grids 104 of the dual triode, while the junction 96 is connected through a capacitor 106 to the other grid 108 of the dual triode. The plates 110 and 112 are respectively connected to resistors 114 and 116 of equal value, and these two resistors are connected in parallel to a load resistor 118 which leads through a line 120 and a load resistor 122 and capacitor 124 to the B+ source previously referred to. The cathodes 126 and 128 are connected in parallel to a grounded cathode resistor 130.

The two phase shifting networks 28 and 30, although similar in appearance, differ slightly in value. As a specific example, the capacitor 76 may be a .0001 microfarad capacitor while the corresponding capacitor 90 is .00047 microfarad. Both of the resistors 78 and 88 are 360,000 ohms. The capacitor 80 may be .0002 microfarad while the corresponding capacitor 94 may be .00075 microfarad, both of the resistors 78 and 92 being 180,000 ohms. Similarly, the capacitor 82 may be .00056 microfarad, while the corresponding capacitor 98 is .00025 microfarad. Both of the resistors 84 and 100 are 62,000 ohms.

In addition to the grid connections previously indicated for the mixer 32, there are grid connections for effecting a tremulant control function. There is provided for the circuit a low frequency oscillator 132 indicated simply as a block diagram. The frequency of the low frequency oscillator is a sub-audio frequency, and is adjustable. Typical values would range from 5.7 cycles per second through 6.7 cycles per second. Depth and speed controls 134 are connected to the low frequency oscillator to vary the oscillating frequency thereof, and also to vary the intensity of oscillation. The output of the low frequency oscillator 132 is connected to a phase inverter 136 for providing two similar low frequency oscillation signals 180° out of phase with one another. One of the output connections of the phase inverter extends through a lead wire 138 and a capacitor 140 to a junction 142 between a series connected pair of resistors 144 and 146 grounding the grid 104. The other output of the phase inverter 136 is connected through a capacitor 148 to a line 150, and this line leads to a junction 152 between a pair of series connected resistors 154 and 156 grounding the grid 108 of the mixer.

The output of the mixer 32 is connected by means of a

wire or line 120 previously mentioned to a capacitor 158 connected to the grid or input connection of the phase inverter 34. This phase inverter is similar to the one previously described, and extended description thereof therefore is believed to be unnecessary. Similarly, the phase shifting networks 36 and 38 are respectively similar to the phase shifting networks 28 and 30 previously discussed, these phase shifting networks providing plate and cathode output circuits from the phase inverter tube 34 which are substantially 90° out of phase, and these phase shifting networks are connected to the input connections of the mixer 40 which again conveniently comprises a dual triode connected in the manner previously indicated.

The output of the mixer 40 is connected to the input of the phase inverter 42, and this again is illustrated conveniently as being a triode tube. The phase shifting networks 44 and 46 are similar to those previously described, and are similarly connected to the mixer 48, which again preferably comprises a dual triode tube.

The low frequency oscillator 132 is connected through the phase inverter 136 to the mixers 40 and 48 in parallel with the mixer 32 so as to act on these mixers in the same manner as on the mixer 32.

It is within the contemplation of this invention that the series of phase shifters could be continued practically indefinitely. However, in the present instance, the output of the mixer 48 is connected by means of a wire 160 to a low frequency filter 162 designed to eliminate the low frequency oscillations so that only the treble signals will pass through the low frequency filter to a connecting wire 164 leading to a swell control 166 controlled by the swell pedal 18 previously mentioned. The output of the swell control 166 is connected to an amplifier 168 which preferably includes a push-pull output stage and which actuates a loudspeaker 170.

The output of the bass preamplifier 54 is connected through a series capacitor 172 and resistor 174 to the swell control 166. In addition to this, the output of the bass preamplifier is shunted by a capacitor 176 connected at a junction 178 to a resistor 180, the latter being connected in turn at a junction 182 to a resistor 184, the resistor 184 being grounded. A line 186 leads from the junction 182 to the line 138 carrying the output of the low frequency oscillator on one side of the phase inverter 136.

The input of a reactance tube 188 is connected to the junction 178. The control grid 190 of the reactance tube is directly connected to the junction 178, and the control grid also is connected by a capacitor 192 to the plate 194 of the reactance tube. The suppressor grid 196 is directly connected to the cathode 198 in accordance with conventional practice, the cathode being grounded by the usual parallel connected cathode resistor 200 and capacitor 202. The plate 194 also is connected to a source of B+ through a resistor 204, and the source of B+ further is connected through a resistor 206 to the cathode 198. Additionally, the B+ is connected through a resistor 208 to the screen grid 210, and the screen grid is grounded through a parallel circuit comprising a resistor 212 and a capacitor 214. The input of the reactance tube 188 varies in accordance with the low frequency oscillation imposed thereon. More specifically, the input capacitance varies, and the tube 188 therefore acts as a variable capacitor shunting the bass signal. As a result, the bass signal as applied to the swell control varies in amplitude at the rate of the low frequency oscillator. As previously has been noted, this provides a vibrato which is satisfactory with bass signals.

Operation of the phase shift tremulant on the treble tones is as follows. The two inputs to the grids 104 and 108 of the mixer tube 32 vary substantially linearly with the frequency of the treble tone oscillations, but maintain a constant phase angle relation between one another. Mathematical relations can be, and have been, worked

out explaining the phase shifting. However, the mathe-

matical relations do not clarify the end result any more than the simple explanation following immediately hereafter.

At low frequencies the impedance of the capacitor 82 is very high, and practically the entire transmission from the phase inverter tube 58 takes place through the resistance 74, the capacitor 76 having practically infinite impedance at low frequencies. At higher frequencies the capacitor 82 passes the oscillations more freely than the resistor 74, and 180° of phase shift takes place in the voltage between the output terminals. On a further increase in frequency, the impedance of the capacitor 82 becomes low relative to that of the resistor 84, and the latter controls transmission through this branch. At still higher frequencies, the impedance of capacitor 76 gradually reduces, and this capacitor finally passes oscillations more freely than the resistor 78, thereby producing a further 180° phase shift. Thus, as the frequency varies from the low end of the range to the high end, a complete 360° phase shift takes place in the voltage of the output terminals. The output of the phase shifting network 30 varies similarly to that of the phase shifting network 28 just described, except that the different values are chosen for the circuit elements as heretofore described and set forth by way of illustrative example so that the outputs of the phase shifting networks are supplied to the grids 104 and 108 at all times substantially 90° apart. The outputs, of course, are identical except for this phase difference.

The components in the phase shifting circuits are so chosen as to maintain a substantially 90° phase shift between 500 cycles and 15,000 cycles per second. Above and below these values, the phase shift becomes progressively less as the frequency moves away from these values. When the two signals 90° out of phase are controlled or modulated in the mixer by the output of the low frequency oscillator as shortly will be described, the modulation is uniform over the band between 500 cycles and 15,000 cycles. The percentage of phase shift thus is slightly less at higher frequencies within this band than at lower frequencies, but the difference in effect is relatively negligible. At the lowest frequencies, below 500 cycles, the percentage of phase swing (i.e. the percentage of modulation) must remain substantially constant to maintain a uniform tremulant effect.

The output of the low frequency oscillator 132 is converted into two signals 180° apart by the phase inverter 136, and these signals are applied to the grids of the mixer 32 as heretofore has been indicated, along with the musical oscillations which are 90° apart. The biasing of the mixers and the magnitude of the oscillations of the low frequency oscillator are such that each half of the tube 32 is first conducting with relatively high amplification, and then is cut down to relatively low amplification. The two halves of the tube operate 180° apart so that first the output of one of the tube halves is emphasized, and then the other. The result is that the combined output of the mixer shifts back and forth between the 90° out of phase musical signals to effect a phase shift vibrato or tremulant. The degree of phase shift is determined by the position of a movable switch contact of the speed and depth controls 134. When the greatest depth of vibrato is applied, each of the tube halves of the mixer 32 is alternately highly conductive and substantially cut off. This effects a maximum phase swing and a substantial tremulant. When the tremulant is applied with lesser depth, the relative conductivities of the two tube halves are not changed to such a great extent. Accordingly, the combined output does not swing as far, and the vibrato or tremulant is lessened.

It will be appreciated that in case it is decided to operate the treble tones without the tremulant, the low frequency oscillator can be turned off and the phase inverter can be utilized to bias the mixer tube 32 so that only one half thereof will be conducting, or the two

halves can be uniformly biased to provide a reverberation.

The 90° difference in the two output signals of the mixer 32 are represented at B and at A in Fig. 3. These signals then are applied to the phase inverter 34, the phase shifting networks 36 and 38, and the mixer 40 to produce a further 90° phase shift as may be seen at 36 and 38 in Fig. 3, the output of the mixer 40 being illustrated at B, BA, and A. This output then is applied to the phase inverter 42, the phase shifting networks 44 and 46, and the mixer 48 to produce a further 90° phase shift, thus giving the overall 270° phase shift as indicated at 48 in Fig. 3, there being a 90° shift between each of the signals B, BBA, BAA, and A. Further stages of phase shifting and mixing can be added if desired to produce a phase shift of substantially any degree to produce tremulant effects, or even effects not customarily produced by conventional organs.

The specific structure herein shown and described is by way of example only. Various modifications can be made in the structure, and are to be considered as forming a part of my invention insofar as they fall within the spirit and scope of the appended claims.

The invention is claimed as follows:

1. An electronic organ tremulant comprising a tone generator, an electronic valve device and a pair of resistance-capacitance networks connected thereto for splitting the tones generated thereby into a plurality of signals differing in phase, electronic means connected to said valve and said networks for combining the plurality of signals produced and including electronic means for relatively emphasizing one phase and then the other at a tremulant frequency to produce a tremulant effect, means connected to said combining means for splitting the combined tones into a plurality of signals differing in phase, and electronic means connected to said last-named splitting means for combining the last mentioned split tones and including means for relatively emphasizing one phase and then the other at a tremulant frequency to produce a tremulant effect.

2. An electronic organ circuit comprising a treble tone generator, a bass tone generator, means connected to said bass tone generator for producing a vibrato in the tones generated by said bass tone generator, means connected to the treble tone generator for splitting the tones generated by the treble tone generator into a plurality of signals differing in phase, electronic means connected to said splitting means for combining the plurality of signals produced and including electronic means for relatively emphasizing one phase and then the other at a tremulant frequency to produce a tremulant effect in the treble tones, and a common output circuit for the tremulant treble tones and the vibrato bass tones.

3. An electronic organ tremulant circuit as set forth in claim 2 wherein the vibrato means comprises a reactance tube connected to and shunting the bass tone generator.

4. An electronic organ circuit comprising a bass tone generator, a reactance tube connected to and shunting said bass tone generator for producing a vibrato in the bass tones, a treble tone generator, a series of tremulant producing devices serially connected to said treble tone generator and to one another for sequentially acting on the tones produced by said treble tone generator to produce a tremulant effect in the treble tones, and a common output circuit for the bass vibrato tones and the tremulant treble tones, each of said tremulant devices comprising means for splitting the tones generated by the treble tone generator into a plurality of signals differing in phase, and electronic means connected to said splitting means for combining the plurality of signals produced and including electronic means for relatively emphasizing one phase and then the other at a tremulant frequency to produce a tremulant effect.

5. An electronic organ circuit comprising a bass tone generator, means connected to said bass tone gener-

7

ator for producing a vibrato in the tones produced by said bass tone generator, a treble tone generator, a series of tremulant producing devices serially connected to said treble tone generator and to one another for sequentially acting on the tones produced by said treble tone generator, each of said devices comprising means for splitting the tones generated by said treble tone generator into a plurality of signals differing in phase, and electronic means connected to said splitting means for combining the plurality of signals produced and including electronic means for relatively emphasizing one phase and then the other at a tremulant frequency to produce a tremulant effect, and common output means for the bass tones and the treble tones.

6. An electronic organ circuit comprising a bass tone generator, bass vibrato means connected to said bass tone generator for producing a vibrato in the tones generated by said bass tone generator, a tremulant oscillator connected to and controlling said bass vibrato means, a treble tone generator, a series of tremulant producing de-

8  
vices serially connected to said treble tone generator and to one another for sequentially acting on the tones produced by said treble tone generator, each of said devices comprising means for splitting the tones generated by the treble tone generator into a plurality of signals differing in phase, electronic means connected to said splitting means for combining the plurality of signals produced and including electronic means controlled by said tremulant oscillator for relatively emphasizing one phase and then the other at a tremulant frequency to produce a tremulant effect, and a common output circuit for the bass tones and treble tones.

## References Cited in the file of this patent

## UNITED STATES PATENTS

2,316,155	Crosby	Apr. 13, 1943
2,373,560	Hanert	Apr. 10, 1945
2,509,923	Hanert	May 30, 1950
2,510,144	Schreifer	June 6, 1950