



US00RE43673E

(19) **United States**  
(12) **Reissued Patent**  
**Hou et al.**

(10) **Patent Number:** **US RE43,673 E**  
(45) **Date of Reissued Patent:** **Sep. 18, 2012**

(54) **DUAL GATE DIELECTRIC SCHEME: SION FOR HIGH PERFORMANCE DEVICES AND HIGH K FOR LOW POWER DEVICES**

(75) Inventors: **Tou-Hung Hou**, Chiayi (TW);  
**Ming-Fang Wang**, Taichung (TW);  
**Chi-Chun Chen**, Kaohsiung (TW);  
**Chih-Wei Yang**, Sinshih Township (TW);  
**Liang-Gi Yao**, Hsin-Chu (TW);  
**Shih-Chang Chen**, Hsin-Chu (TW)

(73) Assignee: **Taiwan Semiconductor Manufacturing Company, Ltd.**, Hsin-Chu (TW)

(21) Appl. No.: **11/518,593**

(22) Filed: **Sep. 8, 2006**

**Related U.S. Patent Documents**

Reissue of:

(64) Patent No.: **6,890,811**  
Issued: **May 10, 2005**  
Appl. No.: **10/679,768**  
Filed: **Oct. 6, 2003**

U.S. Applications:

(63) Continuation of application No. 10/282,387, filed on Oct. 29, 2002, now Pat. No. 6,706,581.

(51) **Int. Cl.**  
**H01L 21/8238** (2006.01)  
**H01L 29/76** (2006.01)

(52) **U.S. Cl.** ..... **438/216; 438/240; 438/287; 257/310; 257/410**

(58) **Field of Classification Search** ..... **257/310, 257/410, 411; 438/197, 199, 216, 240, 287**  
See application file for complete search history.

(56) **References Cited**

U.S. PATENT DOCUMENTS

5,960,289	A	9/1999	Tsui et al.	438/275
6,048,769	A *	4/2000	Chau	438/275
6,087,236	A *	7/2000	Chau et al.	438/301
6,144,063	A *	11/2000	Yeap et al.	257/321
6,159,782	A	12/2000	Xiang et al.	438/197
6,211,034	B1 *	4/2001	Visokay et al.	257/E21.011
6,248,675	B1	6/2001	Xiang et al.	438/926
6,265,325	B1	7/2001	Cao et al.	438/763
6,309,936	B1 *	10/2001	Gardner et al.	438/305
6,362,059	B2 *	3/2002	Fukasaku et al.	438/289
6,406,956	B1 *	6/2002	Tsai et al.	438/201
6,420,742	B1 *	7/2002	Ahn et al.	257/295

(Continued)

OTHER PUBLICATIONS

Article "Outlook on New Transistor Materials," by L. Peters in Semiconductor International, Oct. 1, 2001 edition.

*Primary Examiner* — Kevin M Picardat

(74) *Attorney, Agent, or Firm* — Slater & Matsil, L.L.P.

(57) **ABSTRACT**

A method of forming dual gate dielectric layers that is extendable to satisfying requirements for 50 nm and 70 nm technology nodes is described. A substrate is provided with STI regions that separate device areas. An interfacial layer and a high k dielectric layer are sequentially deposited on the substrate. The two layers are removed over one device area and an ultra thin silicon oxynitride layer with an EOT<10 nm is grown on the exposed device area. The high k dielectric layer is annealed during growth of the SiON dielectric layer. The high k dielectric layer is formed from a metal oxide or its silicate or aluminate and enables a low power device to be fabricated with an EOT<1.8 nm with a suppressed leakage current. The method is compatible with a dual or triple oxide thickness process when forming multiple gates.

**32 Claims, 5 Drawing Sheets**

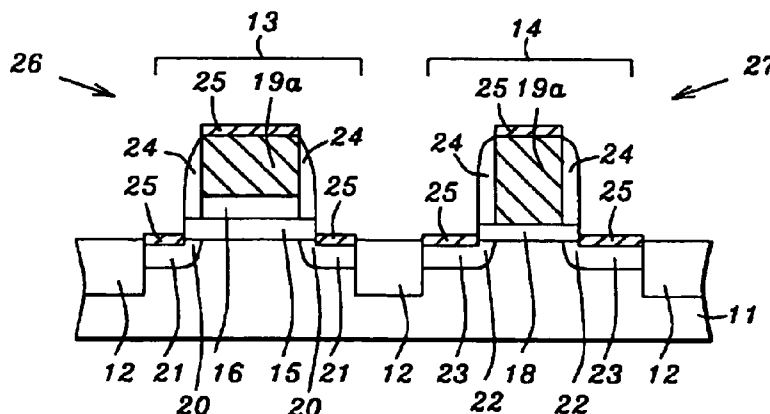

# US RE43,673 E

Page 2

---

## U.S. PATENT DOCUMENTS

6,436,749	B1 *	8/2002	Tonti et al. ....	438/199	6,597,046	B1 *	7/2003	Chau et al. ....	257/411
6,455,330	B1 *	9/2002	Yao et al. ....	438/3	6,638,877	B2 *	10/2003	Rotondaro ....	438/770
6,468,851	B1 *	10/2002	Ang et al. ....	438/216	6,713,353	B1 *	3/2004	Kanda et al. ....	438/275
6,482,726	B1 *	11/2002	Aminpur et al. ....	257/E21.206	6,727,130	B2 *	4/2004	Kim et al. ....	438/199
6,495,422	B1 *	12/2002	Yu et al. ....	438/275	6,730,566	B2 *	5/2004	Niimi et al. ....	438/275
6,524,910	B1 *	2/2003	Lin et al. ....	438/257	6,759,302	B1 *	7/2004	Chen et al. ....	438/275
6,528,858	B1 *	3/2003	Yu et al. ....	257/493	2006/0091469	A1 *	5/2006	Ho et al. ....	257/368

\* cited by examiner

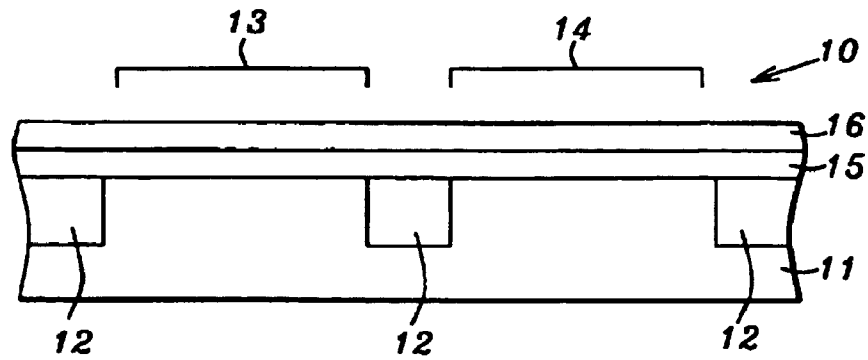

FIG. 1a

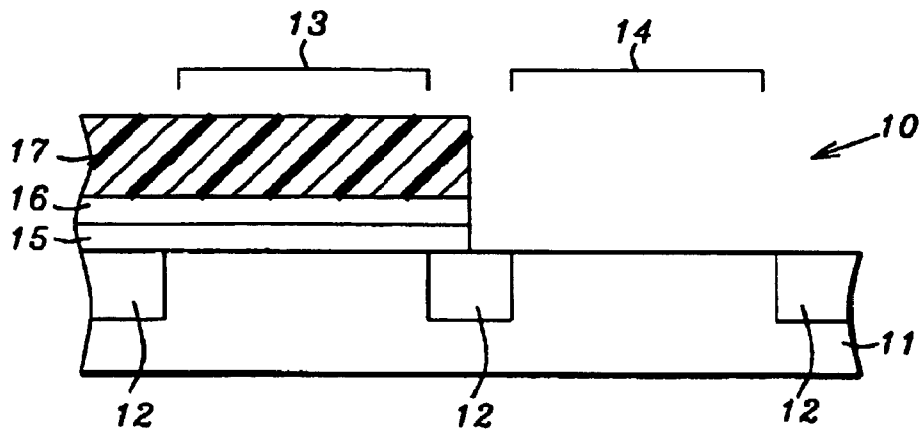

FIG. 1b

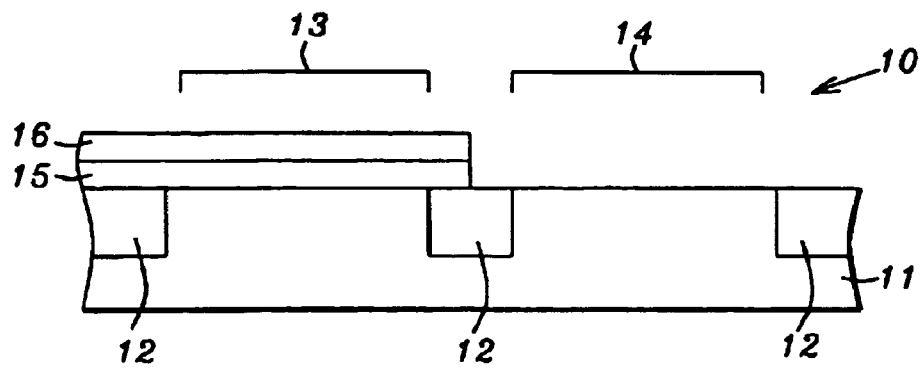

FIG. 1c

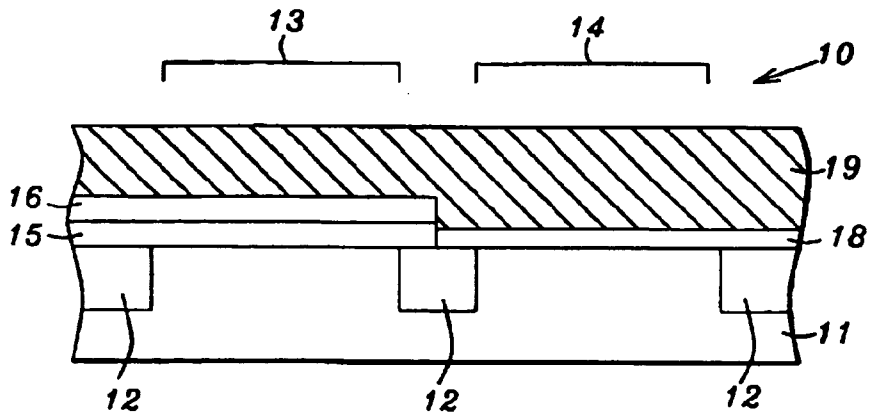

FIG. 1d

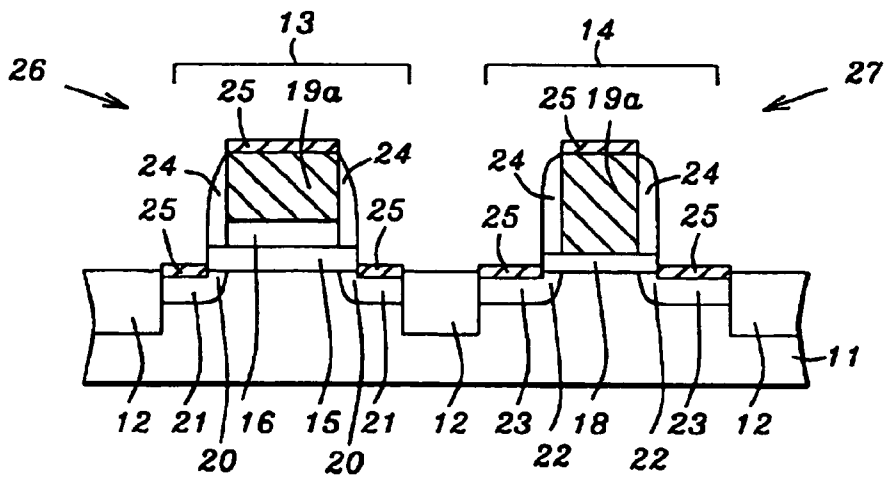

FIG. 1e

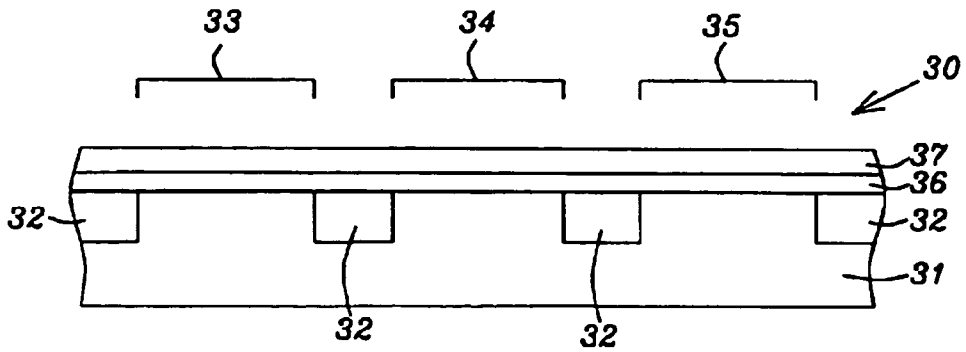

FIG. 2a

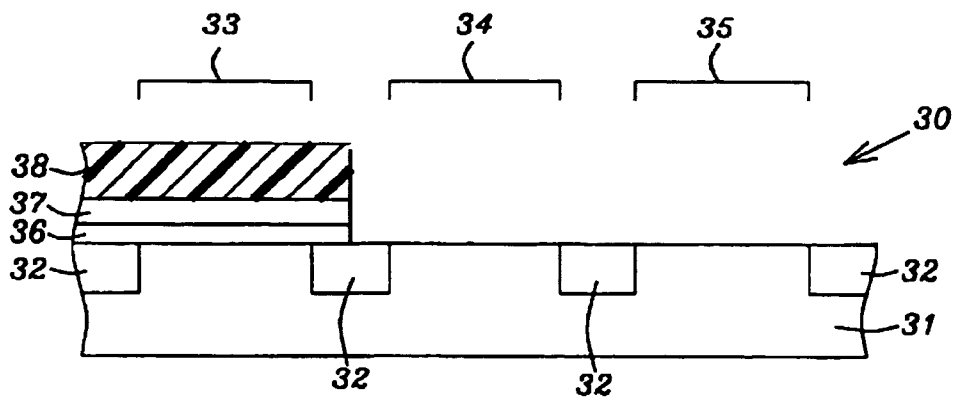

FIG. 2b

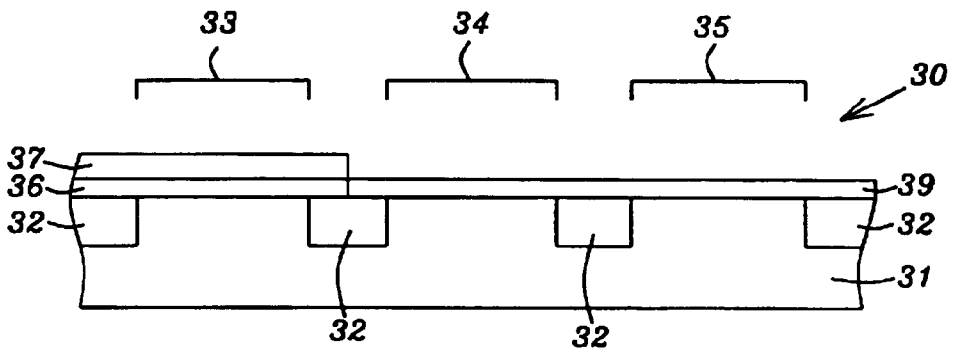

FIG. 2c

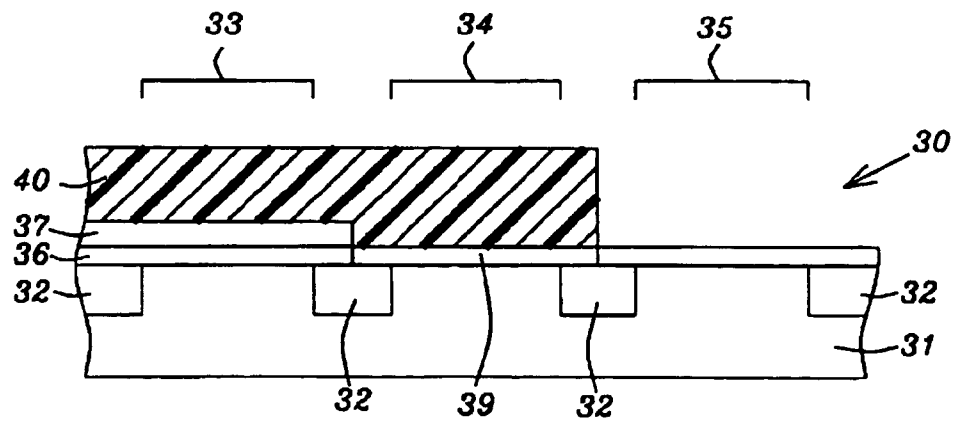

FIG. 2d

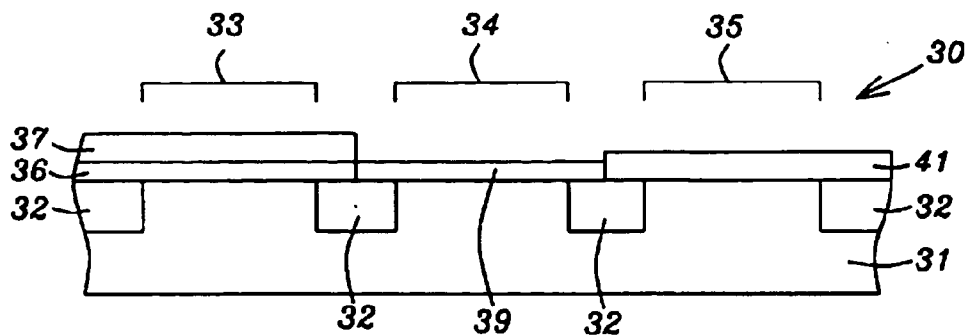

FIG. 2e

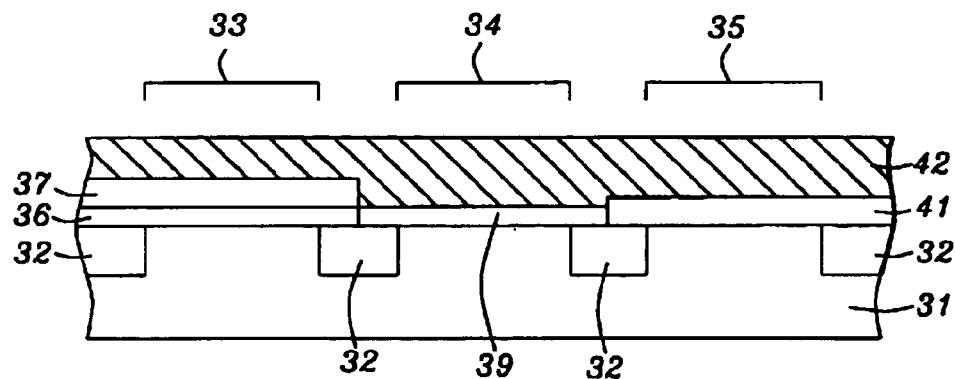

FIG. 2f

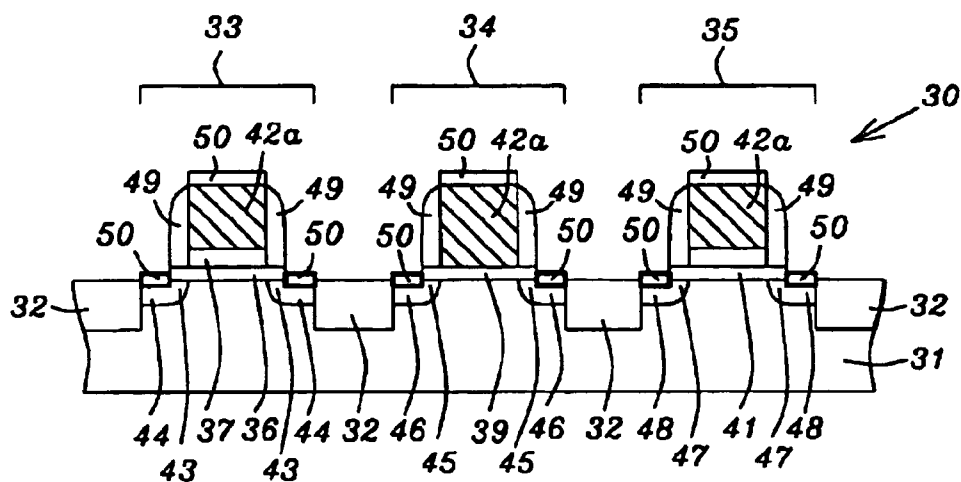

FIG. 2g

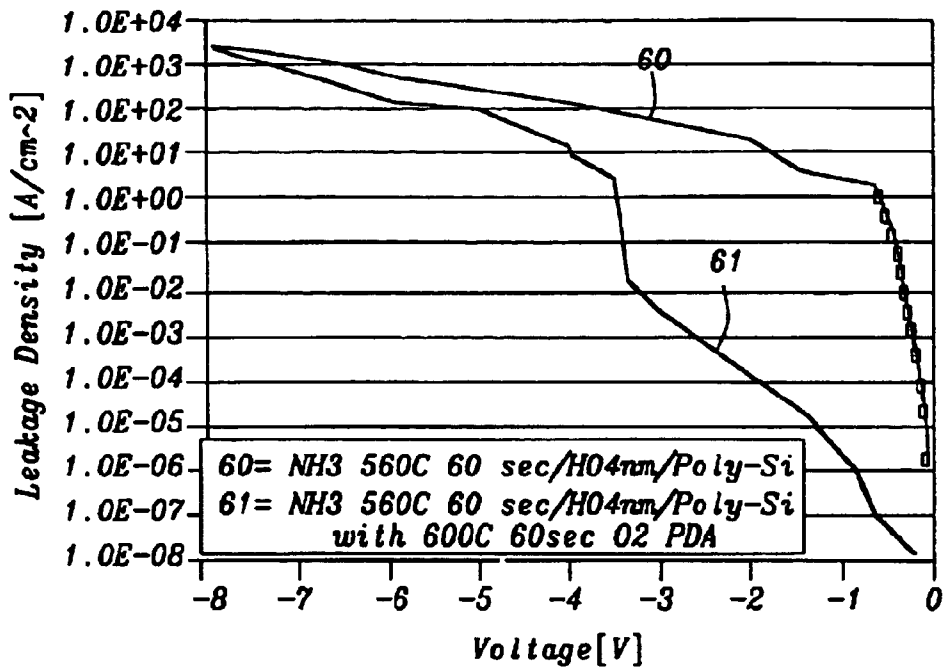

FIG. 3

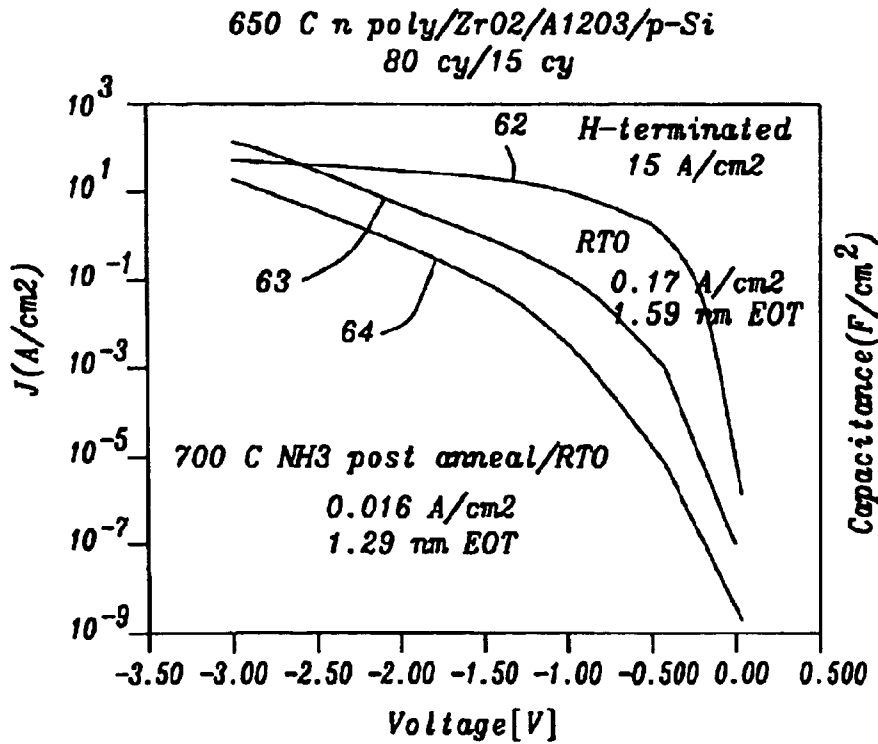

FIG. 4

**DUAL GATE DIELECTRIC SCHEME: SION  
FOR HIGH PERFORMANCE DEVICES AND  
HIGH K FOR LOW POWER DEVICES**

**Matter enclosed in heavy brackets [ ] appears in the original patent but forms no part of this reissue specification; matter printed in italics indicates the additions made by reissue.**

This application is a continuation of U.S. Ser. No. 10/282,387, filed Oct. 29, 2002 now U.S. Pat No. 6,706,581.

FIELD OF THE INVENTION

The present invention relates to a method of semiconductor manufacturing. In particular, the method involves forming two or more gate dielectric layers comprised of different materials during the fabrication of integrated circuits for system on a chip (SOC) technology.

BACKGROUND OF THE INVENTION

Complimentary metal oxide semiconductor (CMOS) field effect transistor (FET) technology is being driven to smaller gate electrode sizes by a constant demand for higher performance. As stated in an article "Outlook on New Transistor Materials" by L. Peters in Semiconductor International, Oct. 1, 2001 edition, the next generation 70 nm and 50 nm technology nodes will need new gate dielectric materials in order to accommodate a shrinking gate size. A high k dielectric option comprised of a metal oxide is a leading candidate to replace the traditional oxide or oxynitride layer. A higher k value in materials such as Ta<sub>2</sub>O<sub>5</sub>, TiO<sub>2</sub>, Al<sub>2</sub>O<sub>3</sub>, ZrO<sub>2</sub>, HfO<sub>2</sub>, Y<sub>2</sub>O<sub>3</sub>, L<sub>2</sub>O<sub>5</sub> and their aluminates and silicates will enable an increase in the physical dielectric thickness to suppress tunneling current which causes a high gate leakage current in transistors. The high k dielectric material can be formed as an amorphous layer or as a monocrystalline layer. The interfacial layer for the gate dielectric includes oxides, nitrides, oxynitrides, and aluminates. In some cases an interfacial layer is omitted and the gate dielectric material is formed directly on silicon.

The thickness of the gate oxide is critical to the performance of the device. There is a constant need for thinner oxides to allow a higher speed device with lower power consumption. Current technology requires gate oxide thicknesses of about 50 Angstroms or less. For ultra thin silicon dioxide gates, leakage current will increase tremendously as thickness is reduced. This will cause a large current in the standby mode (*I<sub>OFF</sub>*) and a large standby power consumption, thereby making products with these devices commercially unacceptable. Thus, new gate dielectric materials are required to suppress gate leakage as the gate dielectric thickness approaches 20 nm or less.

With the introduction of system on a chip (SOC) technology, there is a need to form multiple gate dielectric thicknesses on a substrate to enable different functions to perform simultaneously. For example, circuits for I/O connections, high performance devices, and low power devices must be fabricated on the same substrate. While low power circuits currently require an effective gate oxide thickness (EOT) of 12 to 15 Angstroms and high performance circuits need an EOT in the range of 8 to 12 Angstroms, the IC industry predicts the driver for high k dielectrics will be the low power application with an estimated EOT=1.8 nm in 2005. Silicon

oxynitride (SiON) can function adequately as the gate dielectric for high performance devices until 2005, but for low power devices the switch to high k dielectrics must occur for an EOT<17 Angstroms in order to satisfy the leakage requirements.

A method for forming dual gate oxide layers having different thicknesses is described in U.S. Pat. No. 6,265,325 in which a field oxide separates two device areas. After a thermal oxide layer is grown and a polysilicon layer is deposited, a photoresist mask is used to selectively uncover the substrate in one device area. A second oxide layer is grown that is thinner than the first oxide. Then a second polysilicon layer is formed over both device areas. A planarization step is employed to make the second polysilicon layer coplanar with the first polysilicon layer.

Another method for fabricating a dual oxide gate structure is provided in U.S. Pat. No. 5,960,289. An oxide in the range of 50 to 240 Angstroms thick is grown between shallow trench isolation (STI) regions and is protected by subsequently depositing a thin silicon oxynitride (SiON) layer. A photoresist layer is coated and patterned and serves as an etch mask for selectively removing the SiO<sub>2</sub> and SiON over one device region. A thin oxide which is 20 to 60 Angstroms thick is then grown over the exposed device region while SiON prevents any additional oxide growth on the other device region. This prior art and the previous case do not address extendibility to gate dielectric thicknesses less than 20 Angstroms where high k dielectric materials will be needed.

Related U.S. Pat. Nos. 6,159,782 and 6,248,675 introduce a high k dielectric approach for manufacturing an N-channel MOSFET and a P-channel MOSFET on the same substrate. High temperature processes such as activation anneal of implanted ions and silicidation anneal are performed on a dummy gate electrode and sacrificial gate dielectric so as to preserve the integrity of a Ta<sub>2</sub>O<sub>5</sub> high k dielectric that is deposited later and is sensitive to temperatures over 800° C. Once the dummy gate electrode is removed by etching to form a gate opening, a conformal layer of SiON is deposited followed by a conformal layer of Ta<sub>2</sub>O<sub>5</sub>. The opening is filled with amorphous silicon, planarized, and is then annealed at <600° C. to produce a permanent gate electrode. However, the method does not teach how to form a dielectric layer for a high performance device and a high k dielectric layer for a low power device on the same substrate for a SOC application.

Therefore, a method is needed whereby a gate dielectric layer with an EOT of less than 10 nm for a high performance device and a high k dielectric layer with an EOT preferably <10 nm for a low power device can be formed on the same substrate for current and future SOC applications.

SUMMARY OF THE INVENTION

An objective of the present invention is to provide a method of forming a SiON dielectric layer and a high k dielectric layer on the same substrate during the fabrication of a semiconductor device, micro-electromechanical (MEMS) device, or other device requiring the formation of a gate electrode on a substrate.

A further objective of the present invention is to provide a method of forming a high k dielectric layer that is scalable to the 70 nm and 50 nm technology nodes, preferably with an EOT that is <1.8 nm for a low power device.

A still further objective of the present invention is to provide a dual gate dielectric scheme that is compatible with a conventional dual or triple thickness SiO<sub>2</sub> process.

A still further objective is to provide an efficient, low cost dual gate dielectric process in which the high k dielectric layer can be annealed simultaneously with the growth of the second dielectric layer.

These objectives are achieved by first providing a substrate with device areas separated by regions of insulating material such as STI features. In the first embodiment, an interfacial layer comprised of SiO<sub>2</sub>, SiON, or Si<sub>3</sub>N<sub>4</sub> is deposited on the substrate. A high k dielectric material is then deposited by a chemical vapor deposition (CVD), metal-organic CVD (MOCVD), or atomic layer CVD (ALD) process. The high k dielectric material is selected from a group of metal oxides including Ta<sub>2</sub>O<sub>5</sub>, TiO<sub>2</sub>, Al<sub>2</sub>O<sub>3</sub>, ZrO<sub>2</sub>, HfO<sub>2</sub>, Y<sub>2</sub>O<sub>3</sub>, L<sub>2</sub>O<sub>3</sub> and their aluminates and silicates. The high k dielectric material may comprise a single layer of one metal oxide or several layers including two or more metal oxides. A photoresist is coated and patterned on the high k dielectric layer to uncover the substrate in a region that will form the high performance device. After the high k dielectric and interfacial layers are removed in exposed regions, the photoresist is stripped and the substrate is cleaned. An ultra thin SiON layer with an EOT of preferably <10 nm is then deposited by using a silicon source gas in combination with NH<sub>3</sub>, NO or N<sub>2</sub> with O<sub>2</sub>. During the deposition of the second dielectric layer, the high k dielectric layer is annealed in an in-situ process. A post-deposition anneal involving NH<sub>3</sub> or a nitrogen containing gas may be added to further reduce leakage current and lower EOT. Conventional processing is followed to complete the construction of a MOSFET that is a low power device from the region containing the high k dielectric layer and a MOSFET that is a high performance device from the region containing the SiON dielectric layer.

In a second embodiment, a substrate is provided in which STI regions separate device areas that will become a low power device, a high performance device, and an I/O device. An interfacial layer comprised of SiON, Si<sub>3</sub>N<sub>4</sub> or SiO<sub>2</sub> is deposited on the substrate. A high k dielectric material is then deposited by a CVD, MOCVD, or ALD process. The high k dielectric material is selected from a group metal oxides and their aluminates and silicates described in the first embodiment. The high k dielectric material may comprise a single layer of one metal oxide or several layers including two or more metal oxides. A photoresist is coated and patterned on the high k dielectric layer to uncover the substrate in a region that will form the high performance device and which will form the I/O device. After the high k dielectric and interfacial layers are removed from exposed regions, the photoresist is stripped and the substrate is cleaned. An ultra thin SiON layer with an EOT of preferably <10 nm is then deposited by using a silicon source gas in combination with NH<sub>3</sub>, NO or N<sub>2</sub> with O<sub>2</sub>. During the deposition of the second dielectric layer that will become part of the high performance device, the high k dielectric layer is annealed. A second photoresist is then coated and patterned to expose the high k dielectric layer above the I/O device area. An etch selectively removes the SiON layer over the third device area. After a photoresist strip and a cleaning step, an oxide layer is grown on the third device area to form a gate dielectric layer with a thickness that is consistent with an I/O device.

#### BRIEF DESCRIPTION OF THE DRAWINGS

The drawings illustrate embodiments of the invention and together with the description serve to explain the principles of the present invention.

FIG. 1a is a cross sectional view of a structure having two device areas separated by STI regions and upon which an interfacial layer and a high k dielectric layer have been formed.

FIG. 1b is a cross sectional view of the two device areas in FIG. 1a after a patterned photoresist was used as an etch mask for the removal of the layers above one device area.

FIG. 1c is a cross sectional view of the two device areas in FIG. 1b with the photoresist removed and a second dielectric layer formed on the second device area.

FIG. 1d is a cross sectional view of the two device areas in FIG. 1c after a polysilicon layer is deposited on the substrate.

FIG. 1e is a cross sectional view after MOSFETs for a low power device and a high performance device have been fabricated on the same substrate.

FIG. 2a is a cross sectional view of a structure having three device areas separated by STI structures on a substrate.

FIG. 2b is a cross sectional view of the three device areas in FIG. 2a after a patterned photoresist was used as an etch mask for the removal of the layers above two device areas.

FIG. 2c is a cross sectional view of the three device areas in FIG. 2b with the photoresist removed and a second dielectric layer formed on two device areas.

FIG. 2d is a cross sectional view of the three device areas in FIG. 2c after a patterned photoresist was used as an etch mask for the removal of the second dielectric layer above the third device area.

FIG. 2e is a cross sectional view of the three device areas in FIG. 2d with the photoresist removed and a third dielectric layer formed on the third device area.

FIG. 2f is a cross sectional view of the three device areas in FIG. 2e after a polysilicon layer is deposited on the substrate.

FIG. 2g is a cross sectional view after MOSFETs for a low power device, a high performance device and an I/O device are formed on the same substrate.

FIG. 3 is a plot of voltage vs. leakage density showing a reduction in leakage current following an oxygen anneal of a HfO<sub>2</sub> high k dielectric layer.

FIG. 4 is a plot of voltage vs. leakage current showing a reduction in leakage current when an NH<sub>3</sub> anneal follows an oxygen anneal of a high k dielectric layer comprised of ZrO<sub>2</sub> and Al<sub>2</sub>O<sub>3</sub>.

#### DETAILED DESCRIPTION OF THE INVENTION

The present invention provides a method for forming a high k dielectric layer and an SiON dielectric layer on the same substrate. In the first embodiment, the high k dielectric layer is incorporated into a low power device and the SiON dielectric layer is incorporated into a high performance device.

While the drawings in FIGS. 1a-1e are intended to give a description of the first embodiment, the scope of the present invention is not limited by the drawings. For example, the FIGS. 1a-1e are not necessarily drawn to scale. In addition, the substrate is simplified in the drawings and a substructure containing other devices and sub-layers is not shown. Referring to FIG. 1a, a structure **10** is shown which consists of a substrate **11** and shallow trench isolation regions **12** that separate device areas **13** and **14**. A MOSFET which is a low power device will be fabricated on device area **13** and a MOSFET which is a high performance device will be fabricated on device area **14**. The substrate **11** is preferably silicon but may be made of gallium arsenide, silicon-germanium, or silicon-on-insulator (SOI) substrates. Furthermore, the substrate **11** may contain dopants that are either n-type or p-type

dopants. STI regions **12** contain an insulating material such as silicon dioxide and are formed by a conventional method that is not described herein.

An interfacial layer **15** is deposited on substrate **11** to a thickness between 0 and 30 Angstroms and consists of a material such as SiO<sub>2</sub>, SiON, or silicon nitride. The interfacial layer **15** is preferably formed by a rapid thermal process (RTP) in a temperature range of about 500° C. to 1000° C. although a plasma enhanced CVD or a low pressure CVD can also be used for the deposition. When the layer is SiON, the RTP preferably involves a silane or silicon containing gas as well as NH<sub>3</sub>. Optionally, the RTP may include N<sub>2</sub>O, O<sub>2</sub> or NO in combination with NH<sub>3</sub>, or N<sub>2</sub> and O<sub>2</sub> instead of NH<sub>3</sub>.

A high k dielectric stack **16** is then formed on the interfacial layer **15** by a CVD, MOCVD, or ALD process. The interfacial layer may not be required in some cases but generally an interfacial layer **15** is preferred in order to enable a smooth interface between the substrate **11** and the high k dielectric stack **16**. A pre-gate cleaning step which is suitable for high-k deposition can be inserted before the high k dielectric stack **16** deposition. Such a cleaning step typically involves a hydrophilic or hydrophobic technique that is well known to those skilled in the art. The high k dielectric stack **16** may consist of a single layer or may be two or more layers comprising one or more materials selected from the group including Ta<sub>2</sub>O<sub>5</sub>, TiO<sub>2</sub>, Al<sub>2</sub>O<sub>3</sub>, ZrO<sub>2</sub>, HfO<sub>2</sub>, Y<sub>2</sub>O<sub>3</sub>, L<sub>2</sub>O<sub>3</sub> and their aluminates and silicates. A preferred thickness of the high k dielectric stack **16** is from about 15 to 100 Angstroms.

Referring to FIG. 1b, a photoresist **17** is coated on the high k dielectric stack **16** and patterned such that regions of photoresist **17** are washed away above device area **14** and remain on device area **13**. A wet etch or plasma etch is then performed to selectively remove layers **15** and **16** that have been exposed by the opening in photoresist **17**. Some metal oxides such as HfO<sub>2</sub> are very resistant to HF and wet etchants like H<sub>2</sub>SO<sub>4</sub>/H<sub>2</sub>O<sub>2</sub> (SPM). Therefore, a plasma etch may be preferred for removal of the high k dielectric stack **16**. If the high k dielectric layer is a silicate of a metal oxide such as Hf<sub>x</sub>Si<sub>y</sub>O<sub>z</sub>, then a buffered HF etch may be preferred for removing high k dielectric stack **16**. A wet etch with a buffered HF solution is normally used to remove silicon oxynitride layer **15**.

Referring to FIG. 1c, the photoresist **17** is stripped by an oxygen ashing method or by immersing the structure **10** in a liquid stripper. The structure **10** is then typically cleaned by immersing sequentially in NH<sub>4</sub>OH/H<sub>2</sub>O<sub>2</sub> (SC-1) and HCl/H<sub>2</sub>O<sub>2</sub> (SC-2) cleaning solutions that are part of the standard RCA cleaning process followed by DI water rinsing and drying.

An ultra thin dielectric layer **18** is then grown on device area **14** and during the process the high k dielectric stack **16** is annealed. When dielectric layer **18** is silicon oxynitride, layer **18** preferably has an EOT < 10 nm. Layer **18** also covers STI regions **12** that are exposed after removal of interfacial layer **15** and high k dielectric stack **16**. The annealing is a rapid thermal process and is performed in a temperature range of about 500° C. to 1000° C. for about 10 to 500 seconds and may include O<sub>2</sub>, N<sub>2</sub>, NO, NH<sub>3</sub>, or any combination of the aforementioned gases. When only an oxygen ambient is employed, a dielectric layer **18** comprised of SiO<sub>2</sub> is formed instead of SiON. The annealing improves the quality of the high k dielectric material and lowers the leakage current in the MOSFET that is formed from the dielectric stack **16**.

For example, when the high k dielectric stack **16** is a layer of HfO<sub>2</sub> that is deposited on an SiON interfacial layer that has been formed under conditions including ammonia at 560° C., the top curve **60** in the plot depicted in FIG. 3 shows the leakage current associated with a particular applied voltage in

a device fabricated from this stack. A significant improvement is noted when the HfO<sub>2</sub> layer **16** is annealed in an O<sub>2</sub> ambient at 600° C. for 60 seconds. The lower curve **61** in FIG. 3 indicates that the post-deposition anneal with O<sub>2</sub> reduces the leakage current significantly, especially for a normal operating voltage of about 2 V.

When the high k dielectric stack **16** is comprised of ZrO<sub>2</sub> and Al<sub>2</sub>O<sub>3</sub> layers, then an anneal with NH<sub>3</sub> is especially effective in reducing the leakage current as illustrated in FIG. 4. The top curve **62** in the plot depicted in FIG. 4 shows the leakage current vs. voltage in a device fabricated from a high k dielectric stack with ZrO<sub>2</sub>/Al<sub>2</sub>O<sub>3</sub> which has no interfacial layer **15**. The middle curve **63** indicates a lower leakage current of ZrO<sub>2</sub>/Al<sub>2</sub>O<sub>3</sub> grown on a rapid thermal oxidation (RTO) surface. The lower curve **64** in FIG. 4 shows the leakage current is further reduced after a post deposition anneal with NH<sub>3</sub> at 700° C. Note that the EOT also decreases from 1.59 nm to 1.29 nm following the NH<sub>3</sub> anneal.

Referring to FIG. 1d, a conductive layer **19** is deposited on device areas **13** and **14**. Preferably, the conductive layer **19** is polysilicon that may be doped with boron, arsenic, phosphorus, or other useful dopant atoms. Layer **19** can also be comprised of other known gate electrode materials such as amorphous silicon.

Referring to FIG. 1e, a MOSFET is fabricated in device areas **13** and **14** from the structure **10** shown in FIG. 1d. A photoresist (not shown) is patterned and serves as an etch mask for etching the gate electrode pattern through layer **19** to form gate electrodes **19a** in device regions **13** and **14**. Then gate dielectric stack **16**, gate dielectric layer **18**, and interfacial layer **15** are etched in a self-aligned manner. Typically, an ion implant is performed to form lightly doped regions **20**, **22** in substrate **11** adjacent to gate electrodes **19a**. Conventional processing is followed to introduce nitride spacers **24** on the sides of the electrodes **19a** and to form heavily doped source/drain (S/D) regions **21**, **23** in the substrate **11**. Silicide regions **25** are formed on gate electrodes **19a** and above heavily doped S/D regions **21**, **23**. Contacts (not shown) can then be made to silicide regions **25** from an overlying conductive layer in subsequent processing. The result is that structure **10** comprises a MOSFET **26** that is a lower power device and a MOSFET **27** which is a high performance device.

The advantage of the first embodiment over prior art is that MOSFET **26** contains a high k dielectric layer **16** that enables the low power device to meet future requirements of < 1.8 nm EOT. Gate leakage current has been suppressed to an acceptable level. Furthermore, on the same substrate, a MOSFET **27** has been fabricated which contains a SiON gate dielectric layer that is extendable to < 1 nm EOT to satisfy future requirements for 50 and 70 nm technology nodes. The method can be readily implemented in a manufacturing scheme at a minimal cost, especially when the high k dielectric anneal step is performed in-situ with the silicon oxynitride deposition of the second gate dielectric layer.

In a second embodiment, a method is provided for forming three distinct devices on the same substrate. A high k dielectric layer is incorporated in a low power device, and silicon oxynitride or SiO<sub>2</sub> layers are incorporated in high performance and I/O devices. While the drawings in FIGS. 2a-2g are intended to give a description of the second embodiment, the scope of the present invention is not limited by the drawings. For example, the FIGS. 2a-2g are not necessarily drawn to scale. In addition, the substrate is simplified in the drawings and a substructure containing other devices and sub-layers is not shown.

Referring to FIG. 2a, a structure **30** is shown which consists of a substrate **31** and shallow trench isolation regions **32** that

separate device areas **33**, **34** and **35**. A low power device will be fabricated on device area **33** while a high performance device and an I/O device will be fabricated on device areas **34** and **35**, respectively. The substrate **31** is preferably silicon but may be made of gallium arsenide, silicon-germanium, or silicon-on-insulator (SOI) substrates. Furthermore, the substrate **31** may contain dopants that are either n-type or p-type dopants. STI regions **32** contain an insulating material such as silicon dioxide and are formed by a conventional method that is not described to herein.

An interfacial layer **36** is deposited on substrate **31** to a thickness between about 0 and 15 Angstroms and consists of a material such as SiO<sub>2</sub>, SiON, or silicon nitride. The interfacial layer **36** is preferably formed by a rapid thermal process (RTP) in a temperature range of between 500° C. and 1000° C. although a plasma enhanced CVD or a low pressure CVD can also be used for the deposition. When the layer **36** is silicon oxynitride, the RTP preferably involves a silane or silicon containing source gas as well as NH<sub>3</sub>. Optionally, the RTP may include N<sub>2</sub>O, O<sub>2</sub> or NO in combination with NH<sub>3</sub>, or N<sub>2</sub> and O<sub>2</sub> instead of NH<sub>3</sub>.

A high k dielectric stack **37** is then formed on the interfacial layer **36** by a CVD, MOCVD, or ALD process. The interfacial layer may not be required in some cases but generally an interfacial layer **36** is preferred in order to enable a smooth interface between the substrate **31** and the high k dielectric stack **37**. A pre-gate cleaning step which is suitable for high-k deposition can be inserted before the high k dielectric stack **37** deposition. Such a cleaning step typically involves a hydrophilic or hydrophobic technique that is well known to those skilled in the art. The high k dielectric stack **37** may consist of a single layer or may be two or more layers comprising one or more materials selected from the group including Ta<sub>2</sub>O<sub>5</sub>, TiO<sub>2</sub>, Al<sub>2</sub>O<sub>3</sub>, ZrO<sub>2</sub>, HfO<sub>2</sub>, Y<sub>2</sub>O<sub>3</sub>, L<sub>2</sub>O<sub>3</sub> and their aluminates and silicates. A preferred thickness of the high k dielectric stack **37** is from about 15 to 100 Angstroms.

Referring to FIG. 2b, a photoresist **38** is coated on the high k dielectric stack **37** and patterned such that regions of photoresist **38** are washed away by developer above device areas **34** and **35** and remain on device area **33**. A wet etch or plasma etch as described is then performed to selectively remove layers **36** and **37** that have been exposed by the opening in photoresist **38**. Some metal oxides such as HfO<sub>2</sub> are very resistant to HF and wet etchants like H<sub>2</sub>SO<sub>4</sub>/H<sub>2</sub>O<sub>2</sub> (SPM). Therefore, a plasma etch may be preferred for removal of the high k dielectric stack **37**. If the high k dielectric material is a silicate of a metal oxide such as Hf<sub>x</sub>Si<sub>y</sub>O<sub>z</sub>, then a buffered HF etch may be preferred for removing high k dielectric stack **37**. A wet etch involving a buffered HF solution is normally used to remove silicon oxynitride layer **36**.

Referring to FIG. 2c, the photoresist **38** is stripped by an oxygen ashing method or by immersing the structure **30** in a liquid stripper. The structure **30** is then typically cleaned by immersing sequentially in NH<sub>4</sub>OH/H<sub>2</sub>O<sub>2</sub> (SC-1) and HCl/H<sub>2</sub>O<sub>2</sub> (SC-2) cleaning solutions that are part of the standard RCA cleaning process followed by DI water rinsing and drying.

An ultra thin dielectric layer **39** is then grown on device areas **34**, **35** and during the process the high k dielectric stack **37** is annealed. When the dielectric layer **39** is silicon oxynitride, layer **39** preferably has an EOT < 10 nm. Layer **39** also covers STI regions **32** that are exposed after removal of interfacial layer **36** and high k dielectric stack **37**. The annealing is a rapid thermal process and is performed in a temperature range of about 500° C. to 1000° C. for about 10 to 500 seconds and may include O<sub>2</sub>, N<sub>2</sub>, NO, NH<sub>3</sub>, or any combination of the aforementioned gases. When only an oxygen ambient is

employed, a dielectric layer **39** comprised of SiO<sub>2</sub> is formed instead of SiON. The annealing improves the quality of the high k dielectric material and lowers the leakage current in the MOSFET that is formed from the dielectric stack **37**.

For example, when the high k dielectric stack **37** is a layer of HfO<sub>2</sub> that is deposited on a SiON interfacial layer that has been formed under conditions involving ammonia at 560° C., the top curve **60** in the plot depicted in FIG. 3 shows the leakage current associated with a particular applied voltage in a device fabricated from this stack. A significant improvement is noted when the HfO<sub>2</sub> layer **37** is annealed in an O<sub>2</sub> ambient at 600° C. for 60 seconds. The lower curve **61** in FIG. 3 indicates that the post-deposition anneal with O<sub>2</sub> reduces the leakage current significantly, especially for a normal operating voltage of about 2 V.

When the high k dielectric stack **37** is comprised of ZrO<sub>2</sub> and Al<sub>2</sub>O<sub>3</sub> layers, then an anneal with NH<sub>3</sub> is especially effective in reducing the leakage current as illustrated in FIG. 4. The top curve **62** in the plot depicted in FIG. 4 shows the leakage current vs. voltage in a device fabricated from a high k dielectric stack with ZrO<sub>2</sub>/Al<sub>2</sub>O<sub>3</sub> which has no interfacial layer **36**. The middle curve **63** indicates a lower leakage current of ZrO<sub>2</sub>/Al<sub>2</sub>O<sub>3</sub> grown on a rapid thermal oxidation (RTO) surface. The lower curve **64** in FIG. 4 shows the leakage current is further reduced after a post deposition anneal with NH<sub>3</sub> at 700° C. Note that the EOT also decreases from 1.59 nm to 1.29 nm following the NH<sub>3</sub> anneal.

Referring to FIG. 2d, a photoresist **40** is coated on the high k dielectric stack **37** and on dielectric layer **39** and is patterned such that regions of photoresist **40** are washed away by developer above device area **35** and remain on device areas **33** and **34**. A wet etch or plasma etch is then performed to selectively remove layer **39** in device area **35** that has been exposed by the opening in photoresist **40** which results in a structure **30**.

Referring to FIG. 2e, the photoresist **40** is stripped by an oxygen ashing method or by a liquid stripper and structure **30** is then cleaned as before with SC-1 and SC-2 solutions. Next a SiO<sub>2</sub> layer **41** is formed by a rapid thermal oxidation method with a thickness between about 10 and 100 Angstroms that is consistent with a dielectric layer for an I/O device in device area **35**. When dielectric layer is **39** is silicon oxynitride, layer **39** prevents any further oxidation of device area **34**. If dielectric layer **39** is SiO<sub>2</sub>, the thickness of layer **39** in device area **34** increases slightly during the SiO<sub>2</sub> growth in device area **35**.

FIG. 2f shows that a conductive layer **42** is deposited on device areas **33**, **34**, and **35**. Preferably, the conductive layer **42** is polysilicon that may be doped with boron, arsenic, phosphorus, or other useful dopants. Layer **42** can also be comprised of other known gate electrode materials such as amorphous silicon.

Referring to FIG. 2g, a MOSFET is fabricated in each of device areas **33**, **34** and **35**. A photoresist (not shown) is patterned and serves as an etch mask for etching the gate electrode pattern through layer **42** to form gate electrodes **42a** in device areas **33**, **34** and **35**. Then gate dielectric stack **37**, dielectric layers **39**, **41**, and interfacial layer **36** are etched in a self-aligned manner. Typically, an ion implant is performed to form lightly doped regions **43**, **45** and **47** in substrate **31** adjacent to gate electrodes **42a**. Conventional processing is followed to introduce nitride spacers **49** on the sides of the electrodes **42a** and on the sidewalls of layers **36**, **37**. An ion implant is generally employed to form heavily doped source/drain (S/D) regions **44**, **46**, **48** in the substrate **31**. Silicide regions **50** are formed on gate electrodes **42a** and above heavily doped S/D regions **44**, **46**, and **48**. Contacts (not shown) can then be made to silicide regions **50** from an overlying conductive layer in subsequent processing. The

result is that structure **30** comprises a MOSFET **33** that is a lower power device, a MOSFET **34** that is a high performance device, and a MOSFET **35** which is an I/O device.

The method is compatible with dual oxide dielectric thicknesses since dielectric layers **39** and **41** may both be SiO<sub>2</sub> and have differing thicknesses. Those skilled in the art will recognize that the method can be expanded to include three or more gate dielectric layers with differing SiO<sub>2</sub> thicknesses by repeating the steps depicted in FIGS. 2d and 2e for each additional gate dielectric layer.

An advantage of the second embodiment over prior art is that a device containing a high k dielectric layer which enables the low power device to meet future requirements of <1.8 nm EOT is formed on the same substrate with a high performance device having a gate dielectric EOT that is extendable to <1 nm for 50 nm and 70 nm technology nodes. Furthermore, an I/O device that provides greater SOC capability is also formed on the same substrate. Gate leakage current has been suppressed to an acceptable level in the low power device. The method can be readily implemented in a manufacturing scheme at a minimal cost, especially when the high k dielectric anneal step is performed in-situ with the deposition of the second gate dielectric layer.

While this invention has been particularly shown and described with reference to, the preferred embodiments thereof, it will be understood by those skilled in the art that various changes in form and details may be made without departing from the spirit and scope of this invention.

We claim:

1. A structure having a first device in a first area and a second device in a second area on a substrate, comprising:

an interfacial layer having a first thickness formed on said first area;

a high dielectric-constant (k) dielectric stack having a second thickness [formed on] *overlying* said interfacial layer *and not overlying said second area*;

a first gate electrode formed on said high k dielectric stack; an ultra thin dielectric layer having a third thickness disposed on the second [region] *area*; and

a second gate electrode formed on said ultra thin dielectric layer.

2. The structure of claim 1 wherein the interfacial layer is comprised of silicon nitride, silicon oxide, or silicon oxynitride.

3. The structure of claim 1 wherein the high k dielectric stack is comprised of one or more of Ta<sub>2</sub>O<sub>5</sub>, TiO<sub>2</sub>, Al<sub>2</sub>O<sub>3</sub>, ZrO<sub>2</sub>, HfO<sub>2</sub>, Y<sub>2</sub>O<sub>3</sub>, L<sub>2</sub>O<sub>3</sub>, and their aluminates and silicates.

4. The structure of claim 1 wherein the second thickness is from about 15 to 100 angstroms.

5. The structure of claim 1 wherein the first and second gate electrodes are comprised of doped or undoped polysilicon.

6. The structure of claim 1 wherein the ultra thin dielectric layer is comprised of silicon oxide or silicon oxynitride with an effective oxide thickness of less than 10 angstrom.

7. The structure of claim 1 wherein the ultra thin dielectric layer is silicon oxynitride and the high k dielectric stack is comprised of ZrO<sub>2</sub> and Al<sub>2</sub>O<sub>3</sub>.

8. The structure of claim 1 wherein the ultra thin dielectric layer is SiO<sub>2</sub> and the high k dielectric stack is comprised of HfO<sub>2</sub>.

9. The structure of claim 1 further comprising a silicide layer formed on the gate electrode [layer] and on the [semiconductor] substrate about heavily doped source/drain regions.

10. A structure having a first device in a first area, a second device in a second area, and a third device in a third area on a semiconductor substrate, comprising:

an interfacial layer having a first thickness formed on said first area;

a high dielectric-constant (k) dielectric stack having a second thickness formed on said interfacial layer;

a first gate electrode formed on said high k dielectric stack; an ultra thin dielectric layer having a third thickness formed on the second area;

a second gate electrode formed on said ultra thin dielectric layer;

a second gate dielectric layer having a fourth thickness formed on said third area; and

a third gate electrode formed on said second dielectric layer.

11. The structure of claim 10 wherein the interfacial layer is comprised of silicon nitride, silicon oxide, or silicon oxynitride with a thickness up to about 30 angstrom.

12. The structure of claim 10 wherein the high k dielectric stack is comprised of one or more of Ta<sub>2</sub>O<sub>5</sub>, TiO<sub>2</sub>, Al<sub>2</sub>O<sub>3</sub>, ZrO<sub>2</sub>, HfO<sub>2</sub>, Y<sub>2</sub>O<sub>3</sub>, L<sub>2</sub>O<sub>3</sub>, and their aluminates and silicates.

13. The structure of claim 10 wherein the second thickness is from about 15 to 100 angstroms.

14. The structure of claim 10 wherein said first, second, and third gate electrodes are comprised of doped or undoped polysilicon.

15. The structure of claim 10 wherein the ultra thin dielectric layer is comprised of silicon oxide or silicon oxynitride with an effective oxide thickness of less than 10 angstrom.

16. The structure of claim 10 wherein the second dielectric layer is SiO<sub>2</sub> with a thickness from about 10 to 100 angstrom.

17. The structure of claim 10 wherein the ultra thin dielectric layer is silicon oxynitride and the high k dielectric stack is comprised of ZrO<sub>2</sub> and Al<sub>2</sub>O<sub>3</sub>.

18. The structure of claim 10 wherein the ultra thin dielectric layer is SiO<sub>2</sub> and the high k dielectric stack is comprised of HfO<sub>2</sub>.

19. The structure of claim 10 further comprising a silicide layer formed on said substrate above heavily doped source/drain regions and on said first, second, and third gate electrodes.

20. The structure of claim 1 wherein the first device comprises a low power device and the second device comprises a high performance device.

21. The structure of claim 1 wherein the first thickness is up to about 30 angstrom.

22. The structure of claim 10 wherein the first device comprises a low power device, the second device comprises a high performance device, and the third device comprises an input/output device.

23. A structure that includes a MOSFET which is a low power device formed on a first device area and an adjacent MOSFET which is a high performance device formed on a second device area on a substrate, comprising:

a substrate having shallow trench isolation (STI) regions that separate a first device area from a second device area, said first and second device areas include lightly doped and heavily doped source/drain regions;

an interfacial layer having a first thickness formed on said first device area;

a high k dielectric stack having a second thickness formed on said interfacial layer;

a first gate electrode with a spacer on each of its two sides formed on said high k dielectric stack;

an ultra thin dielectric layer having a third thickness disposed on the second [region] *device area*; and

a second gate electrode with a spacer on each of its two sides formed on said ultra thin dielectric layer.

11

24. A structure having a first device in a first area and a second device in a second area on a substrate, the structure comprising:

a high dielectric-constant (k) dielectric stack having a first thickness overlying the first area and not overlying the second area;

a first gate electrode formed over and physically contacting said high k dielectric stack;

an ultra thin dielectric layer having a second thickness disposed overlying the second area; and

a second gate electrode formed over and physically contacting said ultra thin dielectric layer, the first gate electrode is a same material as the second gate electrode.

25. The structure of claim 24 wherein the high k dielectric stack is comprised of one or more of  $Ta_2O_5$ ,  $TiO_2$ ,  $Al_2O_3$ ,  $ZrO_2$ ,  $HfO_2$ ,  $Y_2O_3$ ,  $La_2O_3$ , and their aluminates and silicates.

26. The structure of claim 24 wherein the first thickness is from about 15 to 100 angstroms.

27. The structure of claim 24 wherein the ultra thin dielectric layer is comprised of silicon oxide or silicon oxynitride with an effective oxide thickness of less than about 10 angstroms.

28. The structure of claim 24 wherein the ultra thin dielectric layer is comprised of silicon oxide.

12

29. The structure of claim 24 wherein the ultra thin dielectric layer is comprised of silicon oxynitride.

30. The structure of claim 24 further comprising an interfacial layer formed overlying the first area.

31. The structure of claim 30 wherein the interfacial layer is comprised of silicon nitride, silicon oxide, or silicon oxynitride.

32. A structure having a first device in a first area and a second device in a second area on a substrate, the structure comprising:

a high dielectric-constant (k) dielectric stack having a first thickness overlying the first area and not overlying the second area, the high k dielectric stack comprising a metal oxide;

a first gate electrode formed overlying said high k dielectric stack;

an ultra thin silicon oxynitride or dioxide layer having a second thickness disposed overlying the second area; and

a second gate electrode formed overlying said ultra thin silicon oxynitride or dioxide layer.

\* \* \* \* \*