

May 9, 1933.

C. C. MOLER

1,908,165

OVERHEAD DOOR CONSTRUCTION

Filed Sept. 4, 1930

3 Sheets-Sheet 1

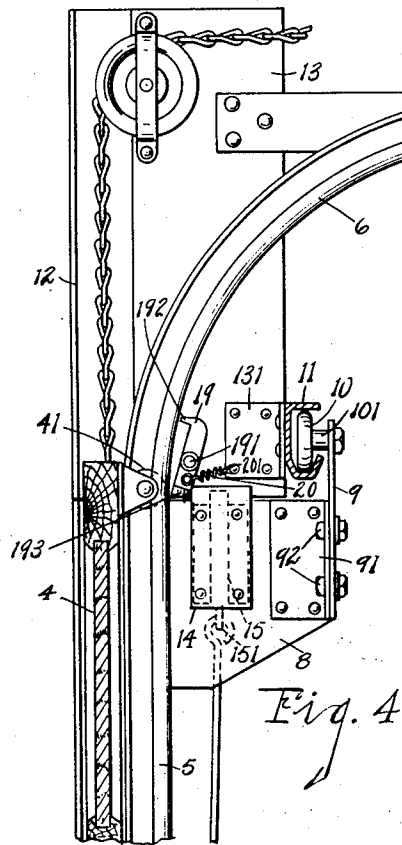
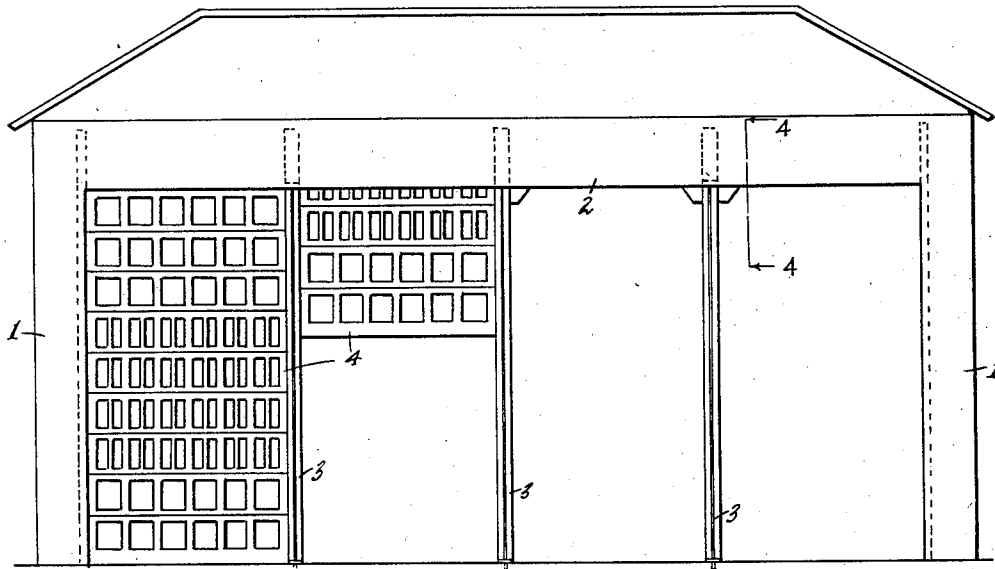

Fig. 4

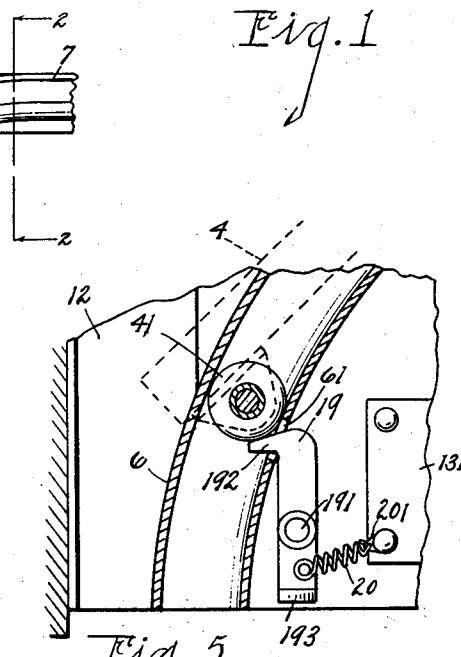

Fig. 5

INVENTOR
Charles C. Moler
BY *Chapman & Earl*
ATTORNEYS

May 9, 1933.

C. C. MOLER

1,908,165

OVERHEAD DOOR CONSTRUCTION

Filed Sept. 4, 1930

3 Sheets-Sheet 2

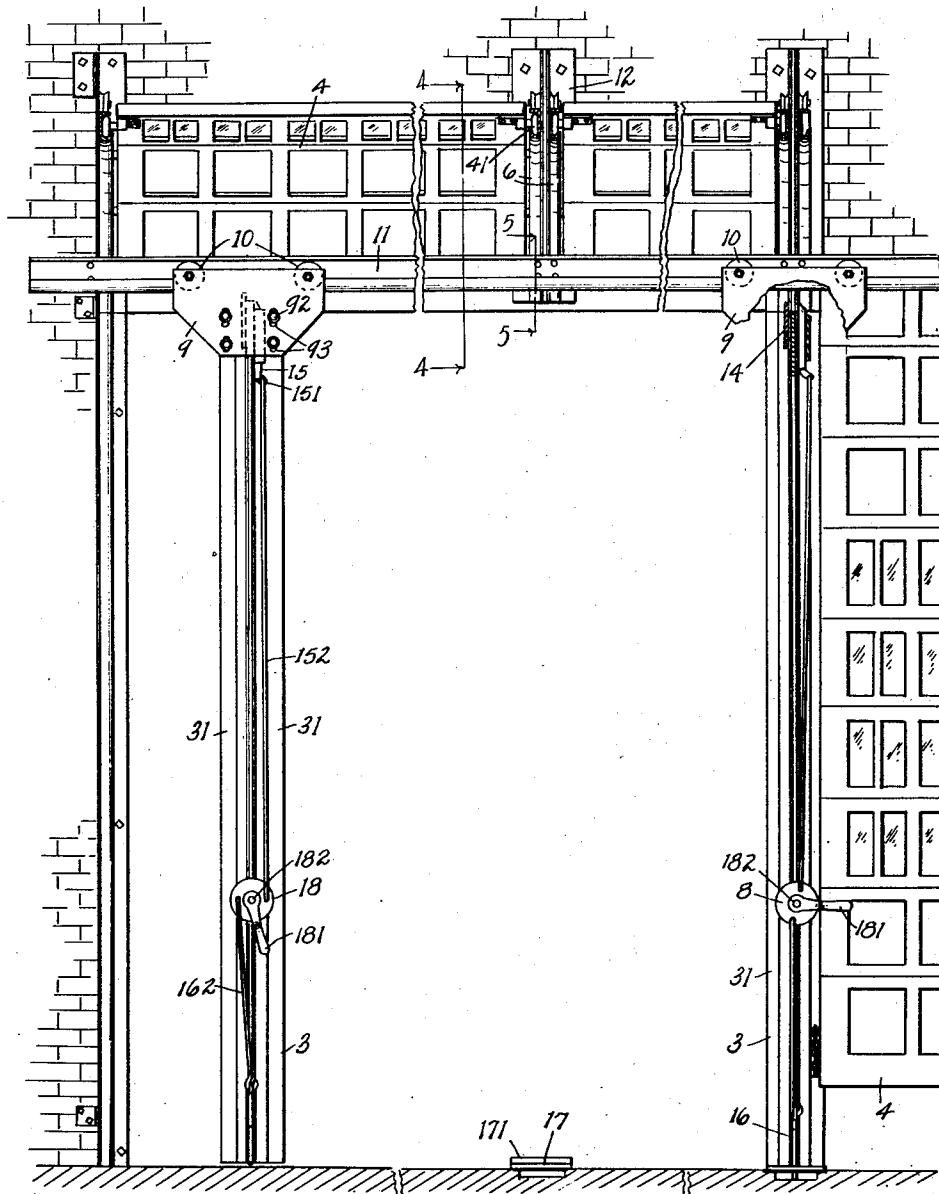

Fig. 2

INVENTOR
Charles C. Moler
BY *Chappell & Earl*
ATTORNEYS

May 9, 1933.

C. C. MOLER

1,908,165

OVERHEAD DOOR CONSTRUCTION

Filed Sept. 4, 1930

3 Sheets-Sheet 3

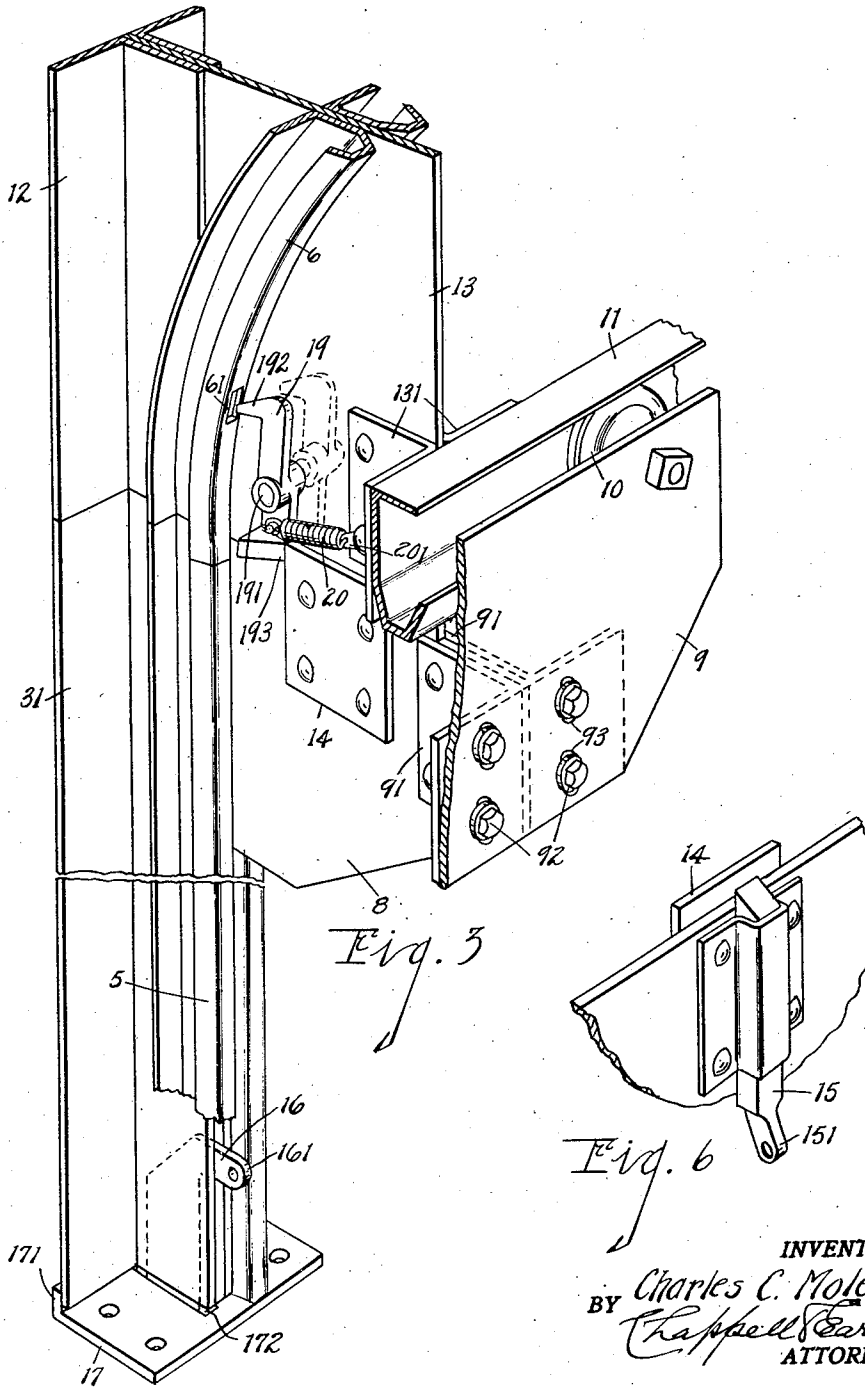

INVENTOR
BY Charles C. Moler
Chappell & Earl
ATTORNEYS

UNITED STATES PATENT OFFICE

CHARLES C. MOLER, OF HARTFORD CITY, INDIANA, ASSIGNOR TO OVERHEAD DOOR CORPORATION, OF HARTFORD CITY, INDIANA

OVERHEAD DOOR CONSTRUCTION

Application filed September 4, 1930. Serial No. 479,683.

This invention relates to improvements in overhead door construction in which a series of doors are separated by removable posts whereby, when the doors are open, the posts can be removed to one side or the other, clearing the entire door space.

The objects of the invention are:

First, to provide such a structure with effective removable door posts.

Second, to provide improved locking means for retaining said door posts in place.

Third, to provide improved locking means to prevent the closing of the doors when the posts are removed.

Fourth, to provide improved transverse track and transporting means for transporting such posts to the side of the door.

Objects pertaining to details and economies of construction and operation will appear from the description to follow. A preferred embodiment of my invention is illustrated in the accompanying drawings, in which:

Fig. 1 is a front elevation view of a building having a broad door opening extending substantially the width of the building with a series of posts dividing the same into doorways for the operation of single door sections or single separate doors.

Fig. 2 is an enlarged detail of the structure appearing in Fig. 1 taken from the inside of the building, being substantially in section on line 2—2 of Fig. 4, the same being shown in broken sections.

Fig. 3 is an enlarged detail perspective of one of the posts, the transverse track and the lock means for the door in their operative position, one of the door lock latches being shown by dotted lines.

Fig. 4 is an enlarged detail vertical sectional view taken on line 4—4 of Figs. 1 and 2, showing the details of the upper ends of the posts and the supporting and transporting means, and the lock means for holding the door in open position.

Fig. 5 is an enlarged detail sectional elevation view taken on line 5—5 of Fig. 2, showing the position of the door locking latch when the door is in elevated or open position.

Fig. 6 is an enlarged detail perspective view of the stop and lock latch for the upper end of one of the posts.

The parts will be identified by their numerals of reference which are the same in all the views.

1, 1 are the side frames or door jambs of the broad door opening. 2 is the top frame of the entire doorway. 3, 3, 3 are the removable posts which carry the vertical tracks for overhead doors 4, such as those illustrated at the left of Fig. 1, one door being entirely closed and the other partially open, the doors to the right being entirely open. The doors 4 are flexible doors made up of a series of horizontal panels hinged together so that they can travel in the vertical track 5, thence into the curved portion of track 6, and then into the horizontal portion 7 above, the parts being indicated particularly in Fig. 4.

A guide roller 41 is secured to each door panel section and projects to travel in the said tracks in the well-known manner of the door known as the "overhead door". Each door post is made up of a pair of upright angle bars 31. These are held in spaced relation at the top by plate 8 which projects inwardly from the posts into the building. A front plate 9 is secured to the forward edge of the plate 8 by a pair of angle brackets 91. The plate 9 is adjustable thereon by bolts 92 in the slots 93, see particularly Fig. 3. A pair of outwardly projecting rollers 10 are carried on journal pins 101 on plate 9 and are disposed in the inclined cross track 11 which is carried on fixed parts above to be later described. This track is a very little higher at the end toward which the disconnected posts are moved so that in moving the posts they will clear the floor.

Fixed post members 12 corresponding to

the angle bars 31, 31 are secured to the wall and are provided with supporting plate 13, corresponding to the plate 8 below. To this plate 13 are secured the curved portions of track 6, in the same relations as the vertical tracks 5 below, the lower ends thereof registering with the tracks 5 on the posts when the posts are in operative position. Transverse track 11 is secured to the plates 13 by angle brackets 131 in the inclined relation previously referred to. The incline is about two inches for the width of an eight foot door.

It will thus be seen that when the posts are released they can be removed along the track to the side of the doorway within the return wall and as many posts accommodated as space permits or as the door opening requires.

The upper end of each post is provided with a stop plate 14, see Figs. 4 and 6, secured to the plate 8 and adapted to contact with one side of the lower edge of upper plate 13 to secure the alignment of the door post in working position. On the opposite side of plate 8 is disposed latch bolt 15, suitably supported, to move into position and retain the post definitely in place. A vertically operating lock bolt 16 is guided between the lower ends of the angle plates 31 constituting the post. Underneath the post is a floor plate 17 with a central slot or socket 172 to receive the lower end of the bolt 16. This floor plate 17 is provided with a stop rib 171 to receive and guide the lower end of the post. The bolt 16 is provided with a perforated ear 161, and the lower end of bolt 15 is provided with an eye 151. A circular pivoted actuating plate 18 with handle 181 is pivoted at 182 on the inner side of each post. Links 162 extend upwardly from the bolts 16 to one side of this operating plate 18. Links 152 extend down from the eye 151 on the bolt 15 to the opposite side of the disk 18.

It will thus be seen that when the disk is moved to the position seen at the left of Fig. 2, where the post has been released, both of these latch bolts have been withdrawn so that the post can be moved freely along the track 11. When the post is in position, as seen at the right hand of Fig. 2, the lever is moved to a position at right angles to that appearing at the left and the bolts are forced into engagement and retain the posts effectively in place. The action of these bolts could of course be accentuated by springs but it is not necessary. The actuating means is like that often used for door bolts.

Because of the incline of the track 11 as above pointed out, the lower ends of the posts clear the floor until they are moved to their particular location. Because of this fact, the lower ends of the posts can swing laterally of the supporting track 11 and into the room or building closed by the door, pivoting on their supporting wheels 10 in their

tracks 11, as seen in cross section in Fig. 4, and thus permitting the clearance of the upper ends of the plates 14 until the posts slide down to their particular positions, when the upper end of plate 14 will engage the corresponding plate 13 and the latch 15 may be permitted to engage.

This clearance can, of course, be accomplished by making the edges of the plates 13 successively of slightly different relative height, but the extent of the engagement is so small that this provision is not a necessity, the swinging of the lower ends of the posts being sufficient.

It will be very clear that when the doors are open under these circumstances and the posts removed, it would be a very serious matter if anyone should close one of the doors. It would drop down out of the curved tracks 6 and it might not be very readily replaced. At any rate the swinging door would be highly undesirable. I therefore provide automatic means for locking and retaining each open door in elevated position when the post is removed.

To accomplish this I provide a pair of pivoted lock latches 19 supported on rock-shaft 191, each with a hooked engaging end 192 adapted to project through apertures 61 in the track 6. I connect spring 20 to the lower end of this latch and the opposite end of the spring to an eye 201 on the bracket 131. This tends to hold the latches always in engagement. The lower end of the left hand latch 19 I offset at 193, providing the same with a beveled cam surface disposed to be contacted with the outer edge of the stop plate 14 on the removable post, so that when the post is forced into position the edge of stop plate 14 slides along the bevel 193 and cams and forces the lower end of the latch outwardly, withdrawing the engaging locking portion 192 from the track 6.

Thus it will be seen that automatically, when the door post is removed, and it can only be removed when the door is open, the lock latch 19 swings to position and locks the door in open position.

This structure can be varied greatly in detail. The transverse track can be used with any sort of attaching and supporting means for the post, although it has special advantages in the arrangement here shown. The track might be dispensed with, and, as the posts are not unduly heavy they might be carried by an attendant and inserted in place. This, however, would be a matter of very considerable inconvenience.

The lever means for operating the bolts at top and bottom simultaneously might be dispensed with but it is very convenient and automatically holds the bolts in withdrawn position ready to be inserted when the post is set into place. All of this is of advantage.

Separate and distinct locks might be pre-

pared for locking the doors open, but it is far better to have this done automatically.

Having thus described my invention what I claim as new and desire to secure by Letters Patent is:

1. In an overhead door structure having a flexible door with vertical front and horizontal overhead tracks and curved intermediate tracks, a transverse track supported within the curved intermediate tracks, a plurality of doors, a removable door post disposed between the said doors and having vertical sections of track adapted to register with the lower ends of the curved tracks, brackets carrying rollers at the top of said post to travel in the transverse track, post connections above the removable posts to which the curved tracks are secured, a stop plate on the upper end of the post structure, a lock bolt associated with said stop to engage and lock the upper end of the post in alignment and in place, a lock bolt at the bottom of the said post, and a rocking pivoted plate carried within the said post between the said bolts and having proper connections thereto whereby the top and bottom bolts may be operated simultaneously and retained in drawn position.

2. In an overhead door structure having a flexible door with vertical front and horizontal overhead tracks and curved intermediate tracks, a transverse track supported within the curved intermediate tracks, a plurality of doors, a removable door post disposed between the said doors and having vertical sections of track adapted to register with the lower ends of the curved tracks, brackets carrying rollers at the top of said post to travel in the transverse track, pivoted lock latches carried by the fixed structure with projecting ends adapted to project through apertures in the said curved track to provide lock stops for retaining the doors in open position, spring means for holding the same yieldingly closed, a cam formed thereon for actuating the same, a stop plate on the upper end of the post structure adapted to coact with the said pivoted lock latch, a lock bolt associated with said stop to engage and lock the upper end of the post in alignment and in place, and a lock bolt at the bottom of the said post.

3. In an overhead door structure having a flexible door with vertical front and horizontal overhead tracks and curved intermediate tracks, a transverse track supported within the curved intermediate tracks, a plurality of doors, a removable door post disposed between the said doors and having vertical sections of track adapted to register with the lower ends of the curved tracks, brackets carrying rollers at the top of said post to travel in the transverse track, post connections above the removable posts to which the curved tracks are secured, a trans-

verse track suitably supported above the posts and within the said curved track, a stop plate on the upper end of the post structure, a lock bolt associated with said stop to engage and lock the upper end of the post in alignment and in place, and a lock bolt at the bottom of the said post.

4. In an overhead door structure having a flexible door with vertical front and horizontal overhead tracks and curved intermediate tracks, a transverse track supported within the curved intermediate tracks, a plurality of doors, a removable door post disposed between the said doors and having vertical sections of track adapted to register with the lower ends of the curved tracks, brackets carrying rollers at the top of said post to travel in the transverse track, post connections above the removable posts to which the curved tracks are secured, a transverse track suitably supported above the posts and within the said curved track, pivoted lock latches carried by the fixed structure with projecting ends adapted to project through apertures in the said curved track to provide lock stops for retaining the doors in open position, spring means for holding the same yieldingly closed, a cam formed thereon for actuating the same, a stop plate on the upper end of the post structure adapted to coact with the said pivoted lock latch, and means for detachably supporting said post.

5. In an overhead door structure, the combination with a flexible door and tracks therefor, of a removable post, an inclined transverse track disposed and supported beneath the overhead tracks, and a bracket on the said post having rollers disposed at each side to travel in said transverse track, whereby the post may be transferred to the side of the doorway.

6. In an overhead door structure, the combination with a flexible door and tracks therefor, of a removable post, a transverse track disposed and supported beneath the overhead tracks, and a bracket on the said post having rollers disposed at each side to travel in said transverse track, whereby the post may be transferred to the side of the doorway.

7. An overhead door structure comprising a plurality of flexible doors and vertical and horizontal tracks and intermediate curved tracks therefor, an intermediate removable post, a pivoted lock on the said curved tracks to hold the doors in open position when the posts are removed, and automatic means disposed to be tripped by said post to actuate said lock when the removable post is replaced.

8. An overhead door structure comprising a plurality of flexible doors and vertical and horizontal tracks and intermediate curved tracks therefor, an intermediate removable post, a lock on the said curved tracks to hold the doors in open position when the posts are

removed, and automatic means disposed to be tripped by said post to actuate said lock when the removable post is replaced.

9. An overhead door structure comprising a plurality of flexible doors and vertical and horizontal tracks and intermediate curved tracks therefor, an intermediate removable post, and a lock on the said curved tracks to hold the doors in open position when the removable post is replaced.

In witness whereof I have hereunto set my hand.

CHARLES C. MOLER.

15

20

25

30

35

40

45

50

55

60

65