

No. 667,657.

Patented Feb. 5, 1901.

C. HOFMANN.
BALL GRINDING MILL.

(Application filed Sept. 17, 1898.)

(No Model.)

2 Sheets—Sheet 1.

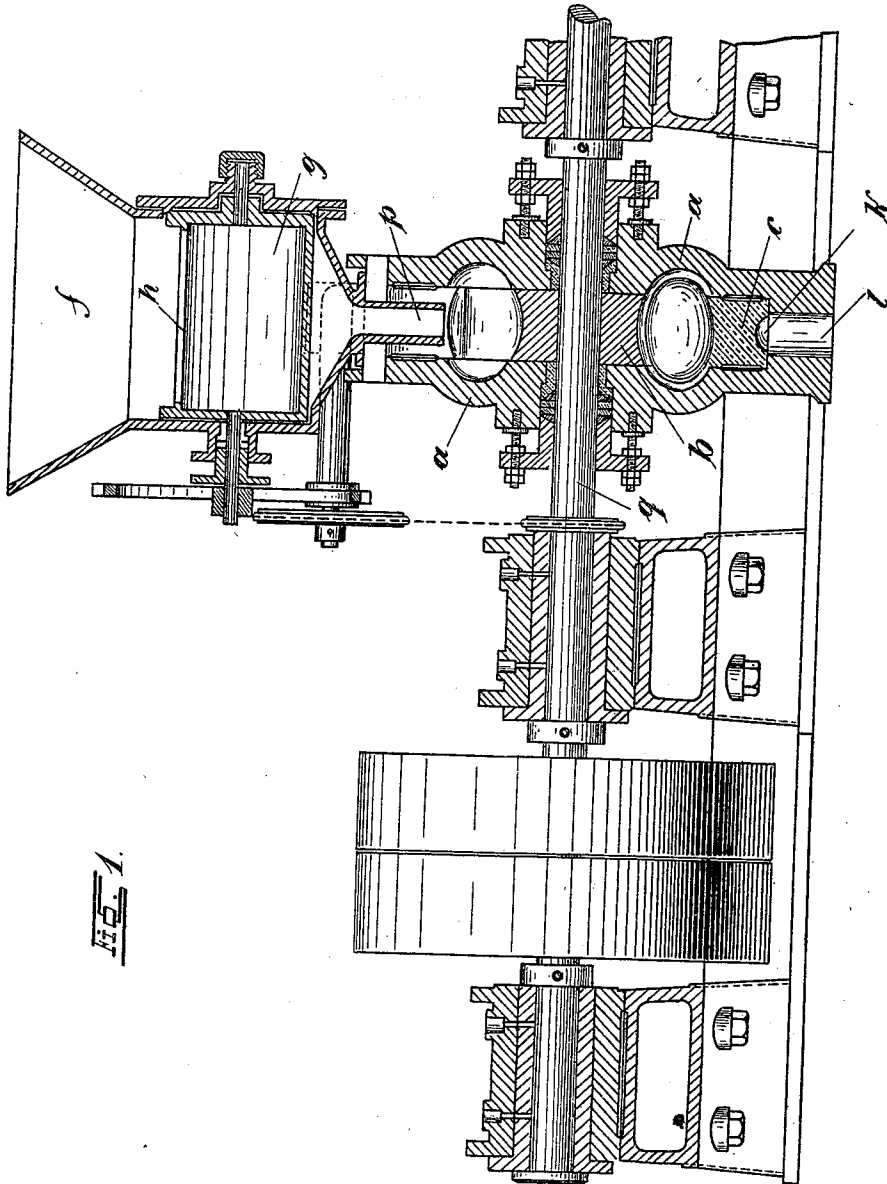

HE 1.

WITNESSES:

M. Henry Wurtzel
M. C. Schmidt

INVENTOR
Carl Hofmann
BY *Lucretia Regener*
ATTORNEYS.

No. 667,657.

Patented Feb. 5, 1901.

C. HOFMANN.
BALL GRINDING MILL.

(Application filed Sept. 17, 1898.)

(No Model.)

2 Sheets—Sheet 2.

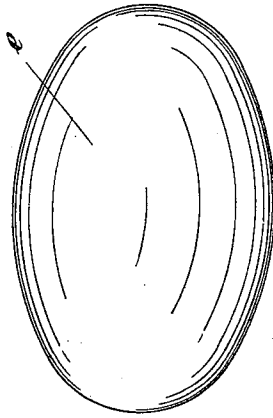

FIG. 3.

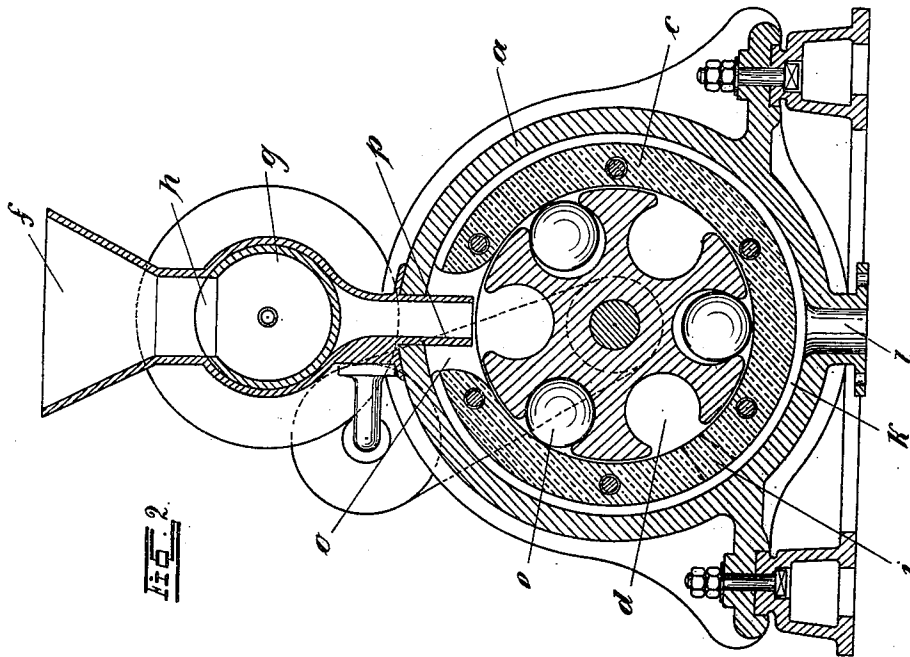

FIG. 2.

WITNESSES:

W. Henry Wurtzel
M. C. Schmidt

INVENTOR
Carl Hofmann
BY *J. W. Rogers*
ATTORNEYS.

UNITED STATES PATENT OFFICE.

CARL HOFMANN, OF BRESLAU, GERMANY.

BALL GRINDING-MILL.

SPECIFICATION forming part of Letters Patent No. 667,657, dated February 5, 1901.

Application filed September 17, 1898. Serial No. 691,156. (No model.)

To all whom it may concern:

Be it known that I, CARL HOFMANN, a citizen of the Empire of Germany, residing at Breslau, in the Province of Silesia and Empire of Germany, have invented certain new and useful Improvements in Ball Grinding-Mills, of which the following is a specification.

This invention relates to grinding, crushing, and like machines of the ball-and-ring type; and its object is to construct a machine which will have great efficiency and which will maintain its efficiency unimpaired for a long period of work.

The invention consists in the combination, in a crushing, pulverizing, or similar machine, of a casing, a rotary disk located within said casing and provided with a number of ellipsoid-shaped compartments, and grinding-bodies of ellipsoid form freely movable in the compartments of the disk and rotating with the same within said casing; and the invention consists, further, in the combination, in a machine of the class stated, of a casing provided at each side with an annular channel, a rotary disk located within said casing and provided with compartments opposite said channels, said compartments and channels forming thereby ellipsoid-shaped receptacles, and ellipsoid-shaped grinding-bodies located in said receptacles and freely movable therein, substantially as hereinafter set forth and claimed.

In the accompanying drawings, Figure 1 represents my improved machine in longitudinal section. Fig. 2 is a transverse section of the machine; and Fig. 3 is a side view of one of the balls, which, however, in my machine are not balls, strictly speaking, but ellipsoid-shaped bodies.

Referring to the drawings, *a* indicates the casing of the machine, which consists of two side plates, between which the ring *c* is securely held in any suitable manner. Supported within the casing on a suitable driving-shaft *g* and capable of rotating within the casing is a disk or wheel *b*, provided with a convenient number of pockets or compartments *d*. The balls *e* are placed in alternate compartments, so that upon the rotation of the disk the empty compartments effect the mixing and circulation of the material to be

crushed, while the balls in the alternate compartments by contact with the casing *a* and ring *c* effect the crushing of the material. As shown in the drawings, the compartments of the disk are ellipsoid-shaped and the casing *a* is provided at each side with an annular channel. The compartments of the disk are located at such distance from the axis of the same as to be opposite the channels, and receptacles of ellipsoid form are thereby formed. The grinding-bodies *e* are of regular ellipsoid shape, but of smaller size than their receptacles, as shown. I have found that these ellipsoid bodies wear very uniformly and retain their true shape even after long wear. In cases where bodies of spherical or cylindrical shape have been used it has been found that they rapidly wear unevenly and soon vary in shape, and that consequently the machine, which has been constructed for a certain form of grinding-body, has its efficiency materially impaired. In my improved machine, however, as the machine is provided at the start with ellipsoid bodies which remain of ellipsoid form the efficiency is not perceptibly decreased.

It is preferred to feed the machine from above and periodically. This may be accomplished by the device illustrated. The hopper *f* is arranged above the casing and contains the hollow rotary cylinder *g*, which may be driven from the main shaft *g*, upon which the disk or wheel *b* is mounted. This cylinder is slotted or is provided with an opening *h* at one or more points, so that when it occupies the position shown in Fig. 2 it receives material from the hopper. Upon the further rotation of the cylinder the supply from the hopper is cut off, and when the opening *h* comes over the outlet *p* of the hopper the contained material is emptied into the casing.

The outlet *i* of the machine is arranged in the ring *c* a little above a horizontal plane, passing through the lowest point of the interior face of the ring, so that some of the material is always in the casing and only that which is properly ground or pulverized makes its exit.

If the machine is to be used for liquid or semiliquid or fluid substances, the outlet will have to be arranged at a definite distance from the bottom. For plastic or dough-like

materials the outlet may be placed lower down.

When a material is to be ground into dust or to a fine powder, a ventilator or blower may be arranged for circulating fresh air and for drawing off the finished product. For this purpose the outer edge of the ring *c* may be channeled, as shown at *k* in Fig. 1, and the exhaust or opening through which the air is drawn is arranged at *l* at the lowest point of the casing. The outlet *i* is of course in this case dispensed with. Air and dust are drawn from the interior of the casing and ring through the opening *o* in the upper part of the ring and pass through the chamber *k*, around the ring, and out through the opening *l*. It is necessary in this case that the inlet *p* for the material be extended down to and almost in contact with the edge of the disk *b*, as shown in the drawings.

The framework and driving mechanism of the machine may be the same as is usually employed in mills of a similar type. It is shown clearly in the drawings and requires no particular description.

I am aware that ellipsoid bodies have been heretofore employed in ball-mills; but in these constructions they have been supported in bearings and not, as in my machine, freely movable in a pocket of corresponding shape. Lateral motion of the bodies was not permit-

ted, and this is essential to efficient grinding action and the uniform wearing down of the bodies and is secured in my machine.

Having thus described my invention, I claim as new and desire to secure by Letters Patent—

1. In a crushing, pulverizing or similar machine, a casing, a rotary disk located within said casing and provided with a number of ellipsoid-shaped compartments, and grinding-bodies of regular ellipsoid form freely movable in the compartments of the disk and rotating with the same within the casing, substantially as set forth.

2. In a crushing, pulverizing or similar machine, a casing provided at each side with an annular channel, a rotary disk located within said casing and provided with compartments opposite said channels, said compartments and channels forming thereby ellipsoid-shaped receptacles, and ellipsoid-shaped grinding-bodies located in said receptacles and freely movable therein, substantially as set forth.

In witness whereof I have hereunto set my hand in presence of two witnesses.

CARL HOFMANN.

Witnesses:

HERMANN BARTSCH,
EDWIN WEISS.