

C. R. P. POOL.
 LIFT FOR GIN BREASTS.
 APPLICATION FILED MAY 22, 1920.

1,380,677.

Patented June 7, 1921.

2 SHEETS—SHEET 1.

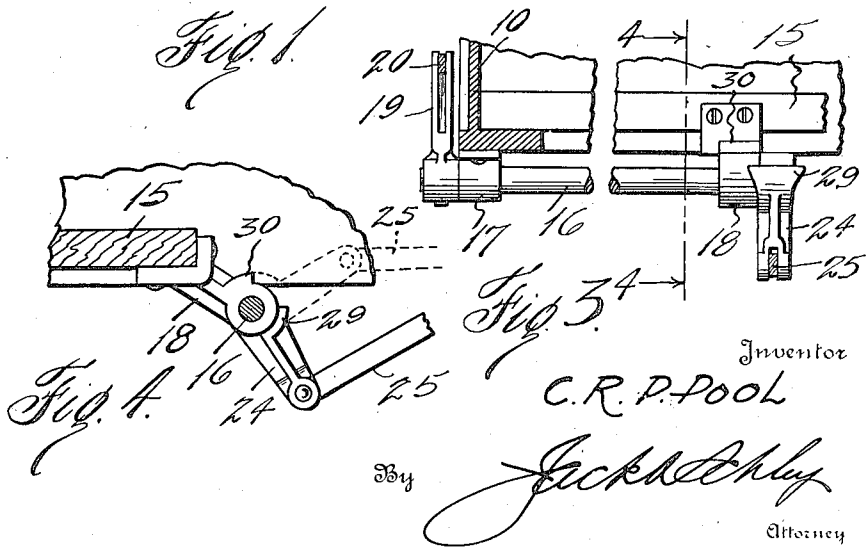
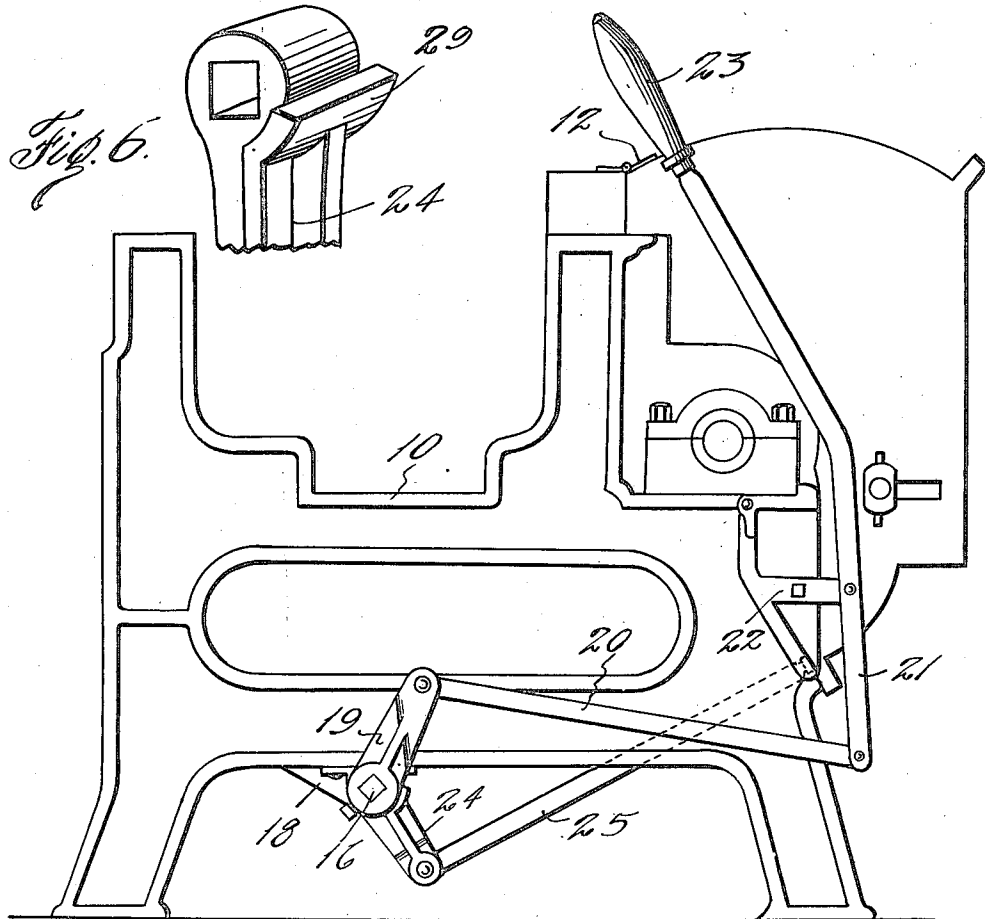

Inventor

C. R. P. POOL

By

Jack R. Schuy
 Attorney

C. R. P. POOL.
LIFT FOR GIN BREASTS.
APPLICATION FILED MAY 22, 1920.

1,380,677.

Patented June 7, 1921.
2 SHEETS—SHEET 2.

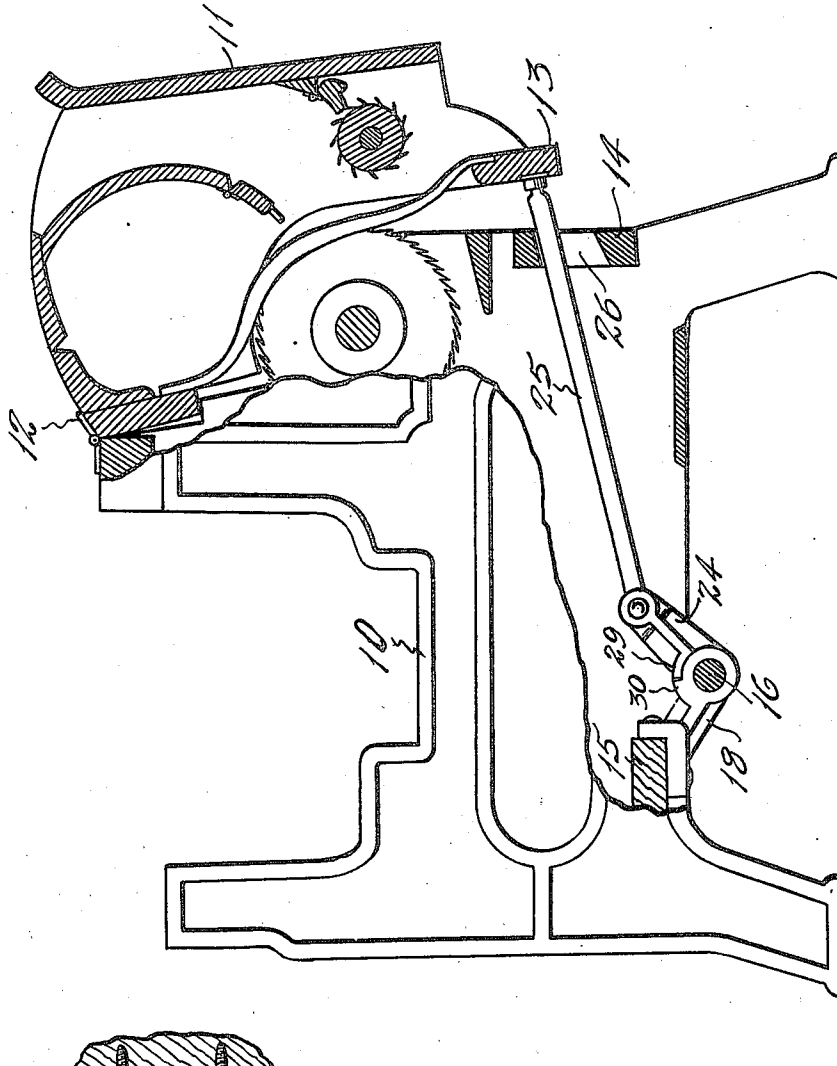

Fig. 4.

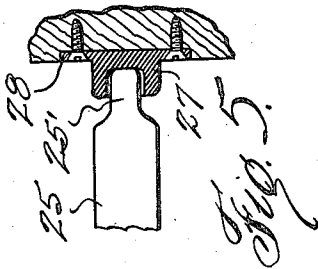

Fig. 5.

Inventor
C. R. P. POOL.

384

Jack Ashley
Attorney

UNITED STATES PATENT OFFICE.

CHARLES R. P. POOL, OF DALLAS, TEXAS.

LIFT FOR GIN-BREASTS.

Specification of Letters Patent. Patented June 7, 1921.

1,380,677.

Application filed May 22, 1920. Serial No. 383,475.

To all whom it may concern:

Be it known that I, CHARLES R. P. POOL, citizen of the United States, residing at Dallas, in the county of Dallas and State of Texas, have invented certain new and useful Improvements in Lifts for Gin-Breasts, of which the following is a specification.

This invention relates to new and useful improvements in lifts for gin breasts.

At certain periods in the operation and manipulation of a cotton gin it is necessary to lift or raise the breast and as the latter is quite heavy it is quite difficult and sometimes dangerous to swing the breast outward in the usual manner. My invention has to do with means including an operating lever whereby a simple movement of said lever will raise or swing the breast outward and a reverse movement of the lever will lower the breast to its working position. It also includes means for safely supporting the breast when the latter is swung outward.

In carrying out the invention a lever is mounted at one end of the gin frame and connected with a rock shaft. The rock shaft has connection with means for swinging the breast outward and so holding the same, when said rock shaft is rocked. Other novel features of the invention will be hereinafter more particularly pointed out.

The invention will be more readily understood from a reading of the following specification and by reference to the accompanying drawings, in which an example of the invention is shown, and wherein:

Figure 1 is an end elevation of a portion of a gin stand showing the breast closed or lowered and an attachment embodying my invention applied thereto,

Fig. 2 is a transverse sectional view showing the gin breast raised,

Fig. 3 is a detail of the rock shaft and component parts,

Fig. 4 is a cross sectional detail on the line 4-4 of Fig. 3,

Fig. 5 is a sectional detail of the wear plate which is attached to the bottom of the breast, and

Fig. 6 is a detail of the lifting arm 24.

In the drawings the numeral 10 designates one of the end frames of a gin stand. The breast 11 is hinged to the stand at 12 and is constructed in the usual way and provided with the lower rib bar 13, the rest

bar 14 and the usual sill 15. These parts are found in the ordinary gin construction and form no part of the invention.

My invention includes a longitudinal rock shaft 16 which has one end supported in a bearing box 17 depending from the end frame 10 and the other end supported in a bearing member 18 attached to the sill 15 at the central portion of the gin stand. The outer end of the rock shaft 16 is preferably square in cross section and receives an arm 19 which is fastened thereon and projects upwardly on the outside of the frame 10 as shown in Figs. 1 and 3. The upper end of the arm is pivoted to the rear end of a link 20 which extends forward and is pivoted to the lower end of an operating lever 21. The lever 21 is pivoted on a bracket 22 which latter is fastened to the end frame 10. The lever 21 is bent rearwardly and carries a handle 23 at its upper end. By grasping the handle 23 and pulling the lever forward the link 20 is pushed rearward and the arm 19 swung rearwardly whereby the rock shaft 16 is rocked.

The inner end of the shaft 16 projects beyond the bearing member 18 and carries an arm 24, which it will be noted normally projects downward from the shaft 16. A pitman or lifting rod 25 has its rear end pivoted to the lower end of the arm 24 and extends through a slot 26 in the bar 14. The bar 13 has on its rear side a wear socket 27 which is provided with a flange 28. By means of the flange 28 the socket is suitably fastened to said bar. The rod 25 has its forward end 25' reduced and engaging in the socket 27.

When the lever 21 is pulled forward the link 20 is swung rearwardly thereby swinging the arm 19 rearwardly, whereby the shaft 16 is rocked. When the shaft 16 is rocked the arm 24 is swung upward and as said arm swings upward the rod 25 is pushed forwardly, whereby the gin breast 11 is swung outwardly as shown in Fig. 2. It will be seen that the arm 24 is swung upward until its pivotal connection with the rod 25 is above a straight line running from the shaft 16 to the socket 27 and thus the breast cannot be lowered or cannot fall until the arm 24 is swung downward to aline the parts or swing them below said imaginary line. To limit the upward movement of the arm 24 a lug 29 is cast on the same and projects on each side as is shown

in Fig. 3. This lug engages a stop 30 on the member 18 which limits the upward swing of said arm 24. By making the lug 29 to project on both sides of the arm 24 said arm may be used on attachments which are applied to either end of the gin stand. In the present illustration the lever 21 is applied to the left hand end of the stand, but it is obvious that it might be applied to the right hand end.

By throwing the arm 24 upward and locking the same a safety attachment is provided and there is no danger of the breast falling until the handle 23 is pushed rearwardly. It will be seen that the lever 21 projects some distance above its pivot point so as to give the operator sufficient leverage to control the operation. The breast may be quickly swung upward or lowered as the case may be. It is believed that the invention will be entirely clear without further explanation of the operation. It is also pointed out that the device may be attached to a gin which is already built.

What I claim, is:

1. In a gin breast lifting attachment, a rock shaft arranged near the bottom of the gin frame, means for supporting said rock shaft from the gin frame, a lever pivotally mounted upon one side of the gin frame remote from the rock shaft, a rocking connection between the lever and rock shaft, a lifting rod adapted to engage the breast of the gin and separate means secured upon the rock shaft and connected with said rod to move same longitudinally.

2. In a gin breast lifting attachment, a rock shaft arranged near the lower portion of the gin frame at a point remote from the gin breast, means for supporting the rock shaft from the gin frame, a lever pivotally connected with the gin frame at a point near the gin breast, a rocking connection between the lever and the rock shaft, a lifting rod adapted to engage the gin breast,

and separate means mounted upon the rock shaft and connected with the rod to move it longitudinally, said means being adapted to automatically lock when the gin breast is raised to the opened position.

3. In a gin breast lifting attachment, the combination with a rock shaft extending longitudinally of the gin frame at a point remote from the gin breast, a bearing supported from the gin frame and receiving the rock shaft, said bearing having a stop abutment, a lever pivotally mounted upon the gin frame, a rocking connection between the lever and the rock shaft, a crank rigidly secured to the rock shaft and having a stop abutment to engage the first named stop abutment, when the crank is swung upwardly past dead center, and a lifting rod engaging the gin breast and pivotally connected with said crank.

4. In a gin breast lifting device the combination with a gin stand, of a rock shaft mounted on said stand, an operating lever pivoted on the stand, an arm connected with the rock shaft, a link pivotally connected with the lever and the arm, a swinging element fastened on the rock shaft, and a lifting member pivoted to the element and engaging the breast for raising the same.

5. In a gin breast lifting device the combination with a gin stand, of a rock shaft mounted on said stand, an operating lever pivoted on the stand, an arm connected with the rock shaft, a link pivotally connected with the lever and arm, a swinging element fastened on the rock shaft, a lifting member pivoted to the element and engaging the breast for raising the same, and means for limiting the upward swing of the swinging element and locking the parts whereby the gin breast is supported in its raised position.

In testimony whereof I affix my signature.

CHARLES R. P. POOL.