

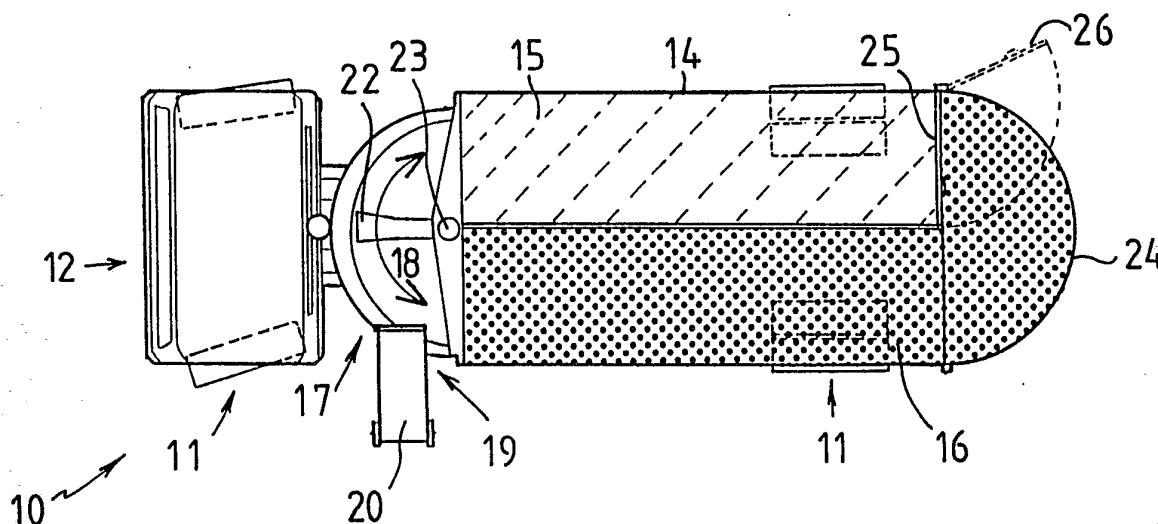

INTERNATIONAL APPLICATION PUBLISHED UNDER THE PATENT COOPERATION TREATY (PCT)

<p>(51) International Patent Classification ⁵ : B65F 3/20, 3/12</p>	<p>A1</p>	<p>(11) International Publication Number: WO 93/15982</p> <p>(43) International Publication Date: 19 August 1993 (19.08.93)</p>																		
<p>(21) International Application Number: PCT/AU93/00052</p> <p>(22) International Filing Date: 10 February 1993 (10.02.93)</p> <p>(30) Priority data:</p> <table border="0"> <tr> <td>PL 0792</td> <td>10 February 1992 (10.02.92)</td> <td>AU</td> </tr> <tr> <td>PL 1123</td> <td>28 February 1992 (28.02.92)</td> <td>AU</td> </tr> <tr> <td>PL 1150</td> <td>3 March 1992 (03.03.92)</td> <td>AU</td> </tr> <tr> <td>PL 1884</td> <td>13 April 1992 (13.04.92)</td> <td>AU</td> </tr> <tr> <td>PL 4326</td> <td>26 August 1992 (26.08.92)</td> <td>AU</td> </tr> <tr> <td>PL 5467</td> <td>22 October 1992 (22.10.92)</td> <td>AU</td> </tr> </table> <p>(71) Applicant (for all designated States except US): FIREBELT PTY. LIMITED [AU/AU]; 10-12 Pacific Highway, Chinderah, NSW 2487 (AU).</p> <p>(72) Inventor; and (75) Inventor/Applicant (for US only) : RICHARDS, Idwall, Charles [AU/AU]; 48 Terranora Road, Banora Point, NSW 2486 (AU).</p>		PL 0792	10 February 1992 (10.02.92)	AU	PL 1123	28 February 1992 (28.02.92)	AU	PL 1150	3 March 1992 (03.03.92)	AU	PL 1884	13 April 1992 (13.04.92)	AU	PL 4326	26 August 1992 (26.08.92)	AU	PL 5467	22 October 1992 (22.10.92)	AU	<p>(74) Agent: TREVOR DREDGE & ASSOCIATES; G.P.O. Box 1339, Brisbane, QLD 4001 (AU).</p> <p>(81) Designated States: AT, AU, BB, BG, BR, CA, CH, CZ, DE, DK, ES, FI, GB, HU, JP, KP, KR, LK, LU, MG, MN, MW, NL, NO, NZ, PL, PT, RO, RU, SD, SE, SK, UA, US, European patent (AT, BE, CH, DE, DK, ES, FR, GB, GR, IE, IT, LU, MC, NL, PT, SE), OAPI patent (BF, BJ, CF, CG, CI, CM, GA, GN, ML, MR, SN, TD, TG).</p> <p>Published With international search report.</p>
PL 0792	10 February 1992 (10.02.92)	AU																		
PL 1123	28 February 1992 (28.02.92)	AU																		
PL 1150	3 March 1992 (03.03.92)	AU																		
PL 1884	13 April 1992 (13.04.92)	AU																		
PL 4326	26 August 1992 (26.08.92)	AU																		
PL 5467	22 October 1992 (22.10.92)	AU																		

(54) Title: A SIDE-LOADING REFUSE VEHICLE



(57) Abstract

A side loading refuse vehicle (10) having a wheel assembly (11) supporting a cab (12) and a chassis (13), a storage tank (14) having two tank sections (15 and 16) is mounted on the chassis (13). A hopper (17) having a loading aperture (18) is located behind the cab (12), the hopper is adapted to receive refuse from a loading mechanism (19) adjacent the hopper so that the contents of a multi-compartment bin (20), which in this case includes a central divider partition (21) shown in phantom in Figure 1, can be partially inverted over the hopper (17) so that the contents of the bin (20) are diverted into the respective tank sections (15 and 16) by the refuse transfer mechanism in the hopper (17).

FOR THE PURPOSES OF INFORMATION ONLY

Codes used to identify States party to the PCT on the front pages of pamphlets publishing international applications under the PCT.

AT	Austria	FR	France	MR	Mauritania
AU	Australia	GA	Gabon	MW	Malawi
BB	Barbados	GB	United Kingdom	NL	Netherlands
BE	Belgium	GN	Guinea	NO	Norway
BF	Burkina Faso	GR	Greece	NZ	New Zealand
BG	Bulgaria	HU	Hungary	PL	Poland
BJ	Benin	IE	Ireland	PT	Portugal
BR	Brazil	IT	Italy	RO	Romania
CA	Canada	JP	Japan	RU	Russian Federation
CF	Central African Republic	KP	Democratic People's Republic of Korea	SD	Sudan
CG	Congo	KR	Republic of Korea	SE	Sweden
CH	Switzerland	KZ	Kazakhstan	SK	Slovak Republic
CI	Côte d'Ivoire	LJ	Liechtenstein	SN	Senegal
CM	Cameroon	LK	Sri Lanka	SU	Soviet Union
CS	Czechoslovakia	LU	Luxembourg	TD	Chad
CZ	Czech Republic	MC	Monaco	TG	Togo
DE	Germany	MG	Madagascar	UA	Ukraine
DK	Denmark	ML	Mali	US	United States of America
ES	Spain	MN	Mongolia	VN	Viet Nam
FI	Finland				

A SIDE-LOADING REFUSE VEHICLE

TECHNICAL FIELD OF THE INVENTION

THIS INVENTION relates to a refuse vehicle and in particular, to a side loading refuse vehicle and more particularly, but not limited to, an automated side loading refuse vehicle for simultaneous collection, but separate storage of garbage and/or recyclable wastes in the one vehicle.

BACKGROUND ART

10 With the introduction of environmental awareness, the collection of domestic garbage has taken on a new complexion, it being realised that new, convenient and economical approaches to garbage collection and recycling must be introduced. It has been proposed to provide
15 householders with a plurality of waste bins so that each householder can sought waste into various categories.

For example, paper, metal cans and bottles and garbage could conceivably be stored and collected separately and this has been tried, the main problem with this scheme is
20 the high expense insofar as separate collections are required for each category.

The alternative has been to provide local or regional sorting facilities where garbage is hand sorted or expensive automated facilities have been tried with minimal
25 success due to the high expense involved.

In summary therefore, sorting of recyclables from domestic garbage after collection is generally uneconomical.

OUTLINE OF THE INVENTION

30 The present invention has, as its primary object, to provide a useful alternative to the aforementioned prior art.

In one aspect, the present invention resides in a side loading refuse vehicle including the combination of an
35 elongate refuse storage tank divided into longitudinally extending tank sections, a loading mechanism adjacent a side of the refuse vehicle and a refuse transfer mechanism

for delivering refuse or other material emptied into the vehicle by the loading mechanism to the respective tank sections.

5 The storage tank typically has arcuate side walls and is preferably generally square and medially bulged in shape.

The storage tank of the refuse vehicle typically has a plurality of tank sections and typically has two or three tank sections although more tank sections may be employed.

10 The tank sections can comprise side-by-side or upper and lower storage regions or combinations of these. The storage regions typically have respective forward and rearward ends and respective entrances adjacent the forward ends through which refuse can enter the regions.

15 Typically, the tank sections have respective discharge doors with one discharge door being operatively located outside the other discharge door or doors so that the tank sections can be discharged sequentially.

20 Where an upper storage region is employed, it typically includes a sloping floor which slopes down toward the forward end of the upper storage region so that as the vehicle travels, the sloping floor causes compaction of refuse toward the forward end of the upper storage region.

25 The transfer mechanism typically includes means for receiving and selectively diverting refuse from a bin, the bin either having two compartments which are side-by-side as the bin is emptied, or having two compartments which are one above the other as the bin is emptied, the transfer mechanism operating so that refuse from the compartments is maintained separate as the refuse is moved to the
30 respective tank sections.

The refuse transfer mechanism typically includes a passive or active mechanism or a combination of passive and active mechanisms selected from the following:-

- 35 (i) automated bin lid opening devices;
(ii) retractable refuse diversion chutes or bin compartment alignment means;

- (iii) bin compartment alignment means which aligns with or abuts against a compartment defining portion of a bin so that refuse from the bin remains separate as it flows or is moved from the bin, through the transfer mechanism and finally into the tank sections;
- 5 (iv) a refuse compaction device;
- (v) a longitudinally moveable oscillating slide packer; or
- (vi) a packer which includes an oscillating blade which oscillates about a substantially vertical axis relative to the longitudinal direction of the tank sections.
- 10

The transfer mechanism can move material within the tank sections and in one embodiment a conveyor can be used in one or more of the tank sections so that refuse can be conveyed along the tank sections. Typically, the conveyor is an endless belt conveyor or a travelling floor conveyor.

15

In one preferred form, the transfer mechanism typically comprises a hopper communicating with the tank sections and means for selectively diverting refuse or other material delivered into the hopper by the loading mechanism to the respective tank sections.

20

In another preferred embodiment, the transfer mechanism comprises a hopper and an oscillating blade in the hopper being adapted to sweep through the hopper to alternately sweep refuse or other material delivered into the hopper by the loading mechanism to one side and then to another side of the hopper as the blade oscillates back and forth within the hopper, the transfer mechanism having a moveable hopper closure means to partially close the hopper behind the blade so as to prevent material intended to be delivered to one side of the hopper being inadvertently delivered to the other side of the hopper as the blade travels through the hopper.

25

30

Where the tank sections involve upper and lower storage regions, the transfer mechanism typically comprises respective upper and lower transfer mechanisms for selectively diverting refuse or other material through the entrances to the respective upper and lower storage

35

regions.

In another embodiment, the transfer mechanism typically includes a refuse separating means adjacent the loading mechanism and adapted to be located in close proximity to a bin inverted over the separator means by the loading mechanism for separating refuse delivered into the transfer mechanism so the separated refuse is moved to the respective tank sections.

In one typical use, the present invention involves the alignment of compartments in a bin in predetermined geometry with the transfer mechanism. To this end, the vehicle is typically equipped with a bin alignment means including a bin lead-in guide to take into account relative position of a bin on the loading mechanism, the lead-in guide being disposed to move the bin on the loading mechanism as it is emptied so that it is emptied according to the predetermined geometry relative to the transfer mechanism.

BRIEF DESCRIPTION OF THE DRAWINGS

In order that the present invention can be more readily understood and be put into practical effect, reference will now be made to the accompanying drawings and wherein:-

Figure 1 is a pictorial view illustrating one embodiment of a refuse vehicle according to the present invention showing a bin having compartments one above the other being emptied;

Figure 2 is cut-away perspective view of the vehicle of Figure 1 illustrating a further stage in the emptying process;

Figure 3 is a schematic section view illustrating the interior of the refuse vehicle according to Figure 1;

Figures 4 and 5 are schematic sectional views illustrating an embodiment of a transfer mechanism suitable for use in a vehicle according to Figures 1 to 3;

Figure 6 is a schematic cut-away pictorial view illustrating one preferred form of refuse vehicle according

to the present invention having three tank sections;

Figures 7 to 10 illustrate operation of a preferred transfer mechanism for a vehicle of the type illustrated in Figure 6;

5 Figure 11 is a part sectional side view illustrating another embodiment of a refuse vehicle according to the present invention having upper and lower tank sections;

10 Figure 12 is a pictorial view similar to that of Figure 1 of another embodiment of a refuse vehicle according to the present invention showing a bin having side-by-side compartments being emptied;

Figure 13 is a part perspective view illustrating a further stage in the emptying process in relation to the refuse vehicle and bin of Figure 12;

15 Figure 14 is a vertical section through the refuse vehicle as noted in Figures 12 and 13 and illustrating a preferred transfer mechanism for that vehicle;

20 Figure 15 is a part horizontal section through the refuse vehicle illustrated in Figures 12 and 13 and illustrating the transfer mechanism of Figure 14;

Figures 16 and 17 are pictorial views illustrating two different forms of refuse separator means according to preferred embodiments of the present invention and suitable for use with the vehicle of Figures 12 and 13;

25 Figure 18 is a vertical section through a hopper illustrating an alternative embodiment of the present invention involving a bin having two lids;

30 Figure 19 is a pictorial view illustrating part of a tank section suitable for use in a vehicle according to the present invention involving a transfer mechanism having a travelling floor;

Figure 20 is a view from above of a partially assembled travelling floor conveyor suitable for use in a vehicle according to the present invention;

35 Figure 21 is a detailed cut-away view illustrating operation of a travelling floor conveyor suitable for use in a vehicle according to the present invention; and

Figures 22 and 23 are pictorial views illustrating the present invention employing a loading mechanism suspended at the end of a retractable arm assembly.

METHOD OF PERFORMANCE

5 Referring to the drawings and initially to Figures 1, 2 and 3, there is illustrated a side loading refuse vehicle 10 having a wheel assembly 11 supporting a cab 12 and a chassis 13, a storage tank 14 having two tank sections 15 and 16 is mounted on the chassis 13. A hopper 17 having a loading aperture 18 is located behind the cab 12, the hopper is adapted to receive refuse from a loading mechanism 19 adjacent the hopper so that the contents of a multi-compartment bin 20, which in this case includes a central divider partition 21 shown in phantom in Figure 1, can be partially inverted over the hopper 17 so that the contents of the bin 20 are diverted into the respective tank sections 15 and 16 by the refuse transfer mechanism which can be seen in Figure 3 is an oscillating blade 22. The blade 22 oscillates about a vertical axis 23 to alternately sweep and compact refuse delivered into the hopper 17 into the respective tank sections 15 and 16.

15 In the embodiment of Figure 3, the tank section 16 is generally L-shaped having a "bubble" door 24, the tank section 15 includes a door 25 shown in its open position in phantom at 26. In this embodiment, refuse would initially be discharged from the tank section 16 by opening the bubble door 24 and tipping the tank 14. Once all the refuse contained in tank section 16 had been discharged, the tank 14 would be lowered and the vehicle 10 could be driven to another site where the bubble door 24 and the door 25 would be opened together and the tank 14 tipped again to discharge the contents of the tank section 15. As an alternative to tipping, a travelling floor can be used for discharge purposes.

30 In the illustrated embodiment, co-mingled recyclables would be stored in the tank section 15 and other garbage would be stored in the tank section 16.

5 The embodiment of Figures 1 to 3 involves a bin having
a compartment 27 above a compartment 28 as the bin is being
emptied, the position of the blade 22 and the relative
positions of compartments 27 and 28 of the bin 20 are set
10 according to a predetermined geometry in order to maintain
separation of the refuse from the compartments. Thus, the
spatial relationship and geometry is such that a major
proportion of the contents of compartment 27 is deposited
on the far side of the blade 22 while the contents of the
15 compartment 28 and a major proportion thereof would be
deposited on the near side of the blade 22.

Although an open fall of material from the
compartments works to some degree, the inclusion of small
diversion plates or ramps or other elements in the transfer
20 mechanism is also envisaged to improve the geometry and
this will be discussed below.

While the embodiments illustrated so far utilise two
tank sections and a refuse transfer mechanism in the form
of a compaction device, the refuse transfer mechanism can
25 include a secondary or auxiliary transfer mechanism
operating in conjunction with the compaction device to
ensure a more reliable separation of the contents of the
compartments 27 and 28 of the bin 20 as the contents of the
bin flows into the hopper. Examples will be illustrated
30 below.

Figures 4 and 5 illustrate a further embodiment
employing an auxiliary refuse transfer mechanism which in
this case is a pivoting ramp 29 which moves to a position
35 illustrated in Figure 5 being aligned with the partition 21
of the bin 20. Ramp 29 is timed to move to its aligned
position with the partition 21 just after a jet of water
shown at 30 fired from nozzle 31 on the loading mechanism
19 opens the lid 32 of the bin 20 prior to the contents of
the bin 20 being discharged. This will be slightly delayed
due to the inertia of the bin being raised through its arc
of movement to the final stop position illustrated in
Figure 5. In other words, the combined effect of the

movement of the bin through its arc followed by the jet of water discharged from the nozzle 31 followed by raising of the ramp into the aligned position illustrated in Figure 5 will ensure that minimal recyclables from compartment 27 end up in the wrong tank section. As an alternative to the jet of water, other mechanically equivalent contrivances can be employed including air jets or directly acting mechanical lid openers.

As can be seen in Figures 4 and 5, a hydraulic, pneumatic, electric or other cylinder assembly 33 is employed to move the ramp 29 into position.

In another embodiment, the ramp 29 can be arranged to be moved into position illustrated in phantom at 34 so that all of the contents of the bin 20 will be transferred to tank section 16. This situation may arise in communities where some householders choose not to recycle. In these circumstances, each bin 20 would be provided with some form of indicator or signal operable by the householder to indicate whether or not the bin was a multi-compartment bin or a single compartment bin or whether it was full of garbage without any recyclables. The driver of the vehicle on seeing the signal would operate controls to retract the ramp 29 to the position illustrated at 34 for those bins which do not contain recyclable material and the full contents of the bin would travel through into tank section 16 which, as mentioned above, in this embodiment is devoted to non-recyclables. Where a multi compartment bin having correctly filled compartments is to be emptied, ramp 29 would be operated as shown in Figure 5.

The embodiment of Figures 1 to 5 illustrates a two tank section vehicle. An alternative to this is a vehicle for use with a triple compartment bin. This embodiment is illustrated in Figure 6. As can be seen, there is illustrated a vehicle 35 where the storage tank in this embodiment has three tank sections comprising a side tank section 36, a lower tank section 37 and an upper tank section 38 for separate storage of refuse delivered into a

hopper 40. The hopper 40 includes a loading aperture 41 which in this case is adjacent a side of the vehicle so that the refuse vehicle 35 operates as a side loading refuse vehicle.

5 A loading mechanism (not shown) as in the previous embodiment is used to empty the contents of a triple-compartment bin 43 (see Figure 7) into the hopper 40 through the aperture 41 and a refuse transfer mechanism 42 selectively diverts refuse delivered from the triple-
10 compartment bin into the respective tank sections 36, 37 and 38. In the illustrated embodiment, three types of refuse are shown and these are illustrated by the dots, squares and triangular shapes in order to show how the separation occurs.

15 As can be seen from Figures 6 to 10, a refuse bin 43 for use with the vehicle 35 includes three compartments 44, 45 and 46 which contain separately the different kinds of refuse which typically have been separated by a householder.

20 Thus, the respective types of refuse when delivered into the hopper 40 travel through the refuse transfer mechanism 42 into the respective tank sections.

As can be seen and also in Figure 6, an oscillating blade 47 sweeps through a semi-circular sub-hopper 48 which
25 is located below a sub-hopper 49 through which an elevator 50 travels to raise refuse in the sub-hopper 49 up onto an endless belt 51 which conveys refuse to the rear of the tank section 38. This brings about a degree of even distribution and compaction in the tank section 38.

30 In the illustrated embodiment, the oscillating blade 47 has an upper spill plate 52 which overlays a quadrant of the lower sub-hopper 48 and progressively opens and closes the adjacent quadrants of the sub-hopper 48. Refuse
35 initially delivered onto the plate 52 is above the sub-hopper 48 (see Figure 9) until the blade 47 moves through its stroke in the direction of tank section 37 where the plate begins to move to the other quadrant and the refuse

spills into the sub-hopper 48. The operation of this section of the transfer mechanism will be described in more detail below.

5 In the illustrated embodiment, the storage tank 36 includes an arcuate side walls 53 defining a generally square but medially bulged shape in section and the interior of the tank 36 is divided by a vertical partition 54 and a horizontal partition 55 defining the respective tank sections 36, 37 and 38. The tank section 36 is 10 generally L-shaped by virtue of the extension provided by the bubble door 56 which is shown open in Figure 6, and in the illustrated embodiment, the tank section 36 can be raised using a hoist in order to discharge refuse through the open door.

15 Once refuse has been discharged from tank section 36, internal doors 57 and 58 can be opened sequentially to discharge the contents thereof using a similar tipping action.

20 It will be appreciated from the foregoing therefore that refuse vehicle 35 will take about half refuse in tank section 36 which in most cases would be normal disposable refuse whereas tank sections 37 and 38 can be used to accommodate two different forms of recyclables. For example, paper could well be stored in tank section 38 25 while co-mingled glass, plastic bottles and cans could well be stored in tank section 37.

30 It will be noted that in Figure 6, when compared to Figures 7 to 10, part of the sub-hopper 49 has been omitted to expose the blade 47 and the plate 52 for clarity purposes. The operation of the refuse transfer mechanism will become clearer from the following description.

35 Referring now to Figures 7 to 10, there is illustrated in more detail the refuse transfer mechanism 42 including its operation and where appropriate, like numerals have been used to illustrate like features. The only difference is that in Figures 7 to 10, moveable chute 59 has been included in the drawings whereas this moveable chute has

been omitted in Figure 6 but it being understood that the moveable chute forms part of the embodiment illustrated in Figure 6.

Referring to Figures 7 to 10, there is illustrated initially in Figure 7 a bin 43 engaged on the loading mechanism 19 just prior to an emptying operation being invoked. Figures 8, 9 and 10 show the various stages during which the bin 43 is emptied into the hopper 40. The transfer mechanism in this case includes a moveable ramp 59 including first and second ramp sections 60 and 61 which take the contents of compartments 46 and 45 respectively.

As the bin 43 is inverted above the aperture 41 to the position illustrated in Figures 9 and 10 (Figure 10 in phantom), the ramp 59 is moved into the position illustrated in Figure 9 shortly after a waterjet or airjet via nozzle 62 has been delivered to the lid 63 so that the lid and ramp will not collide.

At this stage, the oscillating paddle 47 is shown half way through its stroke toward tank section 37. The contents of compartment 46 will flow directly into the sub-hopper 48 on the tank section 37 side and be swept by blade 47 into the tank section 37. At the same time, the contents of compartment 44 of the bin 43 will have been deposited onto the quadrant spill plate 52 as illustrated in Figure 9 and as the blade 47 sweeps towards tank section 37, the sub-hopper 48 on the tank section 36 side thereof will open and the refuse on top of the plate 52 will be pushed off into the sub-hopper 48 on the rearward side of the blade 47 by central fixed scraper 64.

Thus, during the return stroke of the blade 47, lost motion will be experienced between the blade 47 and plate 52 for 90° of the blades travel and the sub-hopper on the tank section 37 side will remain closed. Refuse from compartment 44 which fell off the plate 52 will be transferred into tank section 36 as the blade 47 sweeps towards that tank section. As this happens, refuse will spill into the tank section 37 side of the sub-hopper 48.

The contents of compartment 45 will travel down the ramp section 61 into the sub-hopper 49 and as the sub-hopper 49 fills, operation of the elevator 50 will raise refuse up and deposit same on to the endless conveyor 51 which will move the refuse rearwardly in the tank section 38.

It will be appreciated that a bin can be emptied at any time and depending on the position of the blade 47, as a bin is emptied the contents of the compartments will always reach the right tank section.

Referring to Figure 11, there is illustrated another vehicle according to the invention. In this case, the vehicle does not include the bubble door of the previous embodiments, but can do so.

The vehicle in this case has a partition 65 defining upper and lower storage regions which partition slopes toward a forward end 66 of tank section 67 so that material such as glass will vibrate forward in an upper storage region 68 and gradually fill from the rearward end 69 toward the forward end 66.

The embodiment of Figure 11 includes two doors, an outer door 70 which extends the full length and width of the vehicle while a second door 71 to storage region 68 is located inside the door 70.

The vehicle includes an entrance 72 adjacent the forward end 66 of the tank section 67. The entrance communicates with respective upper and lower material transfer mechanisms which in this case comprises a conveyor assembly 73 and an oscillating compactor blade assembly shown generally at 74. This compactor blade assembly is the same as in the previous embodiments except the spill plate is omitted.

Referring now to Figures 12 and 13, there is illustrated a refuse vehicle 75 for use with a multi-compartment bin having side-by-side compartments. In this case, the vehicle is a side loading refuse vehicle having a wheel assembly 76 supporting a cab 78 and a chassis 79.

A storage tank 80 is mounted on the chassis, a hopper 81 communicates with the tank 80. The hopper has a loading aperture 82 adjacent a side of the vehicle 75 and a loading mechanism 83 is adjacent the hopper. The hopper is adapted to receive refuse from a bin 84 during a loading operation and a typical loading operation is illustrated in Figures 12 and 13.

As in the previous embodiments, the tank section 80 includes two tank sections. A refuse transfer mechanism is employed to move refuse delivered into the hopper into the tank 80 and in the illustrated embodiment includes a refuse separator means in the form of a divider plate 85, the leading edge 86 of which aligns and abuts against or is closely spaced from an upper edge 87 of a partition 88 in the bin 84. The partition 88 divides the bin 84 into two side-by-side compartments and as will be appreciated from the foregoing description, when the bin 84 is inverted over the hopper as illustrated in Figure 13, the contents of the respective compartments are maintained separate by virtue of the divider plate 85 being in place.

As can be seen in Figure 12, the bin 84 includes a lid 89 which is illustrated in the position shown in Figure 12 so that a slot 90 in the lid can be seen in the drawing. This slot 90 enables the lid to straddle the divider plate 85 and therefore the divider plate 85 does not interfere with operation of the lid 89.

Referring to Figures 14 and 15, there is illustrated in more detail internal operation and construction of the vehicle 75. Where appropriate, like numerals have been used to illustrate like features. As can be seen, the plate 85 defines a side wall of a chute 91 along which refuse delivered into the hopper flows to a sub-hopper 92 which feeds an elevator 93. The elevator in turn feeds a conveyor 94, the conveyor and elevator deliver refuse into the tank section atop a partition 95 while other refuse free falls into a lower hopper section 96 where an oscillating blade 97 sweeps refuse into a lower tank

section 98 below the partition 95. The upper tank section 99 typically carries commingled recyclables in the form of plastic bottles and cans while the lower tank section 98 typically carries other domestic garbage.

5 As can be seen in Figure 14, the lid 89 of the bin 84 swings freely by virtue of the slot 90 enabling passage of the divider plate 85. As a consequence of the slot 90 not extending the full width of the lid 89, the plate 85 includes a cut-out portion at 100 to accommodate for this
10 feature.

As can be seen in Figure 15, the bin 84 can be slightly out of position on the loading mechanism and for this reason, respective lead-in guides 101 and 102 are employed and these will be described in more detail in
15 relation to Figures 16 and 17.

Referring to Figure 16, there is illustrated the basic configuration of the lead-in guides 101 and 102 relative to the divider plate 85 and the leading edge 86 thereof. As can be seen, the lead-in guides 101 and 102 comprise
20 convergent plates which include bin abutment flange members 103 and 104. It will therefore be appreciated by virtue of the lead-in guides 101 and 102 and the position of the edge 86 that a bin loaded on to the flange members 103 and 104 will be suitably positioned so that the divider plate 85
25 serves its purpose for maintaining the refuse in the respective compartments of a bin separate as they are delivered into the hopper.

The embodiment of Figure 17 is slightly different to that of Figure 16 inasfar as this arrangement applies to a
30 three tank section vehicle and to a three compartment bin having partitions defining a T-shaped upper edge similar to the bin 43 (see Figure 7) and as can be seen in this case, a second ramp 105 is made available for refuse in the third compartment. In all other respects, the hopper is the same
35 as for the previous embodiments.

Referring now to Figure 18, there is illustrated an alternative embodiment of a bin 106 where in this case a

partition 107 extends as shown. In this case, the bin includes two lids 108 and 109 which swing open so the partition 107 engages with or becomes closely spaced from a moveable ramp 110. The contents of the bin flows to either side of an oscillating paddle 111 to be swept alternately into respective tank sections 112 and 113 defined either side of a vertical partition 114. The ramp 110 can be retracted to the position shown at 115 in the event of a contaminated bin being observed by the driver of the refuse vehicle so that all the contents of the bin can ultimately be delivered into the tank section 113.

The previous embodiments have illustrated the use of various transfer mechanisms including compacters and conveyors. Another form of conveyor that can be employed in a transfer mechanism is a travelling floor that can extend from say a sub-hopper right back or part way along one or more of the tank sections. Referring now to Figure 19, a typical tank 116 is illustrated and as can be seen, the tank has a section which can be described as a medially bulged square shape which results in arcuate corner regions at 117 and 118. The travelling floor in this case includes a plurality of plates 119 arranged so the travelling floor is arcuate in shape to match the shape of the tank 116.

Referring to Figure 20, there is illustrated the form of the travelling floor which comprises a base 120 having a plurality of rails 121 on which are mounted self-lubricating plastics bearing members 122. The plates 119 are in the form of contiguous inverted channel members so that the plates 119 can reciprocate back and forth on the bearings 122 on the rails 121 in sealed relation.

Operation of a typical travelling floor is illustrated in Figure 21 and where appropriate, like numerals have been used to illustrate like features. As can be seen, pairs of cylinder assemblies 123 and 124 are disposed at opposite ends of piston rods 125, each of which are connected to respective drive arms 126, 127 and 128. The drive arms 126, 127 and 128 are arcuate and have offset mounting bars

129 which are coupled to groups of the plates 119.

The resultant action upon controlled operation of the cylinder assemblies is that the plates 119 are all driven in unison in the discharge direction to move refuse into the tank section but are selectively retracted in the upstream direction so that the load being conveyed is not retracted with the individual plates 119. Usually every third plate 119 is retracted initially followed by every alternate remaining plate and then the final plates are retracted before all plates are driven on a downstream stroke once again to shift the load. Thus, the plates normally reciprocate over a range of about 12 inches as the cylinder assemblies 123 and 124 operate in predetermined sequence.

The travelling floor can be used in any tank section as the transfer mechanism or can be used in conjunction with any of the previous described transfer mechanisms.

Referring now to Figures 22 and 23, there is illustrated a further embodiment, and where appropriate, like numerals have been used to illustrate like features. As can be seen, the only difference between the embodiments of Figures 3 and 4 and that of the earlier embodiments is that the loading mechanism 19 in this case is located at the end of a retractable arm assembly 130. The loading mechanism 19 can be extended transversely of the vehicle to engage a bin and then the loading mechanism 19 can be retracted to a position adjacent the hopper 17 wherein the bin can be tipped to the position illustrated in Figure 23 so its contents can be discharged into the hopper 17. In this embodiment, operation of the loading mechanism, insofar as engaging a bin 20, is controlled from the vehicle cab 12 whereas in the embodiment of Figures 1 and 2, the loading mechanism 19 is fixed adjacent the hopper and the bin 20 must be placed in position by an operator. The retractable arm assembly or its mechanical equivalent can be used with any of the previous embodiments.

Whilst the above has been given by way of illustrative

example of the present invention, many variations and modifications thereto will be apparent to those skilled in the art without departing from the broad ambit and scope of the invention as set forth in the appended claims.

CLAIMS

1. In a side loading refuse vehicle, the combination of an elongate refuse storage tank divided into longitudinally extending tank sections, a loading mechanism adjacent a side of the refuse vehicle and a refuse transfer mechanism for delivering refuse or other material emptied into the vehicle by the loading mechanism to the respective tank sections.
2. The combination of claim 1 wherein the transfer mechanism comprises a hopper and an oscillating blade in the hopper being adapted to sweep through the hopper to alternately sweep refuse or other material delivered into the hopper by the loading mechanism to one side and then to another side of the hopper as the blade oscillates back and forth within the hopper, the transfer mechanism having a moveable hopper closure means to partially close the hopper behind the blade so as to prevent material intended to be delivered to one side of the hopper being inadvertently delivered to the other side of the hopper as the blade travels through the hopper.
3. The combination of claim 1 wherein the storage tank of the refuse vehicle has two or three tank sections, and the transfer mechanism comprises a hopper communicating with the tank sections and means for selectively diverting refuse or other material delivered into the hopper by the loading mechanism to the respective tank sections.
4. The combination of claim 1 wherein the tank sections comprise upper and lower storage regions having respective forward and rearward ends and respective entrances adjacent the forward ends, the transfer mechanism comprising respective upper and lower transfer mechanisms for selectively diverting refuse or other material through the entrances to the respective upper and lower storage regions.
5. The combination of claim 1 wherein the transfer mechanism includes a refuse separator means adjacent the loading mechanism and adapted to be located in close

proximity to a bin inverted over the separator means by the loading mechanism for separating refuse delivered into the transfer mechanism so the separated refuse is moved to the respective tank sections.

6. The combination of claim 1 wherein the refuse vehicle includes a conveyor in one of the tank sections so that refuse can be conveyed along the tank sections, the conveyor being an endless belt conveyor or a travelling floor conveyor.

7. The combination according to any one of claims 1 to 6 including a bin releasably coupled to the loading mechanism, the bin having respective refuse storage compartments and the loading mechanism, bin and transfer mechanism being operatively associated one to another so that as the bin is emptied by the loading mechanism into the transfer mechanism, refuse is selectively transferred from the respective compartments of the bin into the respective tank sections.

8. The combination according to any one of claims 1 to 6 wherein the tank sections have respective discharge doors with one discharge door being operatively located outside the other discharge door so that the tank sections can be discharged sequentially.

9. The combination according to claim 1 or claim 3, claim 5 or claim 6, wherein the transfer mechanism includes a passive or active mechanism or a combination of passive and active mechanisms selected from the following:-

- (i) an automated bin lid opening device;
- (ii) a retractable refuse diversion chute or bin compartment alignment means;
- (iii) bin compartment alignment means which align with or abut against a compartment defining portion of a bin so that refuse from the bin remains separate as it flows from the bin, through the transfer mechanism and finally into the tank sections;
- (iv) a refuse compaction device;
- (v) a longitudinally moveable oscillating slide packer;

- (vi) a packer which includes an oscillating blade which oscillates about a substantially vertical axis relative to the longitudinal direction of the tank sections; or
- (vii) a travelling floor conveyor.
10. The combination according to claim 2 wherein the hopper is generally semi-circular in plan and the moveable hopper closure means comprises a refuse spill plate which forms a generally horizontal closure for a quadrant of the semi-circular hopper so that as the blade travels through the hopper, adjacent quadrants of the hopper are alternately and progressively closed and opened by the plate so that refuse is separated by being delivered into the hopper on top of the plate and then subsequently flowing to a position below the plate.
11. The combination of claim 10 wherein the blade travels back and forth through a 180° arc between tank section entrances at each end of the blade travel and each end of the travel of the blade is defined as a forward stroke, during the last 90° of travel toward a tank section entrance and travel of the blade is defined as a return stroke during the initial 90° of movement away from a tank section entrance after the forward stroke is completed, the relative motion of the blade and the plate involving lost motion between the blade and the plate during a major portion of the return stroke.
12. The combination according to claim 3 or claim 4 wherein the transfer mechanism employs an elevator to raise refuse to an upper tank section.
13. The combination according to claim 3 or claim 4 wherein a plurality of independent hopper regions are employed so that refuse from a multi-compartment bin can be selectively delivered into the hopper regions as the bin is emptied.
14. The combination of claim 13 wherein the transfer mechanism includes an elevator having upper and lower ends, the hopper regions include respective distal and proximal regions relative to the loading mechanism, the distal

and/or proximal regions being sub-divided into upper and lower regions which include a sub-hopper containing the lower end of the elevator.

15. The combination according to claim 3 wherein the transfer mechanism includes a mechanism selected from the following:-

- (i) an oscillating blade or plate;
- (ii) an endless belt; or
- (iii) a travelling floor.

16. The combination according to claim 4 wherein the upper storage region includes a sloping floor which slopes down toward the forward end of the upper storage region, the upper transfer mechanism includes so that as the vehicle travels, the sloping floor causes compaction of refuse toward the forward end of the upper storage region.

17. The combination according to claim 4 wherein the upper transfer mechanism comprises a conveyor assembly having an upwardly and rearwardly extending conveyor run for moving refuse from the entrance to the rearward end of the tank section.

18. The combination according to claim 7 wherein the lower transfer mechanism comprises a compactor assembly.

19. The combination according to claim 1 wherein the transfer mechanism includes means for receiving and selectively diverting refuse from a bin having two compartments which are side-by-side as the bin is emptied or a bin having two compartments one above the other as the bin is emptied so that refuse from the compartments is maintained separate as the refuse is moved to the respective tank sections.

20. The combination according to claim 1 or claim 19 wherein the vehicle includes a bin alignment means including a bin lead-in guide to take into account relative position of a bin on the loading mechanism, the lead-in guide being disposed to move the bin on the loading mechanism as it is emptied so that it is emptied according to a predetermined geometry relative to the transfer

mechanism.

21. The combination according to claim 1 wherein the transfer mechanism includes a refuse separator means that abuts or locates adjacent a bin partition located beneath a bin lid, the separator means not interfering with any automatic operation of the lid as the bin is emptied.

22. The combination according to claim 6 or claim 15 wherein the storage tank is arcuate in shape and the travelling floor is arcuate, at least in part to match the shape of the tank section.

23. The combination according to claim 1 wherein the transfer mechanism comprises a retractable means operable to prevent refuse being delivered to one of the tank sections.

24. The combination according to any one of claims 1 to 6, 19, 21 or 23 wherein the loading mechanism is coupled to the vehicle via a retractable arm assembly.

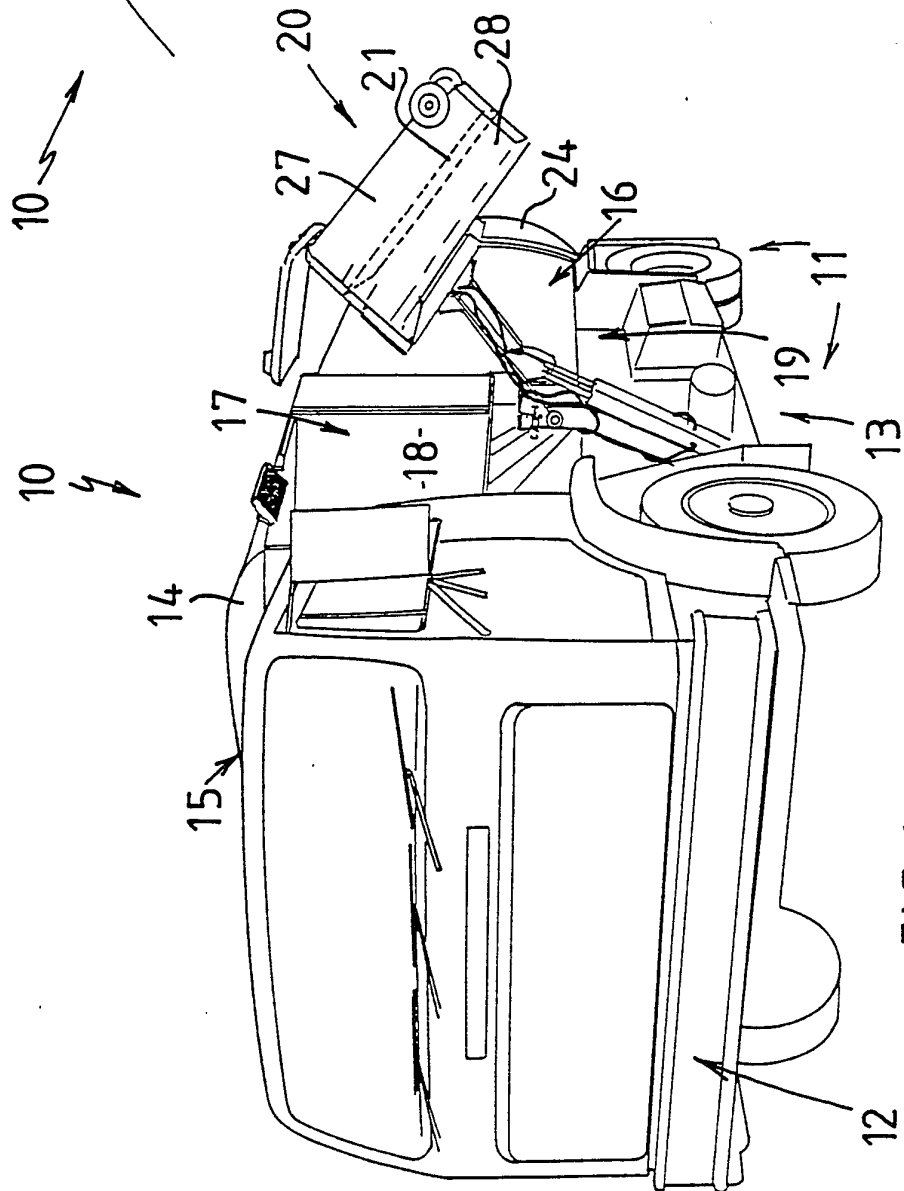
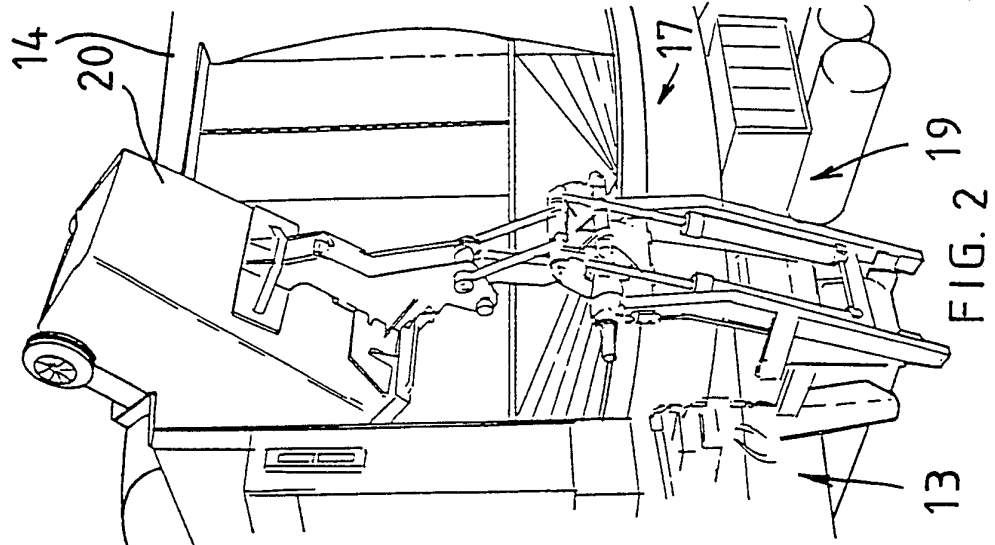

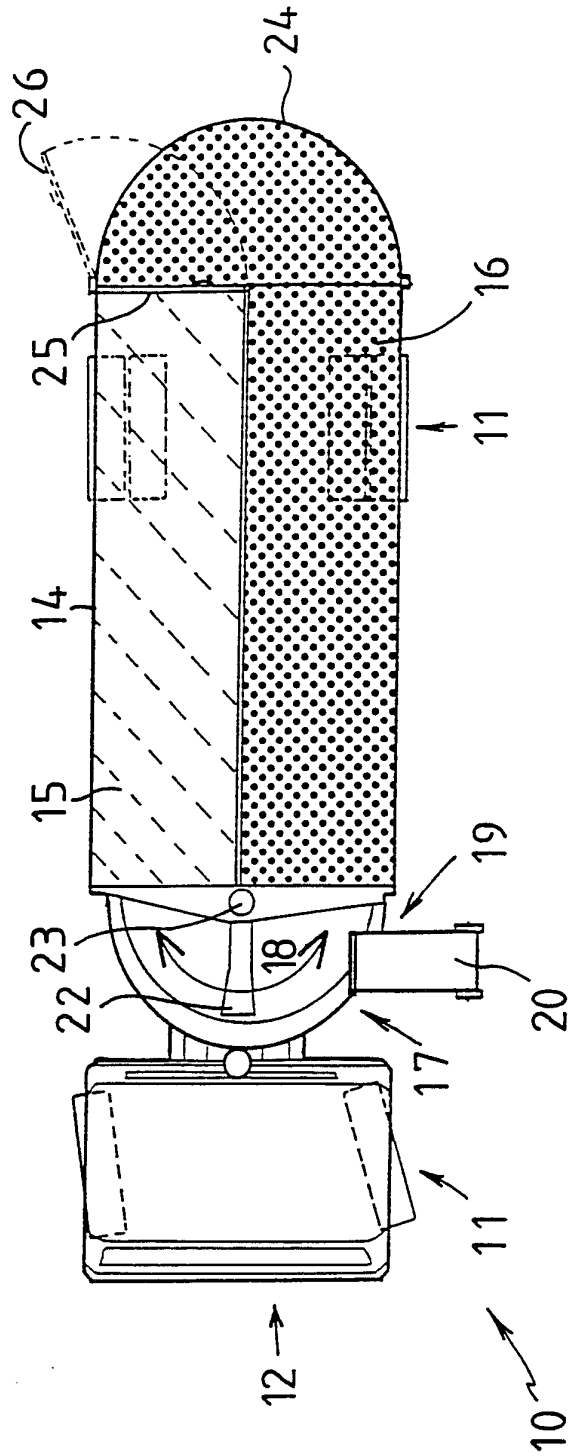

FIG. 3

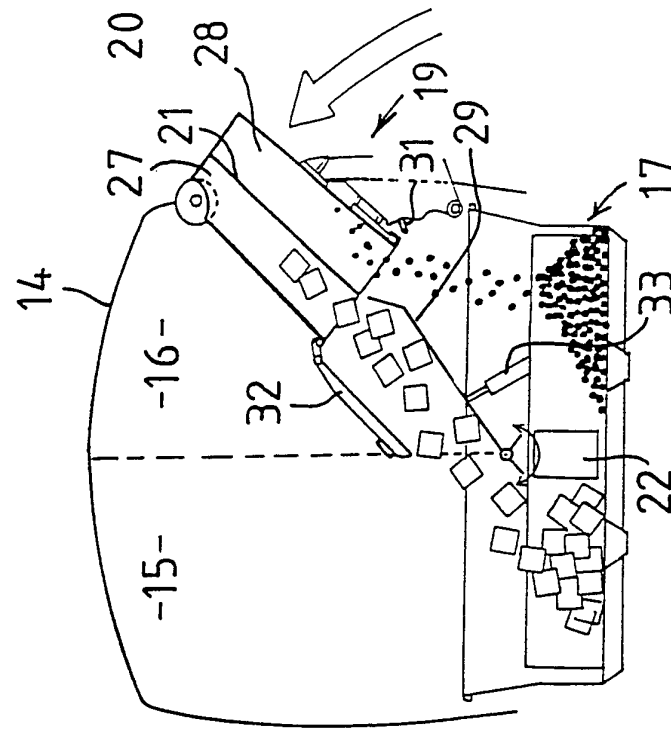

FIG. 5

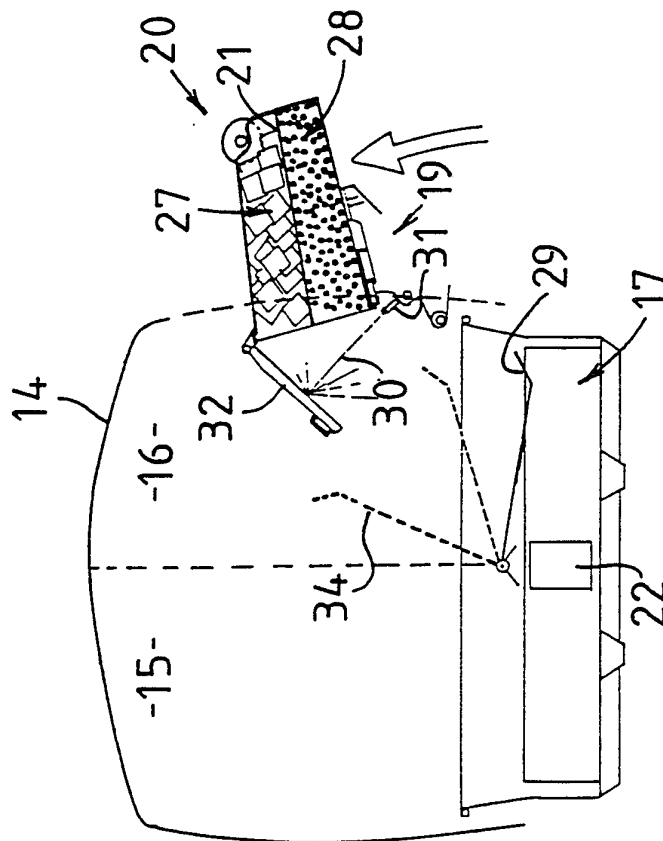

FIG. 4

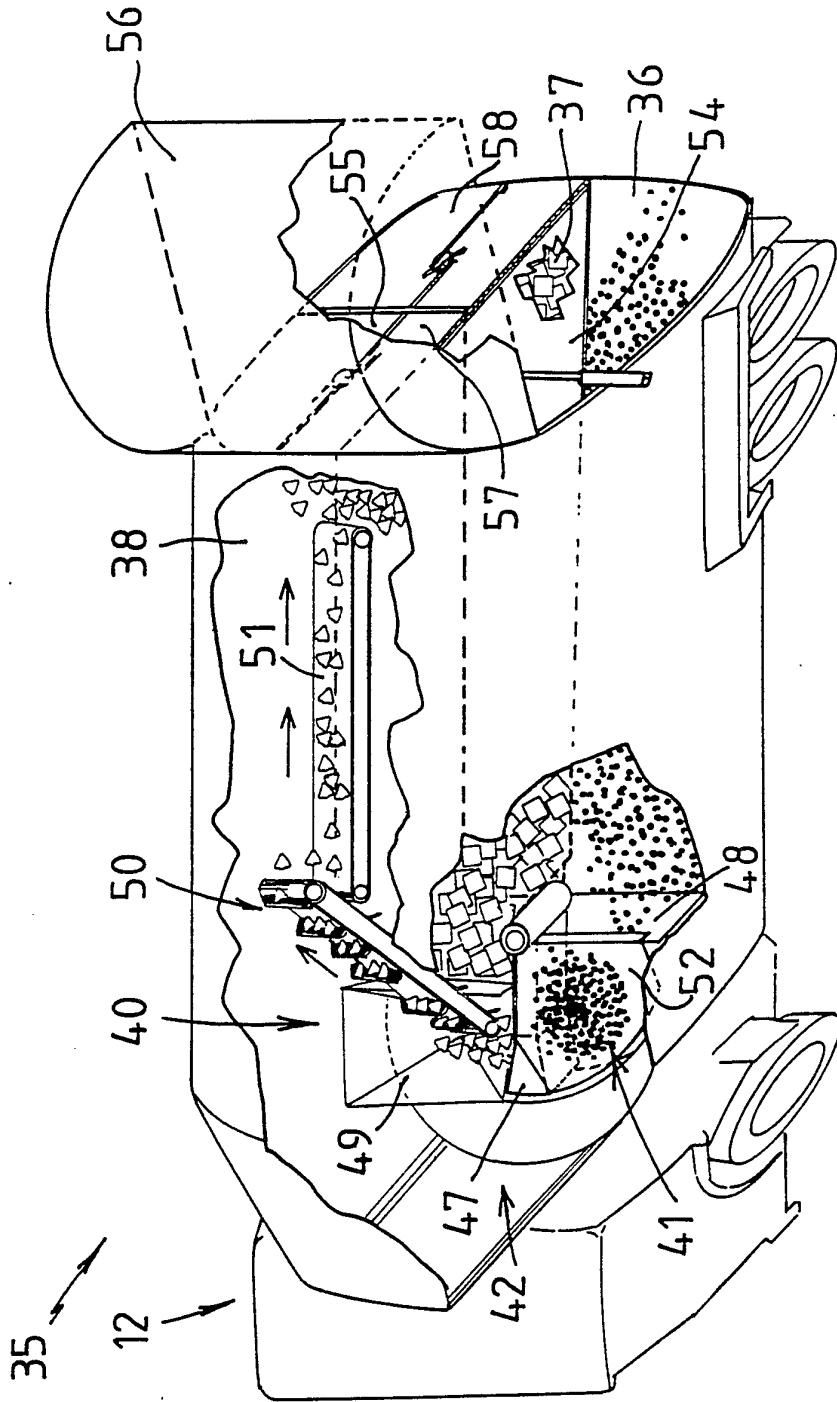

FIG. 6

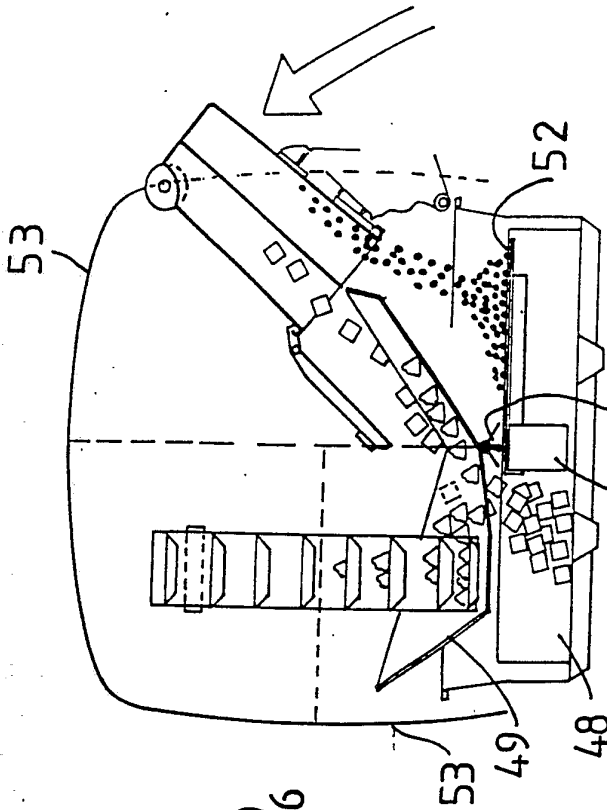

FIG. 9

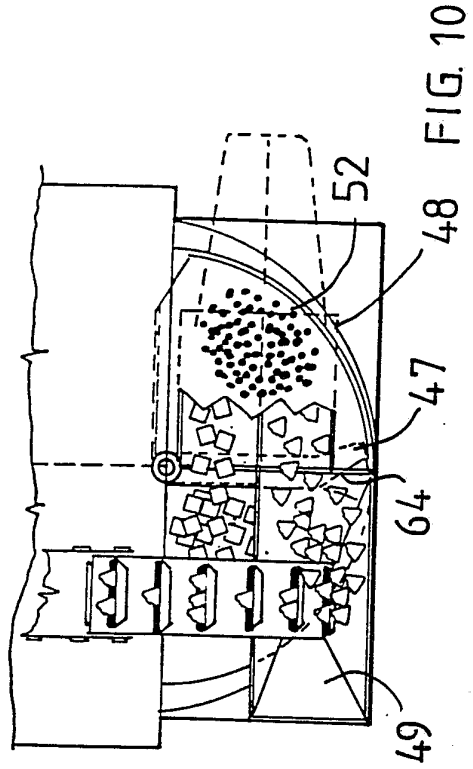

FIG. 10

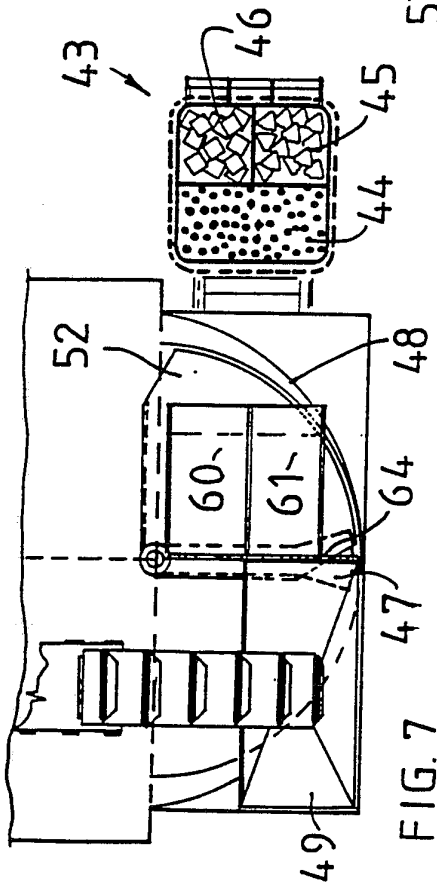

FIG. 7

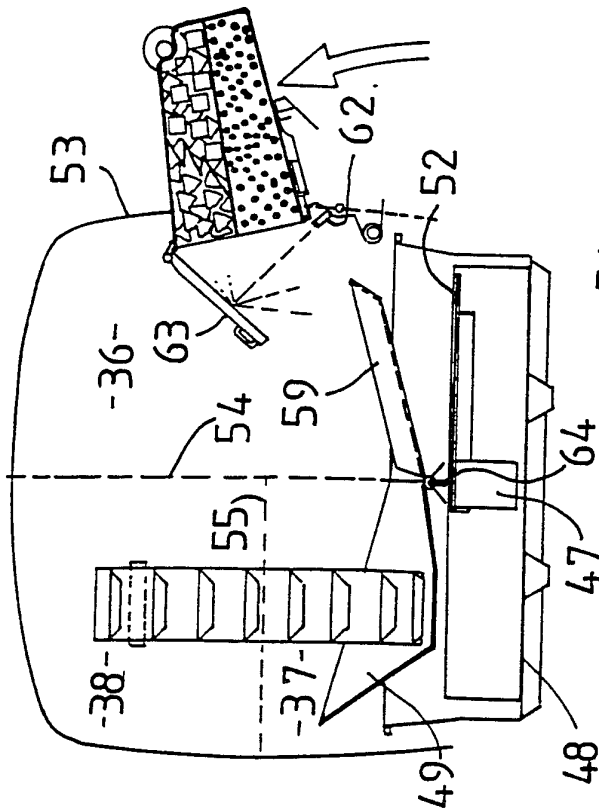

FIG. 8

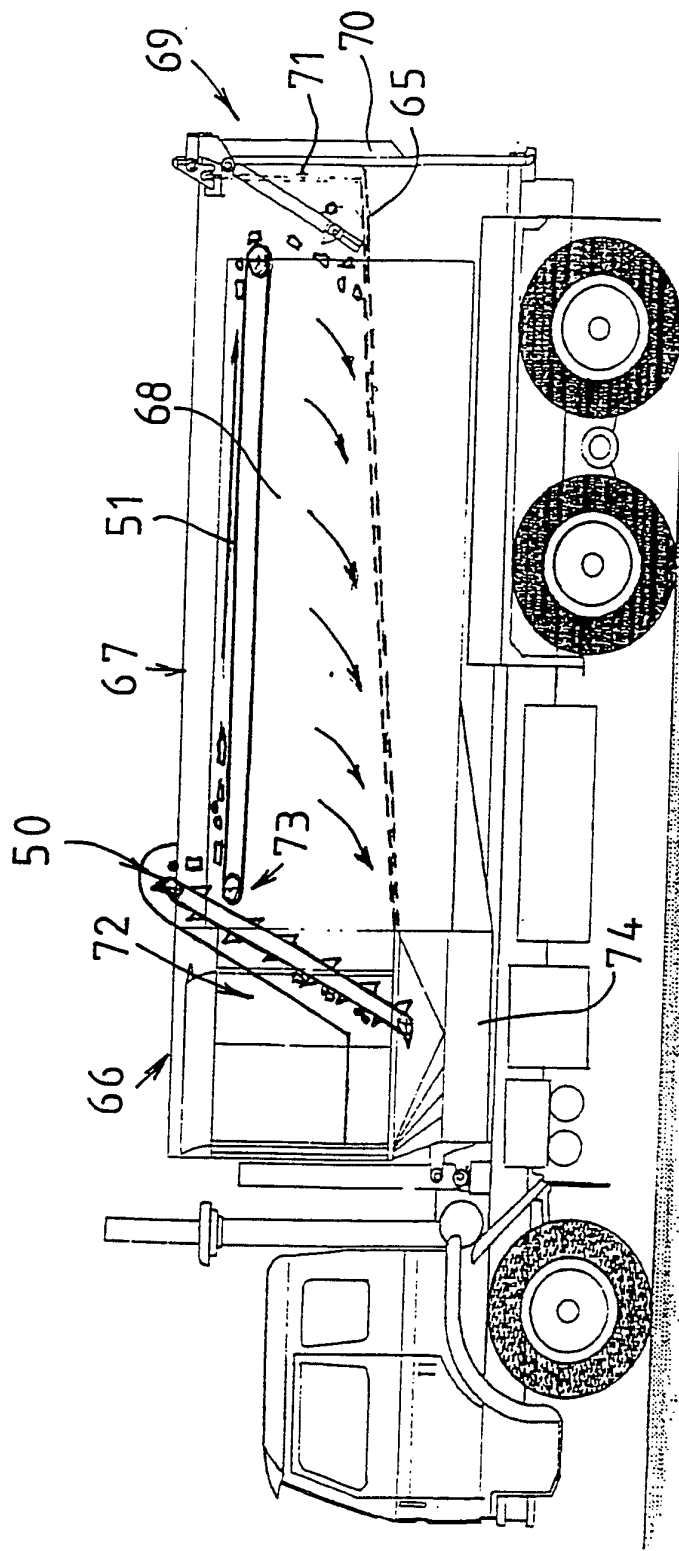

FIG. 11

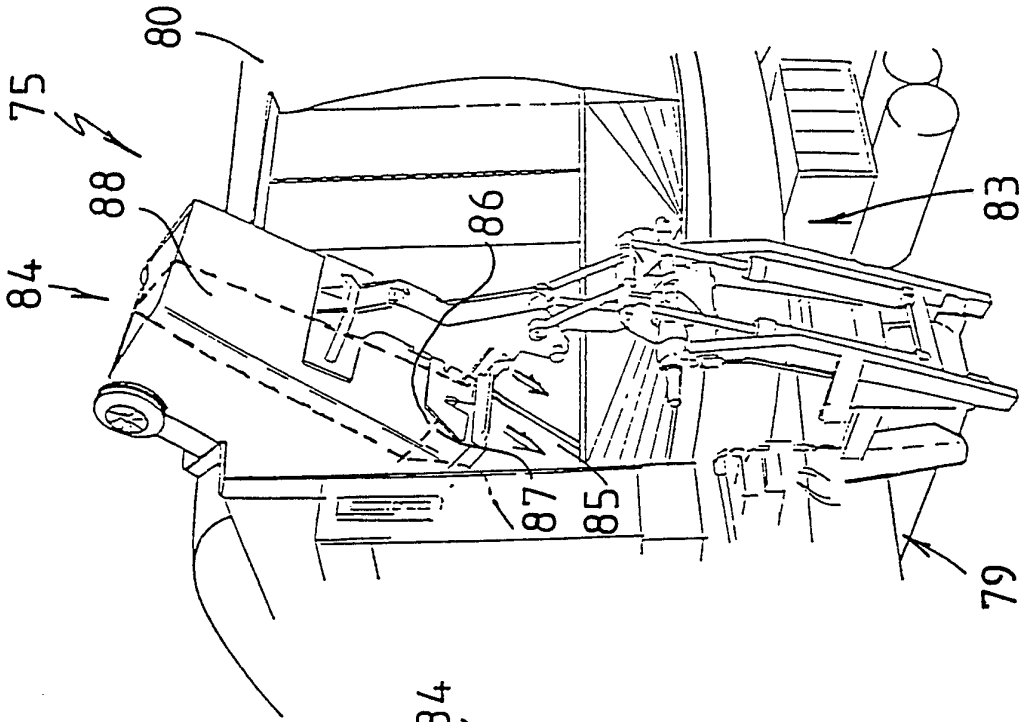

FIG. 13

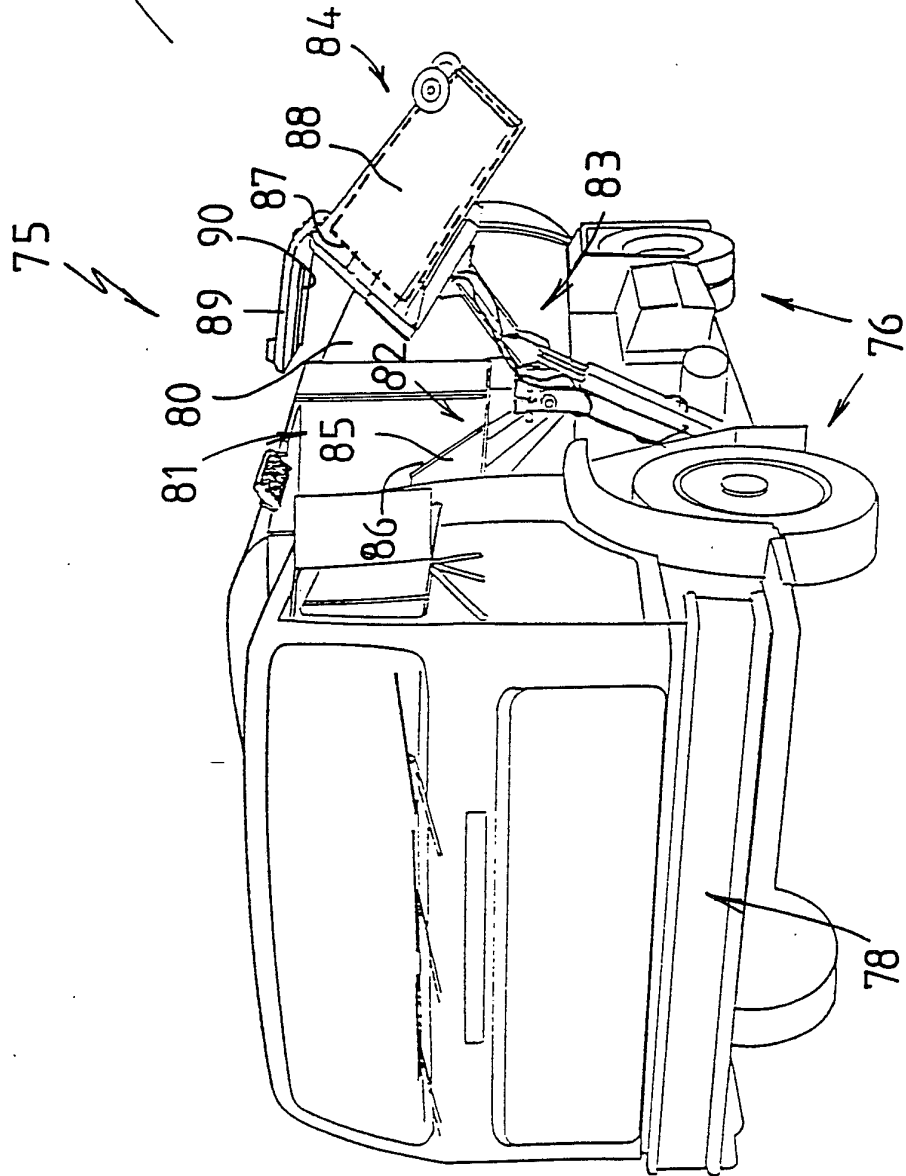

FIG. 12

8 / 13

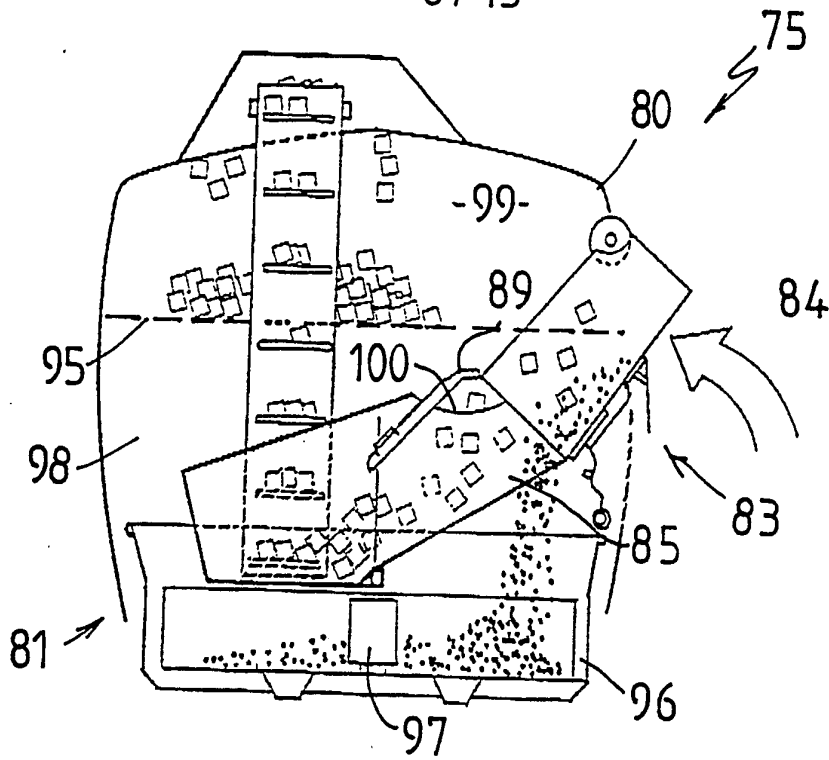

FIG. 14

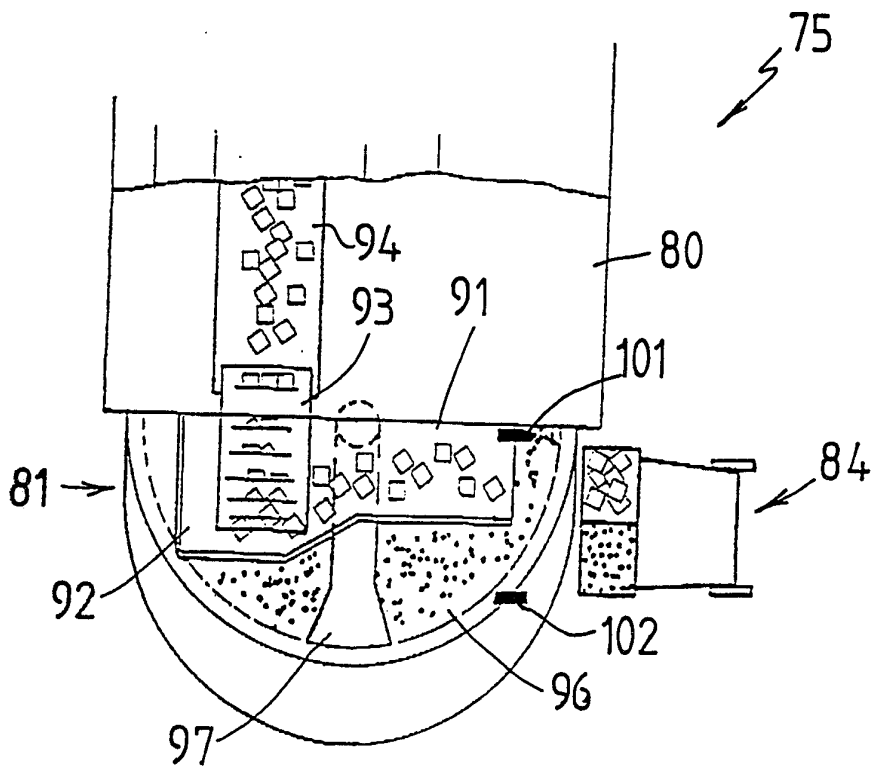

FIG. 15

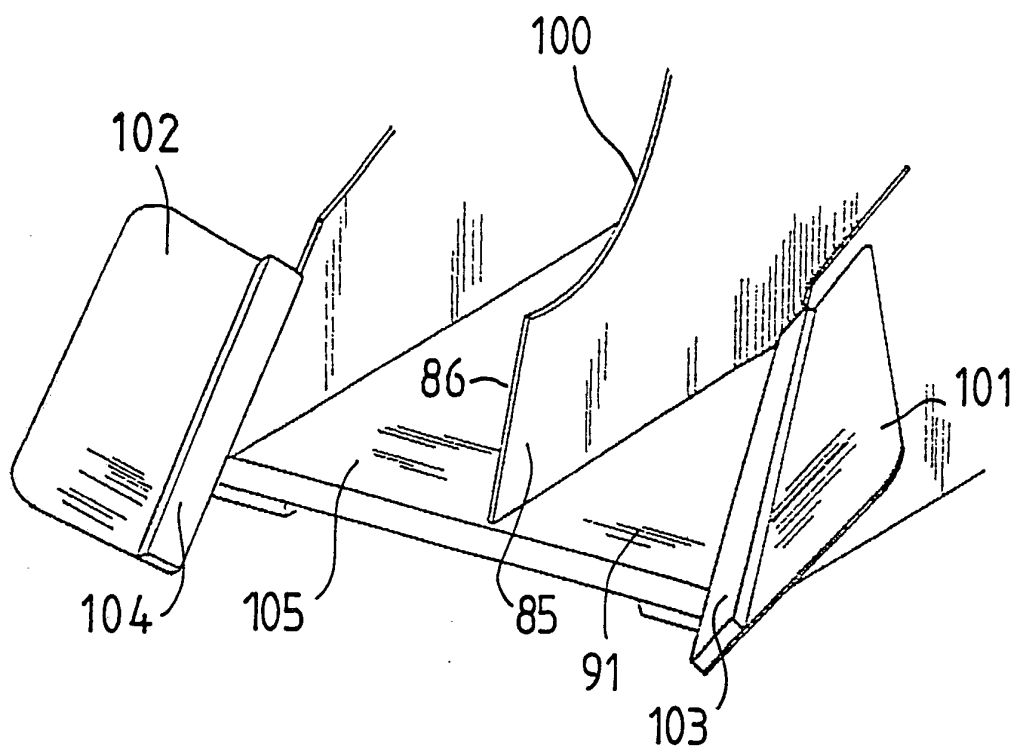

FIG. 16

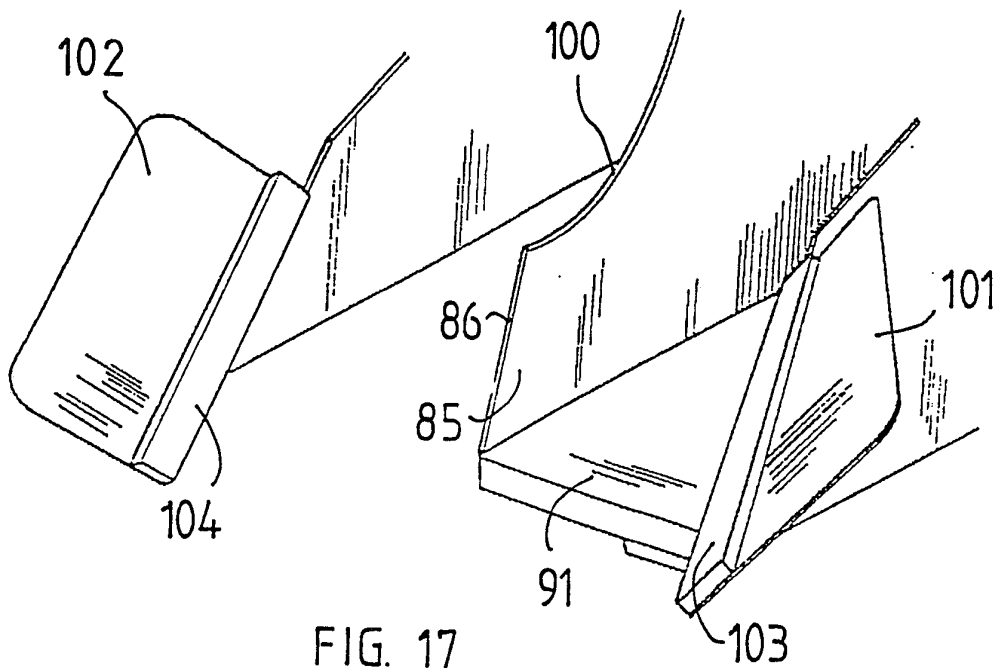

FIG. 17

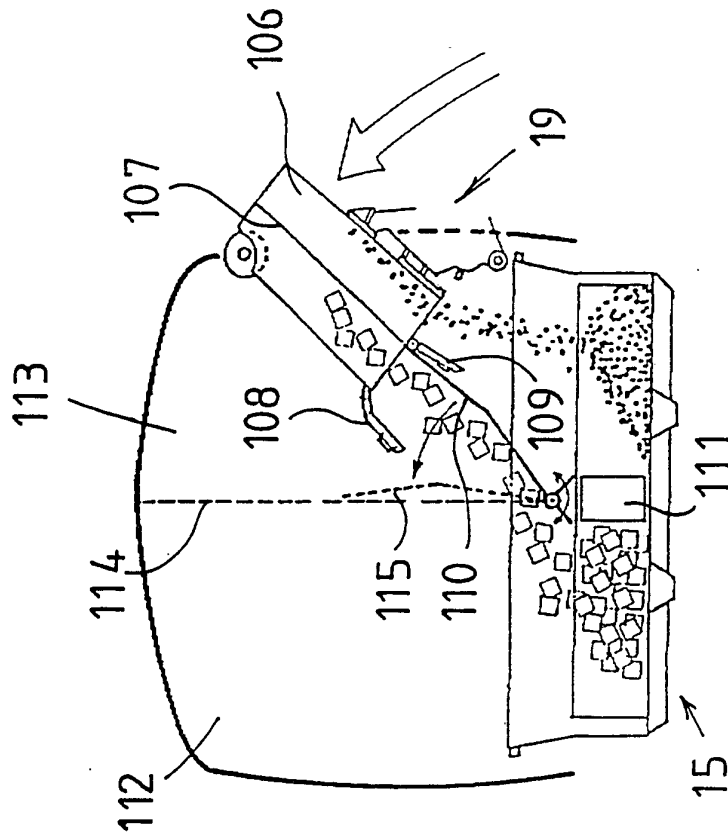
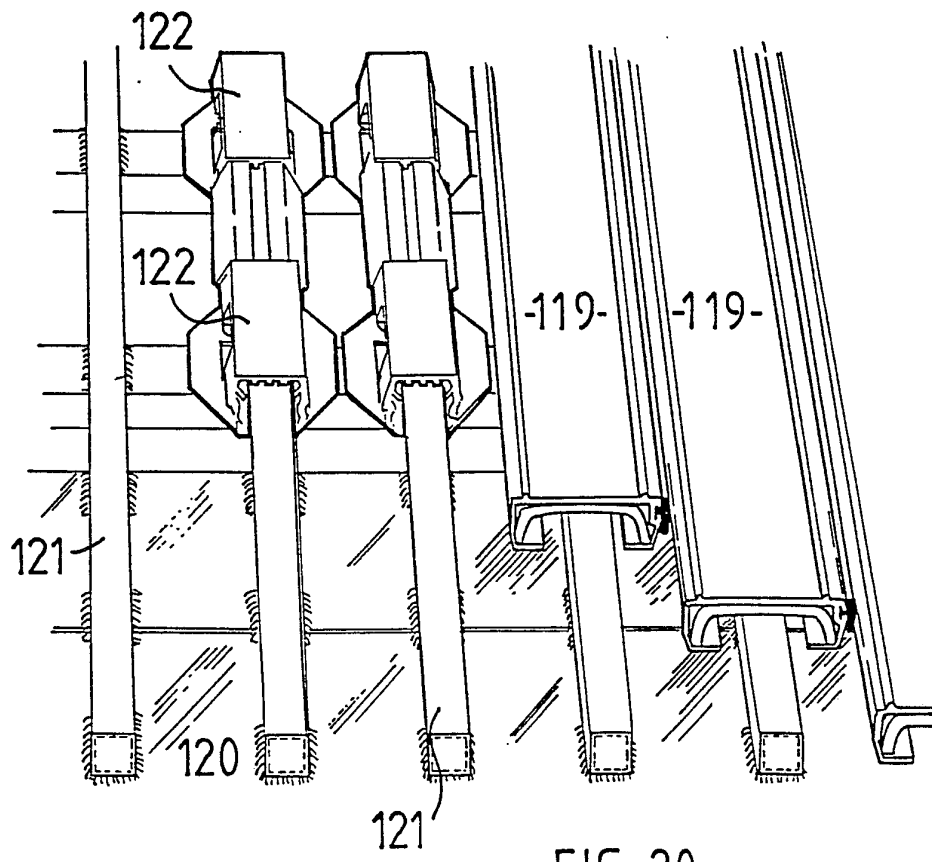
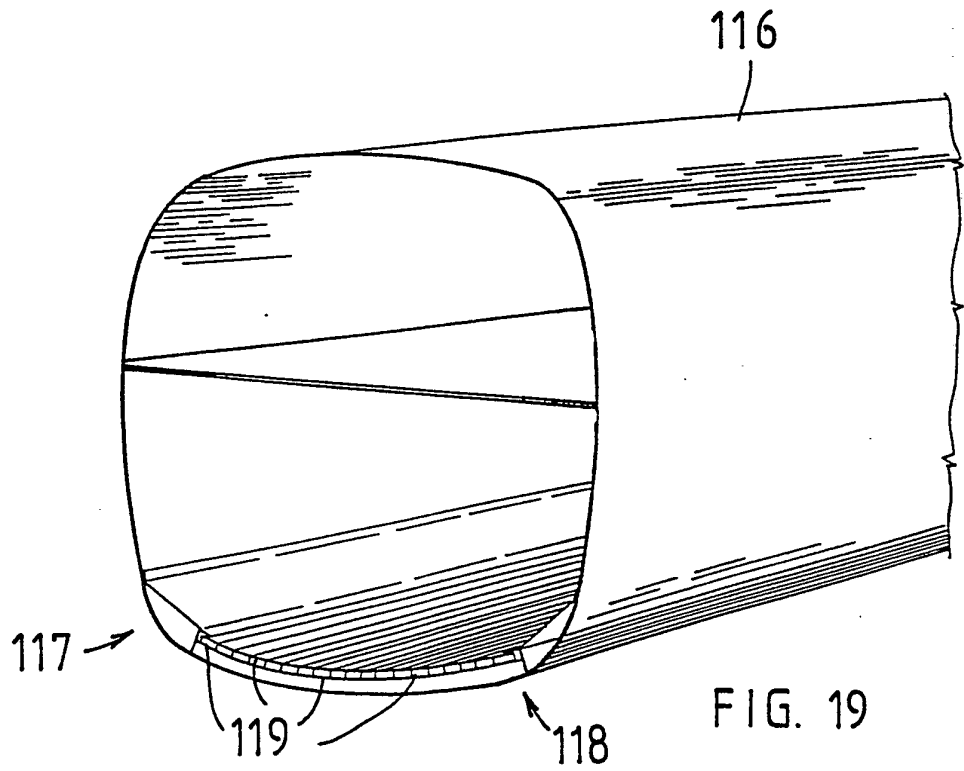

FIG. 18

11 / 13



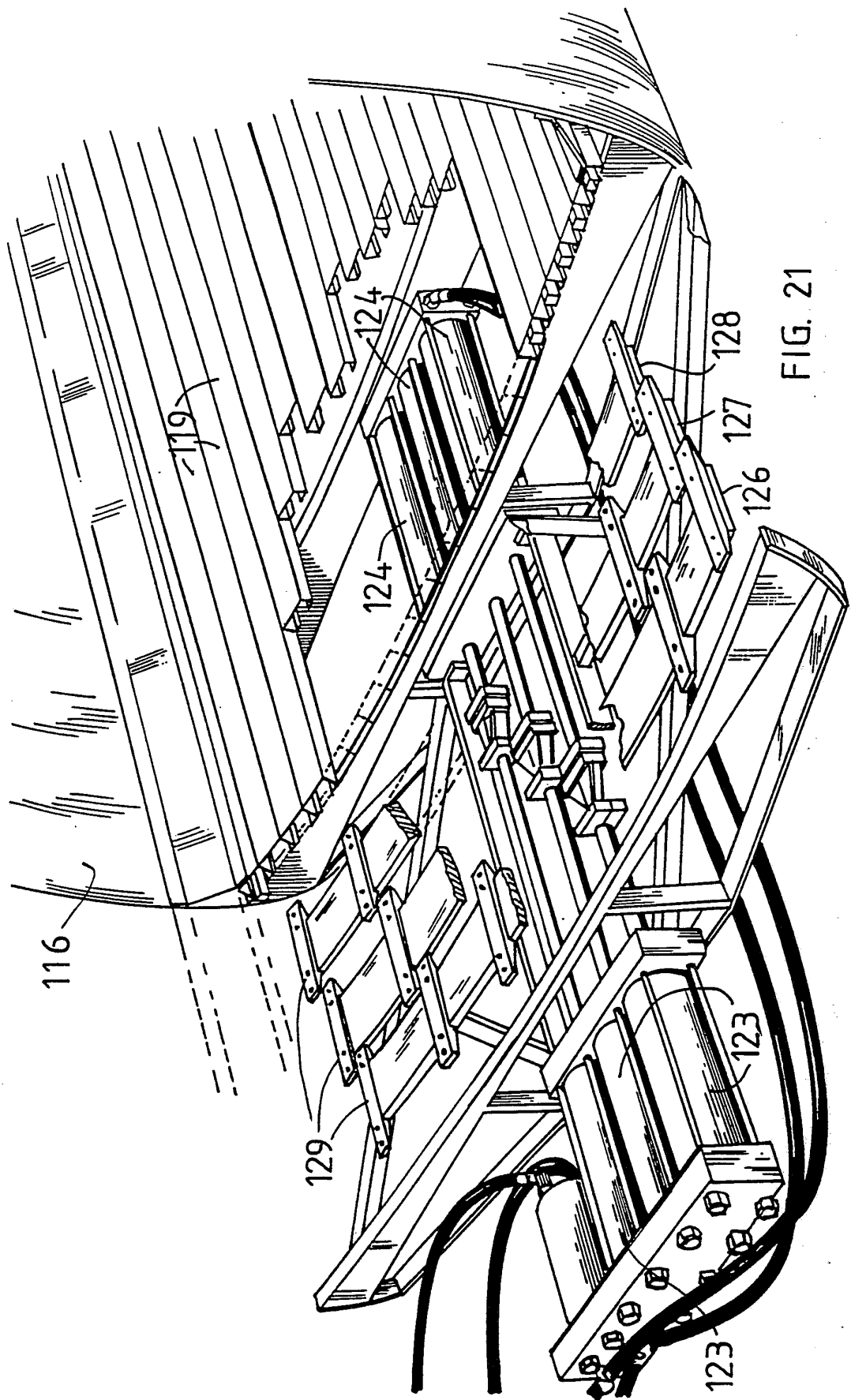

FIG. 21

13 / 13

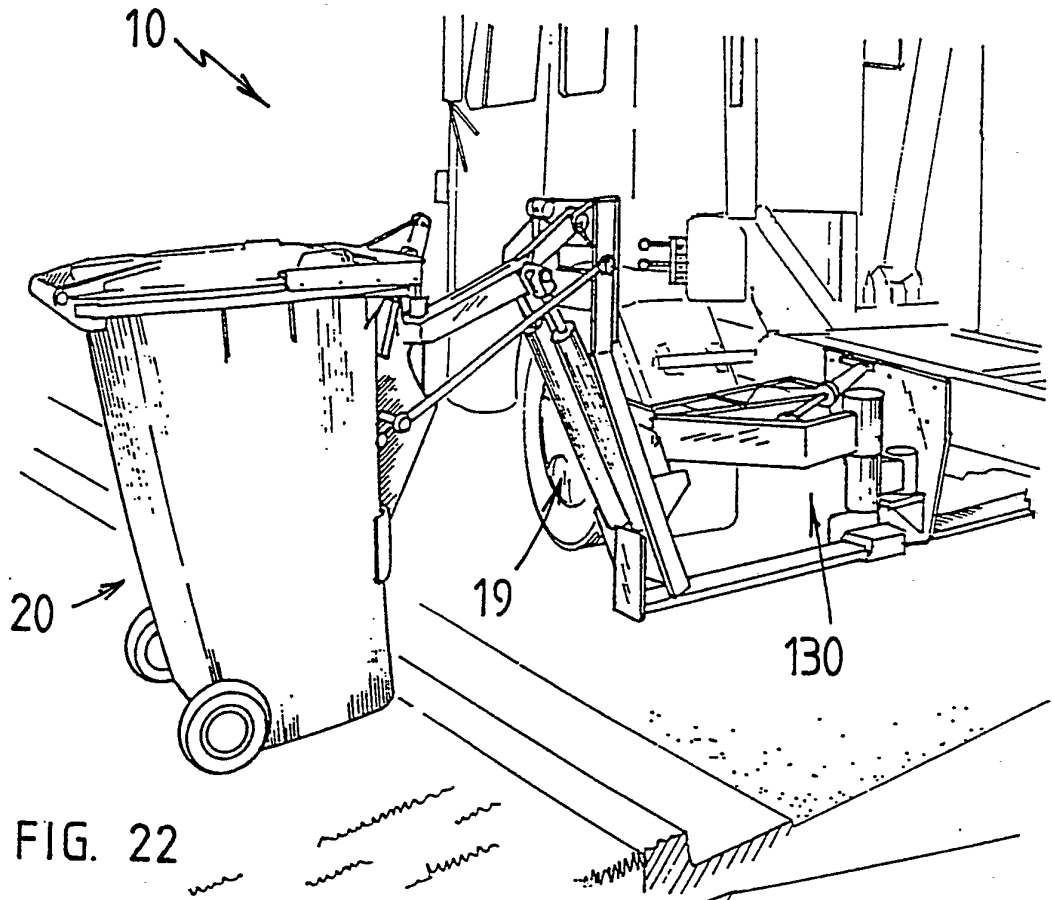

FIG. 22

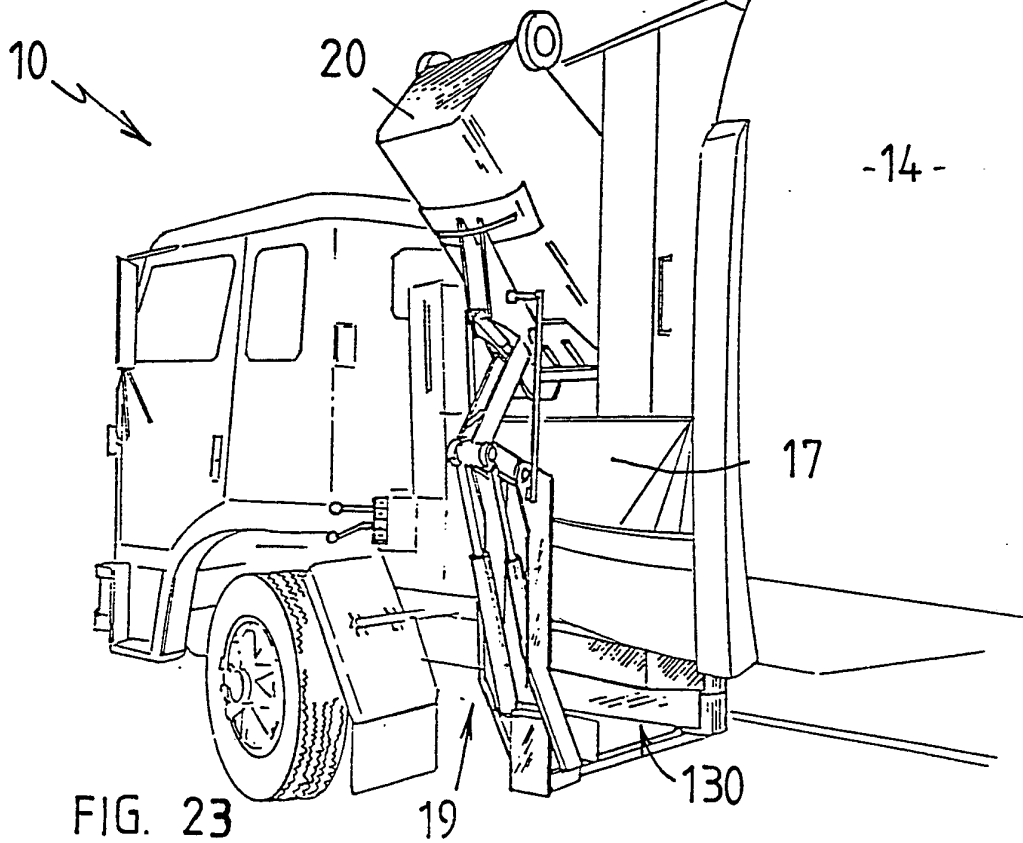



FIG. 23

-14-

INTERNATIONAL SEARCH REPORT

International application No.
PCT/AU93/00052

A. CLASSIFICATION OF SUBJECT MATTER Int. Cl. ⁵ B65F 3/20, 3/12 According to International Patent Classification (IPC) or to both national classification and IPC		
B. FIELDS SEARCHED Minimum documentation searched (classification system followed by classification symbols) IPC B65F 3/20, 3/12 Documentation searched other than minimum documentation to the extent that such documents are included in the fields searched AU : IPC as above Electronic data base consulted during the international search (name of data base, and where practicable, search terms used)		
C. DOCUMENTS CONSIDERED TO BE RELEVANT		
Category *	Citation of document, with indication, where appropriate, of the relevant passages	Relevant to Claim No.
A A A A A	EP,A,117939 (GOVERNMENT INNOVATORS INC.) 12 September 1984 (12.09.84). US,A,3687313 (SMITH) 29 August 1972 (29.08.72) GB,A,2138386 (COFFEY et al.) 24 October 1984 (24.10.84) WO,90/11952 (NORBA AB) 18 October 1990 (18.10.90) DE,A,471774 (AUTOMOBILEWERKE H. BUSSING AG)	
<input checked="" type="checkbox"/> Further documents are listed in the continuation of Box C. <input checked="" type="checkbox"/> See patent family annex.		
* Special categories of cited documents :		
"A" document defining the general state of the art which is not considered to be of particular relevance "E" earlier document but published on or after the international filing date "L" document which may throw doubts on priority claim(s) or which is cited to establish the publication date of another citation or other special reason (as specified) "O" document referring to an oral disclosure, use, exhibition or other means "P" document published prior to the international filing date but later than the priority date claimed	"T" later document published after the international filing date or priority date and not in conflict with the application but cited to understand the principle or theory underlying the invention "X" document of particular relevance; the claimed invention cannot be considered novel or cannot be considered to involve an inventive step when the document is taken alone "Y" document of particular relevance; the claimed invention cannot be considered to involve an inventive step when the document is combined with one or more other such documents, such combination being obvious to a person skilled in the art "&" document member of the same patent family	
Date of the actual completion of the international search 16 March 1993 (16.03.93)	Date of mailing of the international search report 1 APR 1993 (1.4.93)	
Name and mailing address of the ISA/AU AUSTRALIAN PATENT OFFICE PO BOX 200 WODEN ACT 2606 AUSTRALIA Facsimile No. 06 2853929	Authorized officer  M.G. Raymond Telephone No. (06) 2832114	

INTERNATIONAL SEARCH REPORT

International application No.
PCT/AU93/00052

C(Continuation). DOCUMENTS CONSIDERED TO BE RELEVANT		
Category*	Citation of document, with indication, where appropriate of the relevant passages	Relevant to Claim No.
A	EP,A,51243 (GEBRUDER OTTO KG)	
A	US,A,3709388 (NEUFELDT) 9 January 1973 (09.01.73)	

