



US00D926820S

(12) **United States Design Patent**  
**Gasman et al.**

(10) **Patent No.:** **US D926,820 S**  
(45) **Date of Patent:** **\*\* Aug. 3, 2021**

- (54) **PORTION OF VOLUTE CASING FOR A PUMP**
- (71) Applicant: **Sulzer Management AG**, Winterthur (CH)
- (72) Inventors: **Teemu Gasman**, Kotka (FI); **Matti Koivikko**, Kotka (FI); **Sami Virtanen**, Kotka (FI)
- (73) Assignee: **SULZER MANAGEMENT AG**, Winterthur (CH)
- (\*\*) Term: **15 Years**
- (21) Appl. No.: **29/551,965**
- (22) Filed: **Jan. 19, 2016**
- (30) **Foreign Application Priority Data**  
 Aug. 20, 2015 (EM) ..... 002757914
- (51) **LOC (13) Cl.** ..... **15-02**
- (52) **U.S. Cl.**  
 USPC ..... **D15/7**
- (58) **Field of Classification Search**  
 USPC ..... D25/125; 415/200, 182.1; 156/153, 160; 427/299; D15/7-9; D23/231, 232, 225  
 CPC ..... B29C 64/20; B29C 70/48; B29C 70/865; Y10T 156/1064; F21S 88/088; F21V 21/116; G09F 2013/0431  
 See application file for complete search history.

4,900,222 A	2/1990	Meng et al.	
4,974,998 A *	12/1990	Heineman	F04D 29/4286 406/193
5,485,909 A *	1/1996	Hay	F04D 5/001 198/642
D375,148 S *	10/1996	Keller	D23/249
5,599,600 A *	2/1997	Rau	B29C 73/04 285/917
D381,339 S *	7/1997	Wightley	D15/7
5,711,581 A *	1/1998	Plumer	B60B 3/145 301/35.632
5,885,065 A *	3/1999	Long	F01C 21/0872 418/1
D413,377 S *	8/1999	Pauly	D23/261
6,065,929 A *	5/2000	Morel	F04D 29/669 415/173.1
D437,034 S *	1/2001	Stout, Jr.	D23/269
6,196,257 B1 *	3/2001	Adler	E03F 5/041 137/362
6,290,279 B1 *	9/2001	Haight	B60R 13/07 220/235
6,687,925 B2 *	2/2004	Minnick	E03F 5/0407 4/286
6,694,566 B1 *	2/2004	Mockett	A47B 21/06 108/50.02
D539,117 S *	3/2007	Sealey	D8/349
D545,326 S *	6/2007	Zellers	D15/7
D553,238 S *	10/2007	Haggkvist	D23/386
D563,206 S *	3/2008	Bakker	D8/356
D576,480 S *	9/2008	Vakiener	D8/397
D609,248 S *	2/2010	Foreman	D15/7
D609,250 S *	2/2010	Liu	D15/7
D610,165 S *	2/2010	Glaves	D15/7
D616,902 S *	6/2010	Foreman	D15/7
D616,966 S *	6/2010	Angell	D23/262
7,735,512 B1 *	6/2010	Ismert	E03F 5/0407 137/362
D626,208 S *	10/2010	Clements	D23/386
D627,490 S *	11/2010	Janish	D25/199
D631,142 S *	1/2011	Angell	D23/262
D658,478 S *	5/2012	Wall	D8/349
D659,718 S *	5/2012	Seidel	D15/9
D660,691 S *	5/2012	Yamazaki	D8/399
D698,017 S *	1/2014	Modesto	D23/365
8,747,062 B2 *	6/2014	Burgess	F04D 29/428 415/197
8,790,077 B2 *	7/2014	Burgess	F04D 29/4286 415/127
D712,156 S *	9/2014	Arvinte	D4/122
D729,924 S *	5/2015	Hsiao	D23/366
9,022,723 B2 *	5/2015	Leininger	G01F 13/001 415/62

(56) **References Cited**  
U.S. PATENT DOCUMENTS

3,016,562 A *	1/1962	Reid	H02G 3/083 16/2.1
4,455,842 A *	6/1984	Granlund	A01N 1/02 62/64
4,562,602 A *	1/1986	Cuschera	E03C 1/22 285/136.1
D285,044 S *	8/1986	Mockett	D8/349
4,883,590 A *	11/1989	Papp	E03F 5/0407 210/164

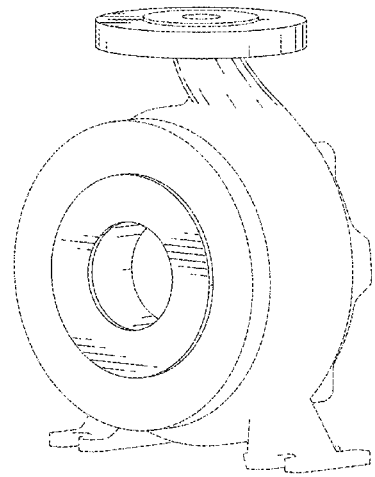

9,057,385	B2 *	6/2015	Burgess	.....	F04D 29/428
D740,327	S *	10/2015	Naruoka	.....	D15/5
D742,420	S *	11/2015	Sullivan	.....	D15/7
9,175,464	B2 *	11/2015	Meyers	.....	E03F 5/0408
D749,707	S *	2/2016	Kuang	.....	D23/263
D761,398	S *	7/2016	Murphy	.....	D23/269
D767,637	S *	9/2016	Pappathopoulos	.....	D15/7
D771,480	S *	11/2016	Lowitz	.....	D8/382
D780,226	S *	2/2017	Nelson	.....	D15/7
10,066,636	B2 *	9/2018	Welschinger	.....	F04D 29/083
D829,770	S *	10/2018	Gasman	.....	D15/7
D836,676	S *	12/2018	Geldenhuis	.....	D15/7
D842,904	S *	3/2019	Geldenhuis	.....	D15/7
2007/0014662	A1 *	1/2007	Burgess	.....	F04D 29/4286 415/197
2011/0101152	A1 *	5/2011	Molstad	.....	A47K 10/3836 242/606
2013/0154777	A1 *	6/2013	Virtanen	.....	G01R 33/3802 335/299
2014/0271162	A1	9/2014	Karl et al.		
2015/0040345	A1 *	2/2015	Loy	.....	B60R 16/0222 16/2.1
2015/0328874	A1 *	11/2015	Elliott	.....	B29C 70/48 156/153
2016/0004029	A1 *	1/2016	Tun	.....	G02B 7/02 359/819
2016/0247609	A1 *	8/2016	Wang	.....	H02G 3/22

FOREIGN PATENT DOCUMENTS

DE	2602624	A1	7/1976
DE	202009018129	U1	4/2011
DE	102009010927	A1	9/2019
EP	1855013	A2	4/2007
GB	2266750	A	11/1993
JP	57124098	A	8/1982
JP	05332300	A	12/1993

\* cited by examiner

Primary Examiner — Samantha Q Lawrence  
(74) Attorney, Agent, or Firm — Global IP Counselors, LLP

(57) CLAIM

The ornamental design for a portion of a pump having a volute casing, as shown and described.

DESCRIPTION

FIG. 1 is a perspective view of a portion of a volute casing for a pump in accordance with our new design;  
 FIG. 2 is a first side elevational view of the volute casing illustrated in FIG. 1;  
 FIG. 3 is a second side elevational view of the volute casing illustrated in FIG. 1;  
 FIG. 4 is a first end elevational view of the volute casing illustrated in FIG. 1;  
 FIG. 5 is a second end elevational view of the volute casing illustrated in FIG. 1;  
 FIG. 6 is a bottom plan view of the volute casing illustrated in FIG. 1;  
 FIG. 7 is a top plan view of the volute casing illustrated in FIG. 1;  
 FIG. 8 is a perspective view of a portion of a volute casing for a pump in accordance with our new design;  
 FIG. 9 is a first side elevational view of the volute casing illustrated in FIG. 8;  
 FIG. 10 is a second side elevational view of the volute casing illustrated in FIG. 8;

FIG. 11 is a first end elevational view of the volute casing illustrated in FIG. 8;  
 FIG. 12 is a second end elevational view of the volute casing illustrated in FIG. 8;  
 FIG. 13 is a bottom plan view of the volute casing illustrated in FIG. 8;  
 FIG. 14 is a top plan view of the volute casing illustrated in FIG. 8;  
 FIG. 15 is a perspective view of a portion of a volute casing for a pump in accordance with our new design;  
 FIG. 16 is a first side elevational view of the volute casing illustrated in FIG. 15;  
 FIG. 17 is a second side elevational view of the volute casing illustrated in FIG. 15;  
 FIG. 18 is a first end elevational view of the volute casing illustrated in FIG. 15;  
 FIG. 19 is a second end elevational view of the volute casing illustrated in FIG. 15;  
 FIG. 20 is a bottom plan view of the volute casing illustrated in FIG. 15;  
 FIG. 21 is a top plan view of the volute casing illustrated in FIG. 15;  
 FIG. 22 is a perspective view of a portion of a volute casing for a pump in accordance with our new design;  
 FIG. 23 is a first side elevational view of the volute casing illustrated in FIG. 22;  
 FIG. 24 is a second side elevational view of the volute casing illustrated in FIG. 22;  
 FIG. 25 is a first end elevational view of the volute casing illustrated in FIG. 22;  
 FIG. 26 is a second end elevational view of the volute casing illustrated in FIG. 22;  
 FIG. 27 is a bottom plan view of the volute casing illustrated in FIG. 22;  
 FIG. 28 is a top plan view of the volute casing illustrated in FIG. 22;  
 FIG. 29 is a perspective view of a portion of a volute casing for a pump in accordance with our new design;  
 FIG. 30 is a first side elevational view of the volute casing illustrated in FIG. 29;  
 FIG. 31 is a second side elevational view of the volute casing illustrated in FIG. 29;  
 FIG. 32 is a first end elevational view of the volute casing illustrated in FIG. 29;  
 FIG. 33 is a second end elevational view of the volute casing illustrated in FIG. 29;  
 FIG. 34 is a bottom plan view of the volute casing illustrated in FIG. 29;  
 FIG. 35 is a top plan view of the volute casing illustrated in FIG. 29;  
 FIG. 36 is a perspective view of a portion of a volute casing for a pump in accordance with our new design;  
 FIG. 37 is a first side elevational view of the volute casing illustrated in FIG. 36;  
 FIG. 38 is a second side elevational view of the volute casing illustrated in FIG. 36;  
 FIG. 39 is a first end elevational view of the volute casing illustrated in FIG. 36;  
 FIG. 40 is a second end elevational view of the volute casing illustrated in FIG. 36;  
 FIG. 41 is a bottom plan view of the volute casing illustrated in FIG. 36;  
 FIG. 42 is a top plan view of the volute casing illustrated in FIG. 36;



FIG. 93 is a first side elevational view of the volute casing illustrated in FIG. 92;

FIG. 94 is a second side elevational view of the volute casing illustrated in FIG. 92;

FIG. 95 is a first end elevational view of the volute casing illustrated in FIG. 92;

FIG. 96 is a second end elevational view of the volute casing illustrated in FIG. 92;

FIG. 97 is a bottom plan view of the volute casing illustrated in FIG. 92;

FIG. 98 is a top plan view of the volute casing illustrated in FIG. 92;

FIG. 99 is a perspective view of a portion of a volute casing for a pump in accordance with our new design;

FIG. 100 is a first side elevational view of the volute casing illustrated in FIG. 99;

FIG. 101 is a second side elevational view of the volute casing illustrated in FIG. 99;

FIG. 102 is a first end elevational view of the volute casing illustrated in FIG. 99;

FIG. 103 is a second end elevational view of the volute casing illustrated in FIG. 99;

FIG. 104 is a bottom plan view of the volute casing illustrated in FIG. 99; and,

FIG. 105 is a top plan view of the volute casing illustrated in FIG. 99.

The broken lines shown in the Figures illustrate portions of the portion of volute casing for a pump and form no part of the claimed design.

**1 Claim, 105 Drawing Sheets**

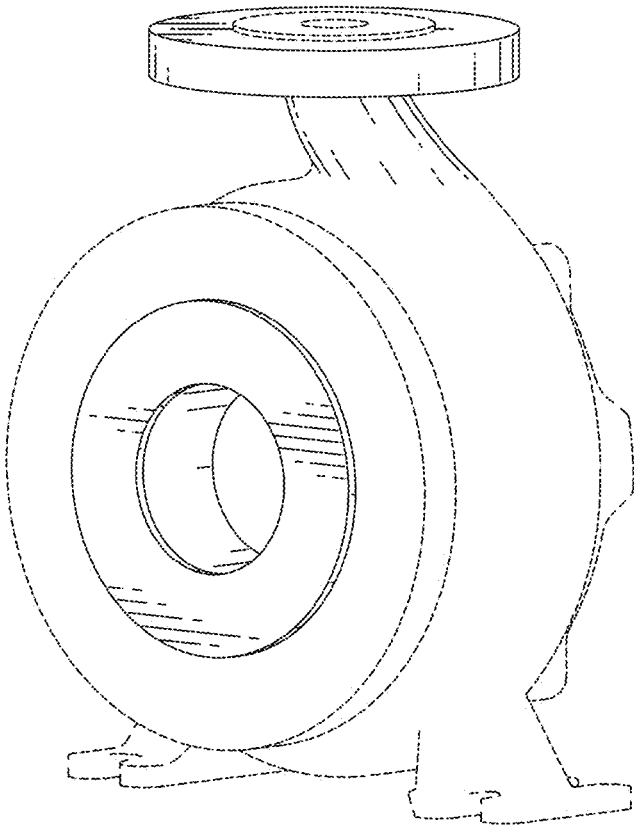

FIG. 1

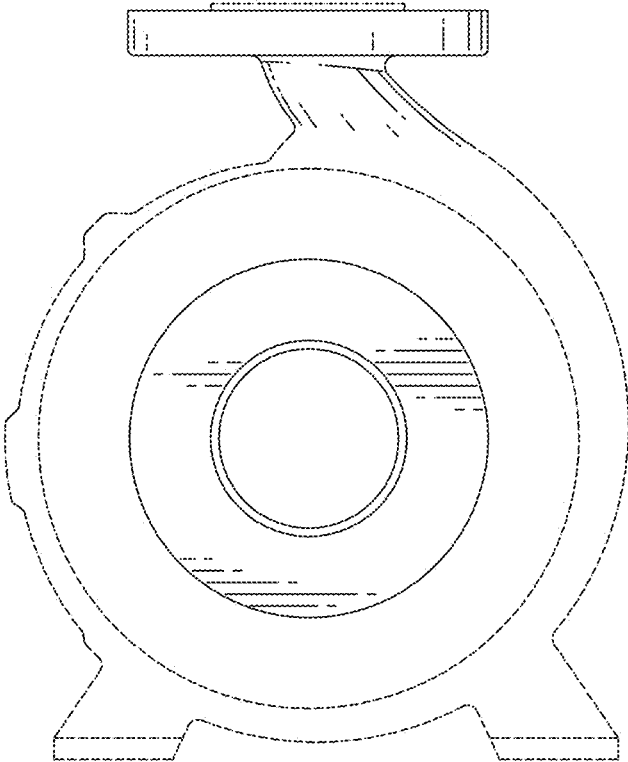

FIG. 2

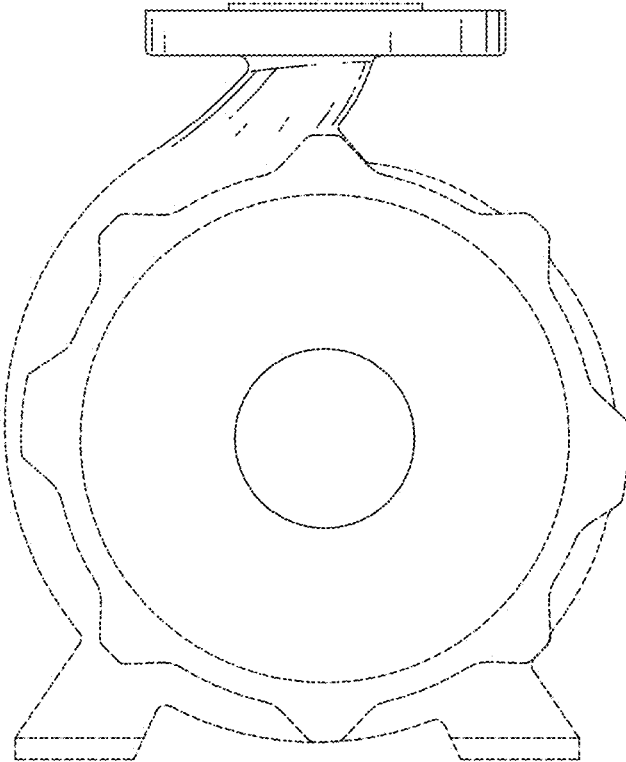

FIG. 3

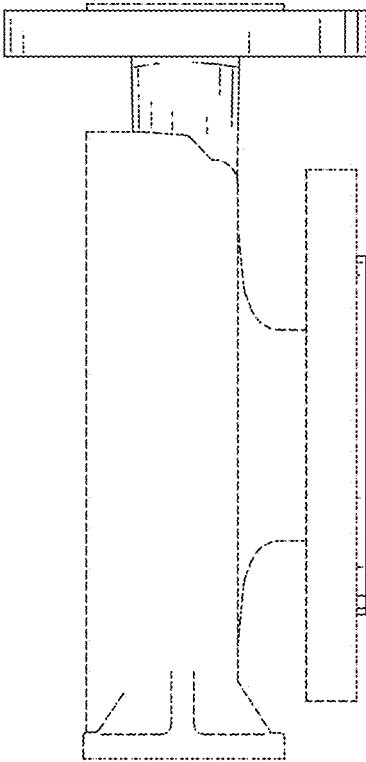

FIG. 4

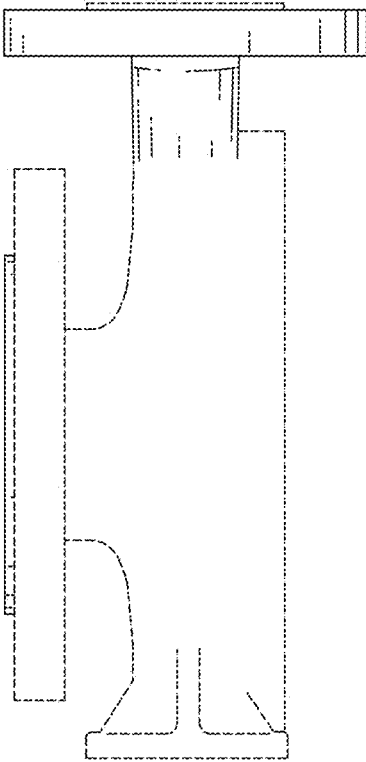

FIG. 5

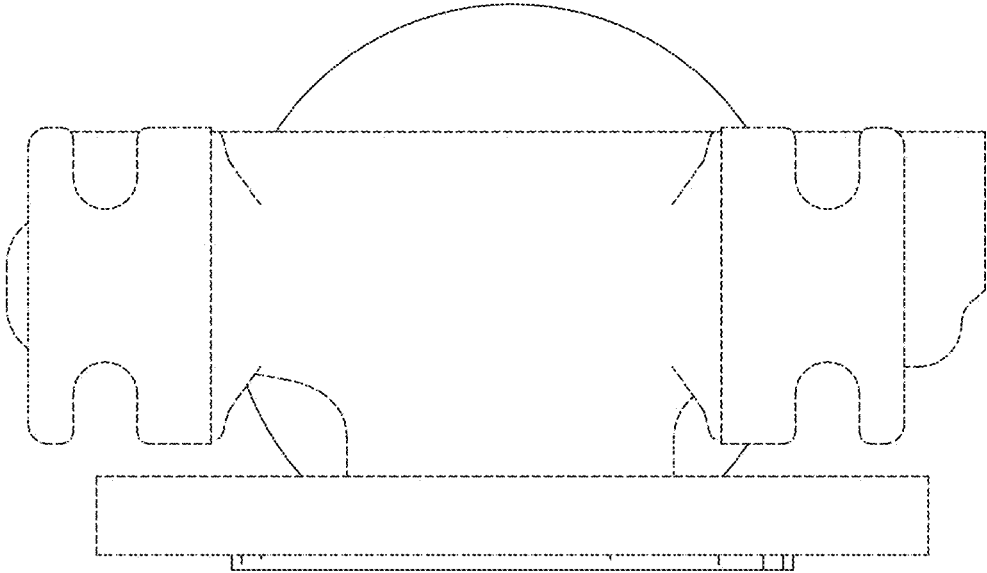

FIG. 6

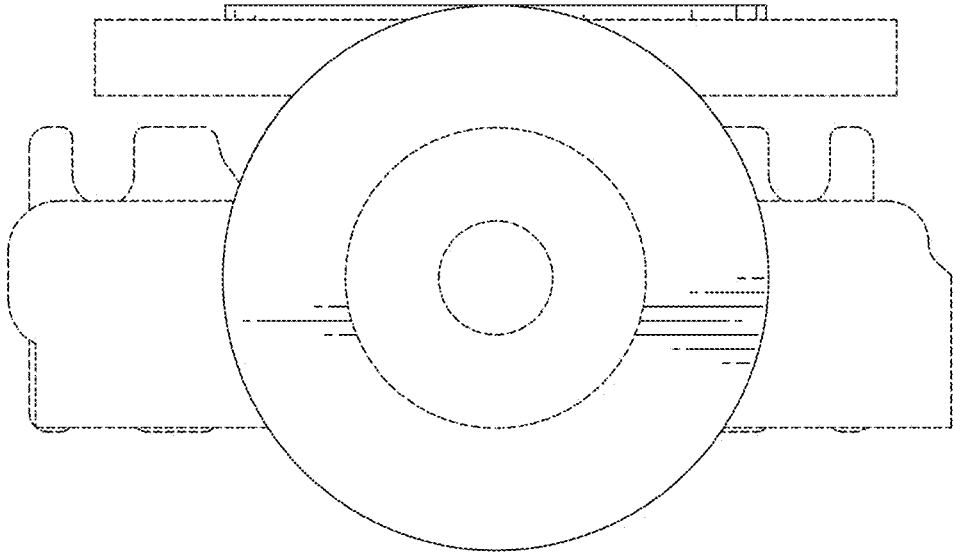

FIG. 7

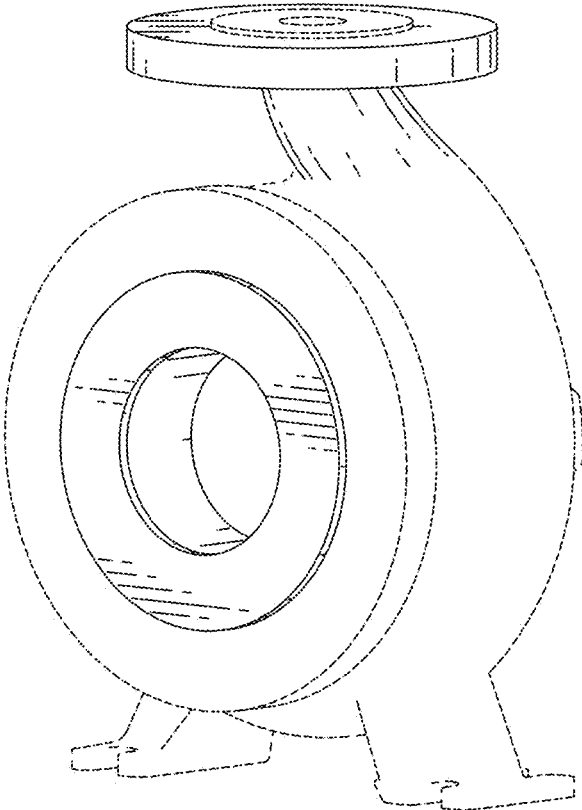

FIG. 8

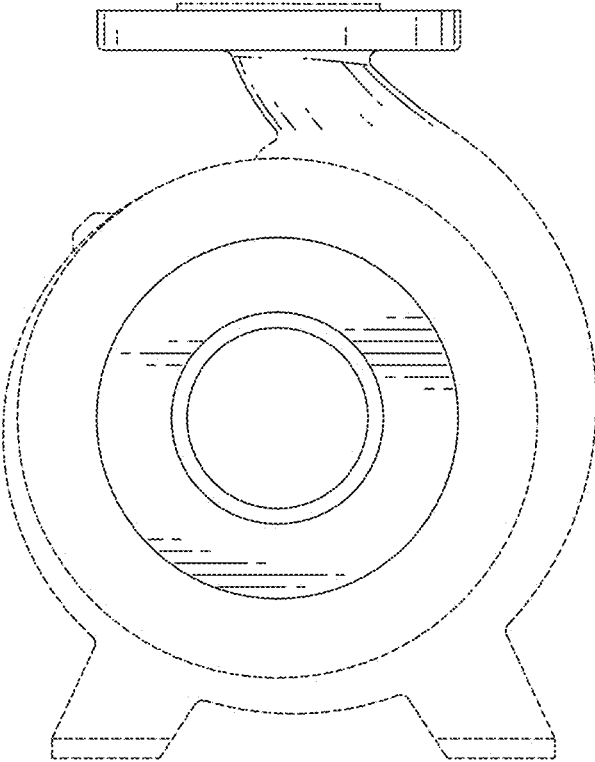

FIG. 9

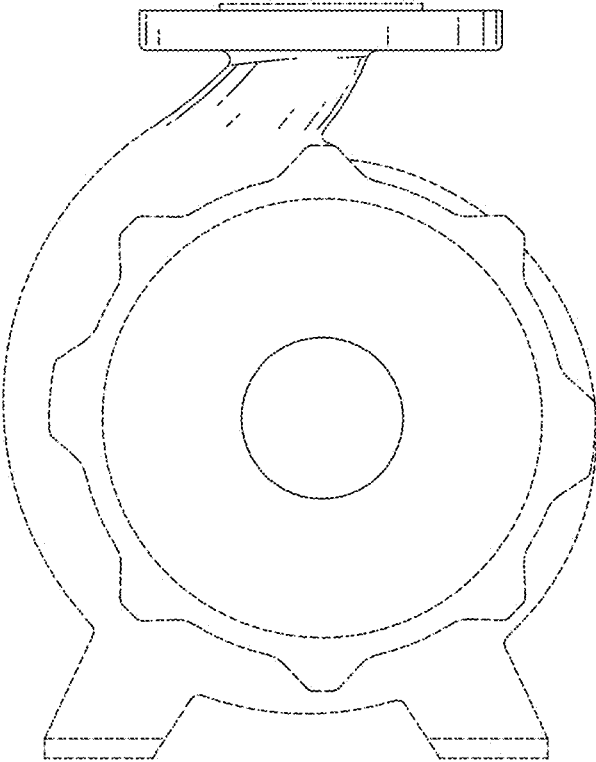

FIG. 10

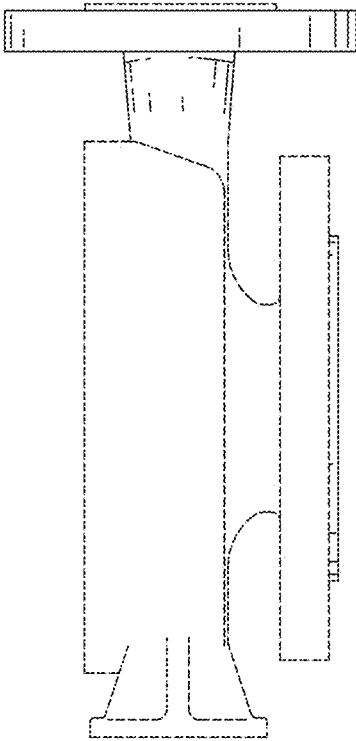

FIG. 11

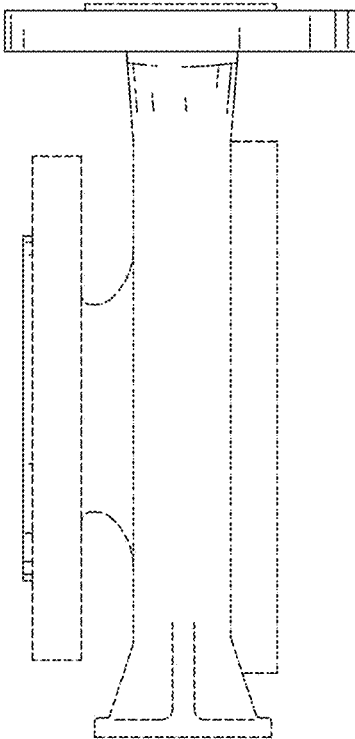

FIG. 12

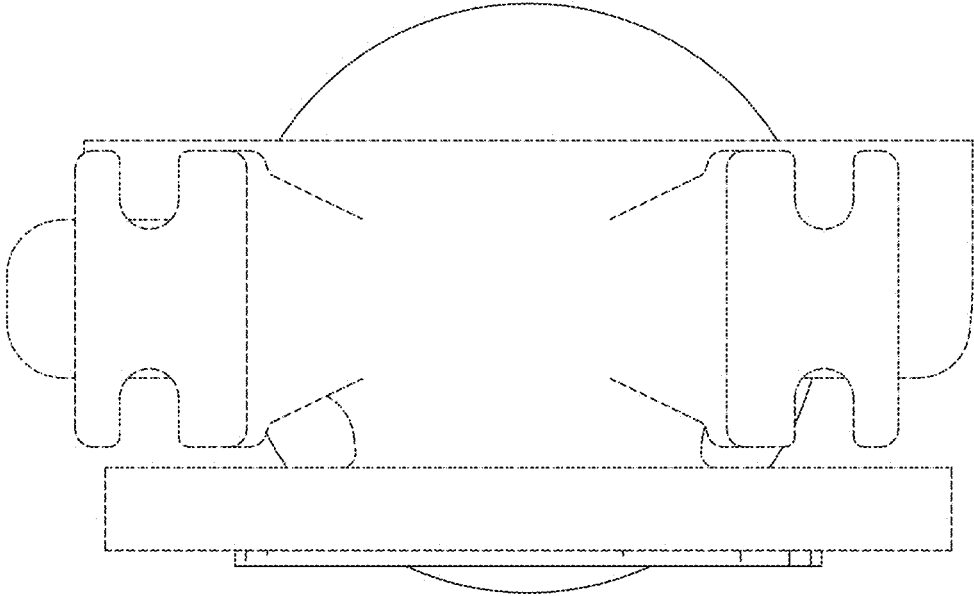

FIG. 13

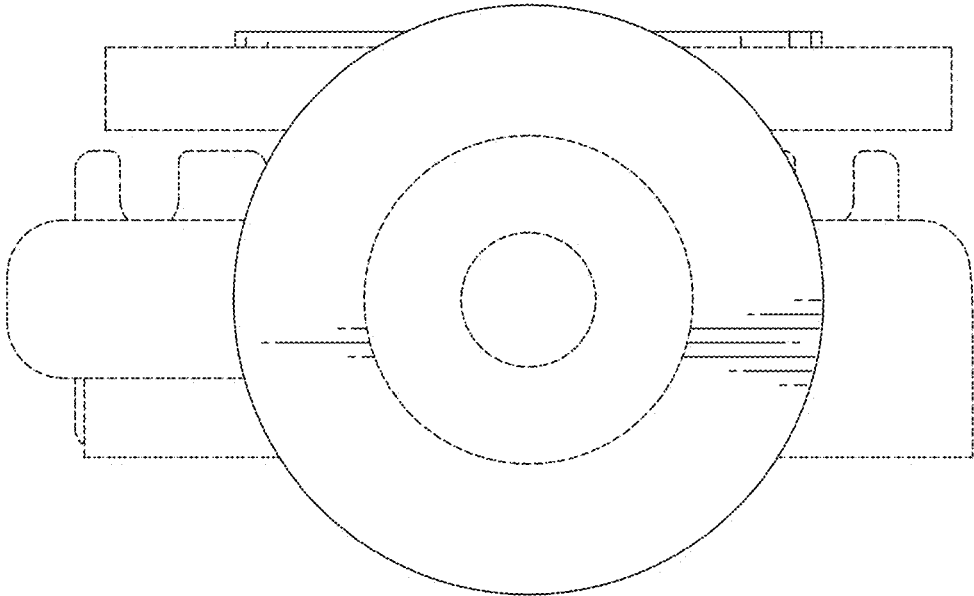

FIG. 14

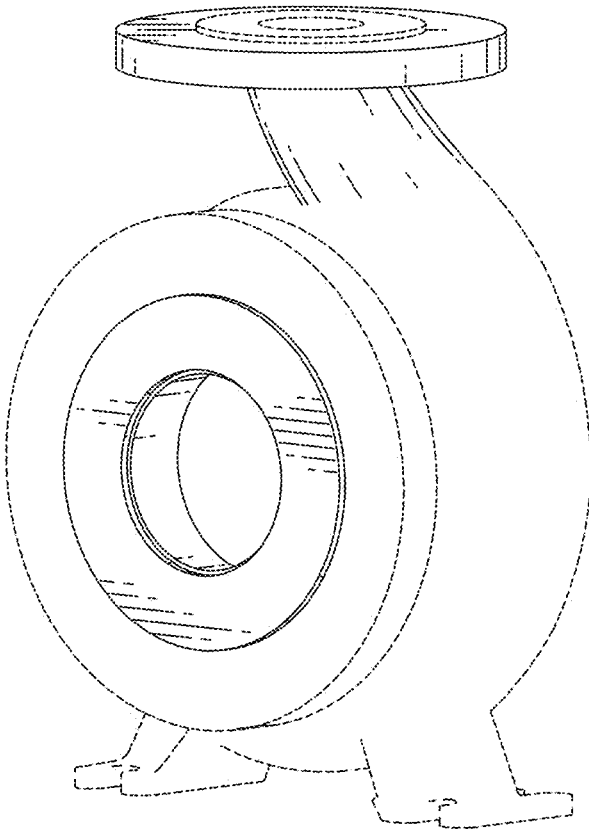

FIG. 15

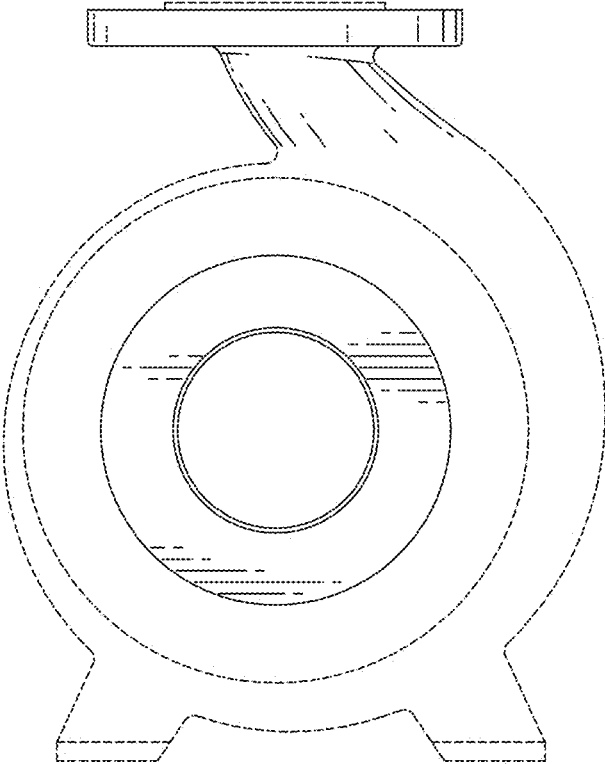

FIG. 16

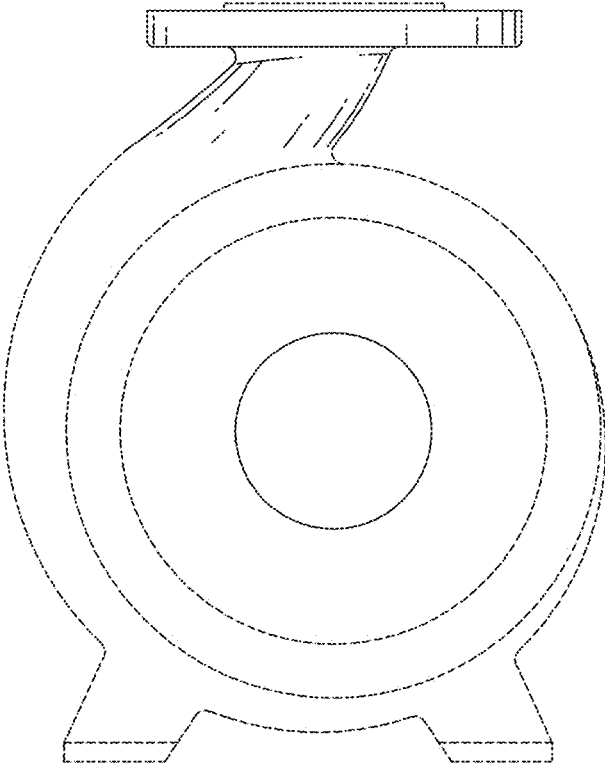

FIG. 17

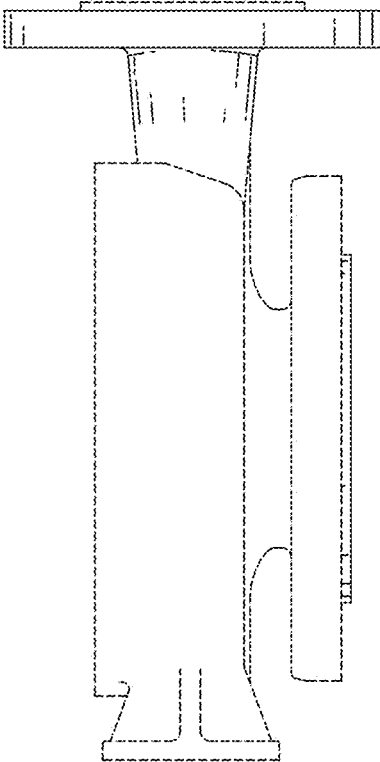

FIG. 18

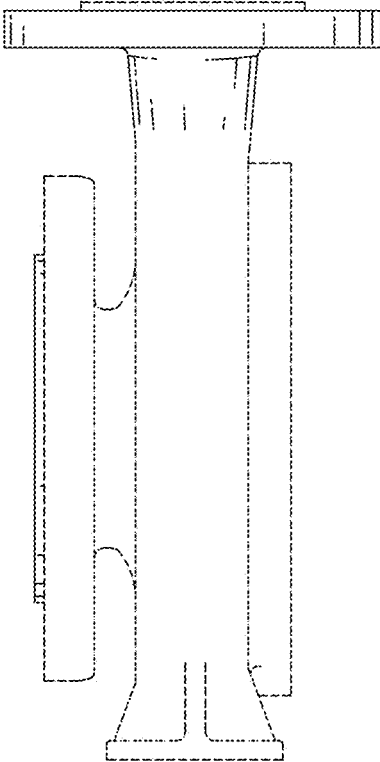

FIG. 19

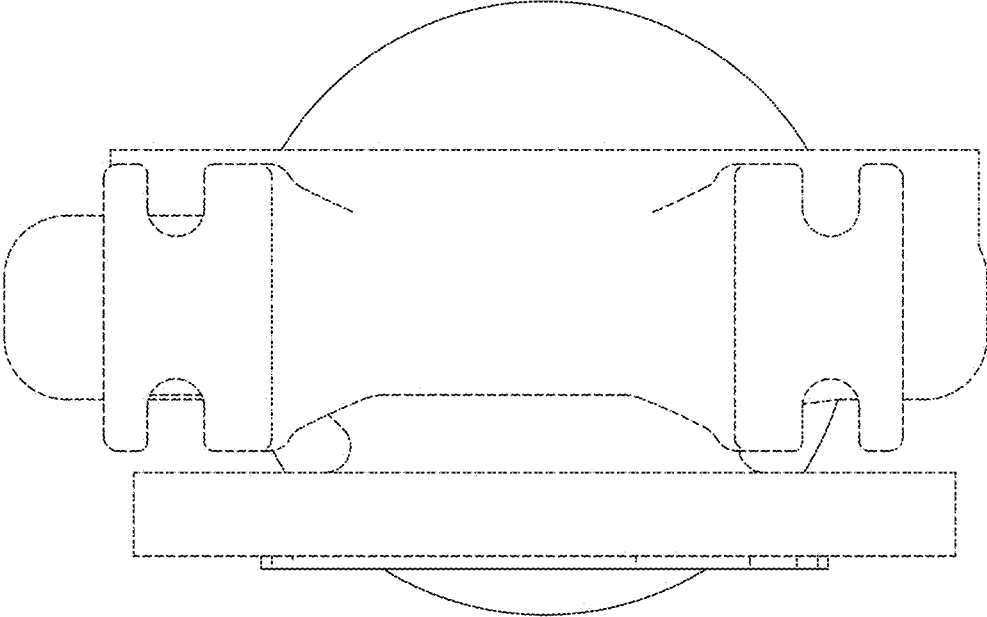

FIG. 20

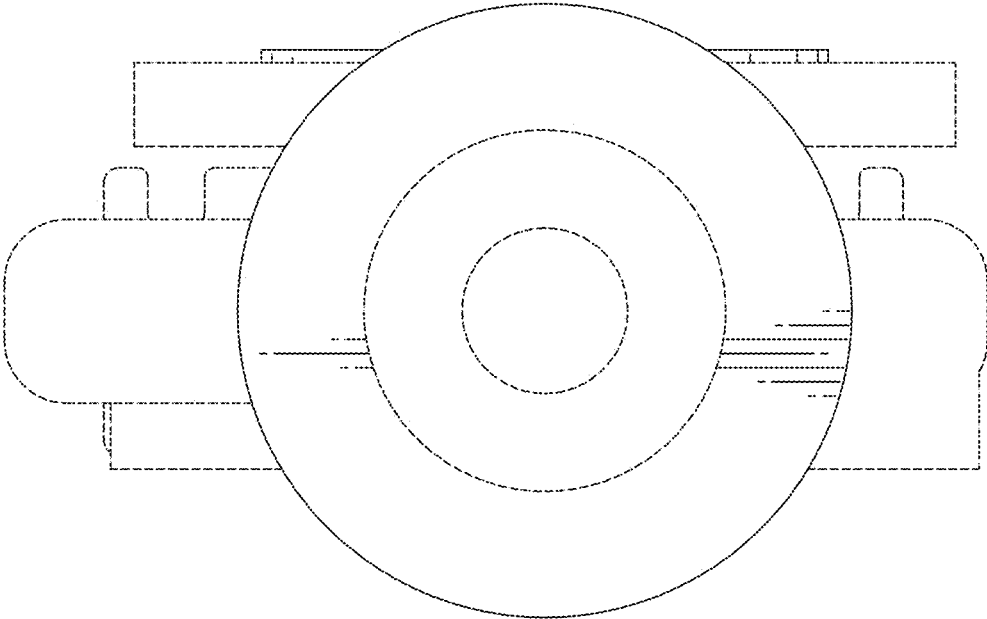

FIG. 21

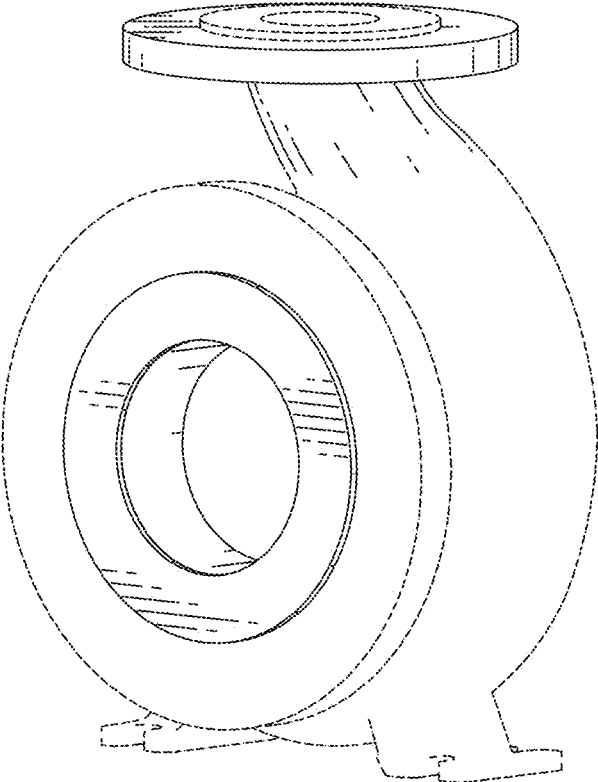

FIG. 22

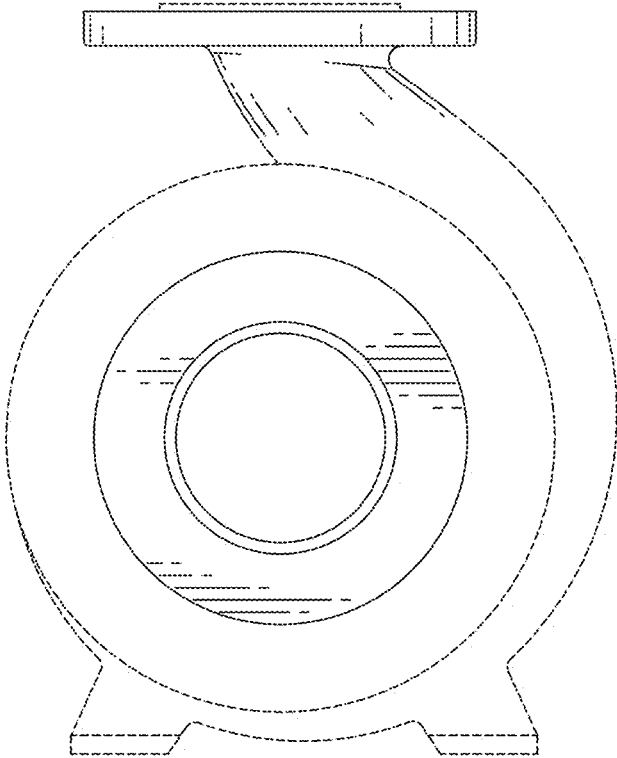

FIG. 23

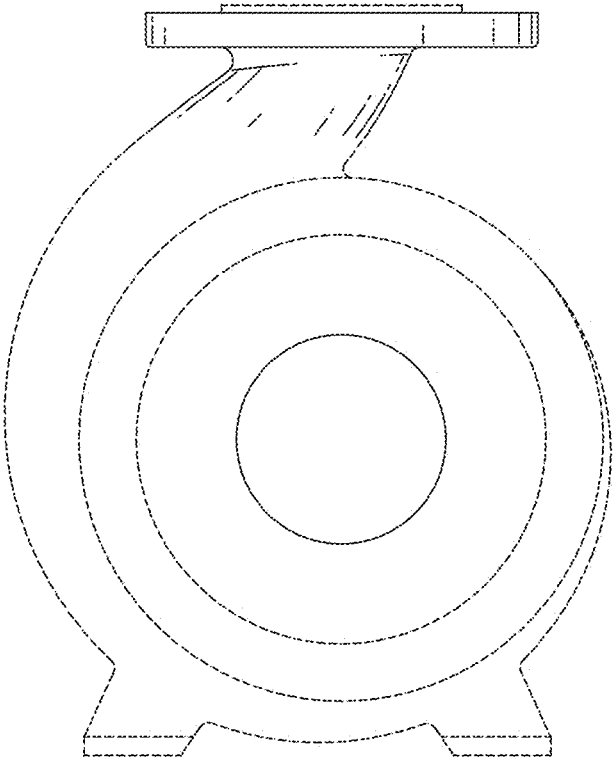

FIG. 24

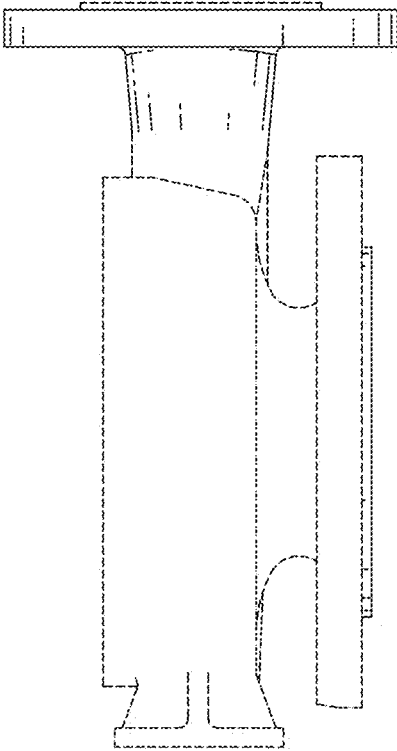

FIG. 25

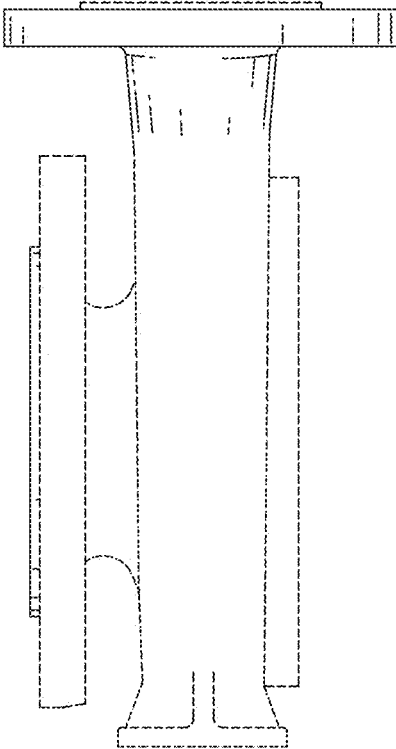

FIG. 26

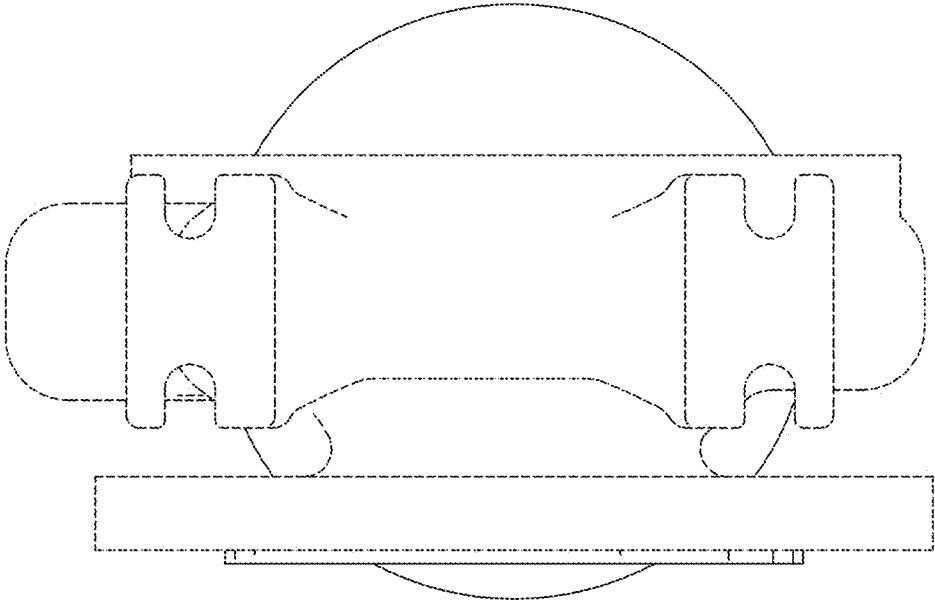

FIG. 27

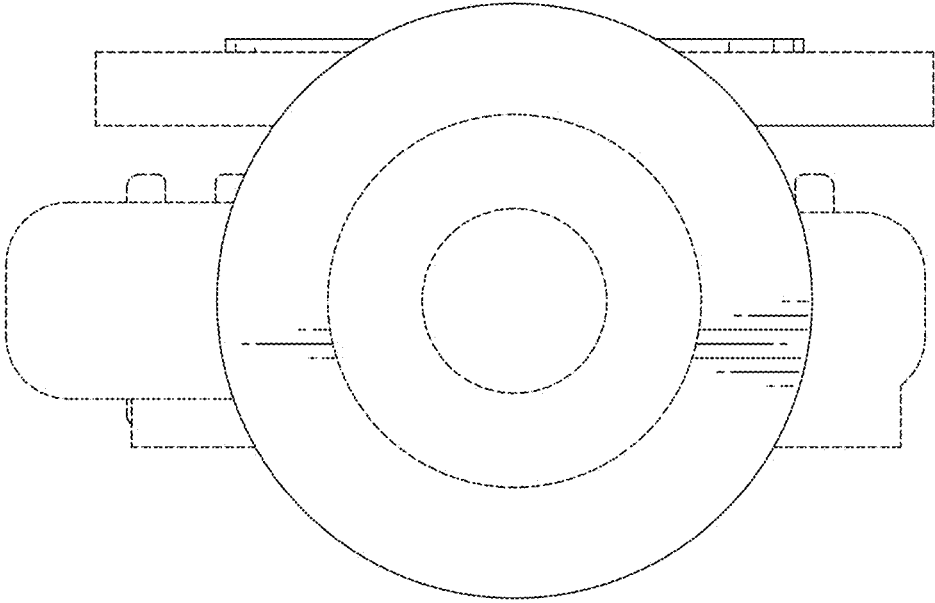

FIG. 28

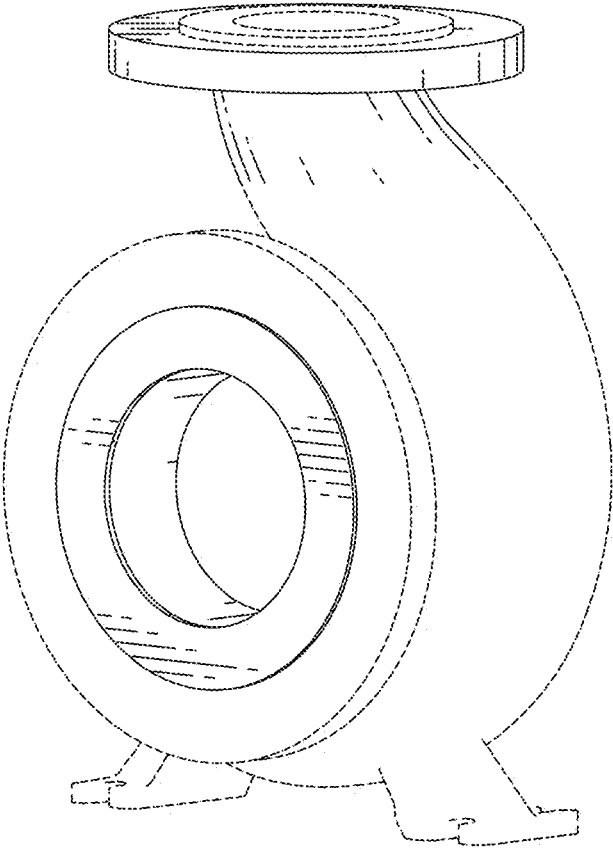

FIG. 29

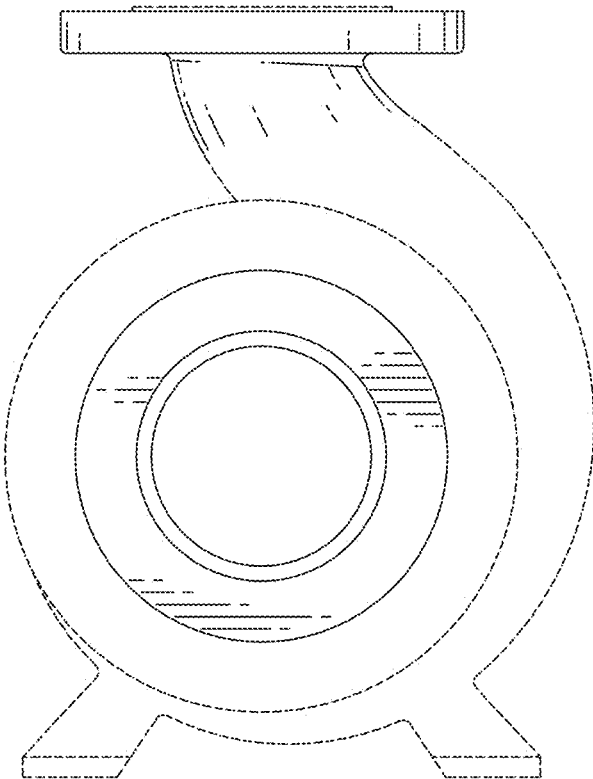

FIG. 30

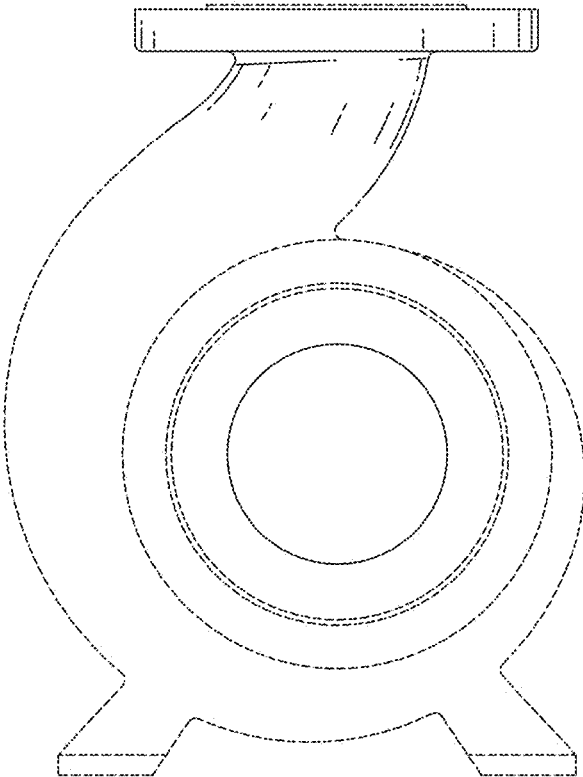

FIG. 31

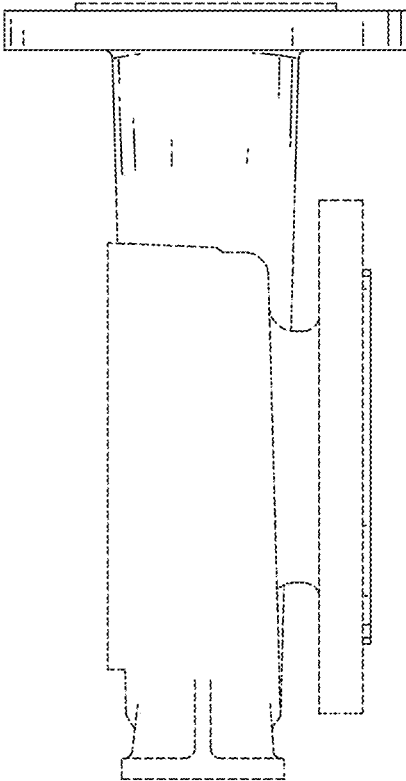

FIG. 32

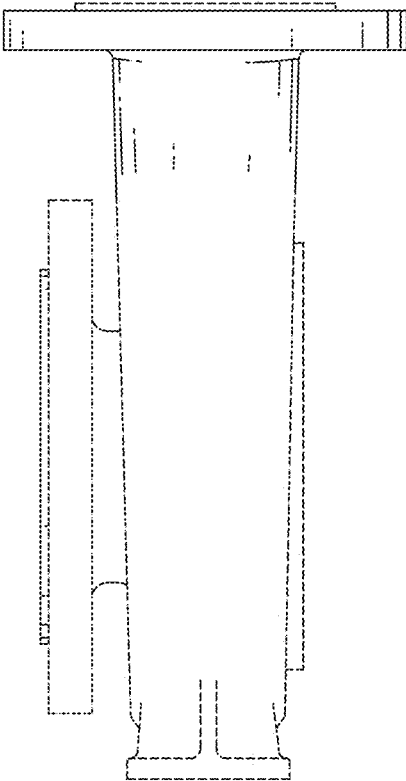

FIG. 33

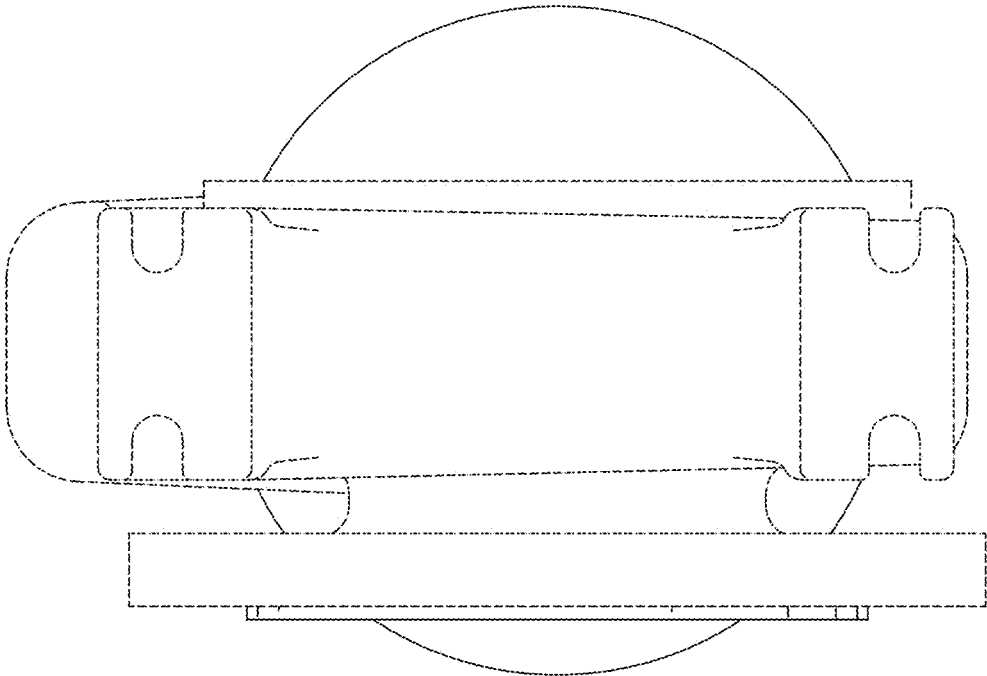

FIG. 34

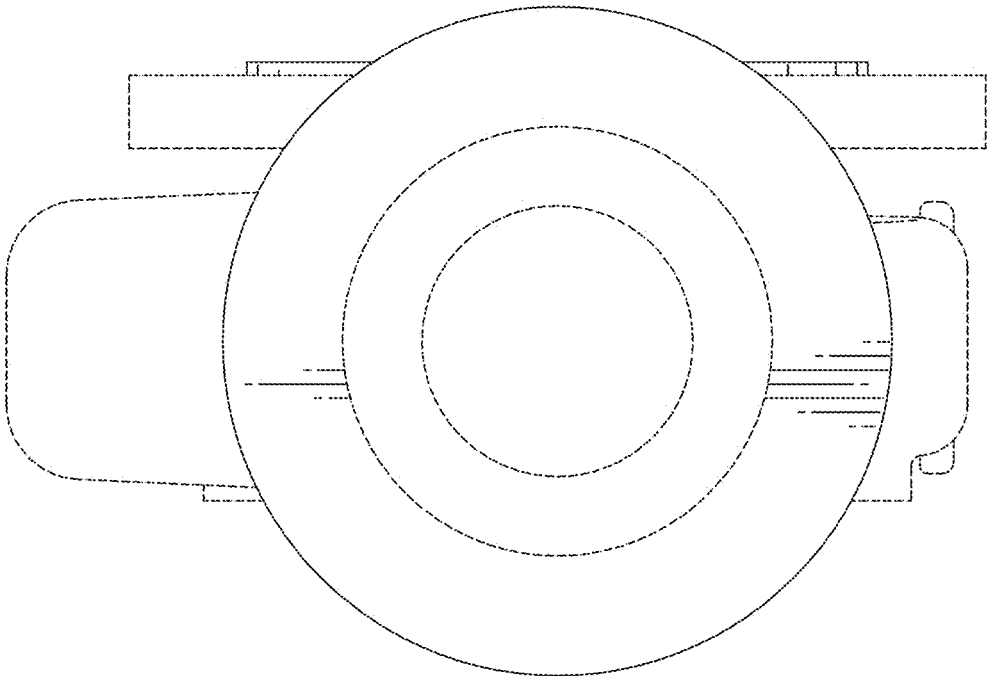

FIG. 35

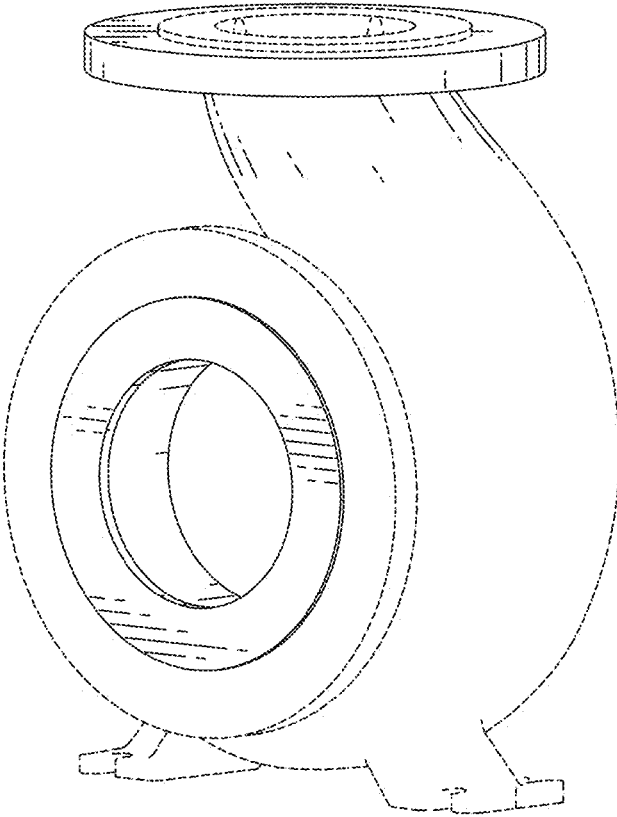

FIG. 36

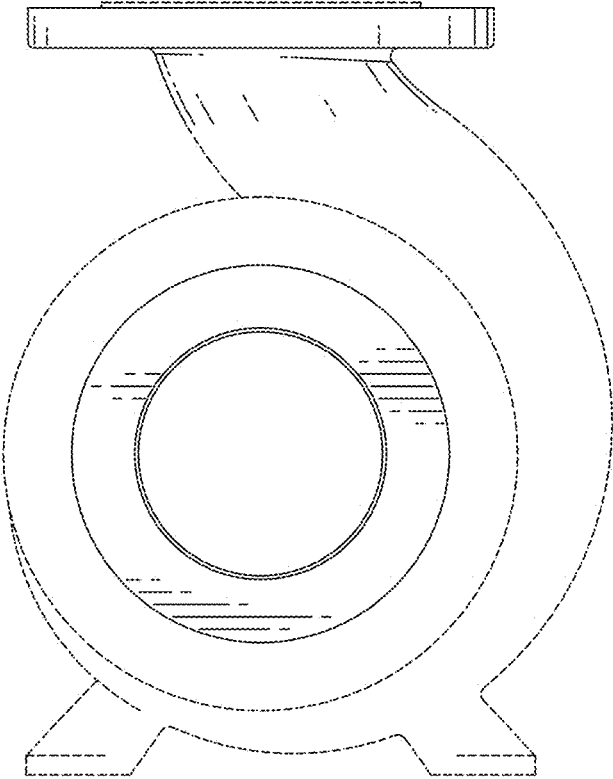

FIG. 37

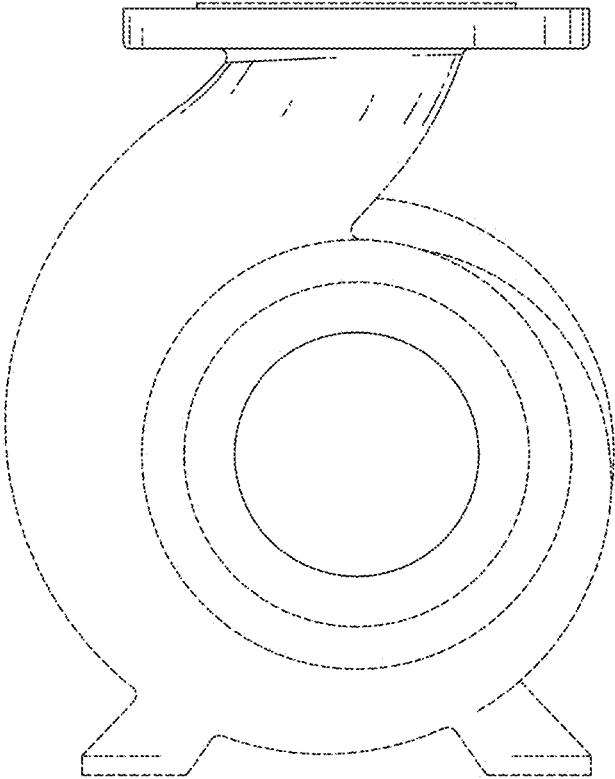

FIG. 38

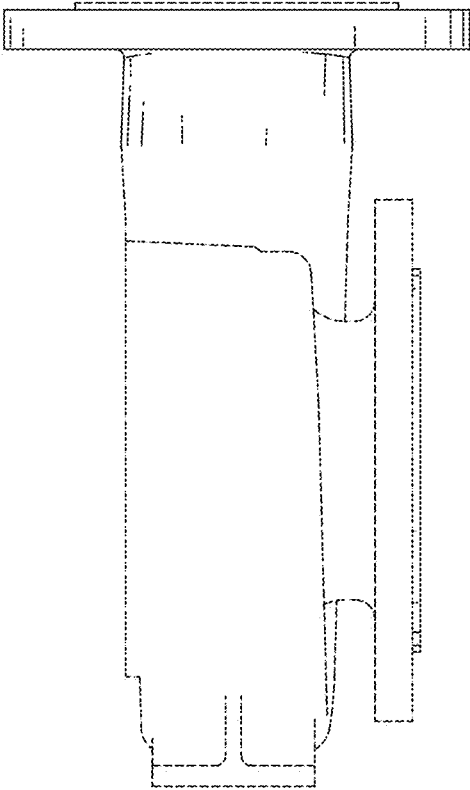

FIG. 39

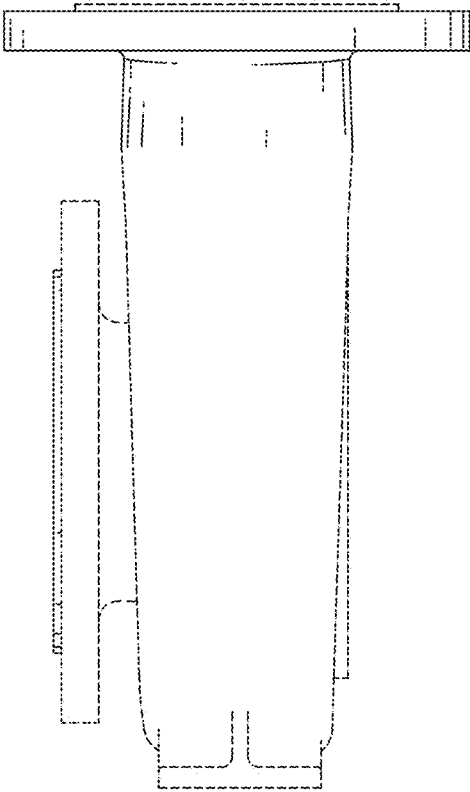

FIG. 40

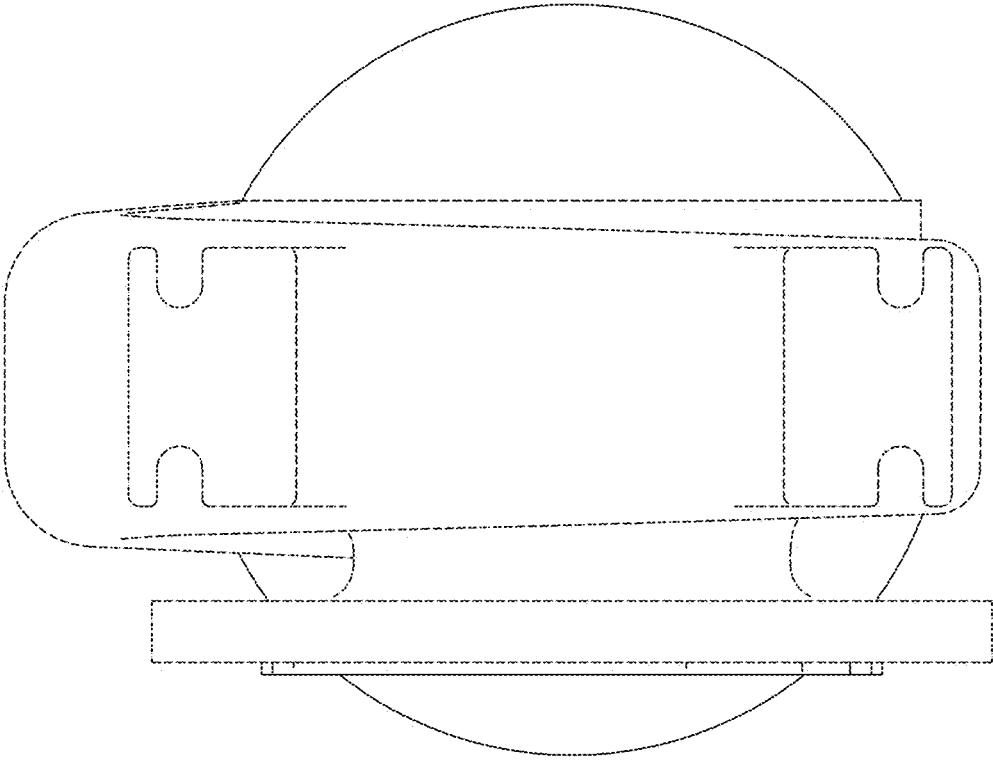

FIG. 41

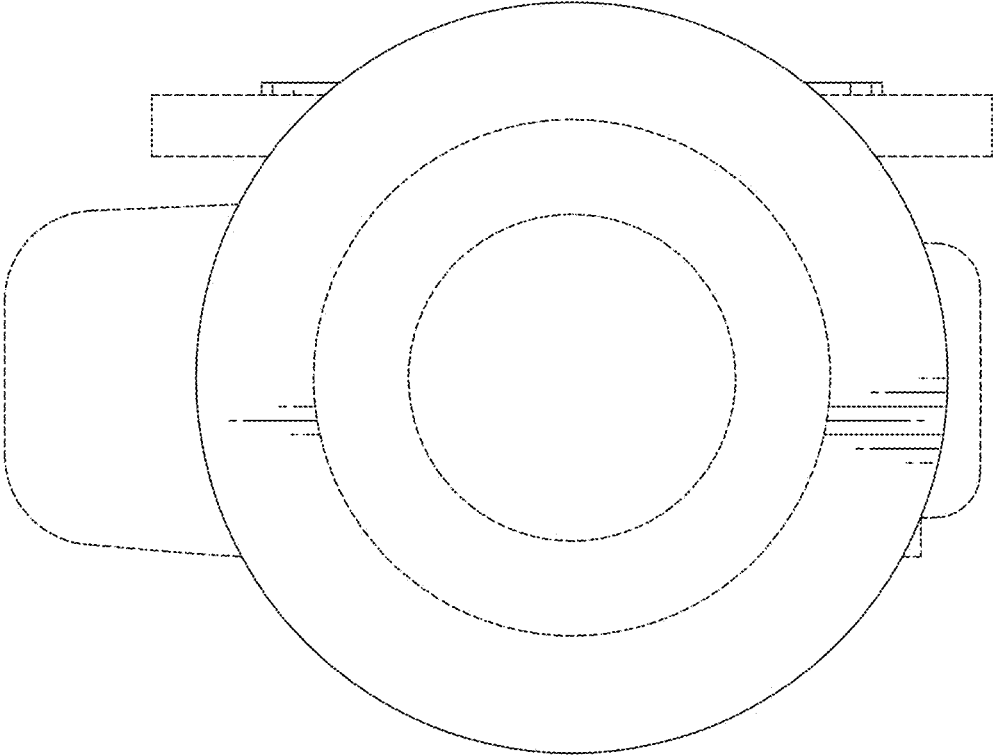

FIG. 42

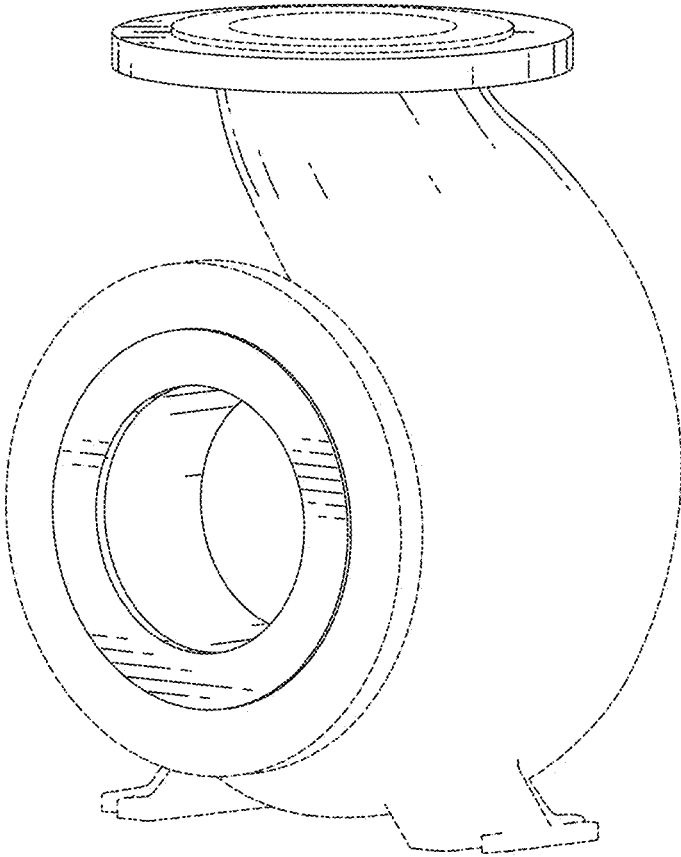

FIG. 43

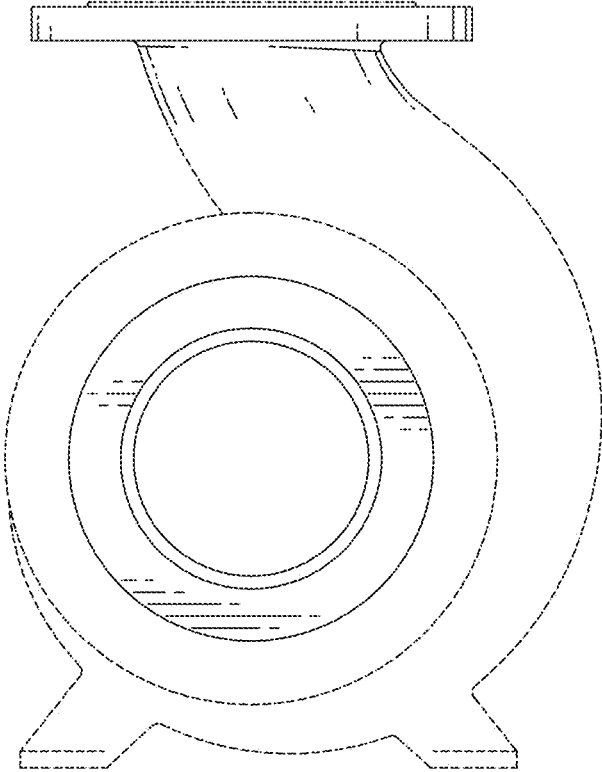

FIG. 44

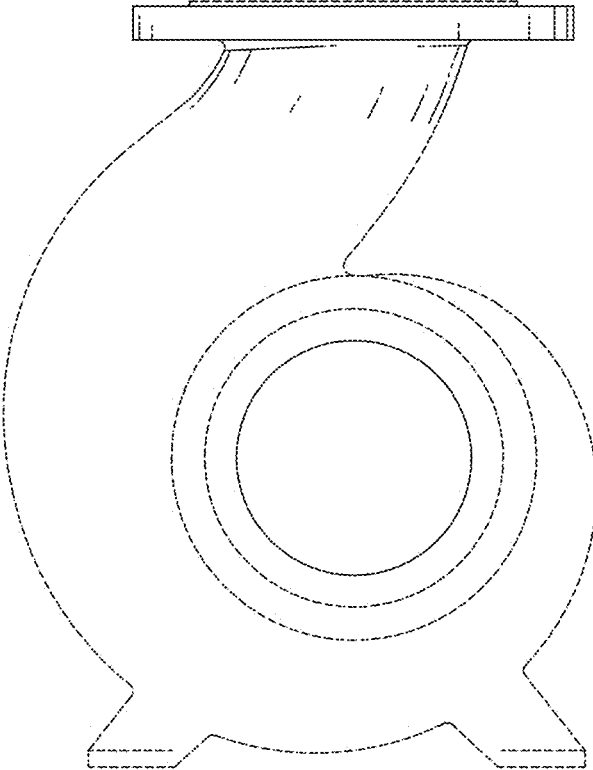

FIG. 45

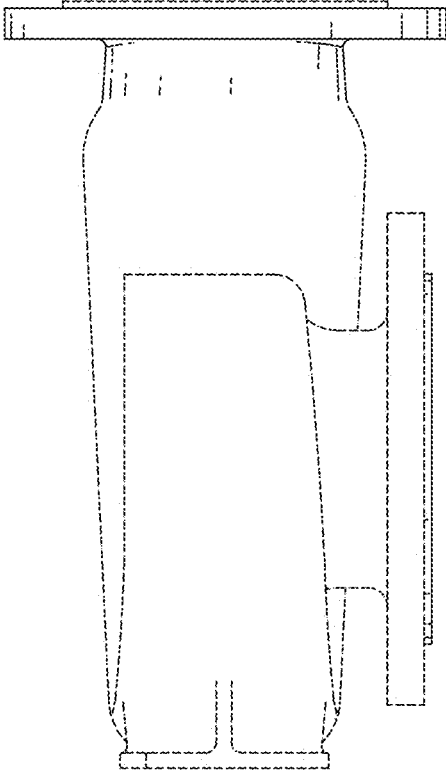

FIG. 46

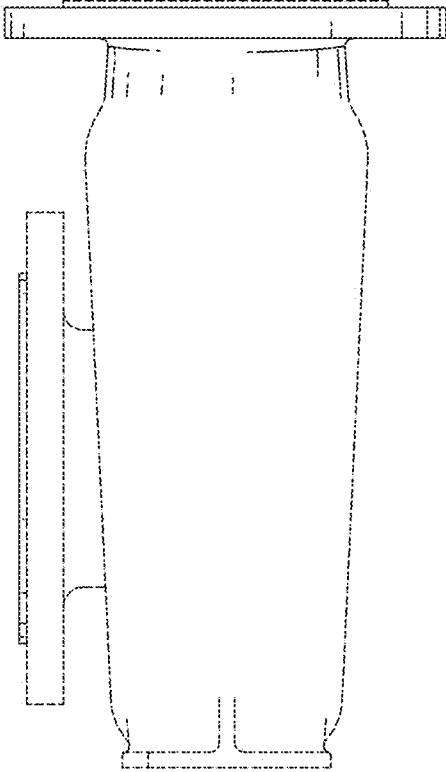

FIG. 47

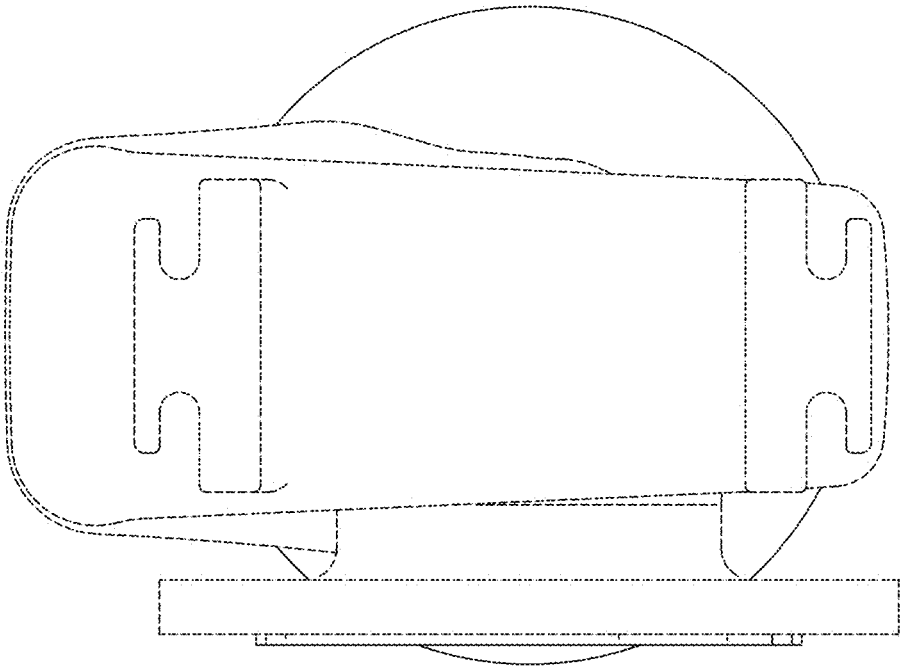

FIG. 48

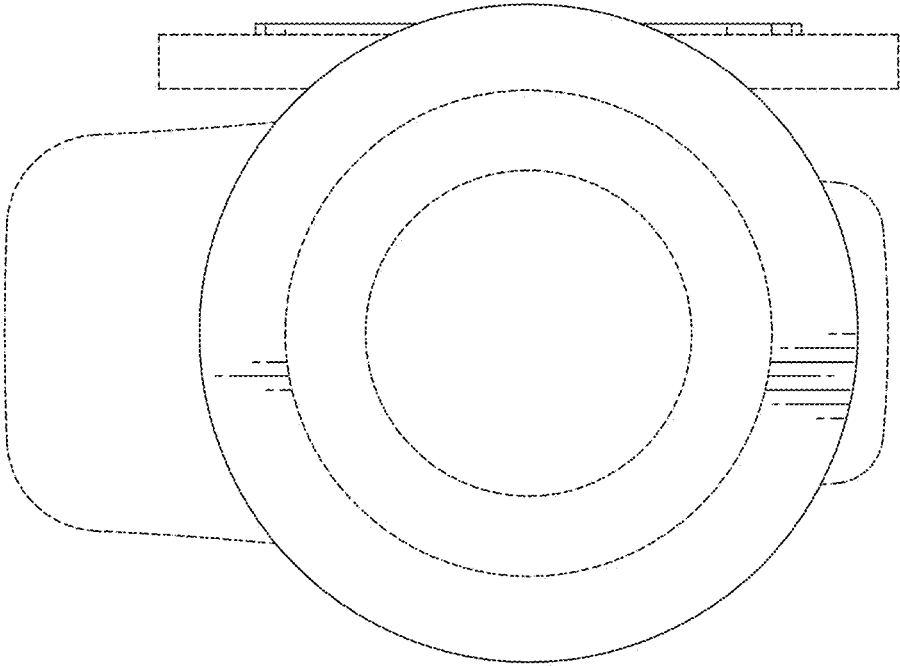

FIG. 49

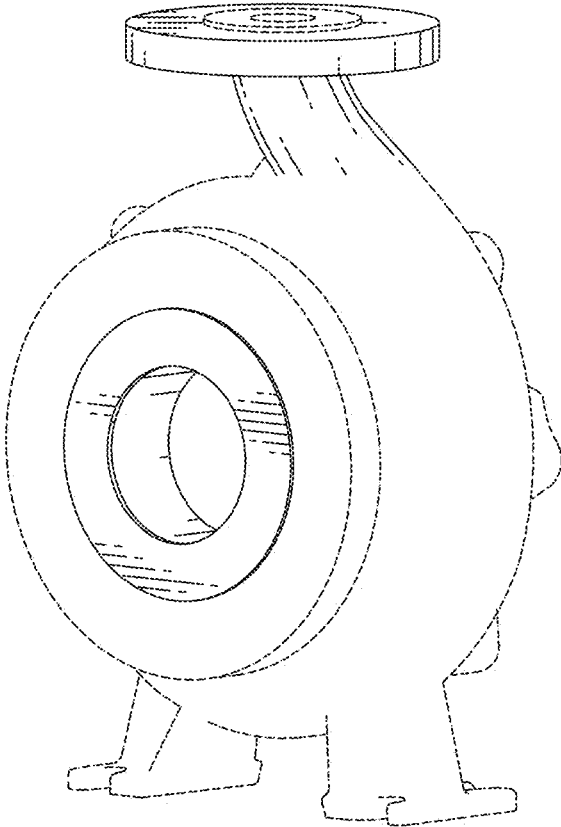

FIG. 50

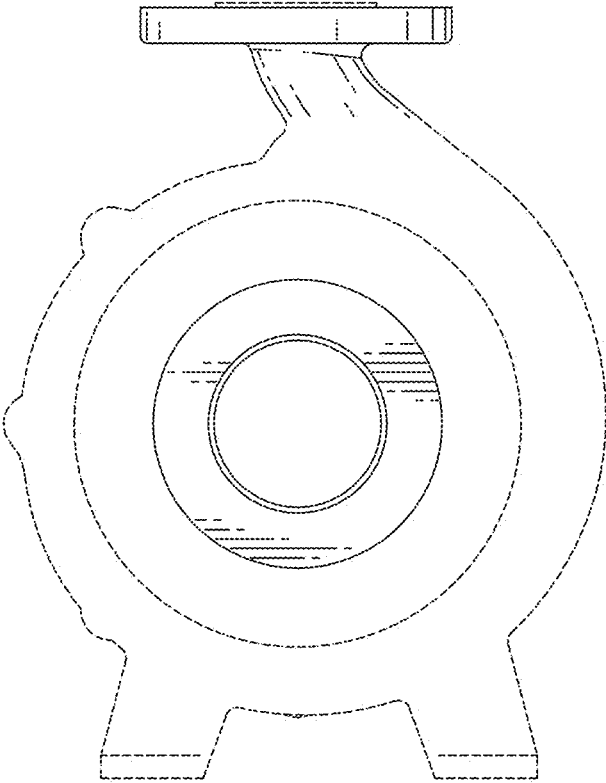

FIG. 51

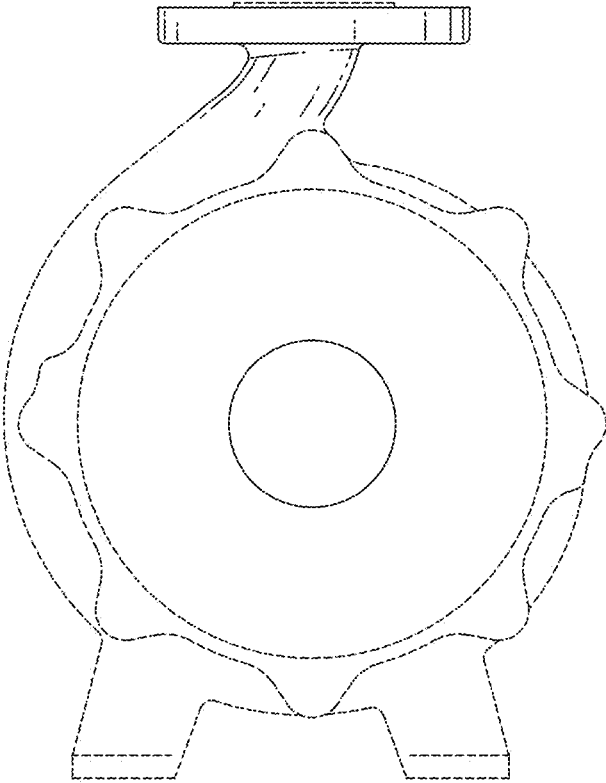

FIG. 52

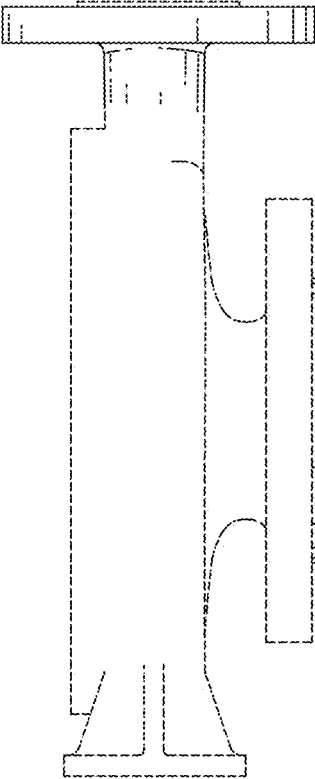

FIG. 53

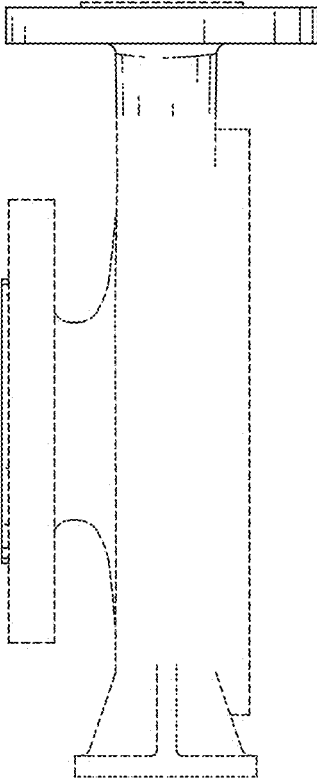

FIG. 54

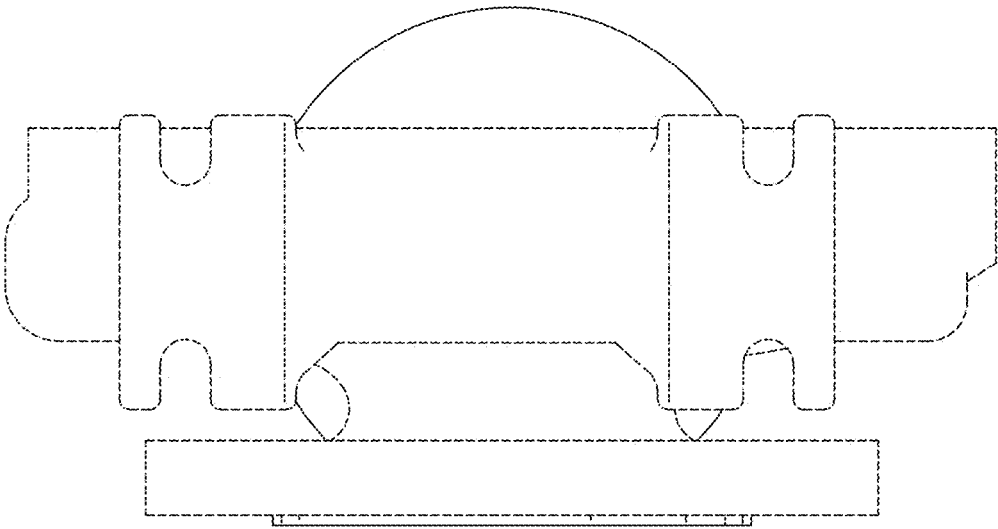

FIG. 55

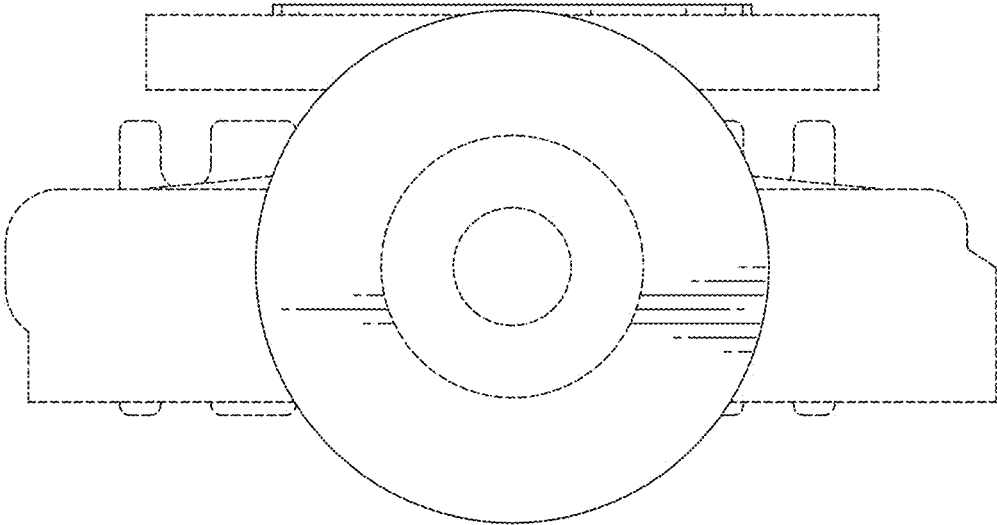

FIG. 56

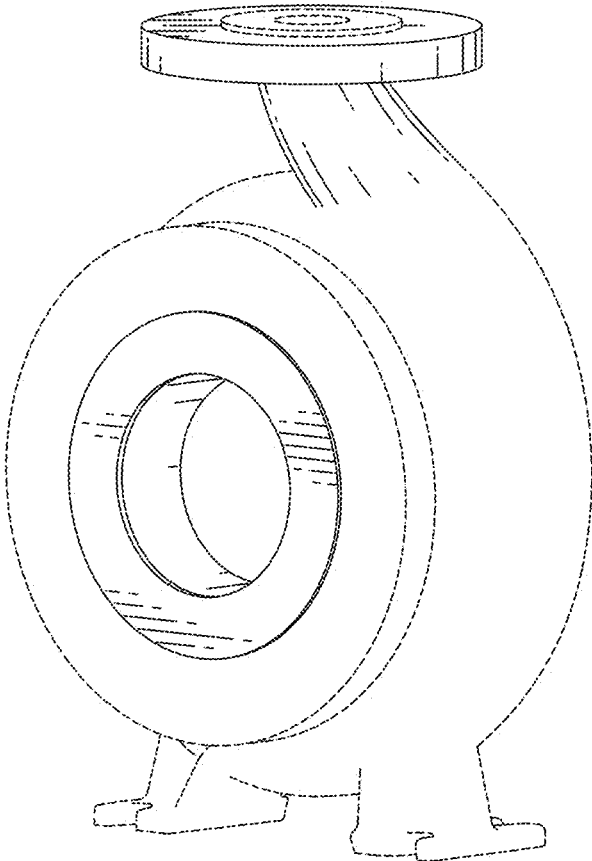

FIG. 57

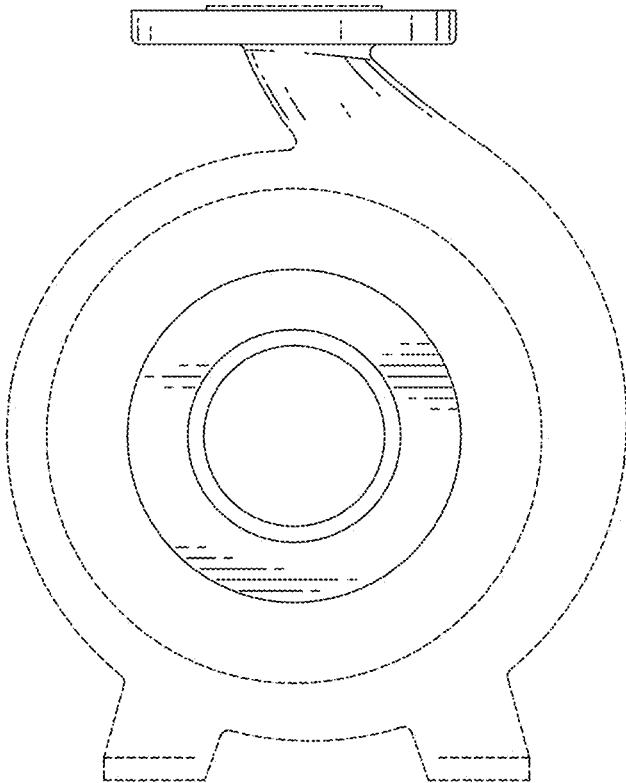

FIG. 58

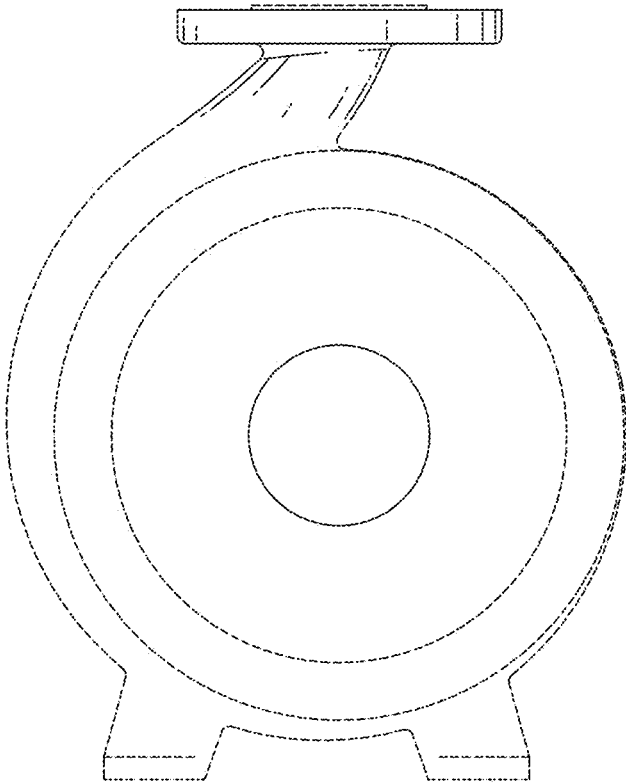

FIG. 59

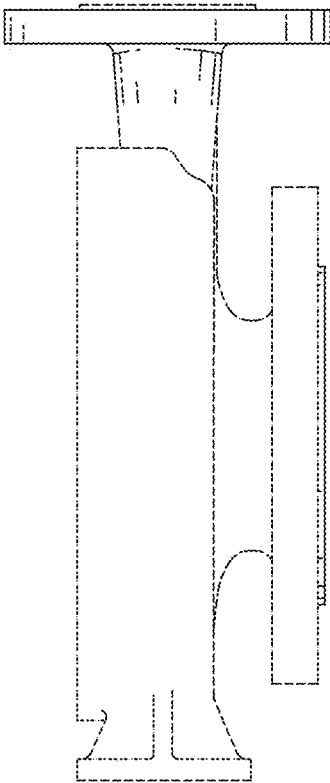

FIG. 60

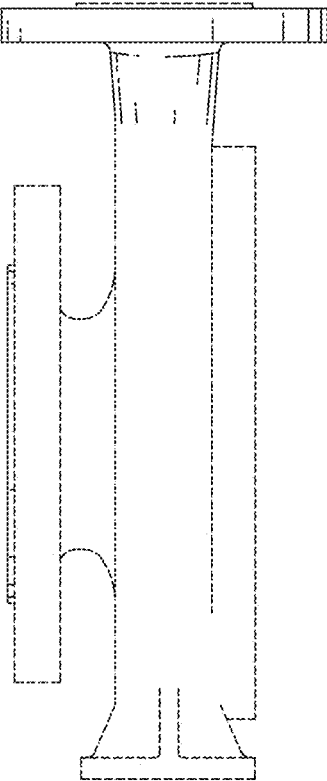

FIG. 61

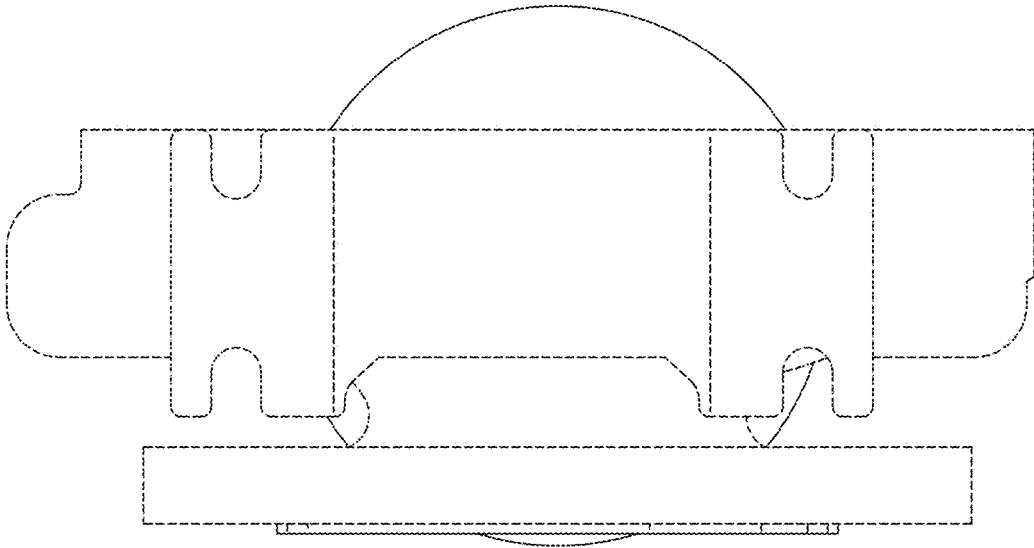

FIG. 62

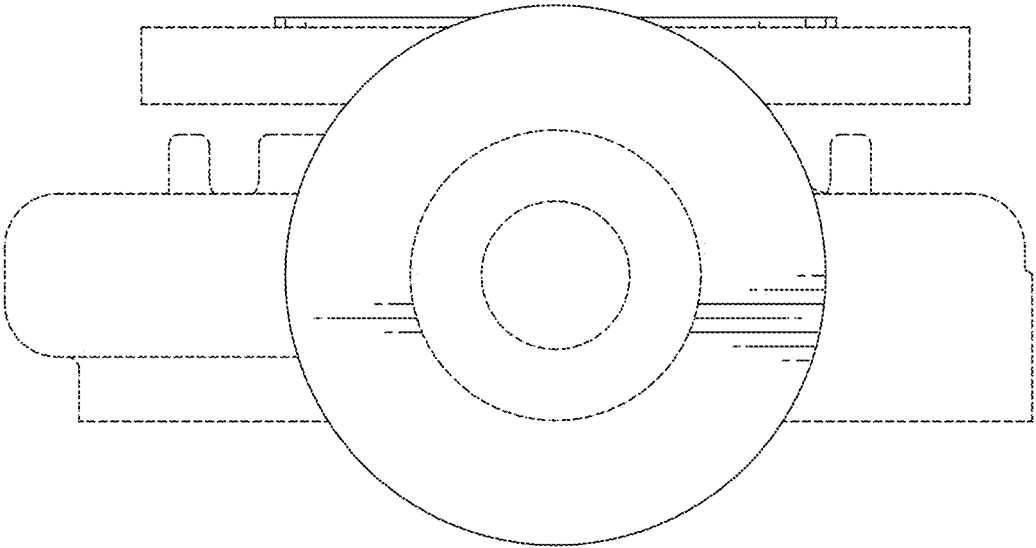

FIG. 63

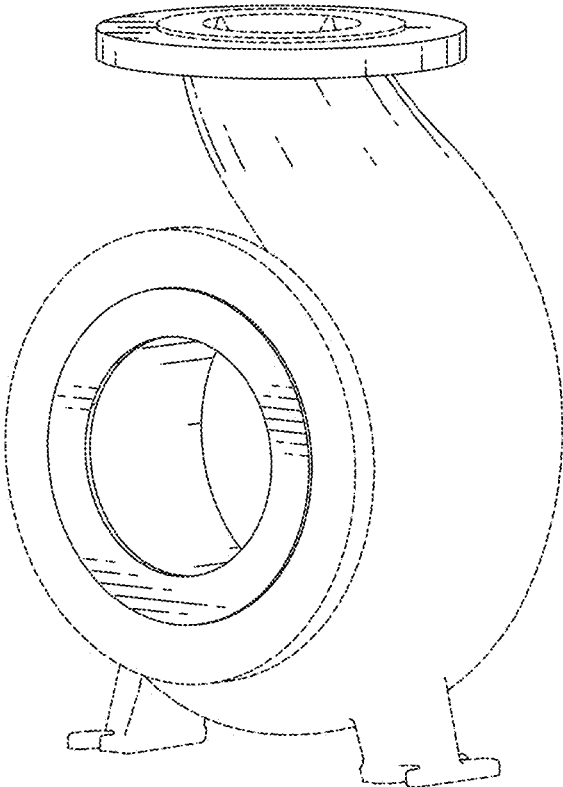

FIG. 64

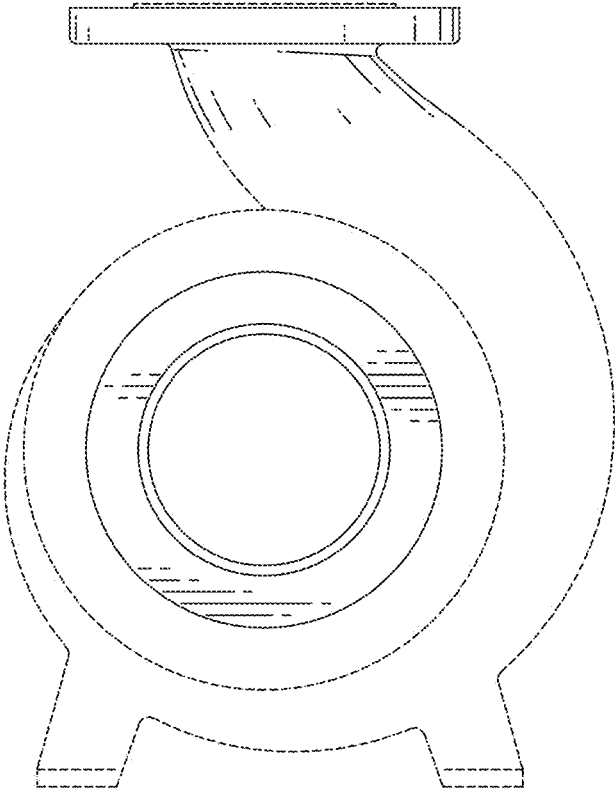

FIG. 65

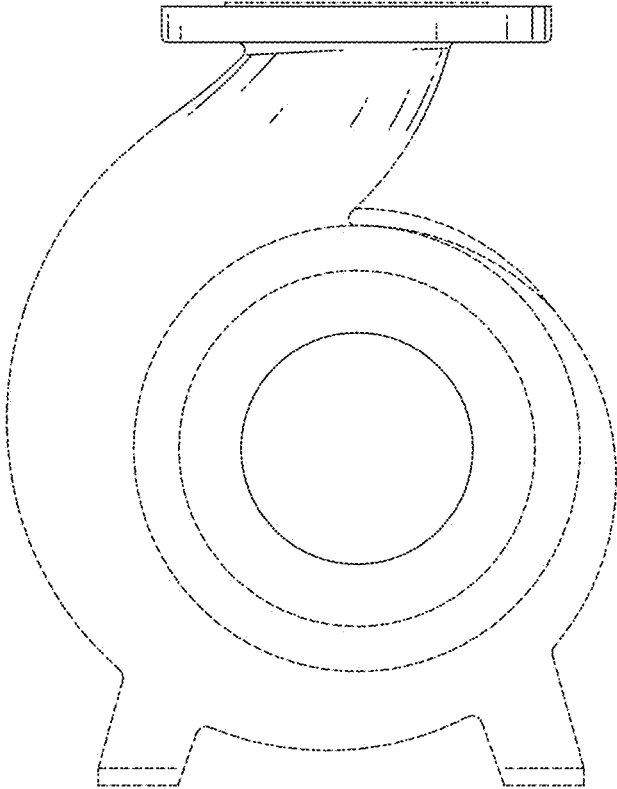

FIG. 66

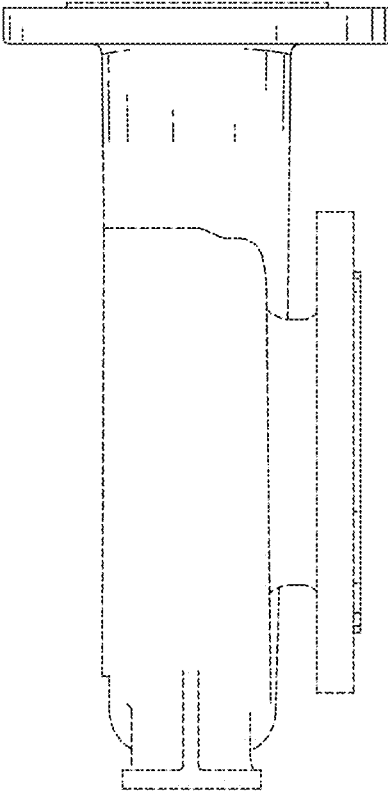

FIG. 67

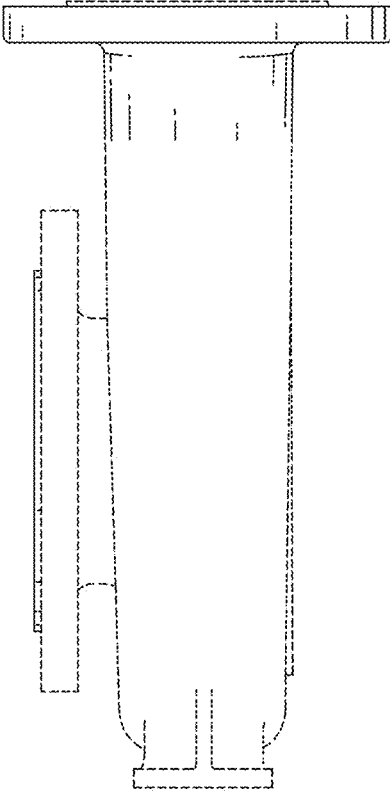

FIG. 68

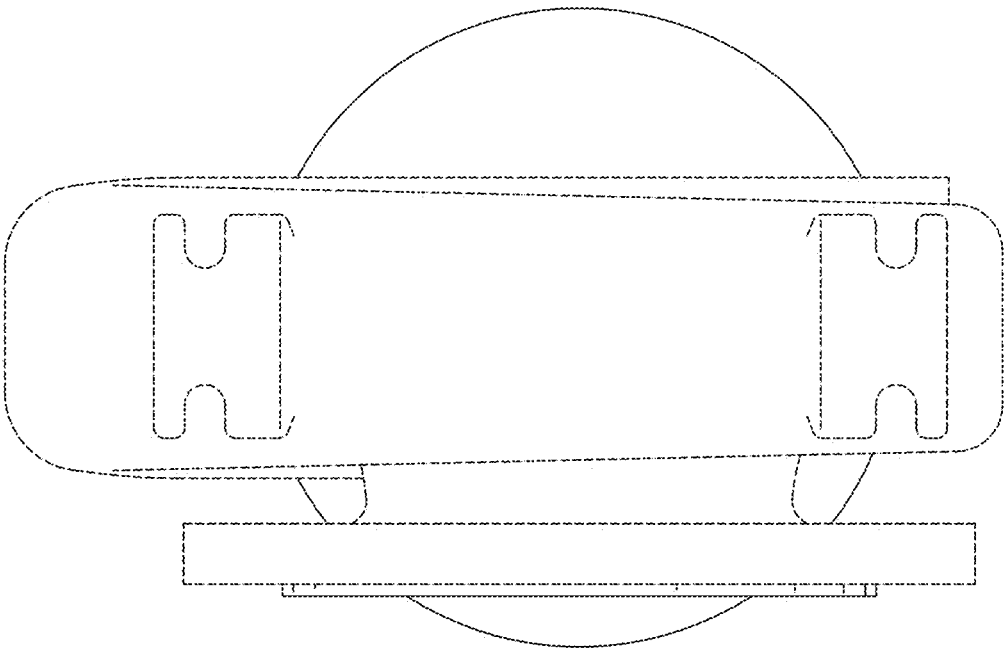

FIG. 69

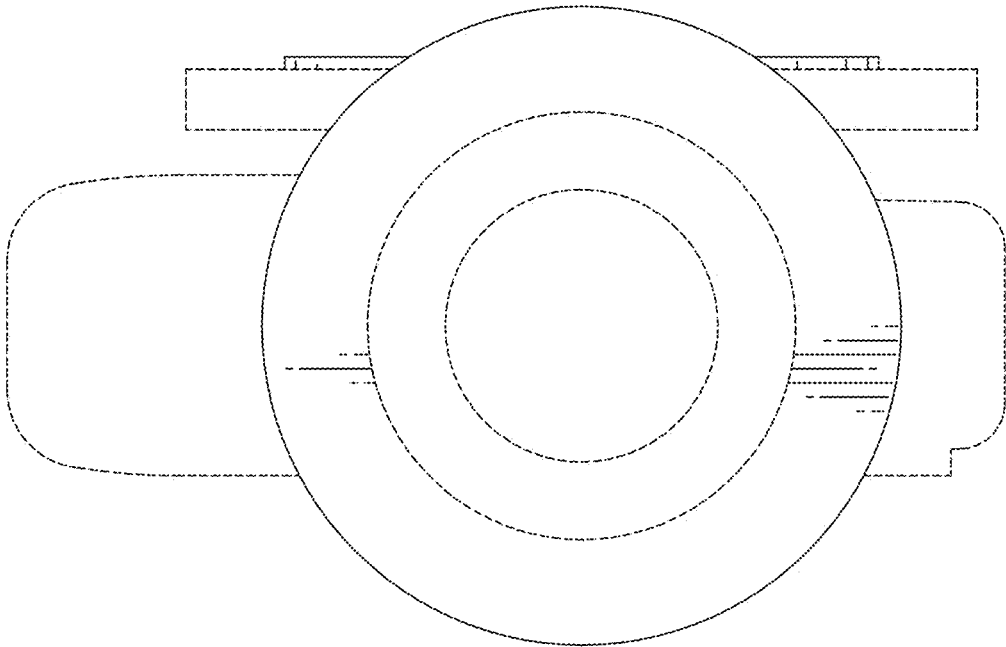

FIG. 70

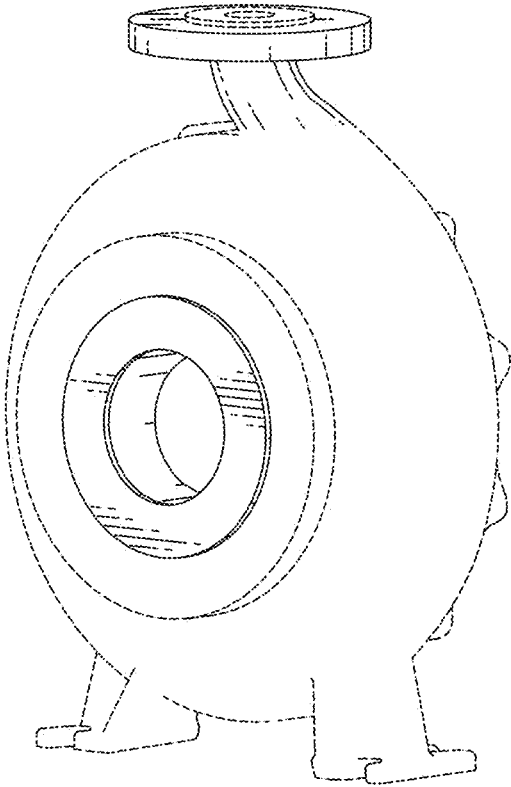

FIG. 71

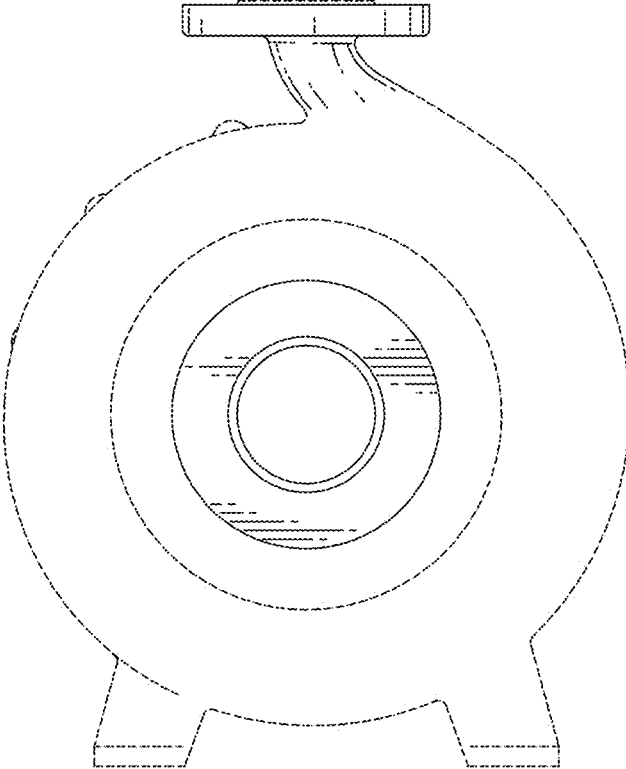

FIG. 72

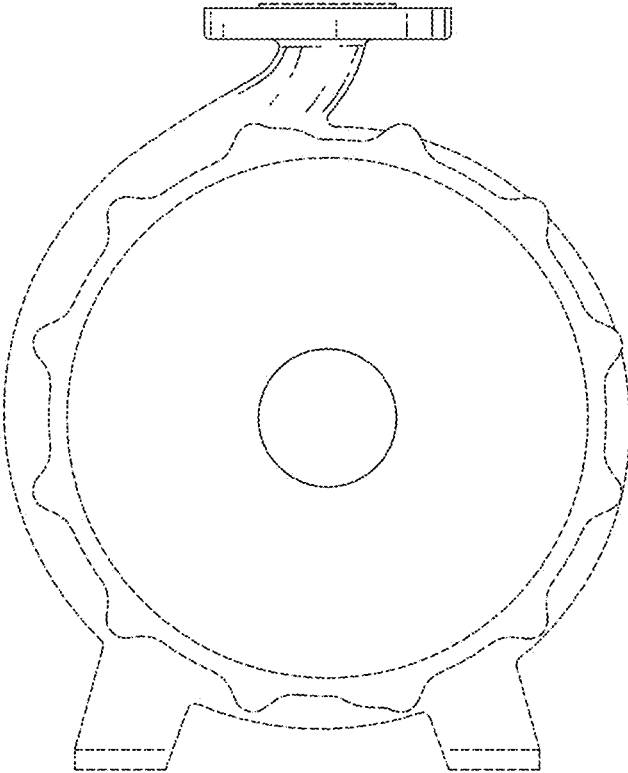

FIG. 73

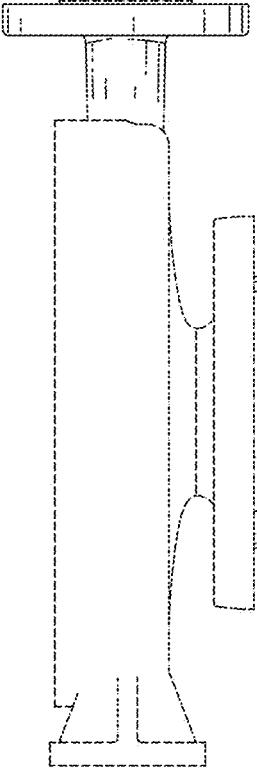

FIG. 74

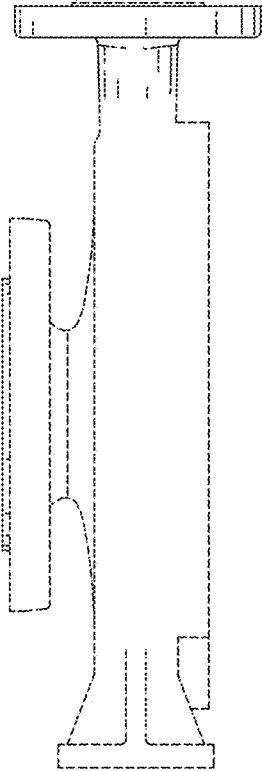

FIG. 75

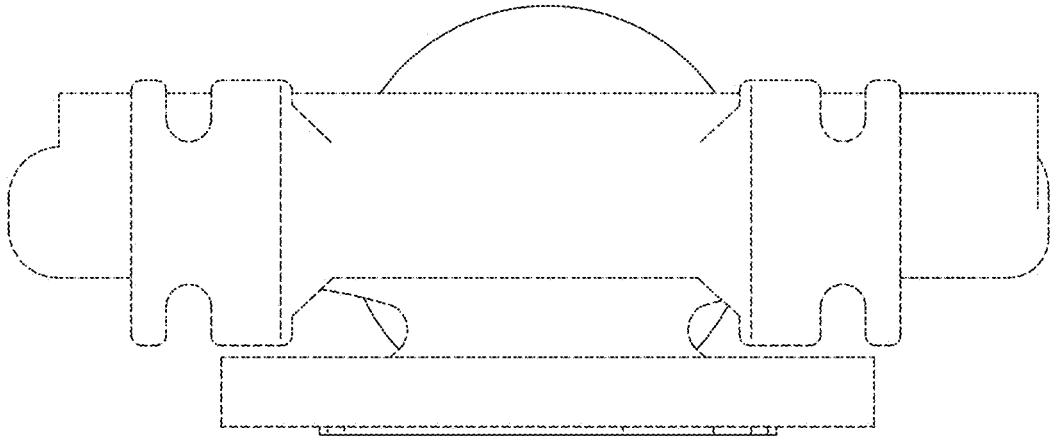

FIG. 76

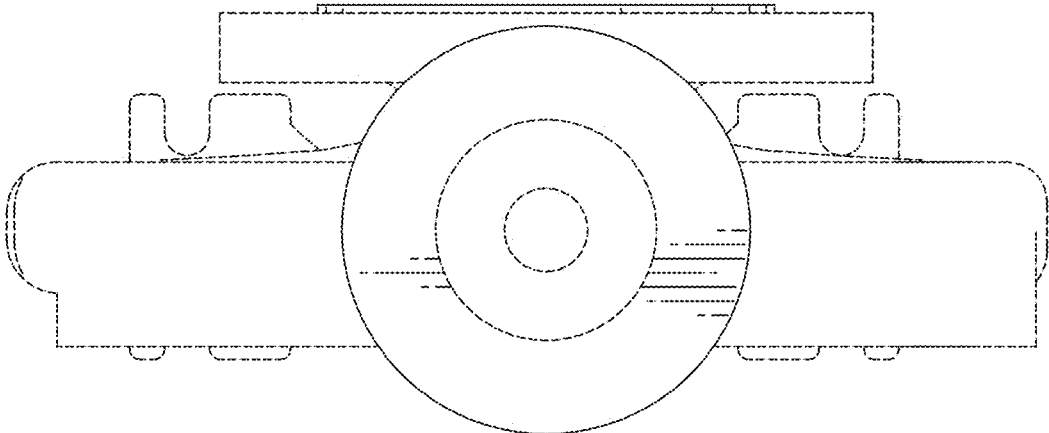

FIG. 77

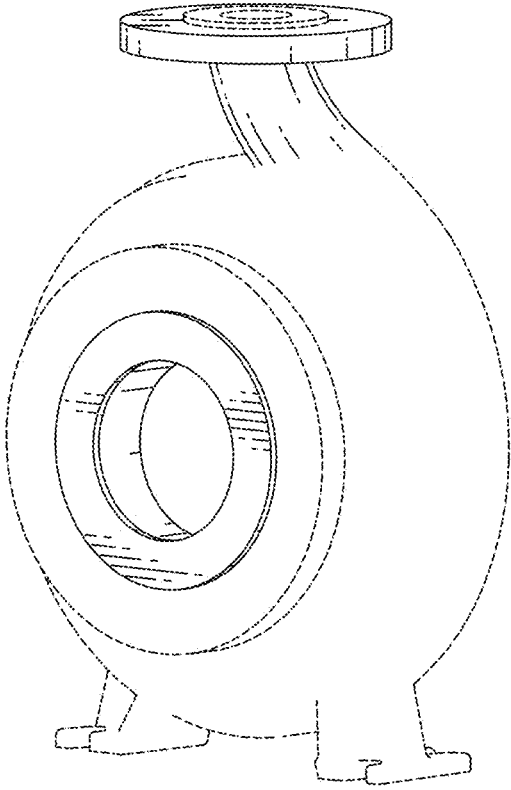

FIG. 78

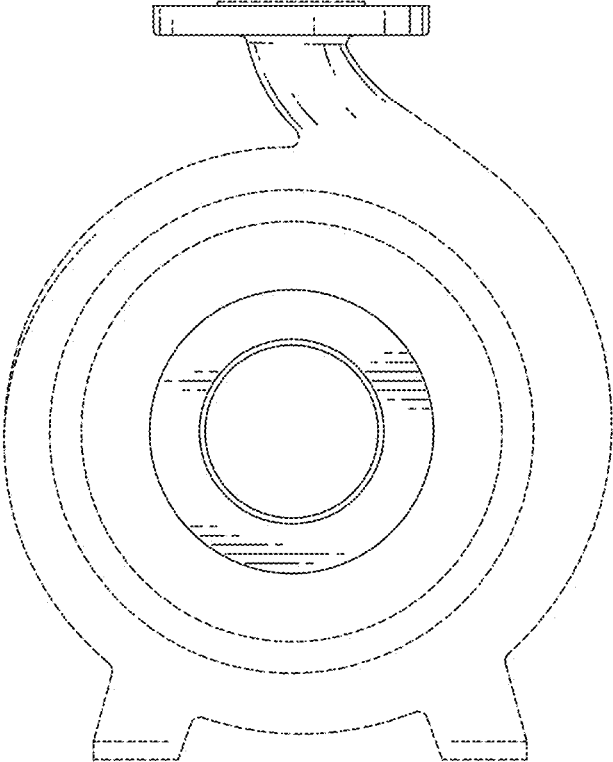

FIG. 79

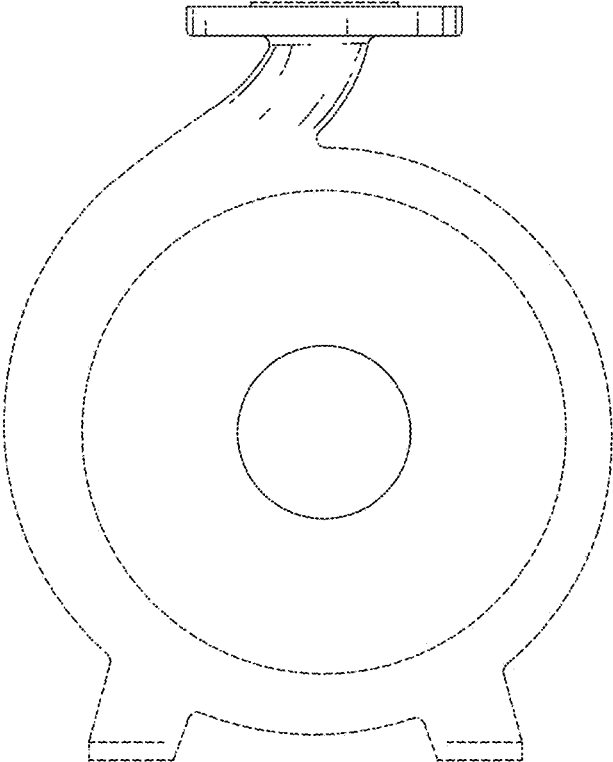

FIG. 80

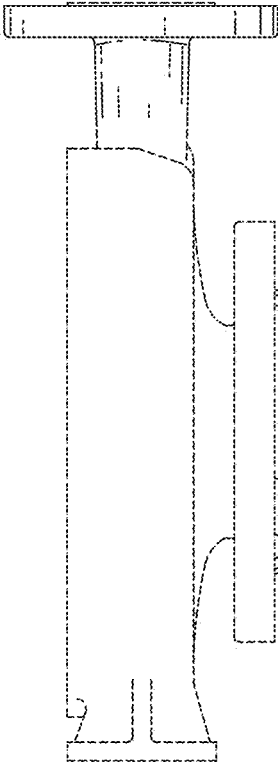

FIG. 81

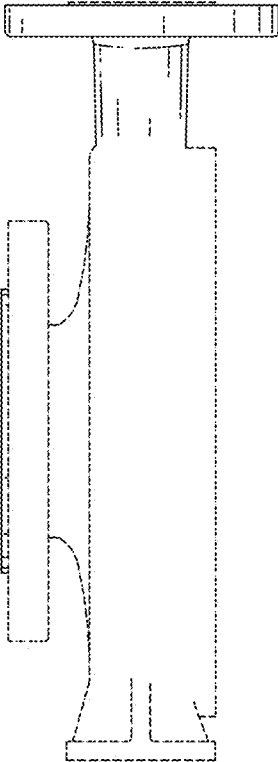

FIG. 82

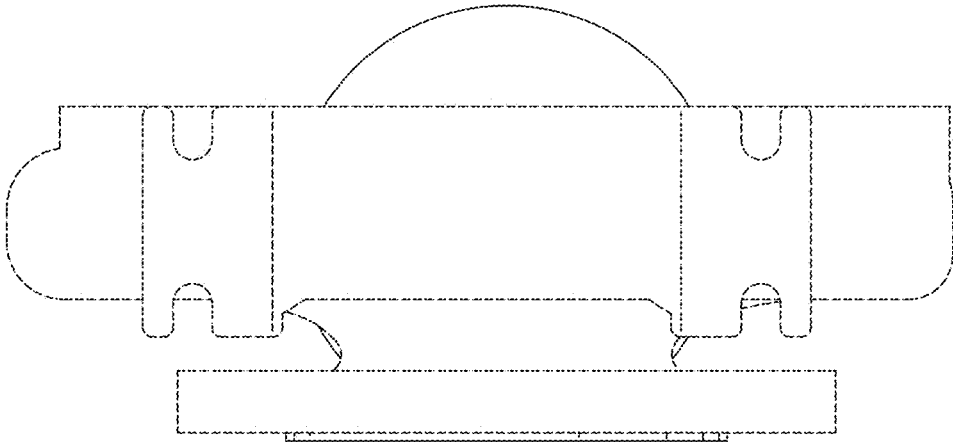

FIG. 83

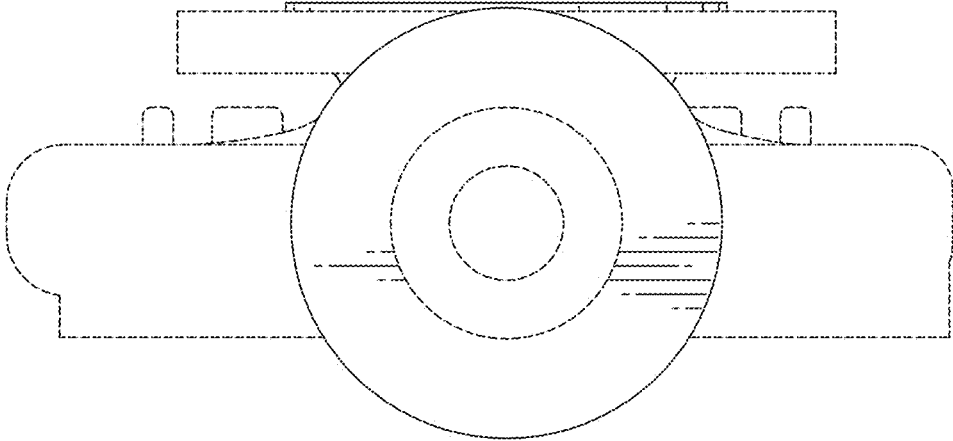

FIG. 84

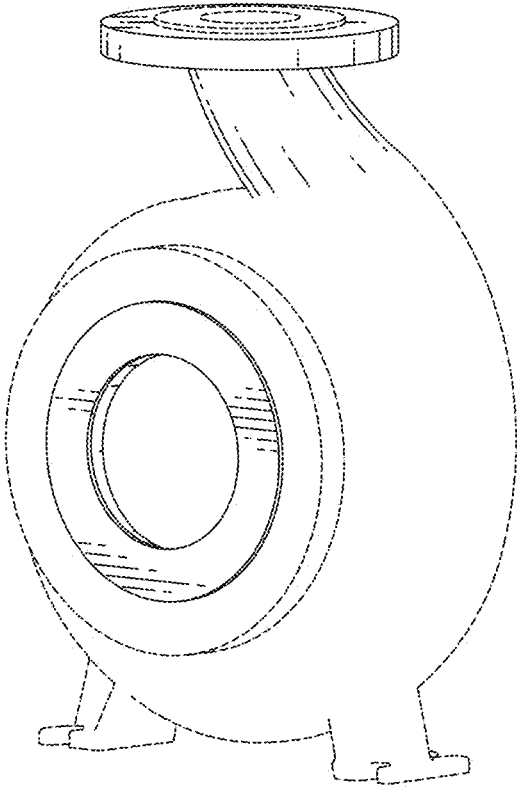

FIG. 85

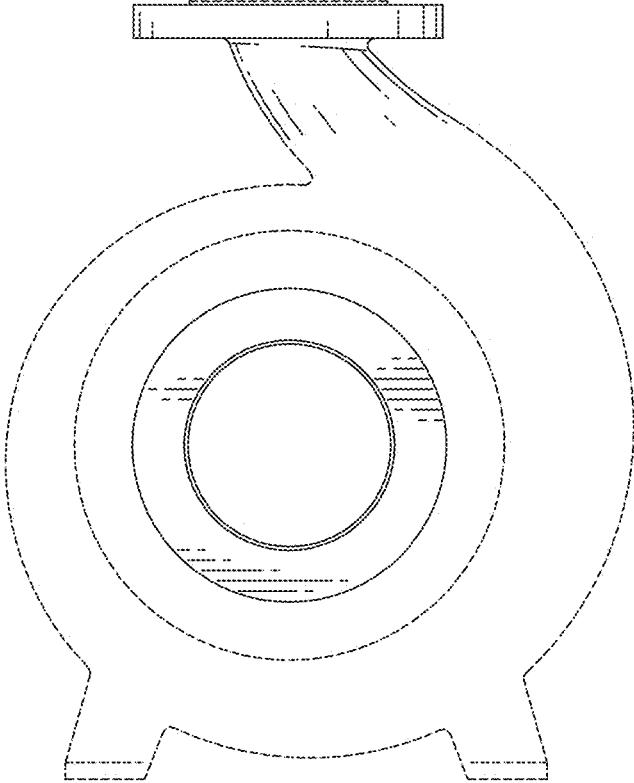

FIG. 86

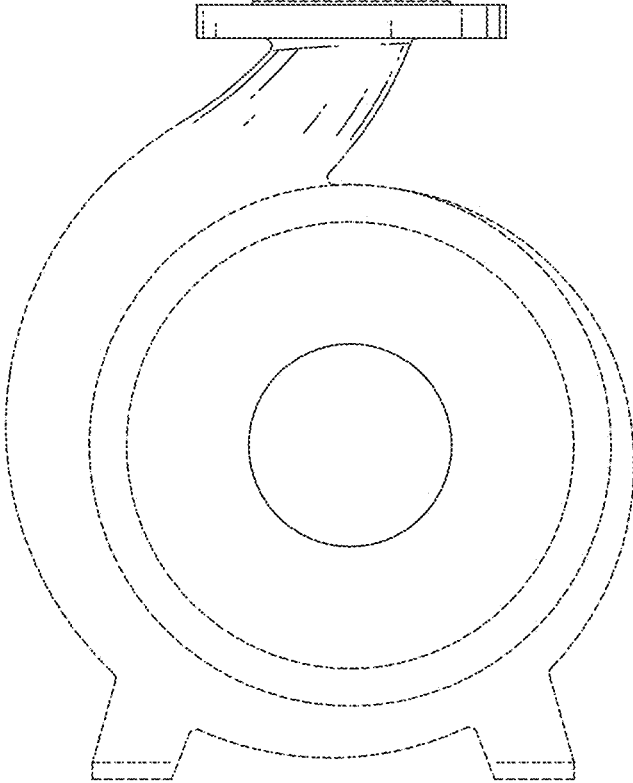

FIG. 87

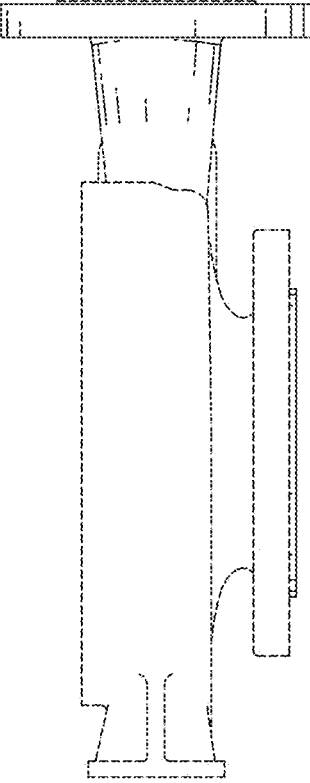

FIG. 88

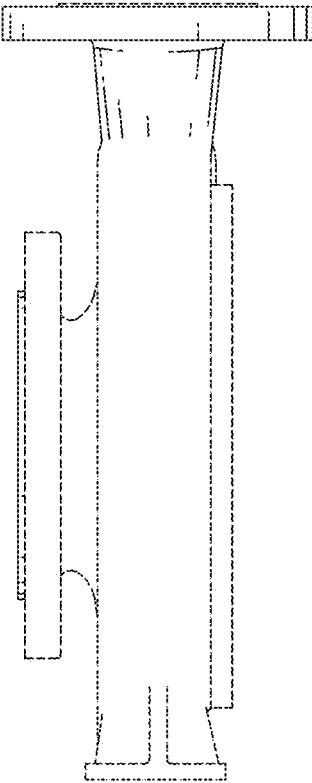

FIG. 89

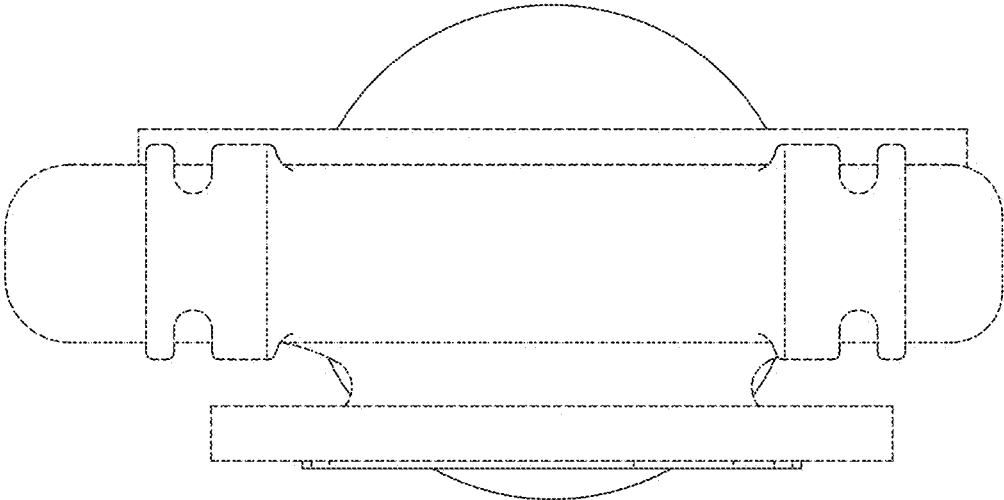

FIG 90

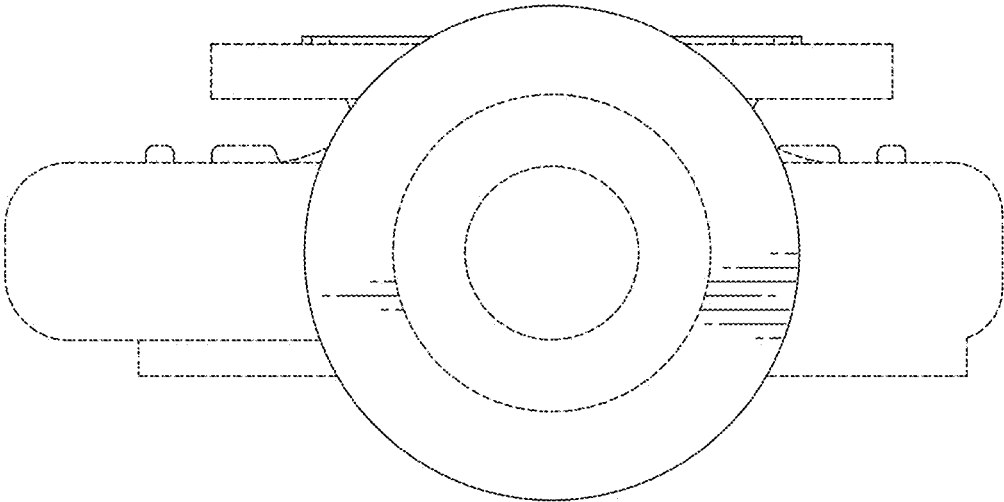

FIG. 91

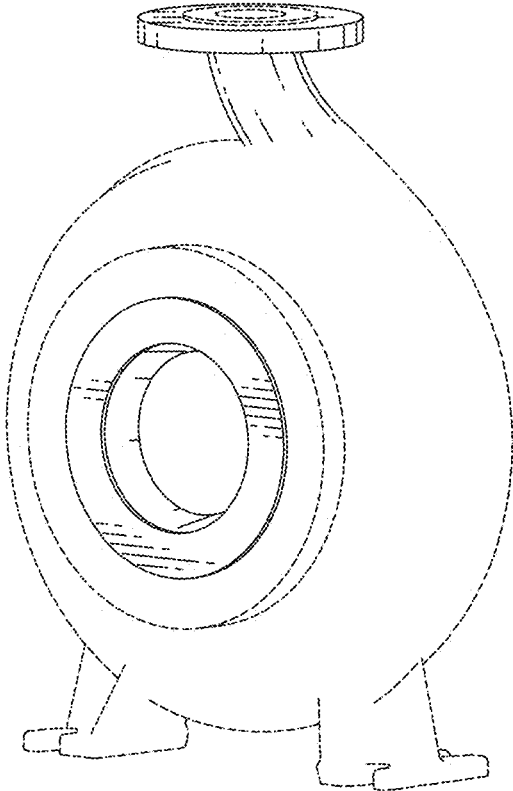

FIG. 92

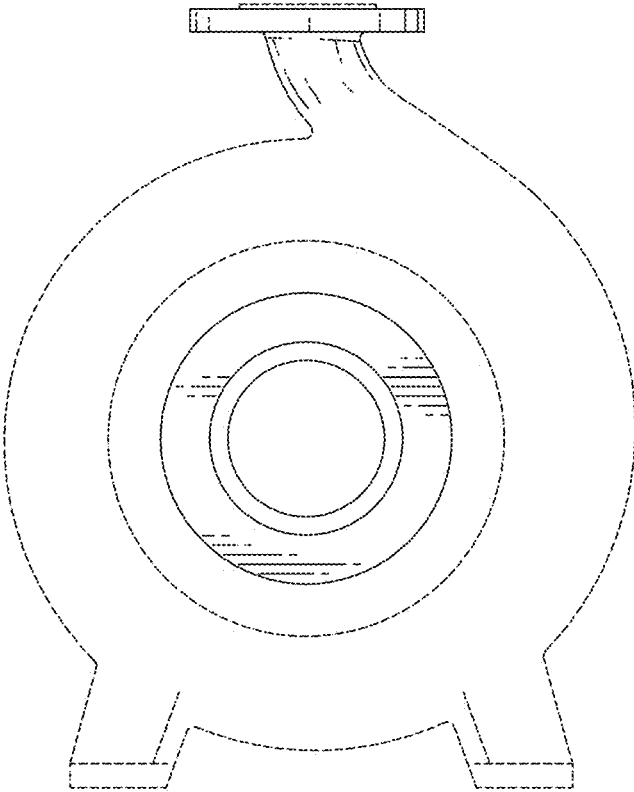

FIG. 93

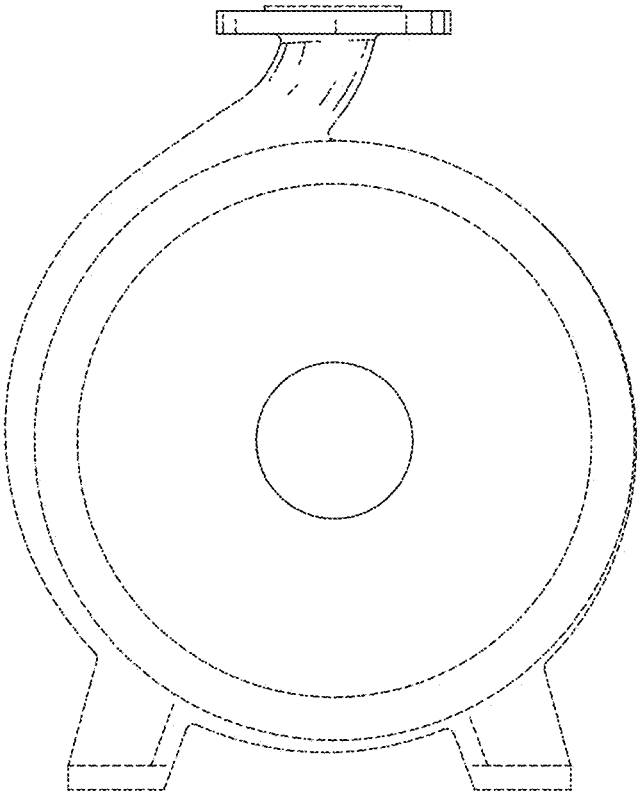

FIG. 94

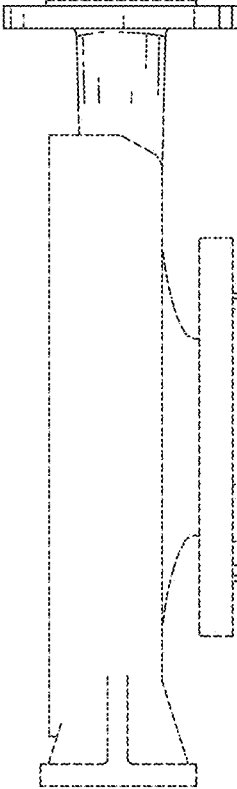

FIG. 95

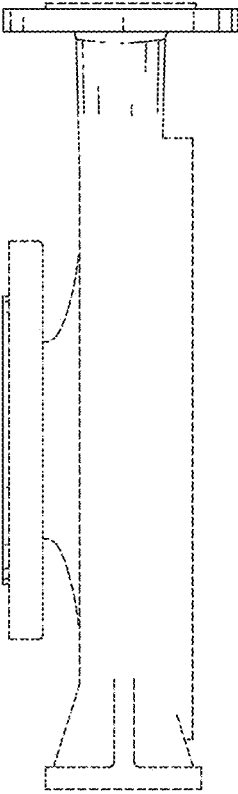

FIG. 96

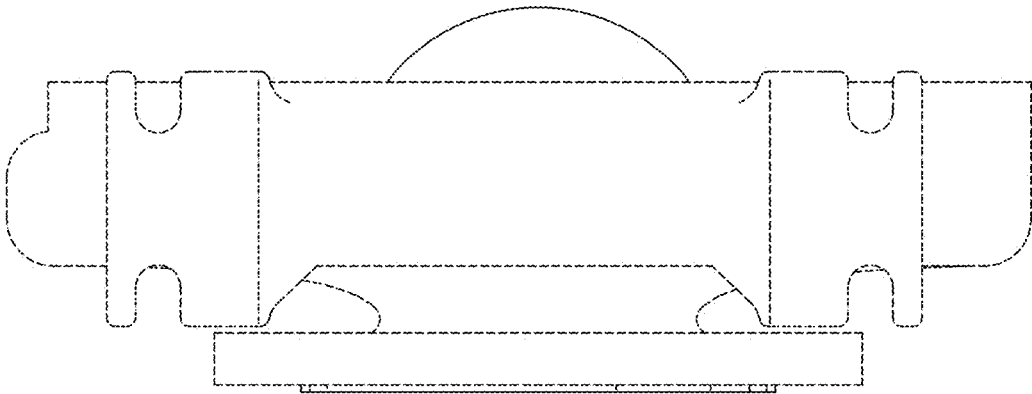

FIG. 97

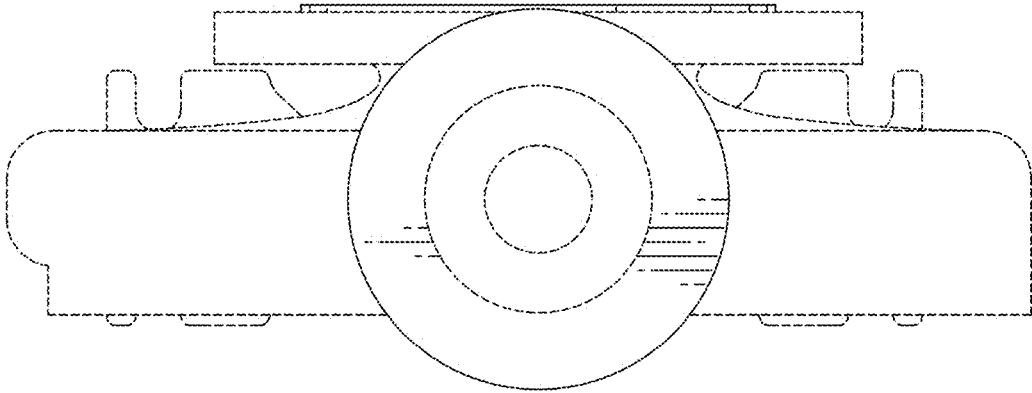

FIG. 98

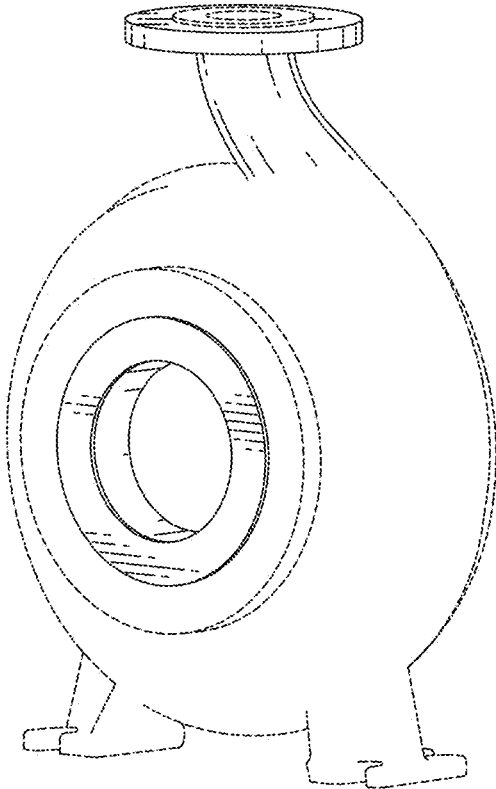

FIG. 99

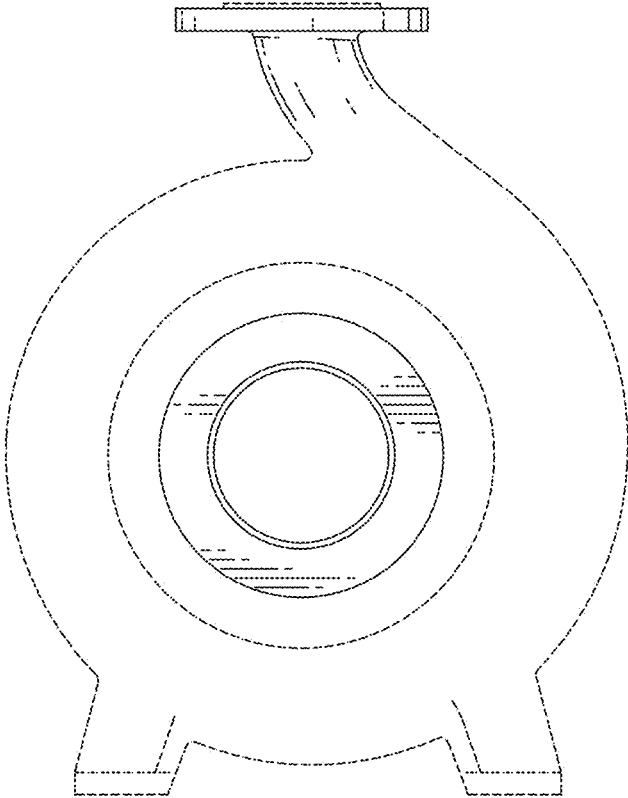

FIG. 100

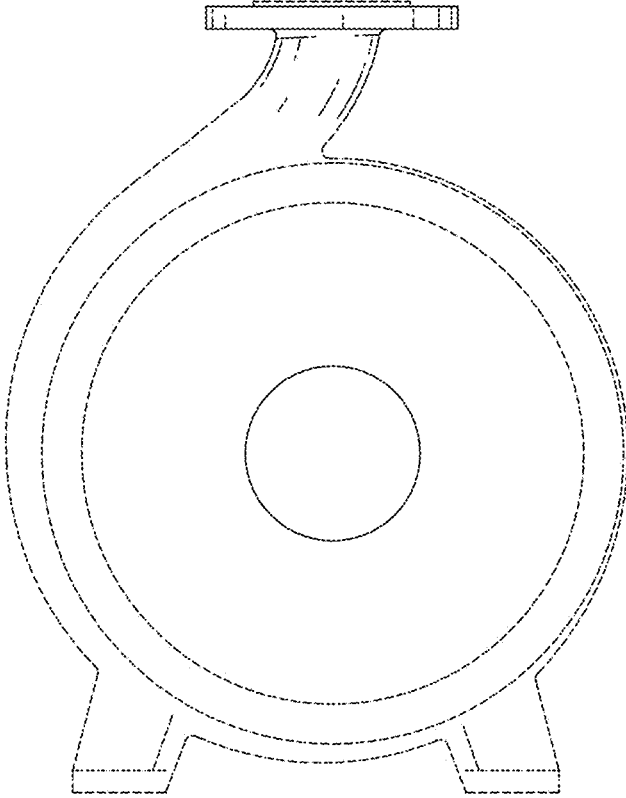

FIG. 101

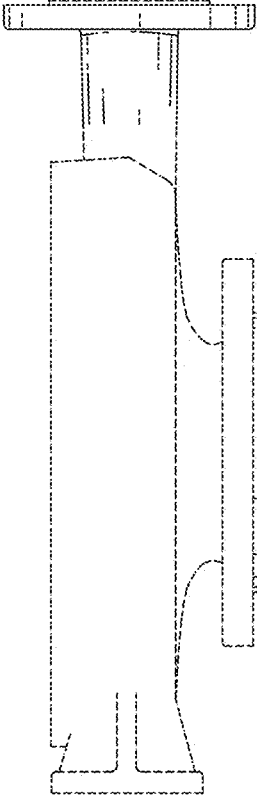

FIG. 102

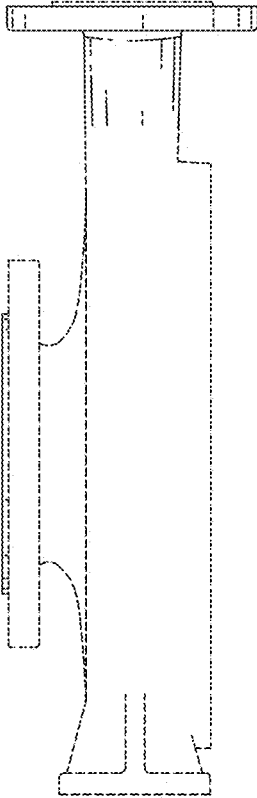

FIG. 103

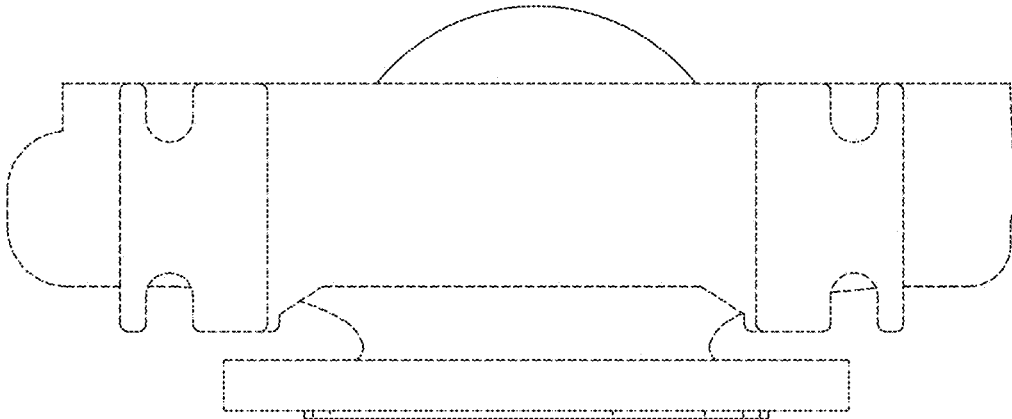

FIG. 104

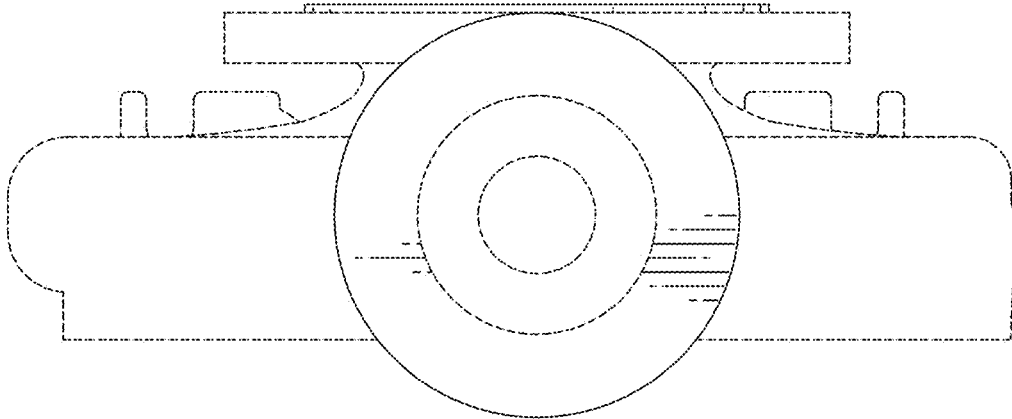

FIG. 105