

(12) PATENT
(19) AUSTRALIAN PATENT OFFICE

(11) Application No. AU 199747222 B2
(10) Patent No. 737064

(54) Title
Trigger type liquid sprayer

(51)⁷ International Patent Classification(s)
B05B 011/00

(21) Application No: **199747222**

(22) Application Date: **1997.10.22**

(87) WIPO No: **WO98/17399**

(30) Priority Data

(31) Number	(32) Date	(33) Country
8-299420	1996.10.22	JP

(43) Publication Date : **1998.05.15**

(43) Publication Journal Date : **1998.07.09**

(44) Accepted Journal Date : **2001.08.09**

(71) Applicant(s)
Yoshino Kogyosho Co., Ltd.

(72) Inventor(s)
Noritoshi Watanabe; Katsuhito Kuwahara; Yoshiyuki Kakuta

(74) Agent/Attorney
DAVIES COLLISON CAVE, 1 Little Collins Street, MELBOURNE VIC 3000

(56) Related Art
JP 9-299838
JP 4-284873



AU9747222

<p>(51) 国際特許分類6 B05B 11/00</p>	<p>A1</p>	<p>(11) 国際公開番号 WO98/17399</p> <p>(43) 国際公開日 1998年4月30日(30.04.98)</p>
------------------------------------	-----------	--

<p>(21) 国際出願番号 PCT/JP97/03817</p> <p>(22) 国際出願日 1997年10月22日(22.10.97)</p> <p>(30) 優先権データ 特願平8/299420 1996年10月22日(22.10.96) JP</p> <p>(71) 出願人 (米国を除くすべての指定国について) 株式会社 吉野工業所 (YOSHINO KOGYOSHO CO., LTD.)(JP/JP) 〒136 東京都江東区大島3丁目2番6号 Tokyo, (JP)</p> <p>(72) 発明者 ; および</p> <p>(75) 発明者 / 出願人 (米国についてののみ) 渡辺記利(WATANABE, Noritoshi)(JP/JP) 桑原和仁(KUWAHARA, Katsuhito)(JP/JP) 角田義幸(KAKUTA, Yoshiyuki)(JP/JP) 〒136 東京都江東区大島3丁目2番6号 株式会社 吉野工業所内 Tokyo, (JP)</p> <p>(74) 代理人 弁理士 市川理吉, 外(ICHIKAWA, Rikichi et al.) 〒104 東京都中央区京橋三丁目1番2号 片倉ビル 市川特許事務所 Tokyo, (JP)</p>	<p>(81) 指定国 AL, AU, BA, BB, BG, BR, CA, CN, CU, CZ, EE, HU, IL, IS, JP, KR, LC, LK, LR, LT, LV, MG, MK, MN, MX, NO, NZ, PL, RO, SG, SI, SK, SL, TR, TT, UA, US, UZ, VN, YU, ARIPO特許 (GH, KE, LS, MW, SD, SZ, UG, ZW), ユーラシア特許 (AM, AZ, BY, KG, KZ, MD, RU, TJ, TM), 欧州特許 (AT, BE, CH, DE, DK, ES, FI, FR, GB, GR, IE, IT, LU, MC, NL, PT, SE), OAPI特許 (BF, BJ, CF, CG, CI, CM, GA, GN, ML, MR, NE, SN, TD, TG).</p> <p>添付公開書類 国際調査報告書</p>
--	---

(54) Title: TRIGGER TYPE LIQUID SPRAYER

(54) 発明の名称 トリガー式液体噴出器

(57) Abstract

A trigger type liquid sprayer comprises a mount cylinder (2) fitted onto a neck portion of a container body, a vertical cylinder (2a) provided upright on the mount cylinder (2), a jetting cylinder (3) projecting forward from an upper end of the vertical cylinder (2a), a cylinder (4) projecting forward from an intermediate portion of the vertical cylinder (2a), a plunger (6) slidably fitted in the cylinder (4) and biased forward, a trigger (5), a rear surface of an upper portion of which engages with a forward end of the plunger (6) and which is swingably mounted to a forward end of the jetting cylinder (3), a nozzle fitting cylinder (7) mounted to a forward end of the jetting cylinder (3), and a nozzle head (8) formed with nozzle holes (10) and rotatably mounted to an outer surface of the nozzle fitting cylinder (7). An arm (21) projects rearward from an outer surface of the nozzle head (8), a first engaging portion (23) is provided on an upper portion of the trigger (5), and a second engaging portion (26) is provided on a forward surface of a lower portion of the cylinder (4). When the trigger (5) is positioned at a foremost location and the nozzle head (8) is turned, a portion of the arm (21) detachably engages with the first engaging portion (23), and the other portion of the arm (21) detachably engages with the second engaging portion (26), whereby the plunger (6) will not move rearward even when a user attempts to pull the trigger (5).

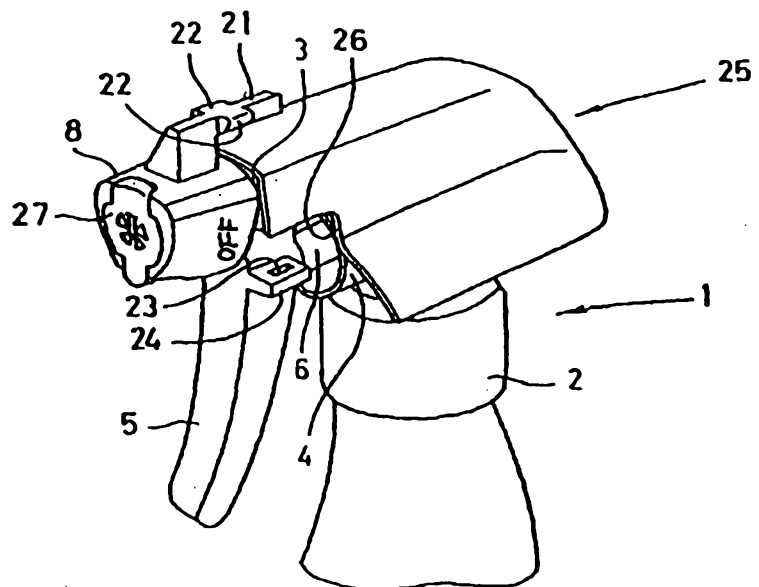

ABSTRACT OF THE DISCLOSURE

A trigger-type liquid dispenser comprises a mounting sleeve (2) to be fitted onto a neck portion of a container body, a vertical sleeve (2a) erected from the mounting sleeve (2), an ejecting sleeve (3) projected forwardly from an upper end portion of the vertical sleeve (2a), a cylinder (4) projected forwardly from a middle portion of the vertical sleeve (2a), a plunger (6) slidably engaged in the cylinder (4) and being urged forwardly, a trigger (5) swingably attached to a front portion of the ejecting sleeve (3), a rear surface of an upper portion of the trigger (5) being engaged with a front end portion of the plunger (6), a nozzle fitting sleeve (7) fitted to a front end portion of the ejecting sleeve (3), and a nozzle head (8) rotatably fitted to an outer surface of the nozzle fitting sleeve (7), said nozzle head (8) being formed with a nozzle hole (10). Liquid stored in the container body is sucked up and ejected through the nozzle hole (10) by pulling the trigger (5) rearwardly. An arm (21) is projected rearwardly from an outer surface of the nozzle head (8). A first engaging portion (23) is provided at an upper portion of the trigger (5). A second engaging portion (26) is provided at a front surface of a lower portion of the cylinder (4). When the trigger (5) is positioned at its front-most position and the nozzle head (8) is rotated, a part of the arm (21) is detachably engaged with the first engaging portion (23), another part of the arm (21) is detachably engaged with the second engaging portion (26), so that the plunger (6) can not move rearwardly even if a user attempts to pull the trigger (5).



Trigger-type Liquid Dispenser

BACKGROUND OF THE INVENTION

The present invention relates to a trigger-type liquid dispenser.

A conventional trigger-type liquid dispenser 1 shown in FIG. 12 comprises a mounting sleeve 2, a vertical sleeve 2a, an ejecting sleeve 3, a cylinder 4, a trigger 5, a plunger 6, a nozzle fitting sleeve 7 and a nozzle head 8. The vertical sleeve 2a is erected from an upper portion of the mounting sleeve 2 to be fitted onto an outer surface of a neck portion of a container body (not shown in FIG. 12). The ejecting sleeve 3 is projected forwardly from an upper end of said vertical sleeve 2a. The trigger 5 is swingably attached to a front portion 30 of said ejecting sleeve 3. The cylinder 4 is projected forwardly from said vertical sleeve 2a. The plunger 6 is arranged in a cylinder 4 and urged forwardly. A front end of the plunger 6 is engaged with a rear surface of an upper portion of said trigger 5. The nozzle head 8 is fitted into a front end of the ejecting sleeve 3 via the nozzle fitting sleeve 7. The nozzle head 8 has a nozzle hole 10. Liquid stored in the cylinder 4 is ejected through the nozzle hole 10 of the nozzle head 8 by pulling the trigger 5. When the trigger 5 is released, the plunger 6 is moved or returned forwardly, thereby returning the trigger 5 to its initial position, so as to suck up the liquid within the container body into the cylinder 4. Numeral 27 designates a cover plate which blocks the front surface of the nozzle head 8 openably.

In said trigger-type liquid dispenser, since liquid is



ejected even if the trigger 5 is pulled inadvertently, a liquid discharge passage 11 in the nozzle head 8 and the nozzle fitting sleeve 7 fitted into the front end of the ejecting sleeve 3 is divided into a front portion 11b and a rear portion 11a. When the nozzle head 8 is rotated relative to the nozzle fitting sleeve 7, the nozzle head, the communication of said liquid discharge passage 11 is shut off. Liquid can be ejected only when the nozzle head is returned to its initial position.

Even if the liquid discharge passage is closed or shut by rotating the nozzle head 8 relative to the nozzle fitting sleeve 7, when the trigger 5 is pulled many times, the plunger 6 moves forwardly or backwardly a little due to the deflection or elastic restoration. Thus, high pressure liquid may accumulate in the front portion of the ejecting sleeve 3 between said discharge nozzle and the liquid discharge passage formed by said nozzle fitting sleeve 7 due to the abnormal high pressure in the cylinder. In this condition, when said nozzle head 8 is rotated to open the liquid discharge passage, high pressure liquid accumulated in the front portion of the ejecting sleeve 3 may happen to be discharged through the nozzle hole without operating the trigger 5. There is also the danger that the nozzle head 8 may be disconnected due to high pressure in the ejecting sleeve 3 when the trigger 5 is pulled strongly.

SUMMARY OF THE INVENTION

The present invention solves the above-described defects by

The present invention provides a trigger-type liquid dispenser comprising;

a mounting sleeve (2) to be fitted onto a neck portion of a



container body,

a vertical sleeve (2a) erected from the mounting sleeve (2),

an ejecting sleeve (3) projected forwardly from an upper end portion of the vertical sleeve (2a),

a cylinder (4) projected forwardly from a middle portion of the vertical sleeve (2a),

a plunger (6) slidably engaged in the cylinder (4), said plunger (6) being urged forwardly,

a trigger (5) swingably attached to a front portion of the ejecting sleeve (3), a rear surface of an upper portion of the trigger (5) being engaged with an front end portion of the plunger (6),

a nozzle fitting sleeve (7) fitted to a front end portion of the ejecting sleeve (3), and

a nozzle head (8) rotatably fitted to an outer surface of the nozzle fitting sleeve (7), said nozzle head (8) being formed with a nozzle hole (10),

wherein liquid stored in the container body is sucked up and ejected through the nozzle hole (10) by pulling the trigger (5) rearwardly,

characterized in that

an arm (21) is projected rearwardly from an outer surface of the nozzle head (8),

a first engaging portion (23) is provided at an upper portion of the trigger (5),

a second engaging portion (26) is provided at a front surface of a lower portion of the cylinder (4), and

when the trigger (5) is positioned at its front-most



position and the nozzle head (8) is rotated, a part of the arm (21) is detachably engaged with the first engaging portion (23), another part of the arm (21) is detachably engaged with the second engaging portion (26), so that the plunger (6) can not move rearwardly even if a user attempts to pull the trigger (5).

A surrounding sleeve (29) may be unrotatably engaged with an outer surface of the nozzle head (8), and an arm (21) is rearwardly projected from the surrounding sleeve (29). In other words, the arm 21 may be indirectly projected rearwardly from an outer surface of the nozzle head (8).

The second aspect of the invention provides a trigger-type liquid dispenser, wherein

an engaging plate (24) is formed on and projected from a side surface of an upper portion of the trigger (5),

the engaging plate (24) is formed with a through-hole which is bored perpendicularly and acts as the first engaging portion (23),

a first engaging projection piece (22) is formed and projected from a middle portion of the arm (21), and

the first engaging projection piece (22) is engagable with the through-hole of the engaging plate (24).

In this case, the trigger-type liquid dispenser may have a body cover 25 which has the front end surface. The front end surface acts as a second engaging portion 26.

The third aspect of the invention provides a trigger-type liquid dispenser, wherein

a rear surface of an upper portion of the trigger (5) acts as the first engaging portion (23),



a front surface of a lower portion of the cylinder (4) acts as the second engaging portion (26),

a second engaging projection piece (28) is projected sideward and outward from a rear portion of the arm (21), and

the second engaging projection piece (28) is positioned or engaged between the first engaging portion (23) and the second engaging portion (26).

BRIEF DESCRIPTION OF THE DRAWING

FIG. 1 is a perspective view of the liquid dispenser according to the first embodiment of the present invention.

FIG. 2 is a front view of the liquid dispenser of FIG. 1.

FIG. 3 is a front view of the liquid dispenser of FIG. 1, illustrating the locking state.

FIG. 4 is a perspective view of the liquid dispenser of FIG. 3.

FIG. 5 is a side view of the liquid dispenser of FIG. 3.

FIG. 6 is a perspective view of the liquid dispenser according to the second embodiment of the present invention.

FIG. 7 is a perspective view of the liquid dispenser of FIG. 6, illustrating the locking state.

FIG. 8 is a front view of the liquid dispenser of FIG. 7.

FIG. 9 is a side view of the liquid dispenser of FIG. 7.

FIG. 10 is a partially exploded perspective view of the liquid dispenser according to the third embodiment of the present invention.

FIG. 11 is a perspective view of the liquid dispenser of FIG. 10.

FIG. 12 is a sectional view of a conventional liquid



dispenser.

PREFERRED EMBODIMENT OF THE INVENTION

Numeral 1 designates a generally used trigger-type liquid dispenser, which is described in conjunction with FIG. 12. The trigger-type liquid dispenser 1 shown in FIG. 12 comprises a mounting sleeve 2, a vertical sleeve 2a, an ejecting sleeve 3, a cylinder 4, a trigger 5, a plunger 6, a nozzle fitting sleeve 7 and a nozzle head 8. The vertical sleeve 2a is erected from an upper portion of the mounting sleeve 2 to be screwed onto an outer surface of a neck portion of a container body (partially illustrated in FIGS. 1-11). The ejecting sleeve 3 is projected forwardly from the upper end of said vertical sleeve 2a. The cylinder 4 is projected forwardly from the front surface of the middle portion of the vertical sleeve 2a. The trigger 5 is swingably attached to the front portion 30 of said ejecting sleeve 3 at the upper end portion thereof, and is depended obliquely downwardly and forwardly. The plunger 6 is arranged in the cylinder 4 and is urged forwardly. The front end of the plunger 6 is engaged with the back surface of the upper portion of the trigger 5. Liquid within the cylinder 4 is ejected through the ejecting sleeve 3 by pulling said trigger 5. When the trigger is returned, liquid within the container body is sucked into the cylinder 4 due to negative pressure in the cylinder 4 produced by the return of the trigger 5.

The nozzle head 8 is fitted to the front portion of said ejecting sleeve 3 via the nozzle fitting sleeve 7. The nozzle head 8 and the nozzle fitting sleeve 7 are provided with a liquid discharge passage 11 which communicates the ejecting sleeve 3



with a nozzle hole 10 bored in the center of a front wall 9 of the nozzle head 8. The nozzle fitting sleeve 7 has a base plate 7a and a valve rod 7b projecting from the central portion of the base plate 7a. The nozzle head 8 has the front wall 9 as described above, and has a fitting sleeve 12 projected backwardly from the center of the front wall 9. The fitting sleeve 12 is fitted onto an outer surface of the valve rod 7b water-tightly. As illustrated, said liquid discharge passage 11 is formed in the outer surface of the valve rod 7b and in the inner surface of the fitting sleeve 12. That is, said liquid discharge passage 11 comprises a first discharge passage 11a formed longitudinally (in the axial direction of the sleeve) in the inner surface of the rear portion of the fitting sleeve 12 and a second discharge passage 11b formed in the generatrix direction in the outer surface of the front portion of the valve rod 7b. When the nozzle head 8 is rotated relative to the nozzle fitting sleeve 7 from the communicated condition illustrated in FIG. 12, the first discharge passage 11a is displaced to a different position of the valve rod so that the communication with the second discharge passage 11b is shut off. When the nozzle head 8 is returned to its initial position, the communication is restored again as illustrated in FIG. 12. The above-described construction of the present invention is publicly known and is same as that of FIG. 12.

In the following, the present invention will be described in detail.

In the first embodiment illustrated in FIG. 1 to FIG. 5, an arm 21 is formed and projected directly from an outer surface of



the nozzle head 8. A first engaging projection piece 22 is projected from the middle portion of the arm 21 in a direction of circumference of the nozzle head 8. An engaging plate 24 is formed and projected from the side surface of the upper portion of the trigger 5. The engaging plate 24 is formed with a through-hole which is bored perpendicularly and corresponds to a locus that the first engaging projection piece 22 rotates around an axis of the nozzle head 8. The through-hole acts as a first engaging portion 23. In the illustrated embodiment, the trigger-type liquid dispenser has a body cover 25 which covers the vertical sleeve 2a, the ejecting sleeve 3 and the cylinder 4, and which has the front end surface. The front end surface acts as a second engaging portion 26. The second engaging portion 26 may be formed in the front surface of the cylinder 4. When the nozzle head 8 is rotated so that the first engaging projection piece 22 is inserted into and engaged with the first engaging portion 23, and the rear end surface of the arm 21 is engaged with the second engaging portion 26 of the body cover 25. Thus, even if the user attempts to pull the trigger 5 under such condition, the trigger 5 can not move.

In the illustrated example, two first engaging projection pieces 22, 22 are projected from left and right of the middle portion of the arm 21, and two engaging plates 24 with through-holes are projected from left and right of the upper portion of the trigger 5. However, only one first engaging projection piece 22 and only one engaging plate 24 may be provided, in other words, the present invention is not limited to two first engaging projection pieces and two engaging plates. When the arm 21 is



positioned on the upper side of the nozzle head 8 as illustrated in FIG. 1, the first and the second liquid discharge passages 11a and 11b are communicated with each other as illustrated in FIG. 12, and liquid can be ejected or dispensed by erecting a cover plate 27 and pulling the trigger 5. When the nozzle head 8 is rotated so that the first engaging projection piece 22 of the arm 21 is engaged into the through-hole of the first engaging portion 23 and the rear end surface of the arm 21 is engaged with the second engaging portion 26 formed on the front surface of the body cover 25, the communication between the first and the second liquid discharge passages 11a and 11b is shut off.

In the second embodiment illustrated in FIG. 6 to FIG. 9, an arm 21 is projected backwardly via a sideward overhang 21a, and a second engaging projection piece 28 is projected sidewardly and outwardly from the rear portion of said arm 21. The rear surface of the upper portion of the trigger 5 acts as a first engaging portion 23. The front surface of the lower portion of cylinder 4 acts as a second engaging portion 26. When the nozzle head 8 is rotated as illustrated in FIGS. 7, 8 and 9, the second engaging projection piece 28 is positioned between the first engaging portion 23 and the second engaging portion 26 and engaged with them. Thus, even if the user attempts to pull the trigger 5 under such condition, the trigger 5 can not move so that the plunger 6 can not move backwardly, and the first and second liquid discharge passages 11a and 11b are shut off.

In the third embodiment illustrated in FIG. 10 and FIG. 11, a surrounding sleeve 29 is unrotatably engaged with the outer surface of the nozzle head 8. An arm 21 is projected backwardly



via an overhang 21a. Also, a second engaging projection piece 28 is projected from the end portion of the arm 21. When the nozzle head 8 is rotated, the second engaging projection piece 28 is positioned between the first engaging portion 22 (the rear surface of the upper portion of the trigger 5) and the second engaging portion 26 (the front surface of the lower portion of cylinder 4) and engaged with them, and the first and second liquid discharge passages 11a and 11b do not communicate each other. When the nozzle head 8 is further rotated with the surrounding sleeve 29 so as to further move the arm 21, the first and second liquid discharge passages 11a and 11b communicate each other like the condition illustrated in FIG. 12.

In the first embodiment as described above, the arm 21 is projected directly from the nozzle head 8. However, in the first embodiment, the arm 21 may be projected indirectly like the third embodiment. In other words, in the first embodiment, the nozzle head 8 may be unrotatably fitted with the surrounding sleeve 29 which has the arm 21. The third embodiment can be recognized as a modification of the second embodiment in which the arm 21 is indirectly projected.

The above described explanation relates to the trigger-type liquid dispenser having an open and shut (close) mechanism of the liquid discharge passage 11 (11a and 11b). However, if the trigger locking mechanism (the arm 21) as described above is provided, such open and shut mechanism is not necessary, because the liquid is not dispensed by the arm 21.

Since the first aspect of the present invention provides a trigger-type liquid dispenser as described above, there is no



danger that the trigger is deflected so that the plunger is thereby retracted when the user attempts to pull the trigger, as in said conventional example, and therefore, liquid leakage and the like can be perfectly prevented.

According to the second aspect of the present invention as described above, the engagement and disengagement of the first engaging projection piece 22 with the first engaging portion 23 and the rear surface of the arm with the second engaging portion 23 and the rear surface of the arm with the second engaging portion 26 can be easily carried out.

According to the third aspect of the present invention as described above, it is merely necessary to insert the second engaging projection piece 28 between the back surface of the upper portion of the cylinder 4, and the construction thereof can be thereby simple, and the attachment and detachment operations can be easily carried out.

The reference to any prior art in this specification is not, and should not be taken as, an acknowledgment or any form of suggestion that that prior art forms part of the common general knowledge in Australia.

Throughout this specification and the claims which follow, unless the context requires otherwise, the word "comprise", and variations such as "comprises" and "comprising", will be understood to imply the inclusion of a stated integer or step or group of integers or steps but not the exclusion of any other integer or step or group of integers or steps.

The reference numerals in the following claims do not in any way limit the scope of the respective claims.



What is claimed is:

1. A trigger-type liquid dispenser comprising

a mounting sleeve (2) to be fitted onto a neck portion of a container body,

a vertical sleeve (2a) erected from the mounting sleeve (2),
an ejecting sleeve (3) projected forwardly from an upper end portion of the vertical sleeve (2a),

a cylinder (4) projected forwardly from a middle portion of the vertical sleeve (2a),

a plunger (6) slidably engaged in the cylinder (4), said plunger (6) being urged forwardly,

a trigger (5) swingably attached to a front portion of the ejecting sleeve (3), a rear surface of an upper portion of the trigger (5) being engaged with an front end portion of the plunger (6),

a nozzle fitting sleeve (7) fitted to a front end portion of the ejecting sleeve (3), and

a nozzle head (8) rotatably fitted to an outer surface of the nozzle fitting sleeve (7), said nozzle head (8) being formed with a nozzle hole (10),

wherein liquid stored in the container body is sucked up and ejected through the nozzle hole (10) by pulling the trigger (5) rearwardly,

characterized in that

an arm (21) is projected rearwardly from an outer surface of the nozzle head (8),

a first engaging portion (23) is provided at an upper portion of the trigger (5),



a second engaging portion (26) is provided at a front surface of a lower portion of the cylinder (4), and

when the trigger (5) is positioned at its front-most position and the nozzle head (8) is rotated, a part of the arm (21) is detachably engaged with the first engaging portion (23), another part of the arm (21) is detachably engaged with the second engaging portion (26), so that the plunger (6) can not move rearwardly even if a user attempts to pull the trigger (5).

2. The trigger-type liquid dispenser according to the claim 1, wherein

a surrounding sleeve (29) is unrotatably engaged with an outer surface of the nozzle head (8), and

an arm (21) is rearwardly projected from the surrounding sleeve (29).

3. The trigger-type liquid dispenser according to the claim 1, wherein

an engaging plate (24) is formed on and projected from a side surface of an upper portion of the trigger (5),

the engaging plate (24) is formed with a through-hole which is bored perpendicularly and acts as the first engaging portion (23),

a first engaging projection piece (22) is formed and projected from a middle portion of the arm (21), and

the first engaging projection piece (22) is engagable with the through-hole of the engaging plate (24).

4. The trigger-type liquid dispenser according to the claim 1, wherein

the trigger-type liquid dispenser has a body cover (25)



- 14 -

which covers the vertical sleeve (2a), the ejecting sleeve (3) and the cylinder (4).

a front surface of the body cover (25) acts as the second engaging portion (26).

5. The trigger-type liquid dispenser according to the claim 1, wherein

5 a rear surface of an upper portion of the trigger (5) acts as the first engaging portion (23),

a front surface of a lower portion of the cylinder (4) acts as the second engaging portion (26),

10 a second engaging projection piece (28) is projected sideward and outward from a rear portion of the arm (21), and

the second engaging projection piece (28) is position or engaged between the first engaging portion (23) and the second engaging portion (26).

6. A trigger-type liquid dispenser substantially as hereinbefore described with
15 reference to Figures 1 to 11 of the accompanying drawings.

DATED this 20th day of June, 2001

Yoshino Kogyosho CO., Ltd

20 by DAVIES COLLISON CAVE
Patent Attorneys for the Applicant

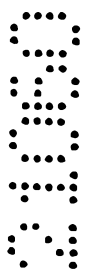
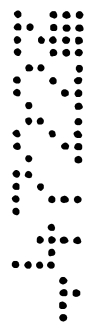

FIG 1

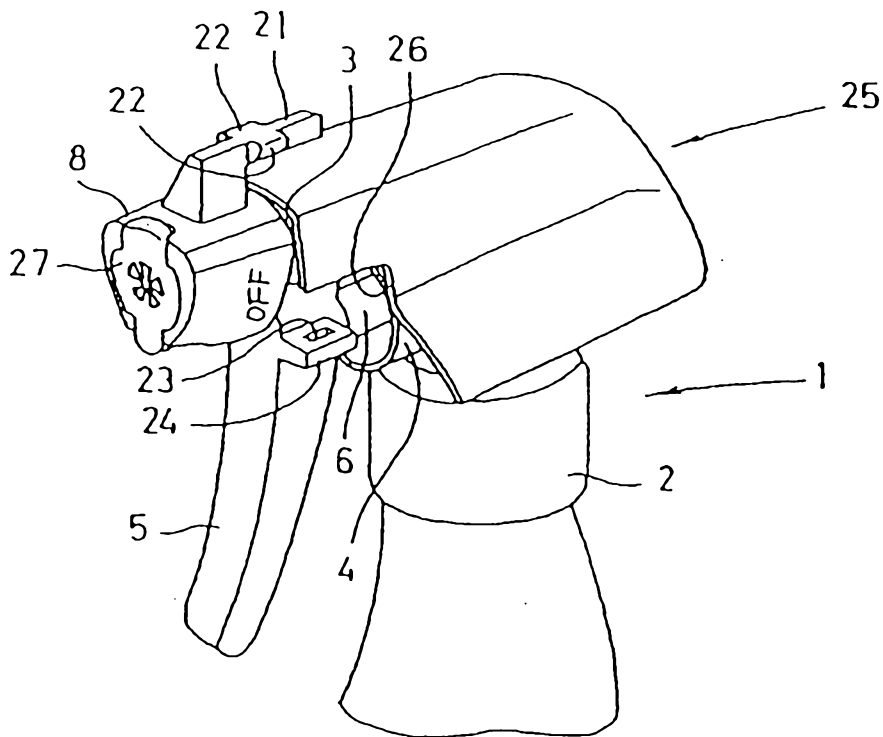

FIG 2

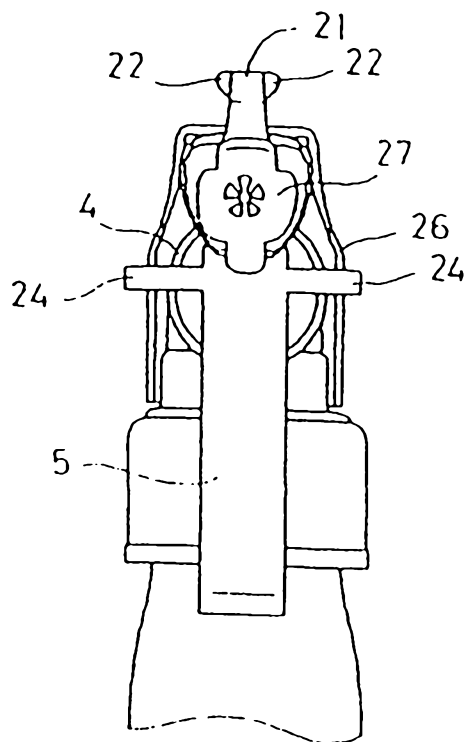

FIG 3

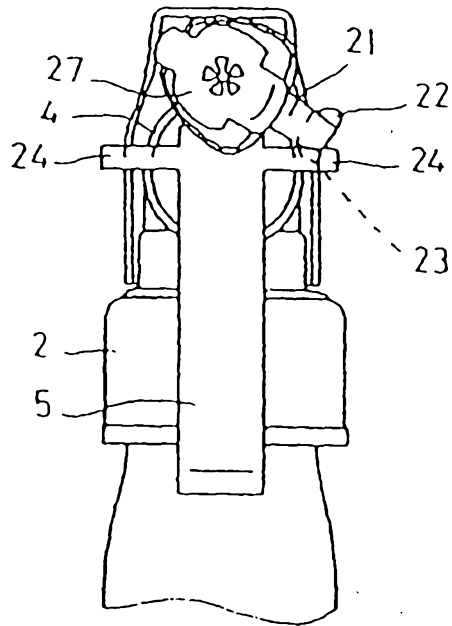

FIG 4

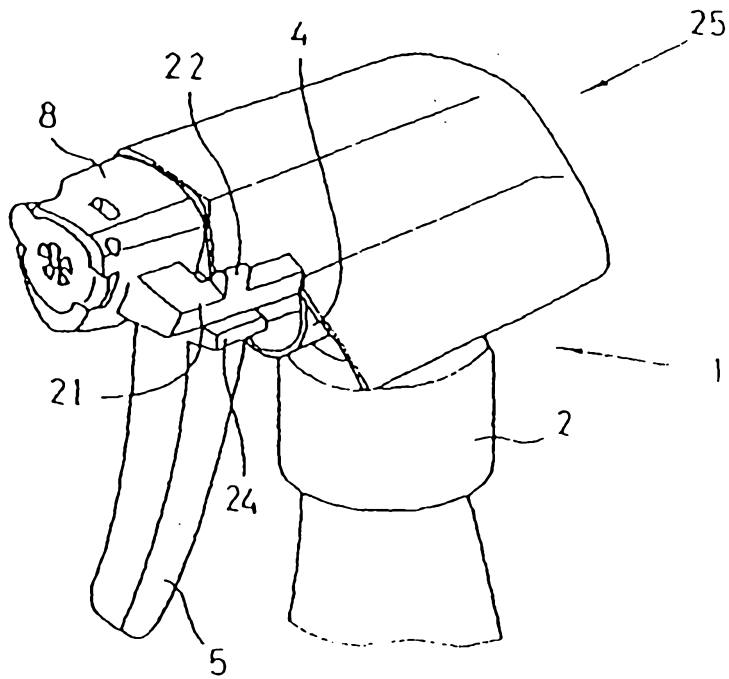

FIG 7

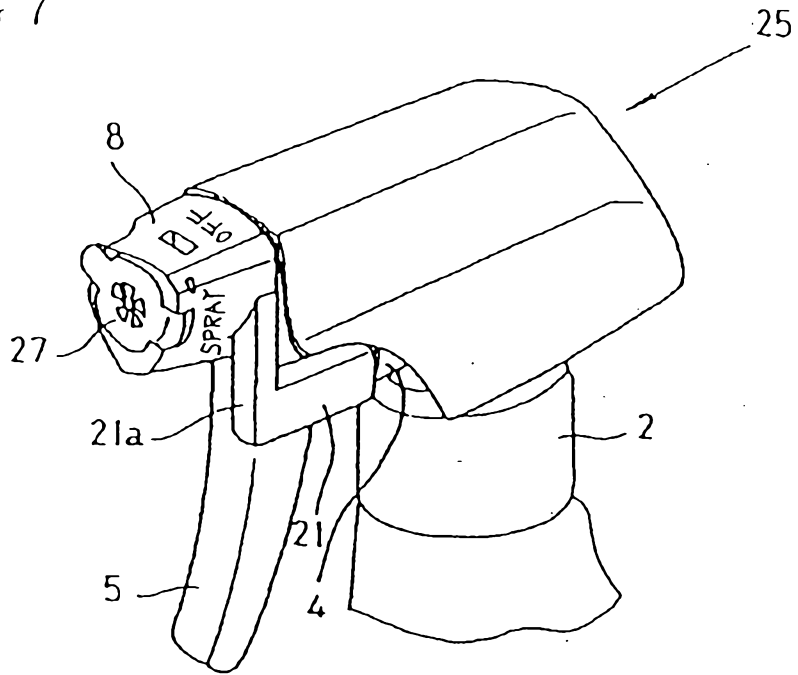

FIG 8

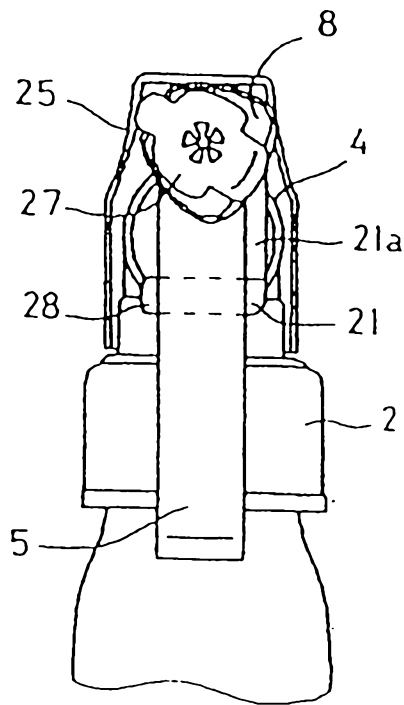

FIG 9

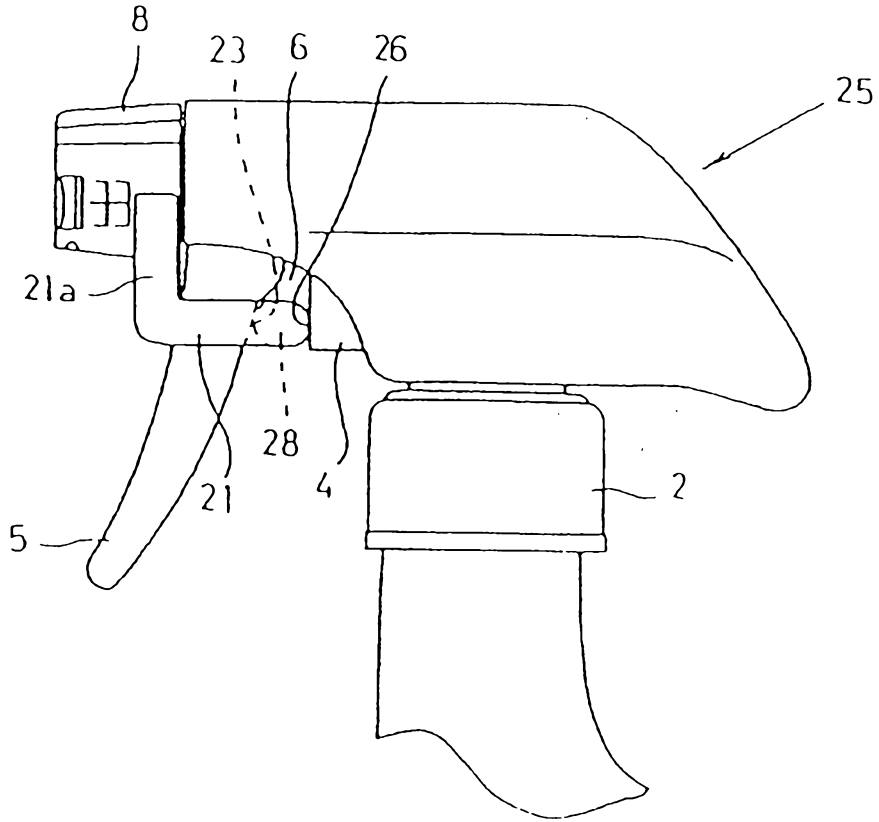

FIG 10

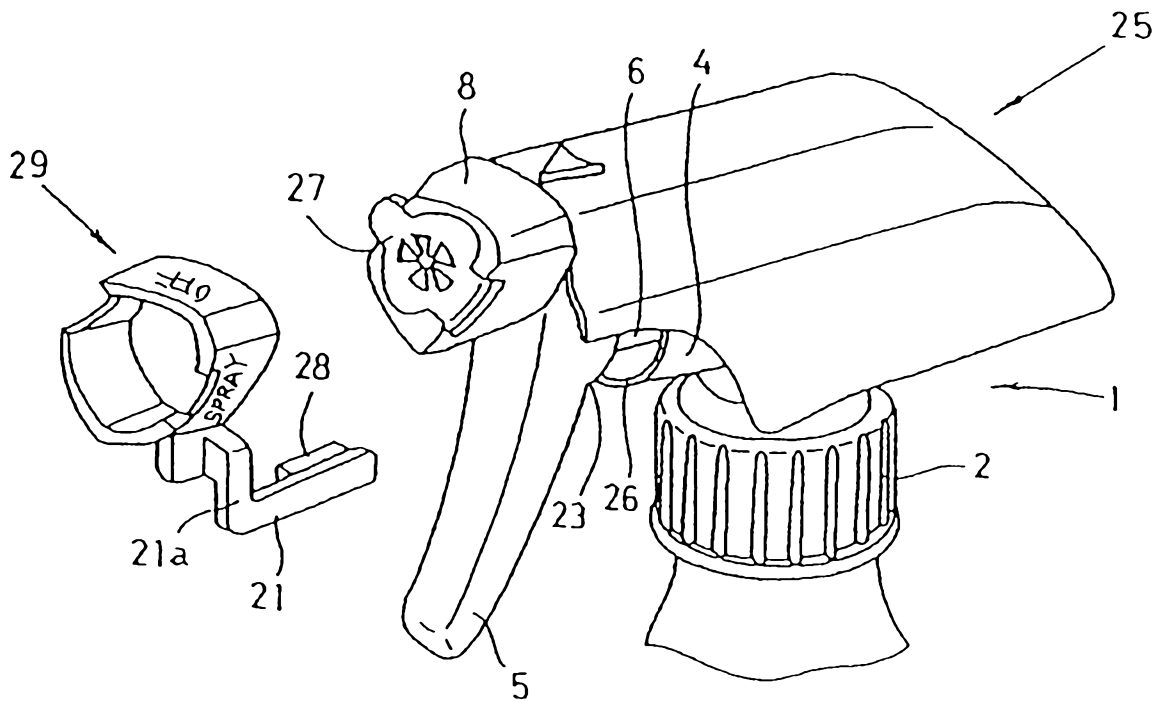

FIG 11

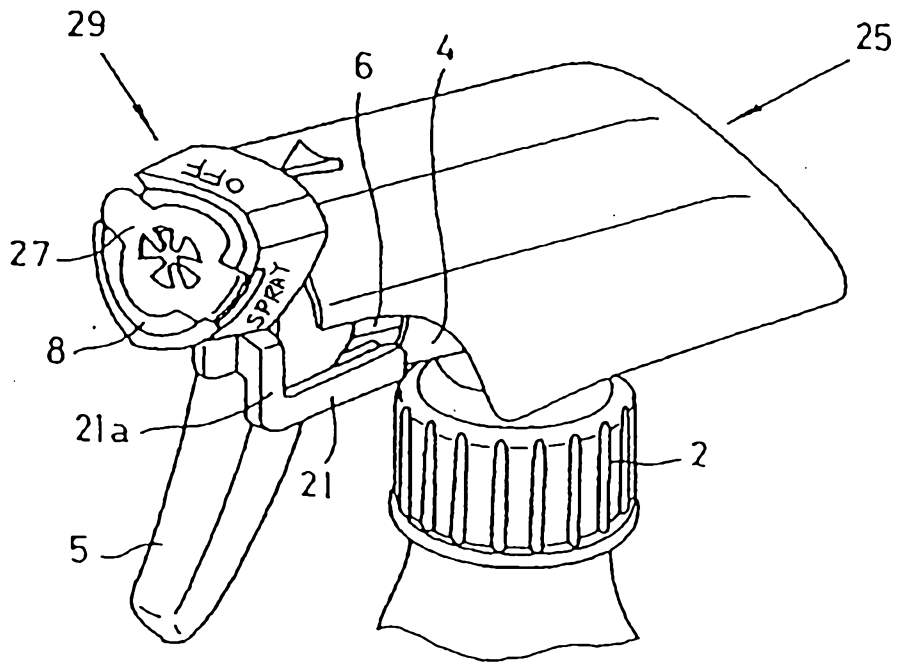

FIG 12

