



US 20080105772A2

(19) **United States**
(12) **Patent Application Publication**
MATLIN

(10) **Pub. No.: US 2008/0105772 A2**
(43) **Pub. Date: May 8, 2008**
REPUBLICATION

(54) **SHREDDER THROAT SAFETY SYSTEM**

Publication Classification

(75) Inventor: **Tai Hoon MATLIN**, Round Lake Beach,
IL (US)

(51) **Int. Cl.**
B02C 25/00 (2006.01)

Correspondence Address:
PILLSBURY WINTHROP SHAW PITTMAN,
LLP
P.O. BOX 10500
MCLEAN, VA 22102 (UNITED STATES)

(52) **U.S. Cl.** **241/37.5; 241/100**

(57) **ABSTRACT**

(73) Assignee: **FELLOWES INC.**, Itasca, IL (US)

(21) Appl. No.: **11/177,480**

(22) Filed: **Jul. 11, 2005**

Prior Publication Data

(65) US 2006/0054725 A1 Mar. 16, 2006

The present invention relates to a shredder that includes a housing having a movable part that forms at least a part of an opening for the insertion of articles to be fed into the shredder. A detector detects motion of the movable part, and in response, a controller performs a predetermined operation, including, for example, stopping cutting elements of the shredder mechanism.

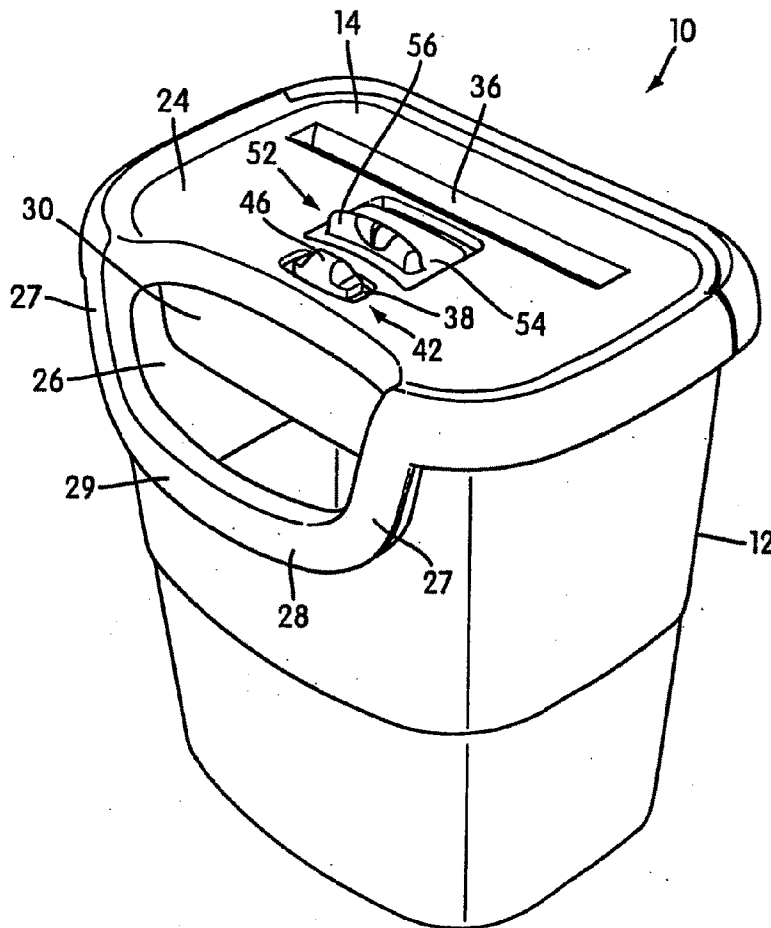

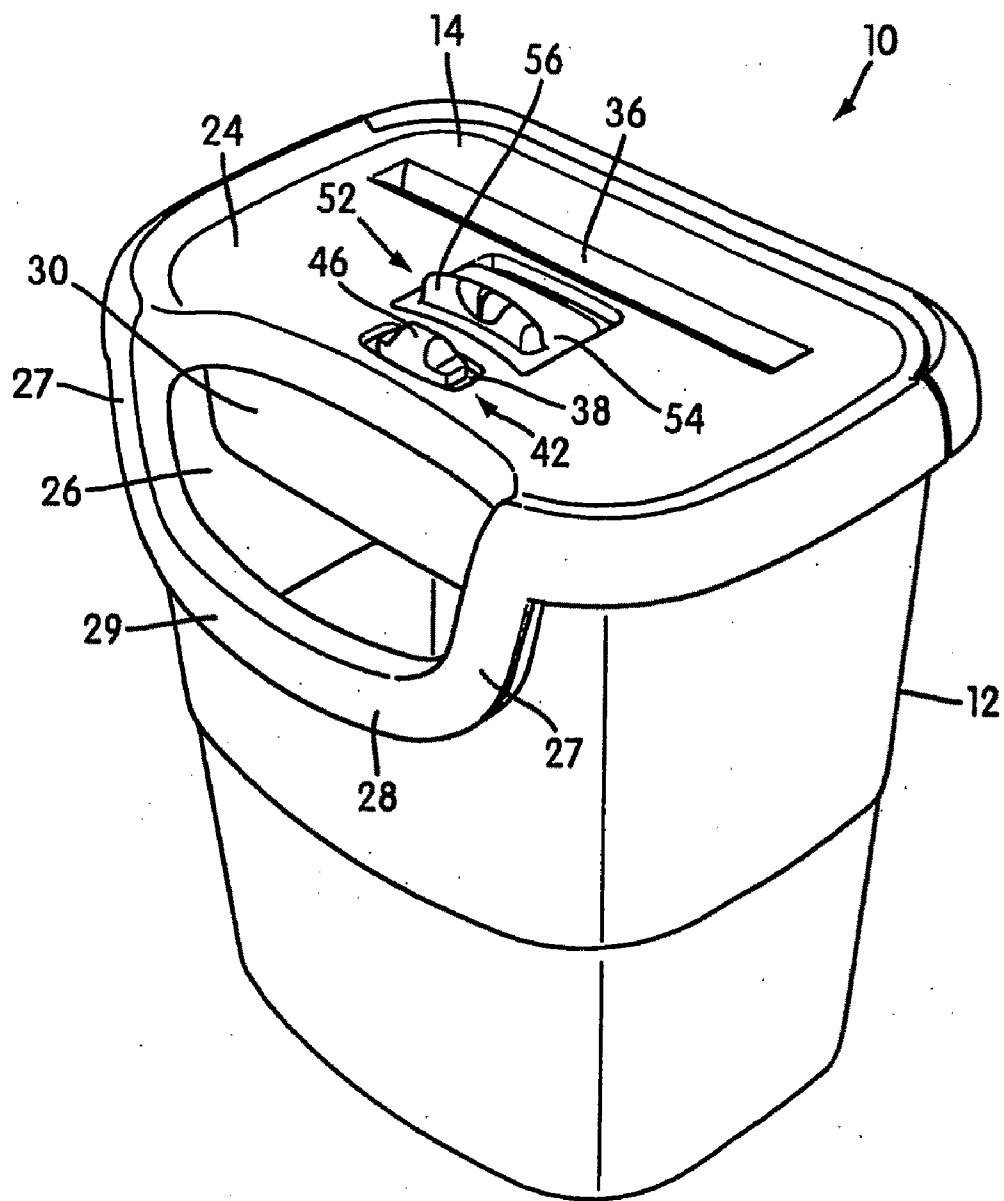

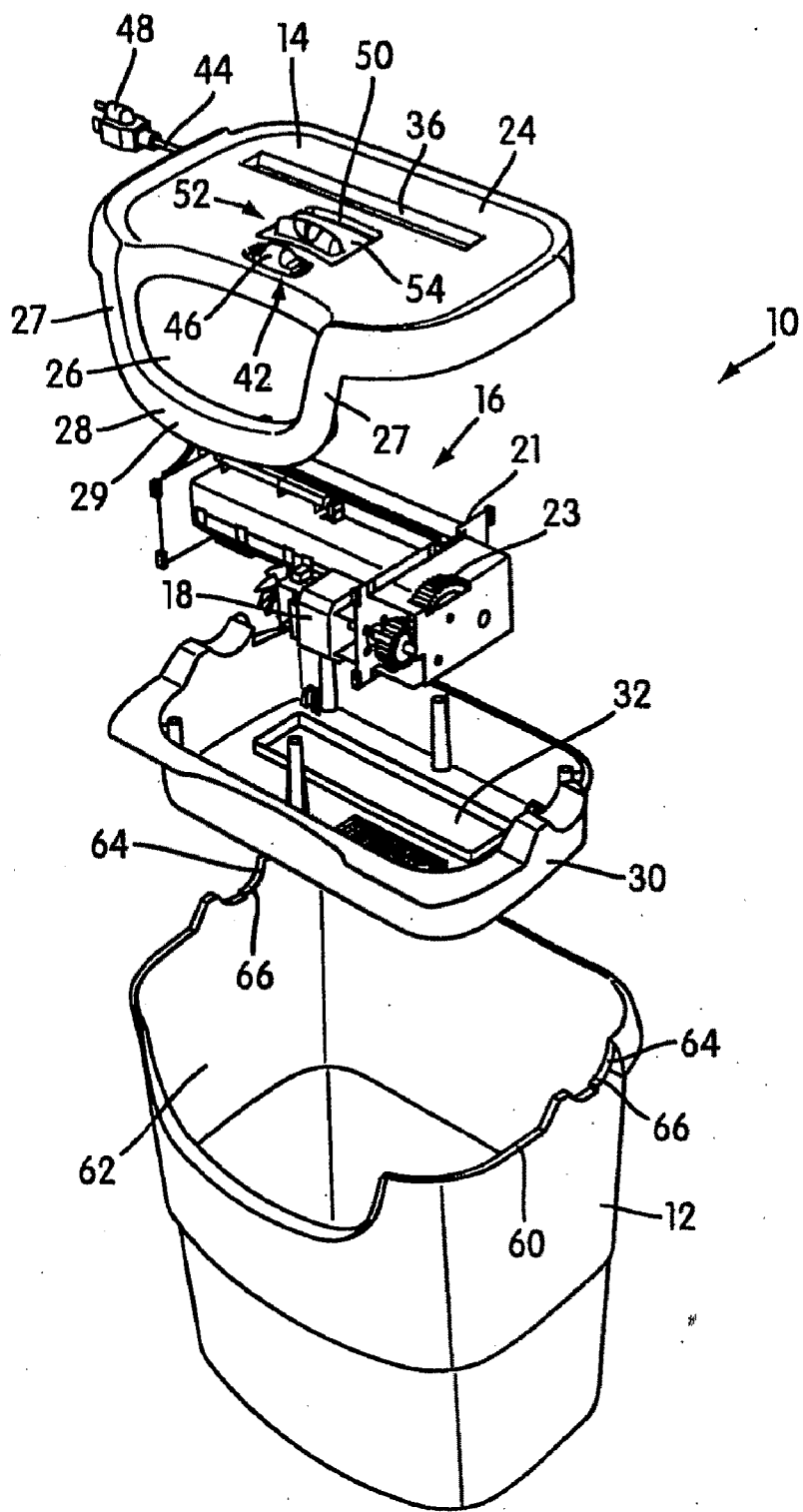

FIG. 2

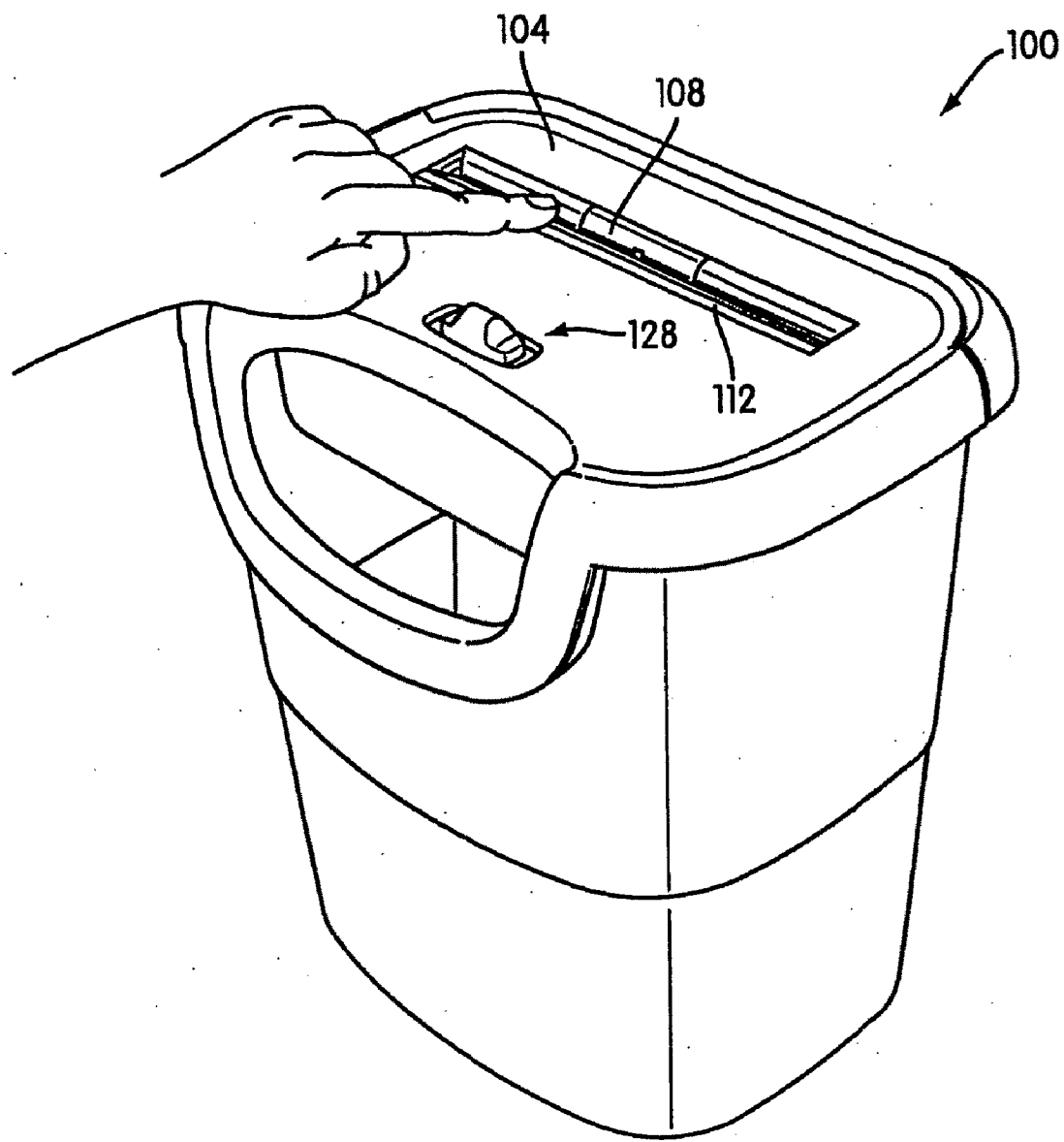

FIG. 3

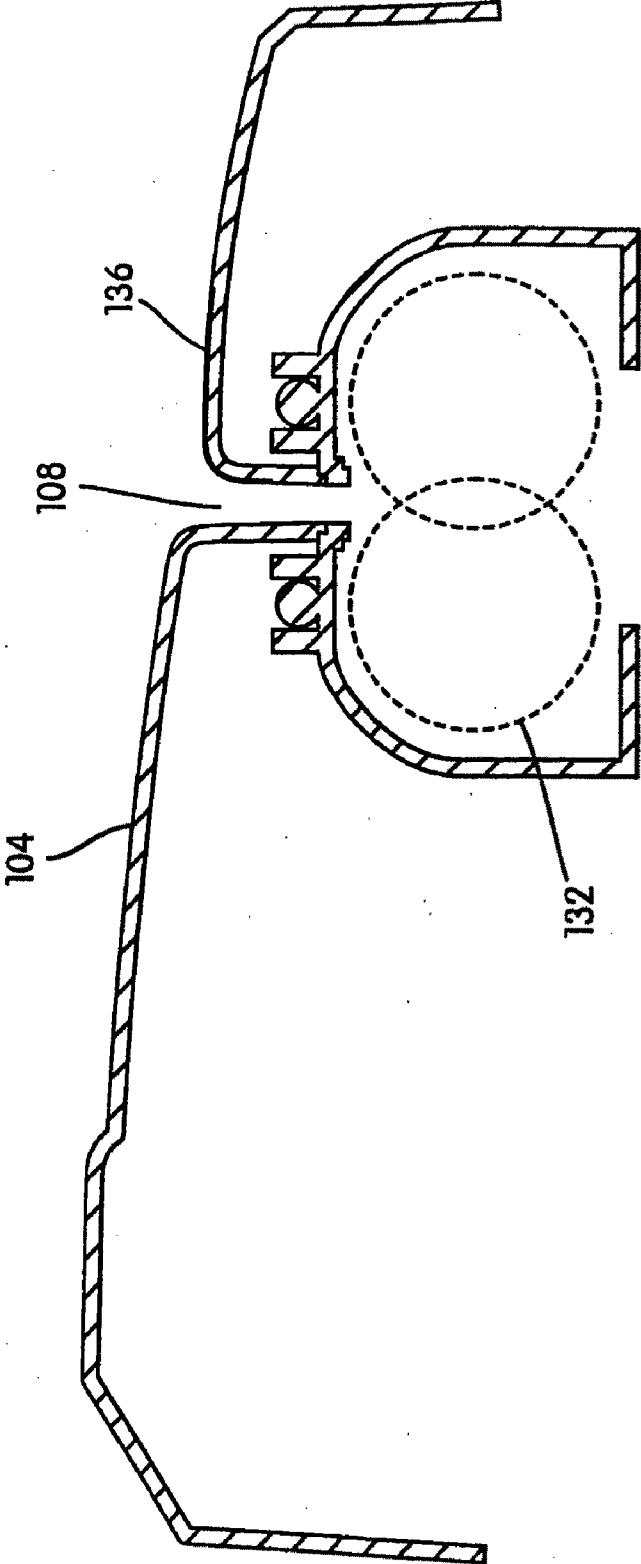

FIG. 4

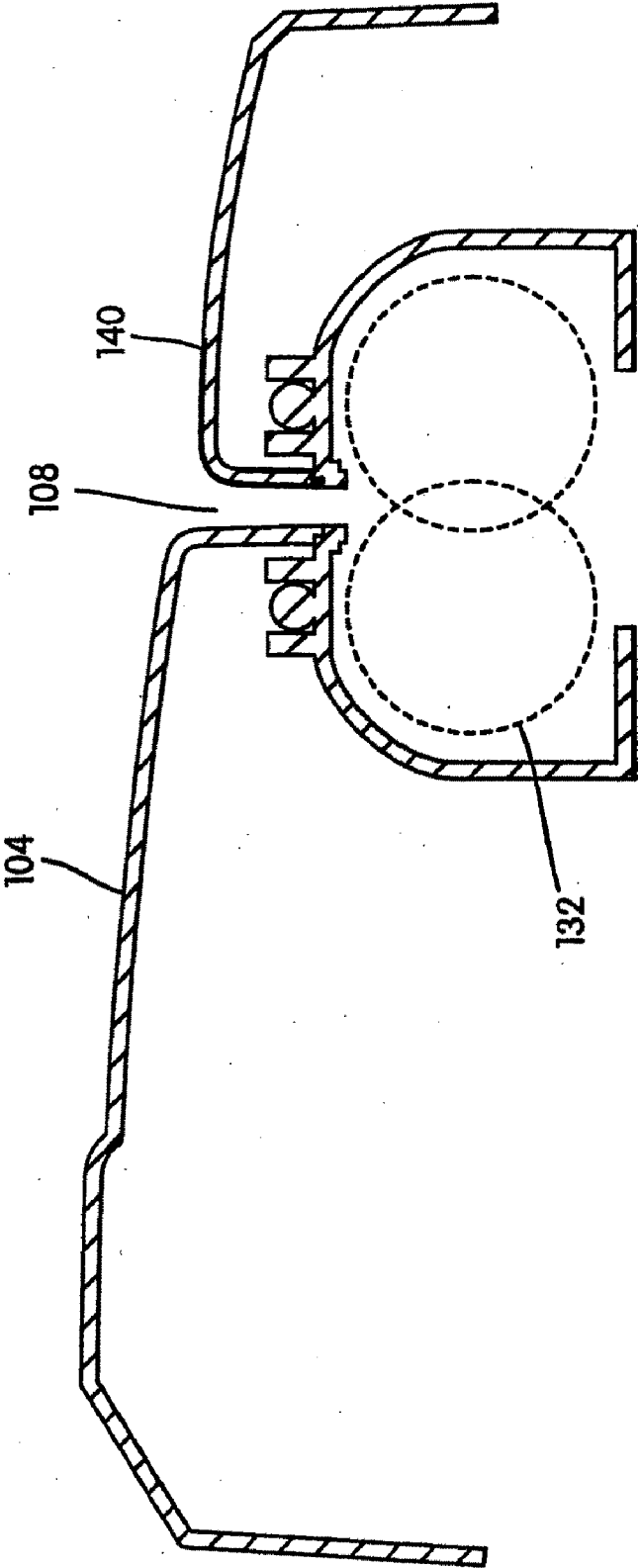

FIG. 5

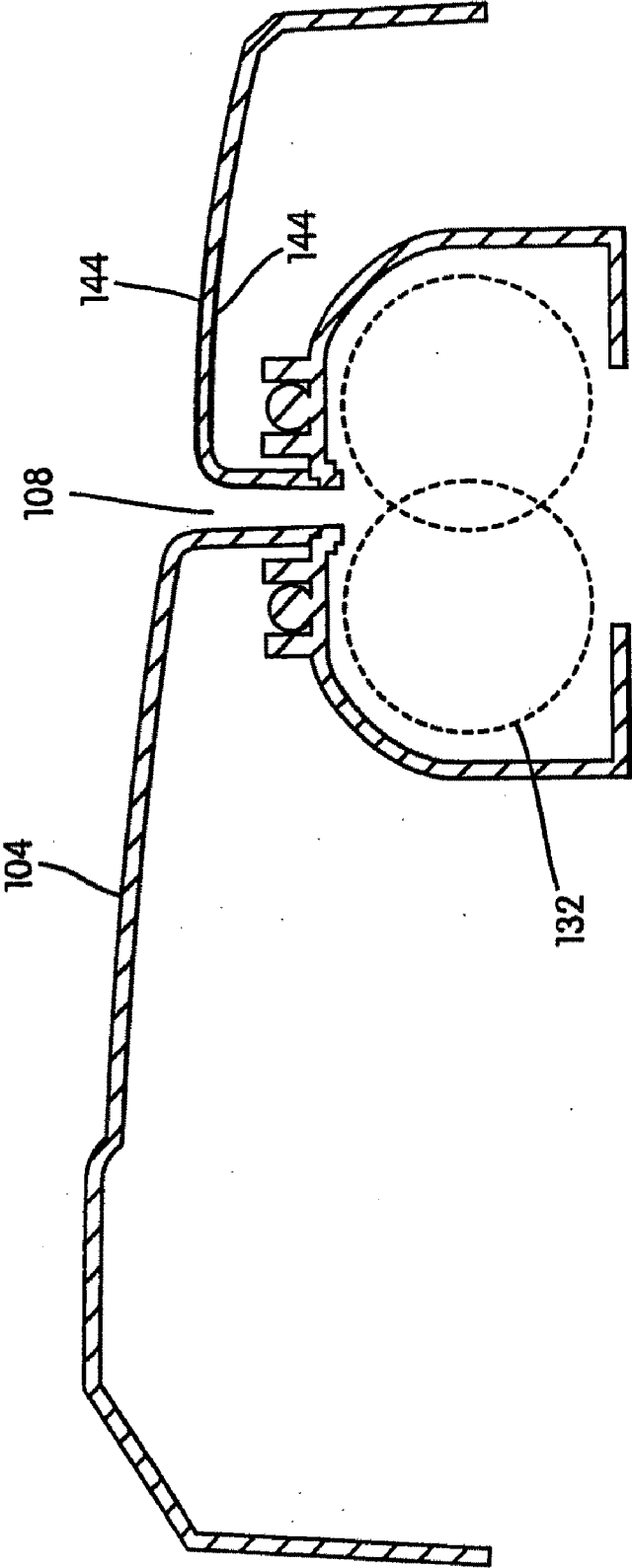

FIG. 6

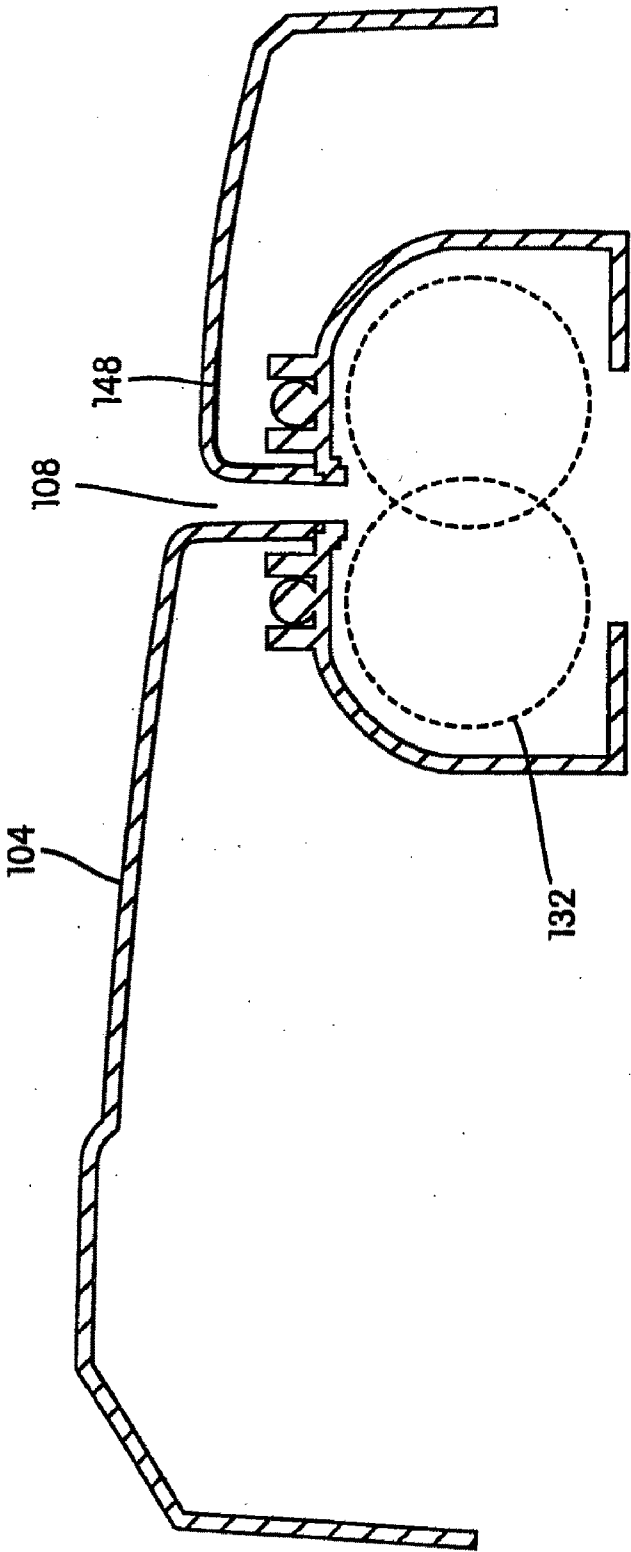

FIG. 7

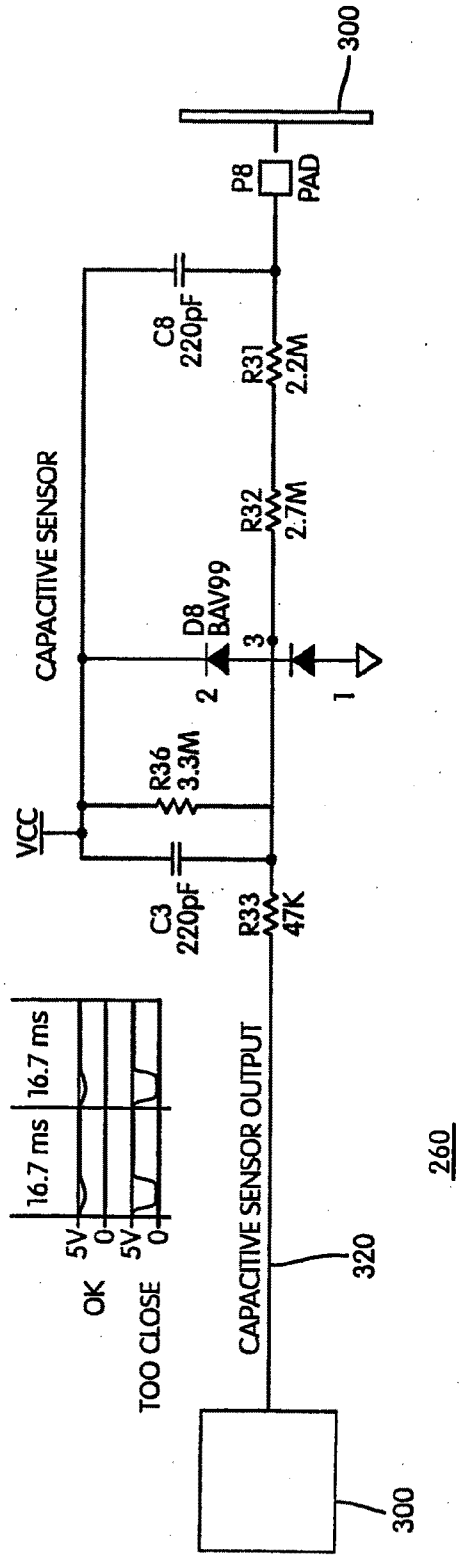

FIG. 8

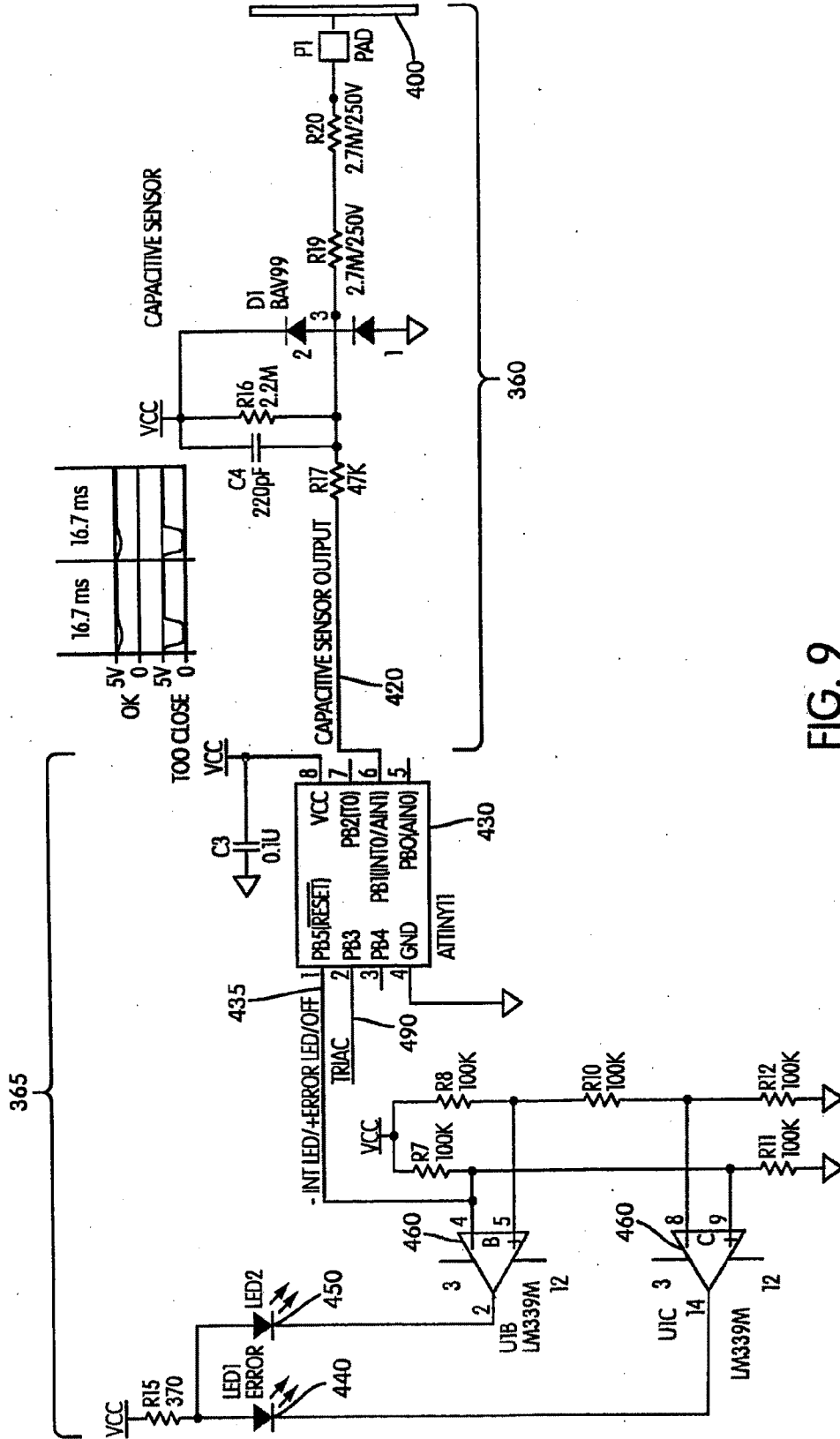

FIG. 9

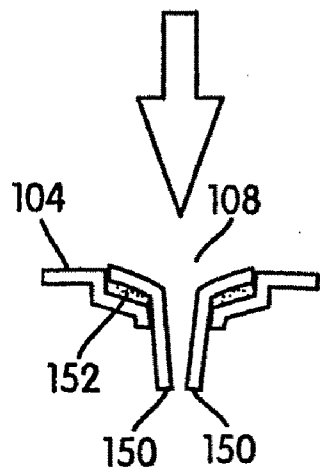

FIG. 10a

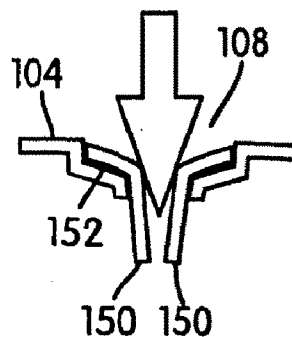

FIG. 10b

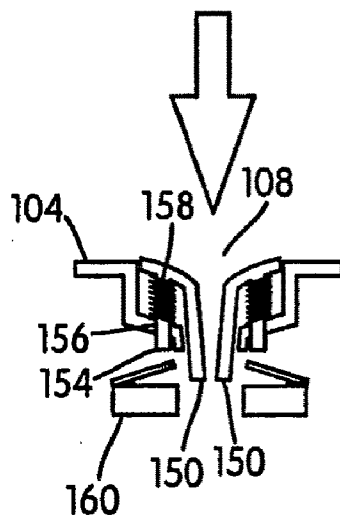

FIG. 11a

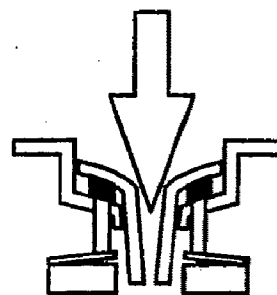

FIG. 11b

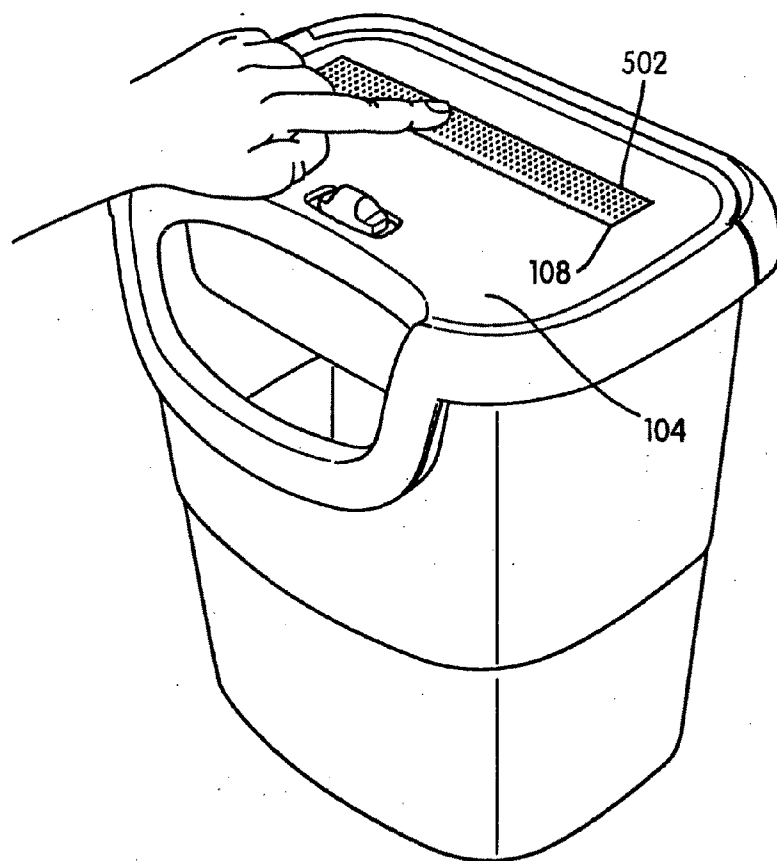

FIG. 12

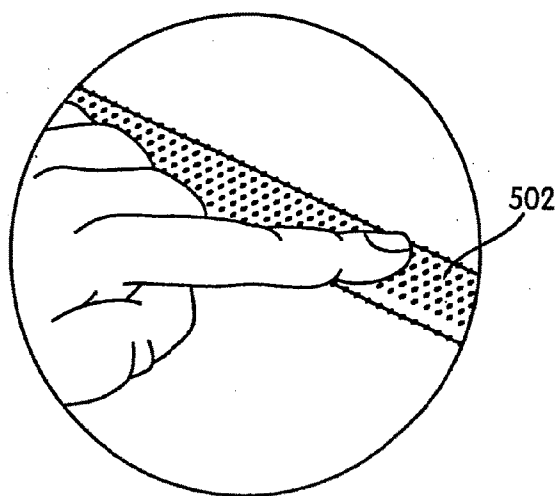

FIG. 12a

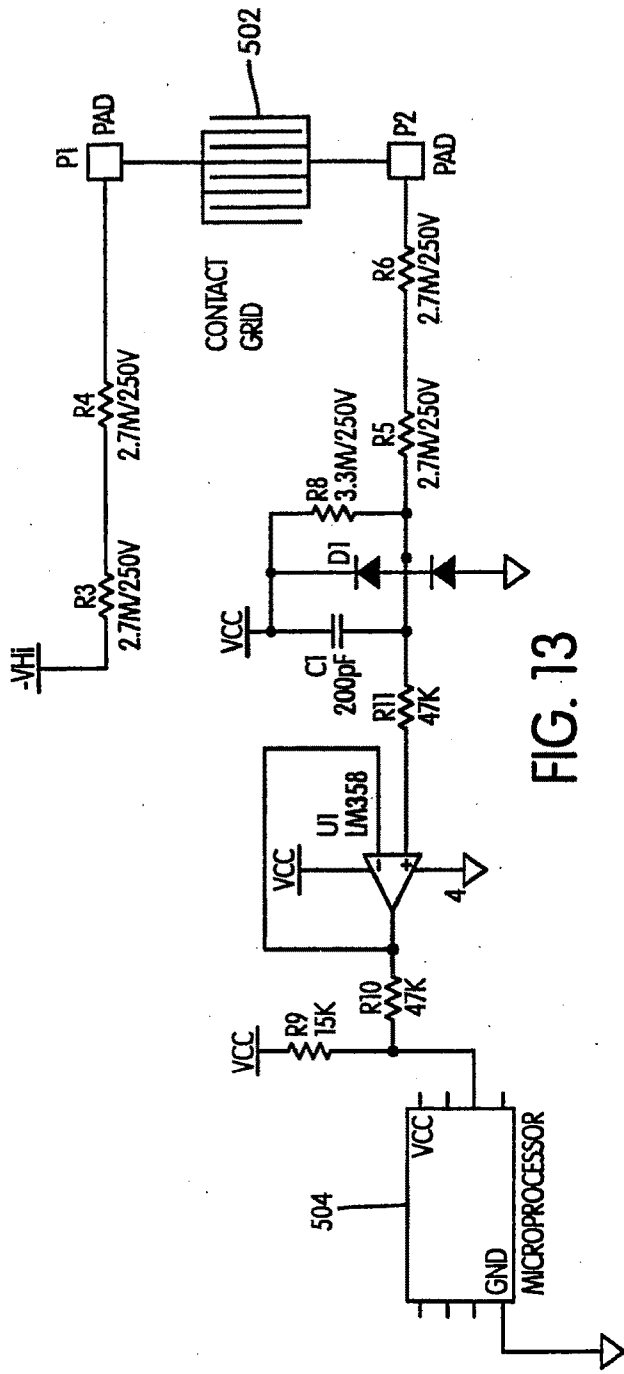

FIG. 13



FIG. 14

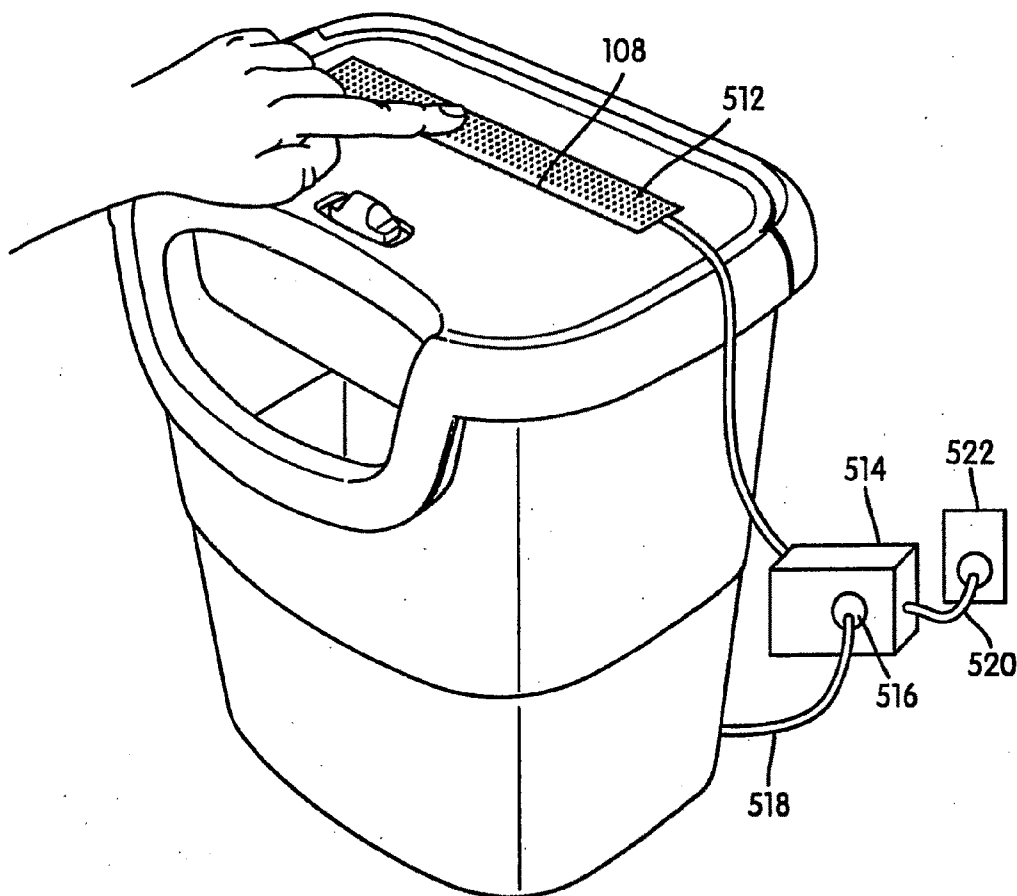

FIG. 15

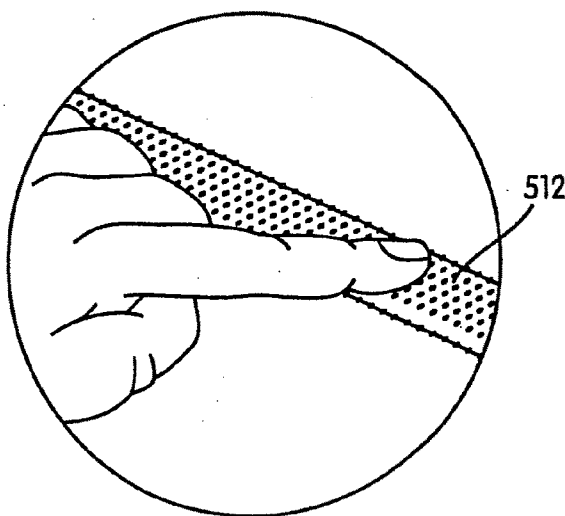

FIG. 15a

SHREDDER THROAT SAFETY SYSTEM

[0001] This application is a continuation-in-part of U.S. patent application Ser. No. 10/937,304, filed Sep. 1, 2004, and claims priority thereto, that application is incorporated herein by reference in its entirety.

FIELD OF THE INVENTION

[0002] The present invention relates to shredders for destroying articles, such as documents, CDs, etc.

BACKGROUND OF THE INVENTION

[0003] Shredders are well known devices for destroying articles, such as documents, CDs, floppy disks, etc. Typically, users purchase shredders to destroy sensitive articles, such as credit card statements with account information, documents containing company trade secrets, etc.

[0004] A common type of shredder has a shredder mechanism contained within a housing that is removably mounted atop a container. The shredder mechanism typically has a series of cutter elements that shred articles fed therein and discharge the shredded articles downwardly into the container. It is generally desirable to prevent a person's or animal's body part from contacting these cutter elements during the shredding operation.

[0005] The present invention endeavors to provide various improvements over known shredders.

SUMMARY OF THE INVENTION

[0006] One aspect of the present invention provides a shredder comprising a housing, a shredder mechanism including a motor and cutter elements, a proximity sensor, and a controller. The shredder mechanism enables articles to be shredded to be fed into the cutter elements, and the motor is operable to drive the cutter elements so that the cutter elements shred the articles fed therein.

[0007] The housing has an opening enabling articles to be fed therethrough into the cutter elements of the shredder mechanism for shredding. The proximity sensor is located adjacent the opening and configured to indicate the presence of a person or animal in proximity to the opening. The controller is operable to perform a predetermined operation (e.g., to disable the shredder mechanism) responsive to the indicated presence of the person or animal.

[0008] Another aspect of the invention provides a shredder with a proximity sensor that includes an electroconductive element and circuitry to sense a state of the electroconductive element. The proximity sensor is configured to indicate a change in the state of the electroconductive element corresponding to a change in capacitance caused by a person or animal approaching in proximity to the electroconductive element. A controller of the shredder is operable to perform a predetermined operation responsive to the indicated change in the state of the electroconductive element.

[0009] Another aspect of the invention provides a shredder having a housing, a shredder mechanism received in the housing and including an electrically powered motor and cutter elements, the shredder mechanism enabling articles to be shredded to be fed into the cutter elements and the motor being operable to drive the cutter elements so that the cutter elements shred the articles fed therein, the housing having a

movable part providing at least part of an opening enabling articles to be fed therethrough into the cutter elements of the shredder mechanism for shredding, the movable part being movable from a first position to a second position and being biased to the first position, a detector configured to detect movement of the movable part to the second position, the movable part being constructed to move from the first position to the second position upon a user attempting to force an article having a thickness greater than a predetermined thickness through the opening, and a controller operable to perform a predetermined operation responsive to the detector detecting that the movable part has moved to the second position.

[0010] Other objects, features, and advantages of the present invention will become apparent from the following detailed description, the accompanying drawings, and the appended claims.

BRIEF DESCRIPTION OF THE DRAWINGS

[0011] FIG. 1 is a perspective view of a shredder constructed in accordance with an embodiment of the present invention;

[0012] FIG. 2 is an exploded perspective view of the shredder of FIG. 1;

[0013] FIG. 3 is a perspective view of a shredder constructed in accordance with an embodiment of the present invention;

[0014] FIGS. 4-7 are cross-sectional views each showing a shredder housing, opening, cutting elements, and conductor configuration for a sensor in accordance with various embodiments of the present invention;

[0015] FIGS. 8 and 9 illustrate example capacitive sensor circuits according to respective embodiments of the present invention;

[0016] FIGS. 10a and 10b are cross-sectional views showing a shredder opening having a pressure-sensitive switch in accordance with embodiments of the present invention.

[0017] FIGS. 11a and 11b are cross-sectional views showing a shredder opening having an alternate pressure-sensitive switch in accordance with embodiments of the present invention;

[0018] FIGS. 12 and 12a are illustrations of a shredder constructed in accordance with an additional embodiment of the present invention;

[0019] FIG. 13 is a schematic diagram of an example of an electronic circuit for controlling the operation of a shredder in accordance with the embodiment of FIG. 12;

[0020] FIG. 14 is a schematic diagram of an electrical connection used in an embodiment of the present invention configured for retrofitting to an existing shredder; and

[0021] FIGS. 15 and 15a are illustrations of a retrofit embodiment of the present invention.

DETAILED DESCRIPTION OF THE ILLUSTRATED EMBODIMENTS

[0022] FIGS. 1 and 2 illustrate a shredder constructed in accordance with an embodiment of the present invention. The shredder is generally indicated at 10. The shredder 10 sits atop

a waste container, generally indicated at **12**, which is formed of molded plastic or any other material. The shredder **10** illustrated is designed specifically for use with the container **12**, as the shredder housing **14** sits on the upper periphery of the waste container **12** in a nested relation. However, the shredder **10** may also be designed so as to sit atop a wide variety of standard waste containers, and the shredder **10** would not be sold with the container. Likewise, the shredder **10** could be part of a large freestanding housing, and a waste container would be enclosed in the housing. An access door would provide for access to and removal of the container. Generally speaking, the shredder **10** may have any suitable construction or configuration and the illustrated embodiment is not intended to be limiting in any way.

[0023] The shredder **10** includes a shredder mechanism **16** including an electrically powered motor **18** and a plurality of cutter elements (not shown). "Shredder mechanism" is a generic structural term to denote a device that shreds articles using cutter elements. Such shredding may be done in any particular way. The cutter elements are generally mounted on a pair of parallel rotating shafts (not shown). The motor **18** operates using electrical power to rotatably drive the shafts and the cutter elements through a conventional transmission **23** so that the cutter elements shred articles fed therein. The shredder mechanism **16** may also include a sub-frame **21** for mounting the shafts, the motor **18**, and the transmission **23**. The operation and construction of such a shredder mechanism **16** are well known and need not be described herein in detail. Generally, any suitable shredder mechanism **16** known in the art or developed hereafter may be used.

[0024] The shredder **10** also includes the shredder housing **14**, mentioned above. The shredder housing **14** includes top wall **24** that sits atop the container **12**. The top wall **14** is molded from plastic and an opening **26** is located at a front portion thereof. The opening **26** is formed in part by a downwardly depending generally U-shaped member **28**. The U-shaped member **28** has a pair of spaced apart connector portions **27** on opposing sides thereof and a hand grip portion **28** extending between the connector portions **27** in spaced apart relation from the housing **14**. The opening **26** allows waste to be discarded into the container **12** without being passed through the shredder mechanism **16**, and the member **28** may act as a handle for carrying the shredder **10** separate from the container **12**. As an optional feature, this opening **26** may be provided with a lid, such as a pivoting lid, that opens and closes the opening **26**. However, this opening in general is optional and may be omitted entirely. Moreover, the shredder housing **14** and its top wall **24** may have any suitable construction or configuration.

[0025] The shredder housing **14** also includes a bottom receptacle **30** having a bottom wall, four side walls and an open top. The shredder mechanism **16** is received therein, and the receptacle **30** is affixed to the underside of the top wall **24** by fasteners. The receptacle **30** has an opening **32** in its bottom wall through which the shredder mechanism **16** discharges shredded articles into the container **12**.

[0026] The top wall **24** has a generally laterally extending opening **36** extending generally parallel and above the cutter elements. The opening **36**, often referred to as a throat, enables the articles being shredded to be fed into the cutter elements. As can be appreciated, the opening **36** is relatively narrow, which is desirable for preventing overly thick items,

such as large stacks of documents, from being fed into cutter elements, which could lead to jamming. The opening **36** may have any configuration.

[0027] The top wall **24** also has a switch recess **38** with an opening therethrough. An on/off switch **42** includes a switch module (not shown) mounted to the top wall **24** underneath the recess **38** by fasteners, and a manually engageable portion **46** that moves laterally within the recess **38**. The switch module has a movable element (not shown) that connects to the manually engageable portion **46** through the opening **40**. This enables movement of the manually engageable portion **46** to move the switch between its states.

[0028] In the illustrated embodiment, the switch module connects the motor **18** to the power supply (not shown). Typically, the power supply will be a standard power cord **44** with a plug **48** on its end that plugs into a standard AC outlet. The switch **42** is movable between an on position and an off position by moving the portion **46** laterally within the recess **38**. In the on position, contacts in the switch module are closed by movement of the manually engageable portion **46** and the movable element to enable a delivery of electrical power to the motor **18**. In the off position, contacts in the switch module are opened to disable the delivery of electric power to the motor **18**.

[0029] As an option, the switch **42** may also have a reverse position wherein contacts are closed to enable delivery of electrical power to operate the motor **18** in a reverse manner. This would be done by using a reversible motor and applying a current that is of a reverse polarity relative to the on position. The capability to operate the motor **18** in a reversing manner is desirable to move the cutter elements in a reversing direction for clearing jams. In the illustrated embodiment, in the off position the manually engageable portion **46** and the movable element would be located generally in the center of the recess **38**, and the on and reverse positions would be on opposing lateral sides of the off position.

[0030] Generally, the construction and operation of the switch **42** for controlling the motor **18** are well known and any construction for such a switch **42** may be used.

[0031] The top cover **24** also includes another recess **50** associated with a switch lock **52**. The switch lock **52** includes a manually engageable portion **54** that is movable by a user's hand and a locking portion (not shown). The manually engageable portion **54** is seated in the recess **50** and the locking portion is located beneath the top wall **24**. The locking portion is integrally formed as a plastic piece with the manually engageable portion **54** and extends beneath the top wall **24** via an opening formed in the recess **50**.

[0032] The switch lock **52** causes the switch **42** to move from either its on position or reverse position to its off position by a camming action as the switch lock **52** is moved from a releasing position to a locking position. In the releasing position, the locking portion is disengaged from the movable element of the switch **42**, thus enabling the switch **42** to be moved between its on, off, and reverse positions. In the locking position, the movable element of the switch **42** is restrained in its off position against movement to either its on or reverse position by the locking portion of the switch lock **52**.

[0033] Preferably, but not necessarily, the manually engageable portion **54** of the switch lock **52** has an upwardly

extending projection **56** for facilitating movement of the switch lock **52** between the locking and releasing positions.

[0034] One advantage of the switch lock **52** is that, by holding the switch **42** in the off position, to activate the shredder mechanism **16** the switch lock **52** must first be moved to its releasing position, and then the switch **42** is moved to its on or reverse position. This reduces the likelihood of the shredder mechanism **16** being activated unintentionally.

[0035] In the illustrated embodiment, the shredder housing **14** is designed specifically for use with the container **12** and it is intended to sell them together. The upper peripheral edge **60** of the container **12** defines an upwardly facing opening **62**, and provides a seat **61** on which the shredder **10** is removably mounted. The seat **61** includes a pair of pivot guides **64** provided on opposing lateral sides thereof. The pivot guides **64** include upwardly facing recesses **66** that are defined by walls extending laterally outwardly from the upper edge **60** of the container **12**. The walls defining the recesses **66** are molded integrally from plastic with the container **12**, but may be provided as separate structures and formed from any other material. At the bottom of each recess **66** is provided a step down or ledge providing a generally vertical engagement surface **68**. This step down or ledge is created by two sections of the recesses **66** being provided with different radii.

[0036] The shredder **10** has a proximity sensor to detect the presence of a person or thing (e.g., animal or inanimate object) in proximity to the opening **36**. A person or thing is "in proximity" to the opening **36** when a part thereof is outside and adjacent to the opening **36** or at least partially within the opening **36**. The proximity sensor may be implemented in various ways, such as is described in further detail below. For further examples of shredders on which a proximity sensor may be used, reference may be made to U.S. patent application Ser. Nos. 10/828,254 (filed Apr. 21, 2004), 10/815,761 (filed Apr. 2, 2004), and 10/347,700 (filed Jan. 22, 2003), each of which is hereby incorporated into the present application by reference. Generally, the proximity sensor may be used with any type of shredder, and the examples identified herein are not intended to be limiting.

[0037] FIG. 3 is a perspective view of a shredder **100** constructed in accordance with an embodiment of the present invention. The shredder **100** incorporates a capacitive sensor. The illustrated capacitive sensor is a switch that detects the presence of a person or thing without requiring physical contact. The capacitive sensor includes a conductor/contact plate **112** connected to a circuit, such as those shown in FIGS. 8 and 9. The conductor **112** serves as the first plate of a capacitor, while the person or thing to be detected serves as the second plate thereof. As the distance between the conductor **112** and the person or thing decreases, the mutual capacitance therebetween increases. This increase in capacitance results in increased signal levels in the sensor, which levels can be used to detect the proximity of the person or thing.

[0038] It is to be appreciated that capacitance depends in part on the dielectric constant of the second plate of a capacitor. A higher dielectric constant translates into a larger capacitance. Therefore, the capacitive sensor of the shredder **100** can detect the proximity of a nearby animate or inanimate entity provided that its respective dielectric constant is sufficiently high. Because human beings and various animals have relatively high dielectric constants, they are detectable by the

capacitive sensor. Inanimate objects with relatively high dielectric constants also are detectable. Conversely, objects with low or moderate dielectric constants, such as paper, are not detectable.

[0039] The shredder **100** includes a shredder housing **104**, an opening **108**, and a control switch **128** with on, off, and reverse positions. A shredder mechanism, such as the one described above, is located beneath the opening **108** so that documents can be fed into the shredder mechanism through the opening **108**.

[0040] The conductor **112** can be, for example, a strip of metal, foil tape (e.g., copper tape), conductive paint, a silk-screened conductive ink pattern, or another suitable conductive material. As shown in FIG. 3, the conductor **112** is a 9-inch by 1-inch capacitive sensing strip that is affixed to the housing **104** near the opening **108**. As such, when a person or thing nears the opening **108** and thus the cutter elements of the shredding mechanism of the shredder **100**, the capacitance between the conductor **112** and the person or thing increases, resulting in an increase in the signal level used for detection, as will be described below. To ensure that the switch is sensitive enough to detect the person or thing through multiple sheets of paper, the conductor **112** extends into the opening **108** to increase the overall surface area of the conductor **112** and thus the amount of capacitance between the conductor **112** and the nearby person or thing. The conductor **112** optionally can be covered by non-conductive plastic, for example, thus concealing the switch from a user of the shredder **100**. In addition, to increase sensitivity of the switch, such non-conductive plastic can be covered with a conductive material, such as metal foil.

[0041] Though not illustrated in FIG. 3, the shredder **100** can include a sensor light, an error light, and/or a light indicative of normal operation. The sensor light, which can be an LED, is illuminated when a person or thing is detected. The error light, which also can be an LED, is illuminated when a person or thing is detected, and optionally under other conditions (e.g., the shredder container is not properly engaged with the shredder **100**, or the shredder mechanism has become jammed). These lights, however, are not necessary, and are only optional features.

[0042] FIGS. 4-7 are cross-sectional views each showing a shredder housing **104**, opening **108**, cutting elements **132**, and a conductor configuration for a sensor in accordance with various embodiments of the present invention. The conductor configurations can include conductor(s) of different areas to tailor the amount of capacitance and thus the signal level produced when a person or thing nears the shredder. Where multiple conductors are employed, the distance therebetween may be designed also to tailor the amount of capacitive coupling and thus the capacitance produced.

[0043] In FIG. 4, the conductor **136** comprises a conductive material embedded within the upper wall of the housing **104** beneath the upper surface partially into the opening **108**. The conductor **136** also is optionally embedded in the wall defining the opening **108** and extends along it for a portion.

[0044] In FIG. 5, the conductive material of the conductor **140** covers an upper surface portion of the housing **104**, extends substantially into the opening **108**, and curves around a Range of the housing **104** so as to cover an inside surface portion of the housing **104**. For a conductor **140** that has a

noticeable amount of thickness, the top portion of the upper surface where the conductor **140** is mounted may be recessed.

[0045] The conductor **144** of FIG. 6 includes two conductive portions respectively affixed to outside and inside surface portions of the housing **104**. Such use of multiple portions increases the surface area of the capacitor, as well as the capacitive coupling, capacitance, and signal level produced when a person or thing nears the conductive portions.

[0046] The conductor **148** of FIG. 7 comprises a conductive material on an inside surface portion of the housing **104**. This is desirable for concealing the conductor **148** without adding the manufacturing step of embedding the conductor in a housing wall, such as is shown in FIG. 4. It is to be appreciated that the conductors of FIGS. 4-7 may be of any suitable configuration, and the examples illustrated are in no way intended to be limiting.

[0047] A conductor or conductive material such as described above in connection with FIGS. 3-7 is typically connected to circuitry on a circuit board. FIGS. 8 and 9 illustrate example capacitive sensor circuits according to respective embodiments of the present invention. The example circuits may be incorporated into the overall circuit design of a shredder, and are in no way intended to be limiting.

[0048] In FIG. 8, the capacitive sensor circuit **260** includes a conductor **300** that can have a configuration such as shown above or another suitable configuration. The conductor **300** is connected to a pad **P8**, which is in turn connected to circuit loops including capacitors **C8** and **C9**, resistors **R31**, **R32**, and **R36**, and a high-speed double diode **D8**. The loops are connected to a voltage supply **Vcc**, circuit ground, and a resistor **R33**. The voltage supply **Vcc** is connected to the AC line voltage of the shredder, and a negative regulator can generate -5 volts for the circuit ground. The capacitive sensor output **320** may be in turn coupled as an input to a controller **330**, such as a microprocessor or discrete circuit components (e.g., comparators, transistors), which takes appropriate action in response to signal levels at the output **320**. Such a controller **330** may also be a relay switch that opens to disable the delivery of power to an element (e.g., the motor of the shredder mechanism) and closes to enable the delivery of power. It is to be appreciated that "controller" is a generic structural term that denotes structure(s) that control one or more modules, devices, and/or circuit components.

[0049] The principles of operation of the circuit **260** will be readily understood by those conversant with the art. When a person or thing moves close to the conductor **300**, the increased capacitance therebetween causes the amplitude of the sinusoidal waveform at the output **320** to increase by a voltage sufficient to indicate the presence of the person or thing. Based on the increased signal level, the controller **330** can, for example, disable the cutting elements of the shredder, illuminate a sensor or error light, and/or activate an audible alert.

[0050] FIG. 9 illustrates a capacitive sensor circuit **360**, as well as control and illumination circuitry **365**. The capacitive sensor circuit **360** includes a conductor **400** that can have a configuration such as shown above or another suitable configuration. The conductor **400** is connected to a pad **P1**, which is in turn connected to series resistors **R19** and **R20**. The resistor **R19** is connected to circuit loops including a capaci-

tor **C4**, a resistor **R16**, and a high-speed double diode **D1**. The loops are connected to a voltage supply **Vcc**, circuit ground, and a resistor **R17**. The voltage supply **Vcc** is connected to the AC line voltage of the shredder, and a negative regulator can generate -5 volts for the circuit ground. The capacitive sensor output **420** is coupled as an input to a controller **430**, which can be, for example, a simple analog circuit or an ATtiny11 8-bit microcontroller offered by Atmel Corporation (San Jose, Calif.).

[0051] The principles of operation of the circuitry of FIG. 9 will be readily understood by those conversant with the art. When a person or thing moves close to the conductor **400**, the increased capacitance therebetween causes the amplitude of the sinusoidal waveform at the output **420** to increase by a voltage sufficient to indicate the presence of the person or thing. Based on the increased signal level, the controller **430** sends appropriate control signals. For example, the controller **430** sends a control signal **490** to cut off power (such as supplied by a triac) to the motor that drives the cutting elements of the shredder, and a control signal **435** to illuminate a sensor LED **450** or error LED **440** coupled to comparators **460**.

[0052] Embodiments of the present invention may be incorporated, for instance, in a shredder such as the PS80C-2 shredder of Fellowes, Inc. (Itasca, Ill.). If desired, existing shredder designs may be adapted, without major modification of existing modules, to incorporate proximity sensing circuitry.

[0053] In another embodiment of the invention, a shredder can provide two or more sensitivity settings for proximity sensing. The settings can be selectively enabled by a user and tailored to detect, e.g., infants or pets. In an example embodiment employing a capacitive sensor, objects are distinguished based on load times. A smaller capacitive load results in a shorter load time than a large capacitance. Thus, by measuring (e.g., with a microprocessor) differences in load times resulting from capacitive loads near a sensor, various objects can be distinguished.

[0054] In yet another embodiment of the invention, a mechanical switch or another type of detector is used to detect insertion of a foreign object. When the mechanical switch is actuated, the shredder blades are shut off, stopping the shredding operation (or some other operation is performed). In general, objects that are appropriate for shredding are thin and flat, e.g., paper, CDs, disks, credit cards and the like. Human and animal body parts, on the other hand are generally thicker. As a result, insertion of a body part into a shredder opening will result in pressure against the sides of the opening. For an opening having angled sides, this pressure will include both a component in the direction in which articles are fed through the opening (typically vertical) and a component perpendicular to the feed direction (typically horizontal). By allowing for some relative movement of the throat plate, this pressure may be used to actuate the mechanical switch. By appropriate selection of the size of the opening and the throw distance of the switch (or, when another type of detector such as an optical switch or a strain gauge is used, the sensitivity or active detection region), the shredder can be designed not to allow any object greater than a predetermined size (e.g., the size of a human finger, the size of a stack of paper too large for the shredder to handle) to enter the shredder throat without actuating the switch. This arrangement can also be used to

prevent a user from inserting overly thick stacks of documents or other articles that could jam the shredder mechanism.

[0055] FIGS. 10*a* and 10*b*, illustrate a first embodiment of a mechanical switch for use in a shredder. As shown in FIG. 10*a*, the shredder housing 104 includes an opening 108. The walls 150 of the opening 108 are moveable parts that form a throat plate that is moveable relative to the shredder housing 104. Each of these walls 150 has an upper portion mounted against a pressure sensitive switch 152 which may be, for example, a foil switch. The mechanical switch may have, for example, an open state and a closed state, which may otherwise be considered as an on position or an off position.

[0056] In a particular embodiment, the foil switch includes an upward biasing member (not separately illustrated) that tends to maintain the switch in an open position, as well as to bias the walls 150 of the opening 108 in their upper position. As illustrated each wall 150 is independently moveable and each has an associated switch 152, however as will be appreciated, the symmetrical arrangement is not required and either one or both of the walls may have an associated switch or detector. Likewise, the walls need not be independently moveable and may move together.

[0057] While FIG. 10*a* illustrates the open position of the switch, FIG. 10*b* illustrates what happens when a relatively large object is inserted into the opening 108. As an object (schematically illustrated by the arrow) is inserted into the opening 108, it presses against the walls 150, and moves them downwardly, compressing the foil switch 152. This action completes a circuit that shuts off the cutting blades. Such a system has the further potential to reduce damage to the shredder caused by oversize objects becoming partially lodged in the opening, placing a strain on the cutter motors.

[0058] FIG. 11*a* illustrates another alternate embodiment of the invention. In this embodiment, the walls 150 of the opening include plunger portions 154. The plunger portions 154 extend through apertures 156 in the shredder housing 104. The plunger portions 154 are biased upward by a corresponding spring 158, maintaining the walls 150 in their upper position.

[0059] When a large object is inserted into the opening 108 as illustrated in FIG. 11*b*, the walls 150 are pressed downward and the plunger portions 154 come into contact with a mechanical switch 160. In the illustration, the switch 160 is a lever-type switch, however as will be apparent to one of ordinary skill in the art, a foil switch or other mechanical switch could be substituted. Likewise, a strain gauge to measure deflection of a structure could be used or an optical sensor for detecting the position of the walls 150 or other structure could be used. Generally, any suitable type of detector may be used.

[0060] The embodiments of FIGS. 10*a*, 10*b*, 11*a* and 11*b* each rely generally on downward pressure of the throat plate to actuate the switch that ends the shredding operation. As noted above, the pressure of a large object inserted into the angled walls of the opening will tend to have a horizontal component as well. Thus, a pressure plate that is sensitive to outward movement of the walls of the throat plate would also be suitable for use in embodiments of the present invention. Likewise, though the embodiments of FIGS. 10*a*, 10*b*, 11*a* and 11*b* are described in terms of automatically stopping the cutting blades, in one alternate configuration, activating the

switch could cause a warning indicator such as a light or sound to be activated. Any such predetermined safety operation could be used.

[0061] As another alternative, the lower portion of one or both the walls 150 could be resiliently deflectable. This could be done by, for example, by pivotally connecting a relatively rigid member so that it pushes against a spring or by making the lever portion from a resiliently deflectable material. A detector, such as a mechanical switch or any other suitable detector could be used to determine when the respective wall 150 has flexed outwardly to a certain extent. This would indicate that an article of greater than a predetermined thickness has been inserted into the opening. Then, a predetermined operation (e.g., shutting off the shredding mechanism, emitting a warning signal) can be performed.

[0062] FIG. 12 illustrates an additional embodiment of a switch in accordance with the present invention, and FIG. 12*a* is a magnified view isolating the switch portion. The structure of the embodiment of FIG. 12 is similar to that of the embodiment of FIG. 3. A switch 502 is affixed to the housing 104 near to the opening 108. The switch is configured to sense contact by a change in resistance, for example as a result of contact with the switch by a person's hand.

[0063] In one example, the switch includes a conductive grid, separated into two mutually adjacent conductors, this embodiment is represented schematically in FIG. 13 along with a control circuit. In a particular implementation, V_{Hi} is set to be nominally 20V less than V_{cc}. Pads P1 and P2 provide connectivity to the remainder of the circuit. The resistors R3-R6 are selected to have a large resistance, thereby limiting the current flowing through the circuit when activated. When a user's hand comes into contact with the grid, the circuit is completed and a current flows. The amplifier U1A (which may be, by way of example, an LM358, available from National Semiconductor), buffers the analog voltage produced, and passes it to an analog input of the microprocessor 504. The resistors R8, R9, R10 can be varied in order to change a sensitivity of the system, as desired.

[0064] The microprocessor can be selected to control the shredder in response to the signal from the amplifier U1A. In particular, the microprocessor can be set to control, for example, a triac that in turn controls the power to the shredder motor so that the blades stop when the switch 502 is contacted. Further, as noted above, a warning light or LED may be activated to inform the user why the motor has been deactivated.

[0065] Because the total resistance of the switch grid 502 can change, for example due to build up of dirt, the signal level can vary. Likewise, a user with moist fingers will provide less resistance than one with dry fingers, etc. Therefore, in one embodiment, the shredder's control software can include routines for monitoring nominal resistance over time, and adjust a threshold accordingly. Similarly, one embodiment of the present invention allows for monitoring a change in the signal rather than a strength of the signal, thereby discriminating between a slow build-up of dirt and a transitory contact. Finally, in one embodiment, as the measured nominal resistance falls below a predetermined level, an indicator, e.g., an LED, can be used to inform the user that the grid should be cleaned.

[0066] In another alternate embodiment, the switch may be a retrofit device. As shown schematically in FIG. 14, the

retrofit device is interposed between the shredder and the power supply. The shredder is plugged into a controller rather than directly into a wall power supply. During normal operation, the retrofit device acts as a pass-through for power from the wall outlet to the shredder, and the shredder will operate substantially as it does when normally plugged into the wall. However, when the switch is activated, a controller, which may be, for example, similar to the one illustrated in FIG. 13, can cut off power to the shredder and/or provide an indication of a fault condition.

[0067] As illustrated in FIGS. 15 and 15a, the retrofit switch 512 itself may be a resistance sensitive switch, a capacitance sensitive switch or a pressure sensitive switch such as a membrane or foil switch, for example. The switch is affixed, permanently or removably, by use of an adhesive or a fastener to a position proximate the opening 108. It is electrically connected to a controller 514 which may be entirely separate, or may simply be a small package that can be affixed to the shredder housing. As noted above, the controller includes a receptacle 516 for the power cord 518 of the shredder, and will generally include its own power cord 520 for engaging a wall outlet 522 or other power source.

[0068] Although various illustrated embodiments herein employ particular sensors, it is to be noted that other approaches may be employed to detect the presence of a person or thing near a shredder, such as, for example, approaches utilizing eddy current, inductive, photoelectric, ultrasonic, Hall effect, or infrared proximity sensor technologies.

[0069] The foregoing illustrated embodiments have been provided to illustrate the structural and functional principles of the present invention and are not intended to be limiting. To the contrary, the present invention is intended to encompass all modifications, alterations and substitutions within the spirit and scope of the appended claims.

What is claimed is:

1. A shredder comprising:

a housing;

a shredder mechanism received in the housing and including an electrically powered motor and cutter elements, the shredder mechanism enabling articles to be shredded to be fed into the cutter elements and the motor being operable to drive the cutter elements so that the cutter elements shred the articles fed therein;

the housing having a movable part comprising a pair of spaced apart opposing walls providing at least part of an opening enabling articles to be fed therethrough into the cutter elements of the shredder mechanism for shredding, the movable part being movable from a first position to a second position and being biased to the first position;

a detector configured to detect movement of the movable part to the second position;

the movable part being constructed to move from the first position to the second position upon a user attempting to force an article having a thickness greater than a predetermined thickness through the opening, the predetermined distance being defined by a distance between the spaced apart opposing walls; and

a controller operable to perform a predetermined operation responsive to the detector detecting that the movable part has moved to the second position.

2. A shredder according to claim 1, wherein the detector comprises a switch that is actuated in response to the movable part moving to the second position.

3. A shredder according to claim 1, wherein the predetermined operation is illuminating an indicator.

4. A shredder according to claim 1, wherein the predetermined operation is sounding an alarm indicator.

5. A shredder according to claim 1, wherein the predetermined operation is disabling the cutter elements.

6. A shredder according to claim 1, wherein the controller comprises a microcontroller.

7-9. (canceled)

10. A shredder according to claim 1, further comprising at least one spring for biasing the moveable part to the first position.

11. A shredder according to claim 1, wherein the movable part includes a plunger.

12. A shredder according to claim 11, wherein the detector comprises a switch that is actuated by the plunger as the movable part moves to the second position.

13. A shredder according to claim 2, wherein the switch is a foil switch.

14. A shredder according to claim 2, wherein the switch is a lever switch.

15. A shredder according to claim 1, wherein the detector comprises a mechanical switch.

16. A shredder according to claim 1, wherein the detector comprises an optical detector.

17. A shredder according to claim 1, wherein the detector comprises a strain gauge configured and arranged to measure a movement of the movable part.

18. A shredder comprising:

a housing;

a shredder mechanism received in the housing and including an electrically powered motor and cutter elements, the shredder mechanism enabling articles to be shredded to be fed into the cutter elements and the motor being operable to drive the cutter elements so that the cutter elements shred the articles fed therein;

the housing having an opening enabling articles to be fed therethrough into the cutter elements of the shredder mechanism for shredding;

a resistive switch, at least in part located adjacent the opening and configured to indicate the presence of a person or animal in contact with the switch; and

a controller operable to perform a predetermined operation responsive to the indicated presence of the person or animal.

19. A shredder according to claim 18, wherein the predetermined operation is illuminating an indicator.

20. A shredder according to claim 18, wherein the predetermined operation is sounding an alarm indicator.

21. A shredder according to claim 18, wherein the predetermined operation is stopping the cutter elements.

22. A shredder according to claim 18, wherein the resistive switch further comprises a pair of electrically isolated conductive elements that, when simultaneously contacted by a part of the person or animal, are in electrical communication.

23. A shredder according to claim 18, wherein the controller is configured to monitor changes in signal strength from the switch over time, and to adjust a threshold value for performing the predetermined operation.

24. A shredder according to claim 18, wherein the controller is configured to perform the predetermined operation based at least in part on a rate of change of a monitored resistance of the resistive switch.

25. A shredder according to claim 18, wherein the controller is configured to perform the predetermined operation based at least in part on a monitored resistance of the resistive switch.

26. A device for use with a shredder, the shredder including a housing having an opening enabling articles to be fed therethrough into cutter elements of a shredder mechanism for shredding, the device comprising:

a switch, affixable to a portion of a shredder proximate the opening and configured to indicate the presence of a person or animal in contact with the switch;

a controller, in electrical communication with the switch, the controller having a connector constructed and arranged to engage a power supply and a receptacle constructed and arranged to accept a power cord of the shredder, the controller further being configured to provide power from the power supply to the shredder and to stop providing power to the shredder responsive to the indicated presence of the person or animal.

27. A device as in claim 26, wherein the switch is removably affixable to the shredder.

28. A device as in claim 26, wherein the switch is a capacitive switch.

29. A device as in claim 26, wherein the switch is a resistive switch.

30. A device as in claim 26, wherein the switch is a mechanical switch.

31. A device as in claim 30, wherein the mechanical switch is a pressure switch.

32. A shredder according to claim 1, wherein the walls of the movable part are parallel to one another.

33. A shredder according to claim 1, wherein the distance between the walls of the movable part varies.

34. A shredder according to claim 33, wherein the walls are angled inwardly towards one another.

35. A shredder according to claim 1, wherein the walls are joined together and move together with the movable part between the first and second positions.

36. A shredder according to claim 1, wherein the walls of the movable part move independently of one another.

37. A document shredder for shredding one or more data bearing documents selected from the group consisting of paper, optical discs, and floppy disks, comprising:

a housing;

a document shredder mechanism received in the housing and including an electrically powered motor and cutter elements, the document shredder mechanism enabling one or more data bearing documents selected from the group consisting of paper, optical discs, and floppy disks to be fed into the cutter elements and the motor being operable to drive the cutter elements so that the cutter elements shred the one or more documents fed therein;

the housing having an opening enabling the one or more data bearing documents to be fed therethrough into the cutter elements of the document shredder mechanism for shredding;

a discriminating proximity sensor comprising an electroconductive sensor element at least in part adjacent the opening, the proximity sensor being configured to indicate a presence of a person or animal, but not a presence of the one or more data bearing documents, in proximity to the opening based on the detection via the sensor element of an inherent electrical characteristic of the person or animal; and

a controller operable to disable the cutter elements responsive to the indicated presence of the person or animal.

38. A shredder according to claim 37, wherein the cutter elements are disabled by disabling power to the motor responsive to the indicated presence of the person or animal.

39. A shredder according to claim 37, wherein the proximity sensor is a capacitive sensor for detecting a capacitance between the sensor element and the person or animal.

40. A shredder according to claim 39, wherein:

the proximity sensor further comprises circuitry to sense a state of the electroconductive sensor element.

41. A shredder according to claim 40, wherein the electroconductive element is a thin metal member extending along a portion of the housing adjacent the opening.

42. A shredder according to claim 41, wherein the metal member is at least in part covered by a non-conductive member.

43. A shredder according to claim 40, wherein the electroconductive element at least in part comprises metal paint applied to a portion of the housing or to a member associated with the housing.

44. A shredder according to claim 40, wherein the electroconductive element includes at least two metal members each extending along a portion of the housing adjacent the opening.

45. A shredder according to claim 37, wherein the opening is an elongated, narrow opening.

46. A shredder according to claim 45, wherein the elongated, narrow opening is defined by a pair of opposing walls, and wherein the sensor element of the proximity sensor is attached to at least one of the walls.

47. A shredder according to claim 37, wherein:

wherein the proximity sensor further comprises circuitry to sense a state of the electroconductive sensor element.

48. A shredder according to claim 37, wherein the proximity sensor is configured to indicate the presence of the person or the animal in proximity to the opening without requiring contact with the sensor element.

49. A shredder according to claim 40, wherein the cutter elements are disabled by disabling power to the motor responsive to the indicated presence of the person or animal.

50. A shredder according to claim 37, further comprising a waste bin configured to receive shredded documents from the document shredder mechanism.

51. A shredder according to claim 50, wherein the waste bin is beneath the document shredder mechanism, the waste being manually removable from beneath the document shredder mechanism for emptying of the shredded documents therein.

52. A shredder according to claim 37, wherein the proximity sensor is a resistive sensor.

53. A document shredder for shredding one or more data bearing documents, comprising:

a housing;

a document shredder mechanism received in the housing and including an electrically powered motor and cutter elements, the document shredder mechanism enabling one or more data bearing documents to be fed into the cutter elements and the motor being operable to drive the cutter elements so that the cutter elements shred the one or more documents fed therein;

the housing having an opening enabling the one or more data bearing documents to be fed therethrough into the cutter elements of the document shredder mechanism for shredding;

a proximity sensor comprising an electroconductive sensor element at least in part adjacent the opening, the proximity sensor being configured to detect via the sensor element an inherent electrical characteristic of an object in proximity to the opening; and

a controller operable to disable the cutter elements responsive to detecting the inherent electrical characteristic as reaching a predetermined threshold.

54. A shredder according to claim 53, wherein the cutter elements are disabled by disabling power to the motor responsive to the indicated presence of the person or animal.

55. A shredder according to claim 53, wherein the proximity sensor is a capacitive sensor for detecting a capacitance between the sensor element and the person or animal.

56. A shredder according to claim 53, wherein the proximity sensor is configured to detect the inherent electrical characteristic of the object without requiring contact with the sensor element.

57. A shredder, comprising:

a housing;

a shredder mechanism received in the housing and including an electrically powered motor and cutter elements, the shredder mechanism enabling one or more articles to be fed into the cutter elements and the motor being operable to drive the cutter elements so that the cutter elements shred the articles fed therein;

the housing having an opening enabling the one or more articles to be fed therethrough into the cutter elements of the shredder mechanism for shredding;

a proximity sensor comprising an electroconductive sensor element at least in part adjacent the opening, the proximity sensor being configured to detect via the sensor element an inherent electrical characteristic of an object in proximity to the opening; and

a controller operable to disable the cutter elements responsive to detecting the inherent electrical characteristic as reaching a predetermined threshold.

58. A shredder according to claim 57, wherein the cutter elements are disabled by disabling power to the motor responsive to the indicated presence of the person or animal.

59. A shredder according to claim 57, wherein the proximity sensor is a capacitive sensor for detecting a capacitance between the sensor element and the person or animal.

60. A shredder according to claim 57, wherein the proximity sensor is configured to detect the inherent electrical characteristic of the object without requiring contact with the sensor element.

61. A method of operating a document shredder for shredding one or more data bearing documents selected from the group consisting of paper, optical discs, and floppy disks, the shredder comprising: (i) a housing; (ii) a document shredder mechanism received in the housing and including an electrically powered motor and cutter elements, the document shredder mechanism enabling one or more data bearing documents selected from the group consisting of paper, optical discs, and floppy disks to be fed into the cutter elements and the motor being operable to drive the cutter elements so that the cutter elements shred the one or more documents fed therein; (iii) the housing having an opening enabling the one or more data bearing documents to be fed therethrough into the cutter elements of the document shredder mechanism for shredding; (iv) a proximity sensor comprising an electroconductive sensor element at least in part adjacent the opening, the proximity sensor being configured to detect via the sensor element an inherent electrical characteristic of an object in proximity to the opening; and (v) a controller operable to control the cutter elements;

the method comprising:

feeding one or more data bearing documents selected from the group consisting of paper, optical discs, and floppy disks into the cutter elements via the opening;

operating the motor to drive the cutter elements so that the cutter elements shred the one or more documents fed therein;

detecting with the proximity sensor an object in proximity to the opening having an inherent electrical characteristic reaching a predetermined threshold; and

the controller disabling the cutter elements responsive to detecting the object having the inherent electrical characteristic reaching the predetermined threshold.

62. A method according to claim 61, wherein the detected object is a person or animal.

63. A method according to claim 61, wherein the cutter elements are disabled by disabling power to the motor responsive to detecting the object having the inherent electrical characteristic reaching the predetermined threshold.

64. A method according to claim 61, wherein the proximity sensor is a capacitive sensor and the inherent electrical characteristic detected is a capacitance between the sensor element and the object.

65. A method according to claim 62, wherein the proximity sensor is a capacitive sensor and the inherent electrical characteristic detected is a capacitance between the sensor element and the person or animal.

66. A method according to claim 61, wherein the proximity sensor detects the inherent electrical characteristic of the object without requiring contact with the sensor element.

67. A method of operating a shredder comprising: (i) a housing; (ii) a shredder mechanism received in the housing and including an electrically powered motor and cutter elements, the shredder mechanism enabling one or more articles to be shredded to be fed into the cutter elements and the motor being operable to drive the cutter elements so that the cutter elements shred the one or more articles fed therein; (iii) the housing having an opening enabling the one or more articles

to be fed therethrough into the cutter elements of the document shredder mechanism for shredding; (iv) a proximity sensor comprising an electroconductive sensor element at least in part adjacent the opening, the proximity sensor being configured to detect via the sensor element an inherent electrical characteristic of an object in proximity to the opening; and (v) a controller operable to control the cutter elements;

the method comprising:

feeding one or more articles into the cutter elements via the opening;

operating the motor to drive the cutter elements so that the cutter elements shred the one or more articles fed therein;

detecting with the proximity sensor an object in proximity to the opening having an inherent electrical characteristic reaching a predetermined threshold; and

the controller disabling the cutter elements responsive to detecting the object having the inherent electrical characteristic reaching the predetermined threshold.

68. A method according to claim 67, wherein the detected object is a person or animal.

69. A method according to claim 67, wherein the cutter elements are disabled by disabling power to the motor responsive to detecting the object having the inherent electrical characteristic reaching the predetermined threshold.

70. A method according to claim 67, wherein the proximity sensor is a capacitive sensor and the inherent electrical characteristic detected is a capacitance between the sensor element and the object.

71. A method according to claim 68, wherein the proximity sensor is a capacitive sensor and the inherent electrical characteristic detected is a capacitance between the sensor element and the person or animal.

72. A method according to claim 67, wherein the proximity sensor detects the inherent electrical characteristic of the object without requiring contact with the sensor element.

* * * * *