

E. C. JENKINS, Jr.

Ash Screen.

No. 111,126.

Patented Jan. 24, 1871.

*Fig. 1*

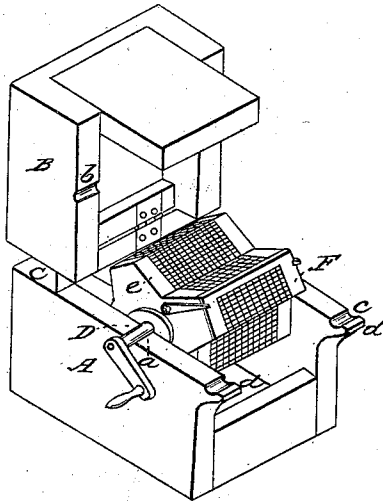

*Fig. 2*

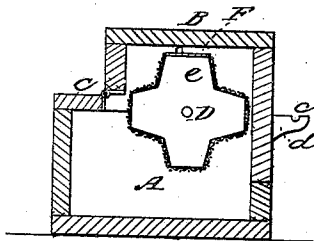

*Witnesses:*  
*Edw. Griffith.*  
*P. C. Headley.*

*Inventor:*  
*E. C. Jenkins Jr.*  
*by his Attorney*  
*Frederick Curtis.*

# United States Patent Office.

EBENEZER C. JENKINS, JR., OF WORCESTER, MASSACHUSETTS.

Letters Patent No. 111,126, dated January 24, 1871.

## IMPROVEMENT IN ASH-SCREENS.

The Schedule referred to in these Letters Patent and making part of the same.

To all to whom these presents shall come:

Be it known that I, EBENEZER C. JENKINS, Jr., of the city and county of Worcester and State of Massachusetts, have made an invention of a certain novel and useful Screen for Ashes; and do hereby declare the following to be a full, clear, and exact description thereof, due reference being had to the accompanying drawing making part of this specification, and in which—

Figure 1 is a perspective elevation of my invention, with its cover raised to expose its interior,

Figure 2 being a longitudinal and vertical section of the same, with its cover closed.

The purpose of my invention is to produce a sifter for household use, which shall enable the disagreeable duty of sifting ashes to be neatly and expeditiously as well as easily performed, the said invention consisting, mainly, in the peculiar form of the revolving screen or cage; and, secondly, in its combination with the inclosing and ash-receiving box or case of the device, whereby the removal of the coal after sifting is effected with the expenditure of very little labor, substantially as hereinafter explained.

The drawing accompanying this specification and illustrating my invention represents, at A, a cubical box or case, provided with a raised deep cover, B, of somewhat less length, and hinged to a narrow shelf, C, bridging the rear end of the box, the front end of such cover being prolonged to such an extent as to partially close the front end of the said box.

Within the box A I dispose a rotary screen or cage, E, which is mounted upon a horizontal shaft, D, disposed in open semicircular bearings *a a*, formed in the upper edges of the sides of the box, and transversely thereof, the lower edges of opposite sides of the cover being provided with like bearings *b b*, coinciding with the bearings *a a*, and serving, in connection with them, when the cover is closed, to maintain the shaft and screen in proper place and permit them to freely revolve.

The circumference of the rotary screen is indented or irregular, or formed with angular irregularities, as shown in fig. 2 of the drawing, in order not only to obtain greater extent of screening-surface in a given diameter, but to create a great disturbance and separation of the ashes and coal, since, were it not for the angles and corners of the screen, the centrifugal force generated by the revolution of the screen would throw the coal in large quantities to the outside of the screen, and the ashes, to a great extent, to the center, and thus defeat the main object of this invention.

As, owing to the diversified circumference, and especially to the angular corners *a a* of the sifter or screen E, a very slow rotation only is necessary, no

centrifugal force of any account is generated, and the separation of the coal and ashes and escape of the latter are effected with very little labor and in an incredibly short space of time.

The periphery of the cage or sifter *e* is provided with a door, F, for enabling ashes to be introduced, and the screened coal to be subsequently removed.

The size of the said sifter *e* should, in practice, be sufficient to contain the ashes made by ordinary families in a fortnight, or thereabout; and such sifter should be suffered to remain in a position with its door uppermost, and open until filled, or nearly so, by the ashes which have been dumped through its open door, the cover of the case A, as a matter of course, being open.

When the screen is nearly or quite filled, its door F is to be closed and the cover of the box A shut, the screen being then slowly rotated a few times, which will precipitate the ashes to the bottom of the box and retain the coal and slag within the screen.

The dust having subsided within the box, its cover is to be opened, and the screen *e* trundled or pushed along the upper edges of the sides of the box until its shaft reaches and drops into two oppositely-disposed shallow bearings *c c*, created in ears *d d*, extending from or making part of the extreme end of each side of the box, the length of these ears and the situation of the bearings *c c* being such as to bring the greater part of the screen outside said box.

When in this position the door of the screen should be underneath, and upon opening it the coal and slag will be precipitated therefrom into a suitable vessel placed to receive them.

It is believed that a sifter constructed as above described will sift ashes or other substances in a much quicker and easier manner than by any device heretofore known, and for these reasons is believed to possess considerable value for the public.

Having thus explained the nature, purposes, and advantages of my invention,

I claim as such, and desire to secure by Letters Patent of the United States, the following, that is to say—

The herein-described screen, composed of the case A and the rotary sifter or screen *e*, the box being provided with the overhanging bearings *c c*, and the screen, with the irregular undulating surface, and the door F, the whole operating in manner as before explained

E. C. JENKINS, JR.

Witnesses:

FRED. CURTIS,  
EDW. GRIFFITH.