

No. 875,175.

PATENTED DEC. 31, 1907.

W. H. HESS.
AIR AND GAS MIXER.
APPLICATION FILED JUNE 4, 1907.

2 SHEETS—SHEET 1.

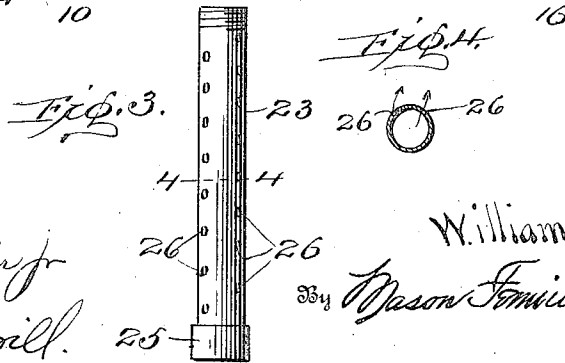
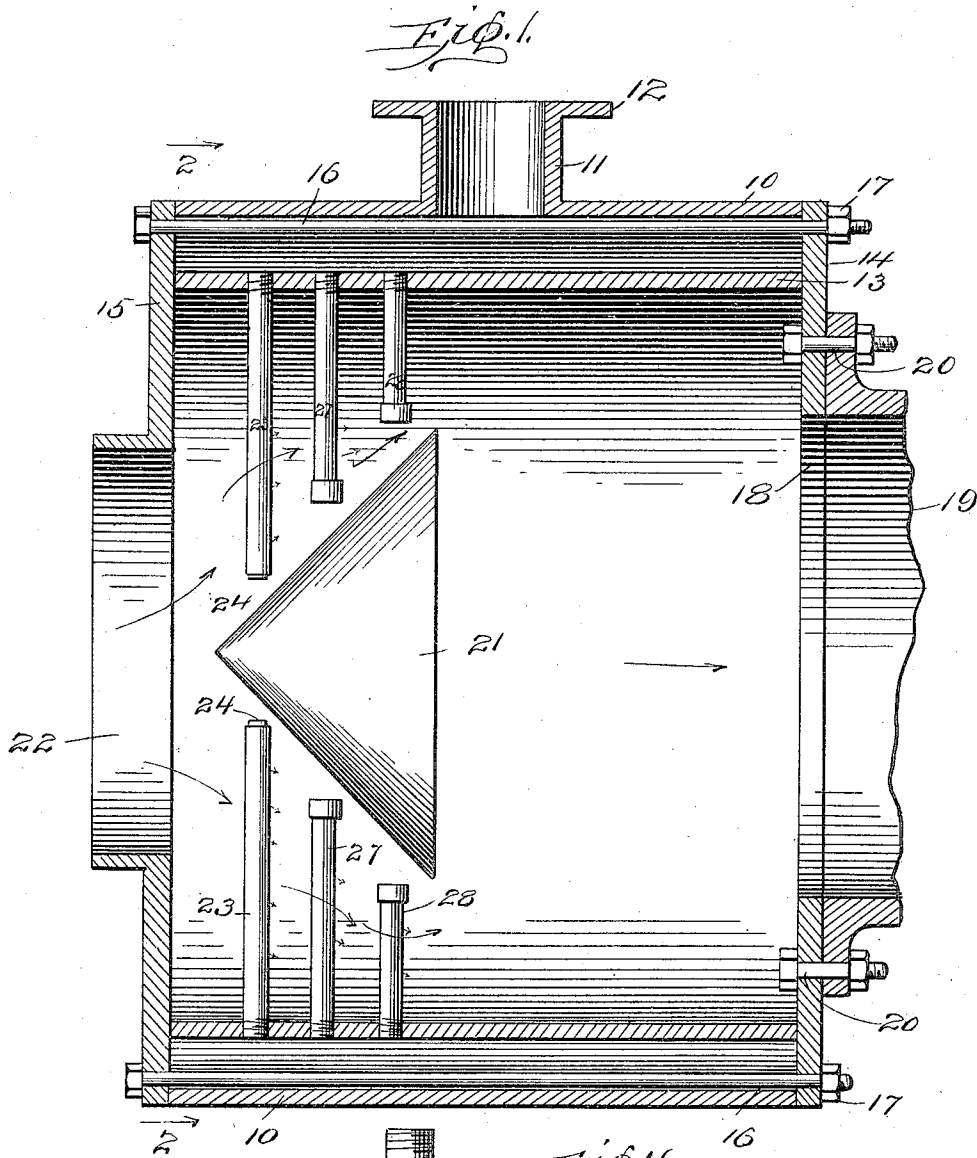

Witnesses
J. M. Fowler
L. D. Morrill

Inventor,
 William H. Hess,
Mason Farnick Lawrence,
 Attorneys

No. 875,175.

PATENTED DEC. 31, 1907.

W. H. HESS.
AIR AND GAS MIXER.
APPLICATION FILED JUNE 4, 1907.

2 SHEETS—SHEET 2.

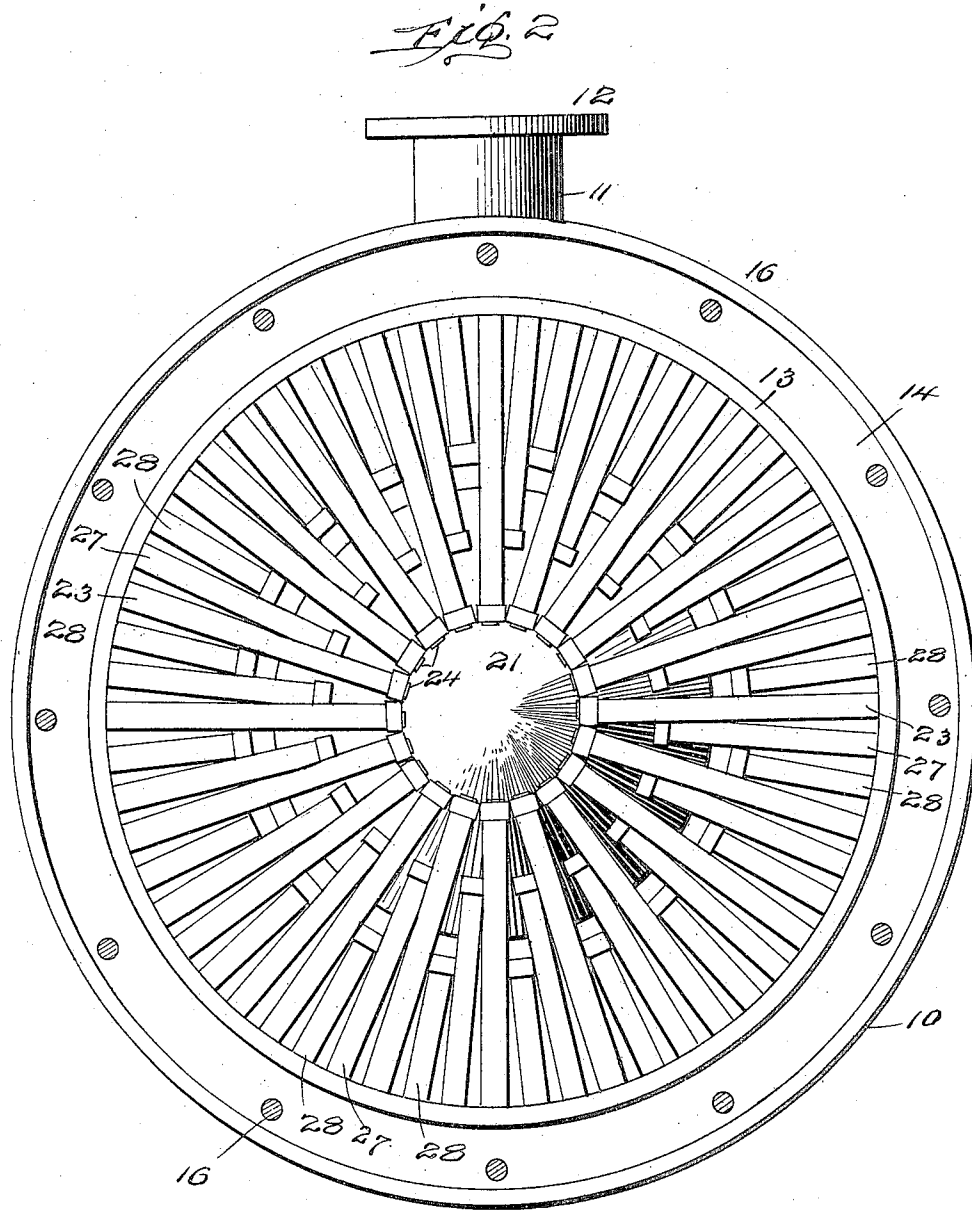

Inventor

William H. Hess

Witnesses

J. M. Fowler Jr.
L. E. Morrill.

By *Mason Fenwick Lawrence,*
Attorneys

UNITED STATES PATENT OFFICE.

WILLIAM H. HESS, OF DEWEY, OKLAHOMA, ASSIGNOR OF ONE-HALF TO HERBERT F. TYLER,
OF JUNCTION CITY, KANSAS.

AIR AND GAS MIXER.

No. 875,175.

Specification of Letters Patent.

Patented Dec. 31, 1907.

Application filed June 4, 1907. Serial No. 377,278.

To all whom it may concern:

Be it known that I, WILLIAM H. HESS, a citizen of the United States, residing at Dewey, in the Cherokee Nation, State of Oklahoma, have invented certain new and useful Improvements in Air and Gas Mixers; and I do hereby declare the following to be a full, clear, and exact description of the invention, such as will enable others skilled in the art to which it appertains to make and use the same.

This invention relates to air and gas mixers, and has for an object to provide a device especially adapted for feeding very large volumes of gaseous fuel and to provide improved means for a thorough mixing of the gaseous fuel with air.

A further object of the invention is to provide in a mixer means for introducing a gaseous fuel into a current of air in a very large number of jets and with a baffle properly disposed to thoroughly mix and commingle the gas and air.

With these and other objects in view, the invention comprises certain novel constructions, combinations and arrangements of parts, as will be hereinafter fully described and claimed.

In the drawings:—Figure 1 is a diametrical, vertical, sectional view of the improved gas mixer. Fig. 2 is an end view of the mixer with one of the heads removed as taken on line 2—2 of Fig. 1. Fig. 3 is a view in side elevation of one of the gas tubes. Fig. 4 is a view in transverse section of the gas tube taken on line 4—4 of Fig. 3.

Like characters of reference designate corresponding parts throughout the several views.

The improved gas mixer forming the subject-matter of this application comprises a cylinder 10 having an inlet 11 preferably provided with a flange 12 for connection with a supply pipe in the usual well known manner.

Within the cylinder 10 a concentric cylinder 13 is disposed defining an annular chamber between the two cylinders. The cylinders are held in the proper position and the chamber between the cylinders further defined by means of heads 14 and 15, clamped together upon opposite ends of the said cylinders in any approved manner as by bolts 16, and clamping nuts 17.

The head 14 is provided with an opening

18 positioned and proportioned to register with a pipe 19 secured thereto in any approved manner, as by the bolts 20 and providing means for the discharge of gas and air from the mixing chamber.

Concentrically within the cylinder 13 a conical baffle 21 is disposed having its base opposite the opening 18 and its apex directed toward an opening 22 through which air is forced to the mixing chamber within the chamber 13.

Adjacent the head 15 through which is formed the opening 22 a plurality of pipes 23 are positioned having one end inserted through the cylinder 13 and in communication with the chamber between the cylinders 10 and 13, and its opposite end closed in any approved manner as by the lug 24 or cap 25. The pipes 23 are each provided with a plurality of openings 26 disposed upon the side opposite the air opening 22 and preferably formed in one or more rows extending longitudinally of the pipe 23 and with the openings directed toward the baffle 21 and opening 18.

Adjacent the pipes 23 a plurality of pipes 27 are also inserted through the cylinder 13 and in communication with the annular chamber and are closed at their opposite ends and supplied with openings similar to the closing and opening of pipes 23 above described. Adjacent the pipes 27 are also mounted pipes 28 similar to the pipes 23 and 27, the pipes 27 being shorter than the pipes 23 and the pipes 28 shorter than the pipes 27, with their lengths related to conform substantially with the inclination of the baffle 21, as more particularly shown in Fig. 1. It will thus be seen that a very large number of pipes are in communication with the annular chamber between the casings 10 and 13 and that each of said pipes are provided with a very large number of small openings so that the gas from the annular chamber is discharged in a multitude of very fine jets in the direction of the air current passing through the opening 22 so that the said gases are thoroughly mixed with the air entering through the opening 22 and deflected by the baffle 21 before such air and commingled gases pass outwardly through the opening 18 and pipe 19.

It will be noted that between the baffle 21 and the opening 18 a chamber of some considerable proportion is provided to allow the

further and more thorough commingling and mixing of the gases and the air before being discharged through the pipe 19 to the burner.

What I claim is:—

5 1. In a device of the class described, concentric shells defining a chamber, means to admit gas to the chamber, pipes extending radially from the inner shell toward but stopping short of the center, an air inlet adjacent
10 the pipes, and a baffle positioned to deflect air from the inlet and gas from the pipes.

2. In a device of the class described, spaced casings provided with an air inlet through one end, and an air outlet through
15 the opposite end communicating with the interior of the inner casing, means to admit gas between the casings, pipes inserted through the inner casings and extending toward the center and with outlet openings
20 formed in the pipes upon their sides opposite the air inlet.

3. In a device of the class described, concentric casings defining an annular chamber, and with an air inlet through one end and an
25 air outlet through the opposite end communicating with the interior of the inner casing, means to admit gas to the chamber, pipes inserted through the inner casing and in communication with the annular chamber,
30 and with outlet openings formed upon their sides opposite the air inlet, and a baffle disposed adjacent the pipes.

4. In a device of the class described, concentric cylinders spaced apart and defining
35 an annular chamber therebetween, and with an air inlet through one end and an air outlet through the opposite end communicating with the interior of the inner casing, means to admit gas to the chamber, tubes inserted
40 through the inner casing and in communica-

tion with the annular chamber and disposed adjacent the air inlet, and a baffle disposed within the inner cylinder adjacent to the pipes but on the side opposite the air inlet.

5. In a device of the class described, concentric cylinders spaced apart and defining
45 an annular chamber therebetween, and provided with a gas inlet, heads formed upon opposite ends of the cylinder, and one provided with an air inlet and the other with an
50 air outlet, a baffle disposed within the cylinder and adjacent the air inlet, and pipes inserted through the inner cylinder and in communication with the annular chamber, and between the air inlet and the baffle, said
55 pipes being provided with gas outlets upon their sides opposite the air inlet.

6. In a device of the class described, concentric cylinders defining a gas chamber therebetween, and with means for admitting
60 gas thereto, heads secured upon opposite ends of the cylinders and one provided with an air inlet and the other with an air outlet, a conical baffle disposed within and co-axial with the inner cylinder, and with its apex
65 pointed toward and adjacent to the air inlet, a plurality of tubes inserted through the inner cylinder and in communication with the annular chamber, said pipes varying in
70 length and with their inner ends adjacent to the inclined sides of the baffle and with openings formed along their sides opposite the air inlet.

In testimony whereof I affix my signature in presence of two witnesses.

WILLIAM H. HESS.

Witnesses:

THOS. M. PRICE,

ALBERT D. PRICE.