

FOR THE PURPOSES OF INFORMATION ONLY

Codes used to identify States party to the PCT on the front pages of pamphlets publishing international applications under the PCT.

AL	Albania	ES	Spain	LS	Lesotho	SI	Slovenia
AM	Armenia	FI	Finland	LT	Lithuania	SK	Slovakia
AT	Austria	FR	France	LU	Luxembourg	SN	Senegal
AU	Australia	GA	Gabon	LV	Latvia	SZ	Swaziland
AZ	Azerbaijan	GB	United Kingdom	MC	Monaco	TD	Chad
BA	Bosnia and Herzegovina	GE	Georgia	MD	Republic of Moldova	TG	Togo
BB	Barbados	GH	Ghana	MG	Madagascar	TJ	Tajikistan
BE	Belgium	GN	Guinea	MK	The former Yugoslav Republic of Macedonia	TM	Turkmenistan
BF	Burkina Faso	GR	Greece	ML	Mali	TR	Turkey
BG	Bulgaria	HU	Hungary	MN	Mongolia	TT	Trinidad and Tobago
BJ	Benin	IE	Ireland	MR	Mauritania	UA	Ukraine
BR	Brazil	IL	Israel	MW	Malawi	UG	Uganda
BY	Belarus	IS	Iceland	MX	Mexico	US	United States of America
CA	Canada	IT	Italy	NE	Niger	UZ	Uzbekistan
CF	Central African Republic	JP	Japan	NL	Netherlands	VN	Viet Nam
CG	Congo	KE	Kenya	NO	Norway	YU	Yugoslavia
CH	Switzerland	KG	Kyrgyzstan	NZ	New Zealand	ZW	Zimbabwe
CI	Côte d'Ivoire	KP	Democratic People's Republic of Korea	PL	Poland		
CM	Cameroon	KR	Republic of Korea	PT	Portugal		
CN	China	KZ	Kazakstan	RO	Romania		
CU	Cuba	LC	Saint Lucia	RU	Russian Federation		
CZ	Czech Republic	LI	Liechtenstein	SD	Sudan		
DE	Germany	LK	Sri Lanka	SE	Sweden		
DK	Denmark	LR	Liberia	SG	Singapore		
EE	Estonia						

TITLE OF THE INVENTION

INDUSTRIAL FIBERS WITH DIAMOND CROSS SECTIONS AND
PRODUCTS MADE THEREFROM

5

BACKGROUND OF THE INVENTION

1. Field of the Invention.

This invention relates to industrial fibers and products made therefrom and more specifically to industrial polyester fibers and products made therefrom.

2. Description of Related Art.

Industrial (i.e., high strength) fibers and multifilament yarns are well-known, including yarns comprising polyester. Such yarns have been manufactured and used commercially for more than 30 years.

Industrial polyester fibers are typically made from poly(ethylene terephthalate) polymer having a relative viscosity of about 24 to about 42, a denier per filament (dpf) of about 4 to about 8, and a tenacity of about 6.5 grams/denier to about 9.2 grams/denier. These characteristics of relative viscosity, denier and tenacity distinguish, in part, yarns described as having "industrial properties" from polyester apparel yarns of lower relative viscosity and lower denier and consequently of significantly lower strength (i.e., tenacity). Industrial polyester yarns having these properties, and processes for producing the yarns, are disclosed in U.S. Patent 3,216,187 to Chantry et al.

It is also known to prepare industrial polyester yarns of varied shrinkage by a continuous process involving spinning, hot-drawing, heat-relaxing, interlacing and winding the yarn to form a package in a coupled process. U.S. Patent 4,003,974 to Chantry et al. disclose such a coupled continuous process for making polyethylene terephthalate multifilament yarns having a maximum dry heat shrinkage of 4% and an elongation to

break in the range of 12% to 20%. Combined with the relative viscosity, denier range and tenacity cited above, these shrinkage and elongation to break properties comprise the distinguishing features of yarns with
5 "industrial properties".

U.S. Patent 4,622,187 to Palmer discloses a continuous coupled-process for making polyester yarns of very low shrinkage of about 2%, with other properties suitable for industrial multifilament yarn applications.

10 Each of the Patents cited above disclose filaments, or multifilament yarns made of filaments, having circular cross-sections normal to their longitudinal axes. For use in apparel applications, it has been proposed to use fibers having non circular cross sections with lower
15 strength than needed for industrial applications. However, to date, all commercial industrial fibers have circular cross sections. In fact, the inventors know of no prior art disclosing an industrial polyester multifilament yarn having a multifilament yarn denier
20 range of about 600 to about 2000 with filaments other than round cross-section.

It is an object of this invention to provide industrial fibers, multifilament industrial yarns and fabrics with improved cover power which reduce the weight
25 of a fabric made from the yarns per unit area without significantly reducing the industrial properties thereof.

These and other objects of the invention will be clear from the following description.

30

SUMMARY OF THE INVENTION

The invention relates to an industrial filament, comprising a synthetic melt spun polymer having a relative viscosity of about 24 to about 42, a denier of about 4 to about 8, a tenacity of about 6.5 grams/denier
35 to about 9.2 grams/denier, and an elongated diamond shaped cross section normal to a longitudinal axis of the

filament, the cross section having an aspect ratio of about 2 to about 6.

The invention is further directed to industrial multifilament yarns, fabrics and other products employing
5 industrial filaments as described herein.

BRIEF DESCRIPTION OF THE DRAWINGS

The invention can be more fully understood from the following detailed description thereof in connection with
10 accompanying drawings described as follows.

Figure 1 is a schematic enlarged view, illustrating various measurement parameters, of an industrial filament cut normal to its longitudinal axis showing an elongated diamond shaped cross section in accordance with the
15 invention.

Figure 2 is a schematic enlarged view of a tile arrangement of filaments as shown in Figure 1 in an industrial yarn cut normal to its longitudinal axis.

Figure 3 is a schematic enlarged view of a prior art arrangement of filaments having round cross sectional shapes in an industrial yarn cut normal to its
20 longitudinal axis.

Figure 4 is a schematic enlarged view of an industrial yarn cut normal to its longitudinal axis in
25 accordance with the present invention.

Figure 5 is a schematic enlarged view of one embodiment of a fabric in accordance with the present invention.

Figure 6 is a view of a spinneret orifice in a spinneret for spinning the filaments shown in Figure 1.
30

Figure 7 is a cross sectional view generally along line 7-7 of the spinneret shown in Figure 6 in the direction of the arrows.

Figures 8A and 8B illustrate a first double diamond shaped spinneret orifice and a first double diamond
35 shaped cross section of a filament formed by spinning

polymer through the first double diamond shaped spinneret orifice.

Figures 9A and 9B illustrate a second double diamond shaped spinneret orifice and a second double diamond shaped cross section of a filament formed by spinning
5 polymer through the second double diamond shaped spinneret orifice.

Figure 10 is a schematic illustration of a spinning machine for producing yarns comprising the filaments
10 shown in Figure 1.

Figures 11A and 11B illustrate an "S" shaped spinneret orifice and an "S" shaped cross section of a filament formed by spinning polymer through the "S" shaped spinneret orifice.

Figures 12A and 12B illustrate a hollow bilobal shaped spinneret orifice and a hollow bilobal cross section of a filament formed by spinning polymer through the hollow bilobal shaped spinneret orifice.

Figures 13A and 13B illustrate a hollow oval shaped spinneret orifice and a hollow oval cross section of a filament formed by spinning polymer through the hollow oval shaped spinneret orifice.

Figures 14A and 14B illustrate a flat ribbon shaped spinneret orifice and a flat ribbon cross section of a filament formed by spinning polymer through the flat ribbon shaped spinneret orifice.

Figures 15A and 15B illustrate a circular shaped spinneret orifice and a circular cross section of a filament formed by spinning polymer through the circular shaped spinneret orifice.

DESCRIPTION OF THE PREFERRED EMBODIMENT(S)

Throughout the following detailed description, similar reference characters refer to similar elements in
35 all figures of the drawings.

The present invention is directed to an industrial filament 10 having an elongated diamond shaped cross section 12 and products made therefrom including multifilament yarns and fabrics.

5

1. Filaments

For purposes herein, the term "filament" is defined as a relatively flexible, macroscopically homogeneous body having a high ratio of length to cross-sectional area. Herein, the term "fiber" shall be used interchangeably with the term "filament".

10

A. Cross Section

Referring to Figure 1, there is illustrated an industrial filament 10 cut normal to its longitudinal axis showing an elongated diamond shaped cross section 12 in accordance with the invention. The elongated diamond cross section 12 has a periphery 14 comprising, in a clockwise direction in Figure 1, a first substantially straight side 16, an first obtuse rounded corner 18, a second substantially straight side 20, an first acute rounded corner 22, a third substantially straight side 24, a second obtuse rounded corner 26, a fourth substantially straight side 28, a second acute rounded corner 30. Preferably, the four sides 16,20,24,28 are of equal or substantially equal length. The obtuse rounded ends 18,26 are on opposite sides of the periphery 14. Similarly, the acute rounded ends 22,30 are on opposite sides of the periphery 14. The obtuse rounded ends 18,26 are described as "obtuse" since they connect to sides (16,20 and 24,28, respectively) forming an obtuse angle between them. Similarly, the acute rounded ends 22,30 are described as "acute" since they connect to sides (20,24 and 16,28, respectively) forming an acute angle between them. The obtuse angles defining the obtuse rounded ends 18,26 do not need to be the same, but

20

30

35

preferably are. Similarly, the acute angles defining the acute rounded ends 22,30 do not need to be the same, but preferably are.

The cross-sectional shape of a filament 10 can be quantitatively described by its aspect ratio (A/B). The term "aspect ratio" has been given various definitions in the past. Herein, when applied to cross sections filaments, the term "aspect ratio" is defined as a ratio of a first dimension (A) to a second dimension (B). The first dimension (A) is defined as a length of a straight line segment connecting first and second points in the periphery 14 of the filament cross section 12 that are farthest from one another. The first dimension (A) can also be defined as the diameter of a smallest circle 32 that will enclose the cross section 14 of the filament 10. The second dimension (B) is a maximum width of the cross section 12 extending at right angles to the straight line segment. In the elongated diamond cross section 12, the first dimension (A) and the second dimension (B) extend entirely within and along the cross section 12 of the filament 10. The aspect ratio of the elongated diamond cross section 12 of the present invention is about 2 to about 6, and preferably about 3.5 to about 4.5.

Industrial filaments with cross sections made from multiple elongated cross-sectional areas joined together are within the scope of this invention. Figure 8B illustrates such filaments 800 comprising first double diamond shaped cross sections 812 having a pair of elongated diamond cross sectional areas joined together at their acute rounded corners. Figure 9B illustrates such filaments 900 comprising second double diamond shaped cross sections 912 having a pair of elongated diamond cross sectional areas joined together at their obtuse rounded corners.

B. Polymers

The filaments 10,800,900 can be made from any and all types of synthetic polymers and mixtures thereof which are capable of being melt spun into filaments
5 having industrial properties as specified herein. Preferably, the polymers are polyesters or polyamides.

Polyester polymer is used in this application to refer to polyester homopolymers and copolymers which are composed of at least 85% by weight of an ester of a
10 dihydric alcohol and terephthalic acid. Some useful examples of polyesters and copolyesters are shown in U.S. Patents 2,071,251 (to Carothers), 2,465,319 (to Whinfield and Dickson), 4,025,592 (to Bosley and Duncan), and 4,945,151 (to Goodley and Taylor). Most preferably, the
15 polyester polymer used to make the filaments should be essentially 2G-T homopolymer, i.e., poly(ethylene terephthalate).

Nylon polymer is used in this application to refer to polyamide homopolymers and copolymers which are
20 predominantly aliphatic, i.e., less than 85% of the amide-linkages of the polymer are attached to two aromatic rings. Widely-used nylon polymers such as poly(hexamethylene adipamide) which is nylon 6,6 and poly(ϵ -caproamide) which is nylon 6 and their copolymers
25 can be used in accordance with the invention. Other nylon polymers which may be advantageously used are nylon 12, nylon 4,6, nylon 6,10 and nylon 6,12. Illustrative of polyamides and copolyamides which can be employed in the process of this invention are those described in U.S.
30 Patents 5,077,124, 5,106,946, and 5,139,729 (each to Cofer et al.) and the polyamide polymer blends disclosed by Gutmann in Chemical Fibers International, pages 418-420, Volume 46, December 1996.

The polymers and resulting filaments 10,800,900,
35 yarns and fabrics may contain the usual minor amounts of such additives as are known in the art, such as

delustrants or pigments, light stabilizers, heat and oxidation stabilizers, additives for reducing static, additives for modifying dye ability, etc. Also as known in the art, the polymers must be of filament-forming
5 molecular weight in order to melt spin into yarn.

C. Relative Viscosity

Polymers having relative viscosity of about 24 to about 42, preferably about 36 to about 38, have been
10 found to give very good results as indicated hereinafter in the Examples.

D. Denier

The filaments of the present invention have a denier
15 per filament (dpf) of about 4 to about 8 (about 4.4 dtex to about 8.9 dtex), and preferably about 6 to about 7.2 (about 6.6 dtex to about 8.0 dtex). These deniers are preferably measured deniers as described herein. Preferably, the measured deniers are "as spun" measured
20 average deniers which includes yarn finish and ambient moisture as described herein.

E. Tenacity

The filaments 10,800,900 of the present invention
25 have a tenacity of about 6.5 grams/denier to about 9.2 grams/denier, and preferably a tenacity of about 7.5 grams/denier to about 8.0 grams/denier.

F. Other Properties

30 The filaments 10,800,900 of the present invention have a dry heat shrinkage of about 2% to about 16% at 30 minutes at 177°C, and preferably a dry heat shrinkage of about 3% to about 13% at 30 minutes at 177°C.

The filaments 10,800,900 of the present invention
35 have an elongation to break in the range of 16% to 29%, and preferably of 17% to 28%.

2. Yarns

A yarn comprises a plurality (typically 140-192) of the industrial filaments 10,800,900 having a degree of cohesion. The filaments 10,800,900 in a yarn are preferably intermingled and tangled through an intermingling device or otherwise. A typical intermingling device and process is disclosed in U.S. Patent 2,985,995 and is suitable for use in the manufacture of the instant yarns. During the spinning process, the filaments 10,800,900 with elongated diamond cross sections 12,812,912 have a tendency to naturally intermingle without the aid of an intermingling device. The term "yarn" as used herein includes continuous filaments and staple filaments, but are preferably continuous filaments. The filaments 10,800,900 are "continuous" meaning that the length of the filaments making up the yarn are the same length as the yarn and are substantially the same length as other filaments in the yarn, in contrast to filaments in a yarn that are discontinuous which are often referred to as staple filaments or cut filaments formed into longer yarns much the same way that natural (cotton or wool) filaments are.

Due to the unique diamond cross section of the filaments 10, some of the filaments 10 in a yarn typically position themselves in a tile arrangement such that oblique ends 18,26 of the cross sections 12 in a first row 36 of the filaments 10 are near acute ends 22,30 of the cross sections 12 of filaments 10 in rows 38,40 of the filaments 10 on both sides of the first row 36. As can be seen comparing this tile arrangement illustrated in Figure 2 to the most compact arrangement of prior art industrial filaments illustrated in Figure 3 which have substantially the same cross sectional area as those in Figure 2, the tile arrangement of the filaments 10 with the elongated diamond cross sections 12 are more

dense (i.e., have smaller void areas 42). Further, comparing the tile arrangement in Figure 2 to the prior art arrangement in Figure 3, one can see that the tile arrangement of the filaments 10 with the elongated diamond cross sections 12 provide a greater covering power than the compact arrangement of the filaments with round cross sections. The term "covering power" means that the same volume or weight of filaments 10 with the elongated diamond cross sections 12 covers or extends over a larger surface (left to right in Figures 2 and 3) than the arrangement of the filaments with round cross sections having areas the same as or substantially the same as the areas of the elongated diamond cross sections 12. Thus, the tapering outward shape the filaments 10 with diamond cross sections 12 give a bundle of the filaments 10 a tendency to spread out along a surface in a substantially even manner increasing the covering power or property when used, instead of filaments with round cross sections of similar construction and weight and having the same or substantially the same cross sectional area per filament.

Figure 4 is a schematic enlarged view of a portion of an industrial yarn 44 cut normal to its longitudinal axis in accordance with the present invention. The tile arrangement illustrated in Figure 2 can be seen throughout the yarn cross section in Figure 4.

3. Fabric

The invention is further directed to industrial fabric 52 that includes at least one of the industrial yarns with at least some of the industrial filaments 10 in accordance with the invention. The filaments 10 produced in accordance with the present invention may be employed as yarns and converted, e.g., by weaving into fabric patterns of any conventional design by known methods. Furthermore, these bodies may be combined with

other known filaments to produce mixed yarns and fabrics. Fabrics woven or knitted from the filaments 10 produced in accord with this invention have increased covering power and reduced weight as compared to fabrics of similar construction and weight made from round filaments having the same cross sectional area per filament.

In one embodiment illustrated in Figure 5, the woven industrial fabric 52 comprises a plurality of first industrial yarns 54 in a warp direction, a plurality of second industrial yarns 56 in a fill direction weaved with the first industrial yarns 54, and at least some of the first industrial yarns 54 and/or at least some of the second industrial yarns 56 comprising a plurality of the industrial filaments 10. Preferably, at least the first industrial yarns 54 or the second industrial yarns 56 comprise a plurality of the industrial filaments 10. In this preferred case, the fabric 52 can have a reduction in total weight by at least 7% compared to a fabric made entirely from yarns comprising other filaments which are essentially the same as the industrial filaments 10, except the other filaments having circular cross sections. A range for fabric weight reduction (compared to a fabric made entirely from yarns comprising other filaments which are essentially the same as the industrial filaments 10, except the other filaments having circular cross sections) is from about 5% to about 15%.

In a second embodiment, the woven industrial fabric 52 comprises a plurality of first industrial yarns 54 in a warp direction, a plurality of second industrial yarns 56 in a fill direction weaved with the first industrial yarns 54, and at least some of the first industrial yarns 54 and at least some of the second industrial yarns 56 comprising a plurality of the industrial filaments 10. In this case, the fabric 52 can have a reduction in total weight by at least 10% compared to a fabric entirely made

from yarns comprising other filaments which are essentially the same as the industrial filaments 10, except the other filaments having circular cross sections. In this case, a range for fabric weight reduction is from about 10% to about 30%.

4. Spinnerets

Figures 6 and 7 illustrate a spinneret 60 for use in the melt extrusion of a polymer to produce the industrial filaments 10 having elongated diamond cross sections 12 in accordance with the present invention. The spinneret 60 comprises a plate 62 having an assembly of orifices, capillaries or holes 64 through which molten polymer is extruded to form the industrial filaments 10. Figure 6 shows a bottom view of one of the orifices, capillaries or holes 64 having an elongated diamond shape or cross section 66 through the plate 62. In Figure 6, the elongated cross section 66 is normal to its longitudinal axis passing normal through the sheet of drawings. Figure 7 is a cross sectional view generally along line 7-7 of the spinneret 60 shown in Figure 6 in the direction of the arrows. As illustrated in Figure 7, each hole 64 has two sections: a capillary 66 itself and a much larger and deeper counter bore passage 70 connected to the capillary 66.

The elongated diamond cross section 66 of the capillary 68 has a periphery 71 comprising, in a clockwise direction in Figure 6 and joined to one another, a first substantially straight side 72, an first obtuse corner 73, a second substantially straight side 74, an first acute corner 75, a third substantially straight side 76, a second obtuse corner 77, a fourth substantially straight side 78, a second acute corner 79 joined to the substantially straight side 72. Preferably, the four sides 72,74,76,78 are of equal or substantially equal length. The obtuse ends 73,77 are on

opposite sides of the periphery 71. Similarly, the acute ends 75,79 are on opposite sides of the periphery 71. The obtuse ends 73,77 are described as "obtuse" since they connect to sides (72,74 and 76,78, respectively) forming an obtuse angle between them. Similarly, the acute ends 75,79 are described as "acute" since they connect to sides (74,76 and 72,78, respectively) forming an acute angle between them. The obtuse angles defining the obtuse ends 73,77 do not need to be the same, but preferably are. Similarly, the acute angles defining the acute ends 75,79 do not need to be the same, but preferably are.

The cross-sectional shape 66 of the capillary 68 can also be quantitatively described by its aspect ratio (A/B). Herein, when applied to cross sections of capillaries, the term "aspect ratio" is defined as a ratio of a first dimension (A) to a second dimension (B). The first dimension (A) is defined as a length of a straight line segment connecting a first point and a second point in the periphery 71 of the capillary cross section 66 that are farthest from one another. The first dimension (A) can also be defined as the diameter of a smallest circle that will enclose the cross section 66 of the capillary 68. The second dimension B is a maximum width of the cross section 66 extending at right angles to the straight line segment. In the elongated diamond cross section 66, the first dimension (A) and the second dimension (B) extend entirely within and along the cross section 12 of the capillary 68. The aspect ratio of the elongated diamond cross section 66 of the capillaries 68 of the present invention is about 8 to about 26, and preferably about 15 to about 20.

The spinneret 60 used in the production of filaments 10 of the present invention may be of any conventional material employed in spinneret construction for melt-spinning. The stainless steels are especially suitable.

Each spinneret 60 may have from one to several thousand individual holes 64. The hole layout, or array, is carefully designed to keep filaments properly separated, to permit each filament 10 the maximum unobstructed exposure to quench air, and to assure that all filaments 10 are treated as nearly equal as possible.

The counter bore passage 70 can be formed by drilling. However, the capillaries 66 must be fabricated to precise dimensions such as with laser capillary machine.

The shape of the spinneret capillary 66 determines the shape of the spun filament 10. The size of the individual filament 10 is controlled by the size of the capillary 66, the metering rate and the speed at which the filaments 10 are withdrawn from the quench zone and typically fixed by the rotational speed of the feed roll assembly, and not by capillary design alone. The cross section 12 of the filaments 10 are smaller than the actual size of the capillary 66 through which they are produced.

Figures 8A and 8B illustrate a first double diamond shaped spinneret capillary 866 and a first double diamond shaped cross section 812 of a filament 800 in accordance with this invention formed by spinning polymer through the first double diamond shaped spinneret capillary 866.

Figures 9A and 9B illustrate a second double diamond shaped spinneret capillary 966 and a second double diamond shaped cross section 912 of a filament 900 in accordance with this invention formed by spinning polymer through the second double diamond shaped spinneret capillary 966.

INDUSTRIAL APPLICABILITY

The filaments 10, 800, 900, yarns 44 and fabrics 52 of the present invention have market uses that include automobile airbags, industrial fabrics (architectural

fabrics, signage, tarps, tents, etc.) sailcloth, tire cord, cordage (ropes), webbing, leisure fabrics, mechanical rubber goods, and others.

5

TEST METHODS

Temperature: All temperatures are measured in degrees Celsius (°C).

Relative Viscosity: Any Relative Viscosity (RV) measurement referred to herein is the unitless ratio of the viscosity of a 4.47 weight on weight percent solution of the polymer in hexafluoroisopropanol containing 100 ppm sulfuric acid to the viscosity of the solvent at 25° C. Using this solvent, the industrial yarns in the prior art, such as U.S. Patent 3,216,817, have relative viscosities of at least 35.

Denier: All parts and percentages are by weight unless otherwise indicated.

Denier is linear density and defined to be the number of unit weights of 0.05 gram per 450 meters (Man-Made Fiber and Textile Dictionary, Hoechst-Celanese, 1988). This definition is numerically equivalent to weight in grams per 9000 meters of the material. Another definition of linear density is Tex, the weight in grams of 1000 meters of material. The deciTex (dTex) is also widely used, equal to 1/10 of 1 Tex.

All yarn deniers reported herein are nominal deniers unless otherwise indicated as measured. As used herein, "nominal" denier means the intended numerical value of denier.

As used herein, "measured" denier is by the method of cutting a standard length of yarn and weighing. The industrial polyester yarns, reported herein, had their yarn deniers determined by an E. I. du Pont de Nemours and Company (Wilmington, DE) designed automatic cut and

weigh (ACW) deniering instrument. This ACW instrument is commercially available from LENZING AG, Division Lenzing Technik, A-4860 Lenzing, Austria. Measured denier was by the ACW instrument method and based on 2 observations per yarn package. These two observations were averaged. Thus, the "measured" denier is an average denier. The yarn test specimen length was 22.5 meters and the specimen length tolerance was +/- 1.0 cm. All ACW machine weights were within +/- 0.2 milligram tolerance of certified standards used in machine calibration. The calculations for denier were based on the equation:

$$D = (9000 \text{ meter} \times W(\text{grams}) / 22.5 \text{ meters})$$

where D = denier; and W = specimen weight.

For example, a 22.5 meter length of yarn from a sample of 840 nominal denier yarn was cut and weighed by the ACW machine. This 22.5 meter sample should have a measured weight of 2.10 grams for the nominal and measured yarn denier to be identical at 840 denier (or 933.3 deciTex). Similarly, the 1000 nominal denier yarns (or 1111 dTex) reported herein should have a weight of 2.50 grams for the nominal and measured yarn denier to be identical and the 1100 nominal denier yarns (or 1222 dTex) have a weight of 2.75 grams per 22.5 meters for the nominal and measured yarn denier to be identical.

The "measured" yarn denier has been reported in the prior art in two ways. The first way is "as spun" measured denier which includes yarn finish and ambient moisture. Typically, our "nominal" 840 yarn denier is 847 measured denier "as spun". The second way "measured" yarn denier is reported is "measured" yarn denier "as sold". The term "as sold" does not mean the filaments were, in fact, sold or offered for sale. Instead, it means the yarn is prepared as if it was going to be sold

prior to denier measurement. Prior to "as sold" denier measurement, the yarn finish is scoured off and the yarn standard moisture content is equilibrated at 0.4%. The "as sold" measured yarn denier is, by definition, equal to nominal denier or 840 in this case. All "measured" yarn denier reported herein is "as spun", meaning the weight of yarn finish and ambient moisture is included in the calculation.

10 **Tensile Properties:** The tensile properties for the yarns reported herein are measured on an Instron Tensile Testing Machine (Type TTARB). The Instron extends a specified length of untwisted yarn to its breaking point at a given extension rate. Prior to tensile testing, all 15 yarns are conditioned at 21.1 degrees C. and 65% relative humidity for 24 hours. Yarn "extension" and "breaking load" are automatically recorded on a stress-strain trace. For all yarn tensile tests herein, the sample length was 10 inches (25 cm), the extension rate was 12 20 inches/minute (30 cm) or 120%/minute, and the stress-strain chart speed was 12 inches/minute (30 cm/minute).

Tenacity: Yarn "tenacity" (T) was derived from the yarn breaking load. Tenacity (T) was measured using the 25 Instron Tensile Tester Model 1122 which extends a 10-inch (25 cm) long yarn sample to its breaking point at an extension rate of 12 inch/min (30 cm/min) at a temperature of about 25°C. Extension and breaking load are automatically recorded on a stress-strain trace by 30 the Instron. Tenacity is numerically defined by the breaking load in grams divided by the original yarn sample measured denier.

Dry Heat Shrinkage: Dry Heat Shrinkages (DHS) are 35 determined by exposing a measured length of yarn under zero tension to dry heat for 30 minutes in an oven

maintained at the indicated temperatures (177 degrees C for DHS177 and 140 degrees C for DHS140) and by measuring the change in length. The shrinkages are expressed as percentages of the original length. DHS177 is most frequently measured for industrial yarns, we find DHS140 to give a better indication of the shrinkage that industrial yarns actually undergo during commercial coating operations, although the precise conditions vary according to proprietary processes.

10

EXAMPLES

This invention will now be illustrated by the following specific examples.

15

COMPARATIVE EXAMPLE A

Industrial polyester filaments with round or circular cross sections were produced in accordance with the process disclosed in U.S. Patent 4,622,187 to Palmer. More specifically, and referring to Figure 10, polyester filaments 80 were melt-spun from a spinneret 82, and solidified as they passed down within chimney 83 to become an undrawn multifilament yarn 84, which was advanced to the drawing stage by feed roll 85, the speed of which determined the spinning speed, i.e., the speed at which the solid filaments are withdrawn in the spinning step. The undrawn yarn 84 was advanced past heater 86, to become drawn yarn 87, by draw rolls 88 and 89, which rotated at the same speed, being higher than that of feed roll 85. The draw ratio is the ratio of the speed of draw rolls 88 and 89 to that of feed roll 85, and was generally between 4.7X and 6.4X. The drawn yarn 87 was annealed as it made multiple passes between draw rolls 88 and 89 within heated enclosure 90. The resulting yarn 92 was interlaced to provide coherency as it passed through interlacing jet 94. Interlace jet 94 provided heated air so that the interlaced yarn 95 was

30
35

maintained at an elevated temperature as it was advanced to wind-up roll 96 where it was wound to form a yarn package. The interlaced yarn 95 was relaxed because it was overfed to wind-up roll 96, i.e., the speed of wind-up roll 96 was less than that of rolls 89 and 88. Finish was applied in conventional manner, not shown, generally being applied to undrawn yarn 84 before feed roll 85 and to drawn yarn 87 between heater 86 and heated enclosure 90.

10 The draw roll speed was 3100 ypm (2835 meters/min). The properties were measured as described hereinafter. The process was followed using a steam jet at 360°C for the heater 86, and a draw ratio of 5.9X between draw roll 88 and feed roll 85, heating rolls 88 and 89 to 240°C
15 within enclosure 90, overfeeding the yarn 13.5% between roll 89 and wind-up roll 96, so that the wind-up speed was 2680 ypm (about 2450 meters/min), and using interlacing air at 45 pounds per square inch (psi) and at 160°C in jet 94.

20 A yarn of 840 nominal denier, 140 filaments and 37 relative viscosity was made using the process and apparatus described above. The yarn was made of filaments with round or circular cross-sections. The filaments were spun from polyester polymer (2GT) having
25 0.10% titanium dioxide as a delusterant, residual antimony catalyst at a level in the range of 300 to 400 parts per million, and small amounts of phosphorus in a range of 8 to 10 parts per million. The only other intentionally provided additive was a "toner", which was
30 an anthraquinone dye, at level of 1 to 5 parts per million.

The round cross-section yarn so produced had a good balance of shrinkage and tensile properties. The produced yarn had a measured "as spun" average denier of
35 847. The measured denier range was from 823 to 873. The yarn had a tenacity of 7.9 grams per denier and an

elongation at break equal to 28%. The shrinkage (DHS177) of the yarn was 3.1%. The properties of this Comparative Example A yarn are summarized in Table 1. This Comparative Example shows the properties of a typical
5 prior art Dacron[®] industrial yarn (with round filament cross sections as illustrated in Figure 15B) sold by DuPont under designation 840-140-T51 and is a low shrinkage yarn. This prior art yarn packs together as the filament bundle illustrated by Figure 3.

10

COMPARATIVE EXAMPLE B

Using exactly the same conditions as in Comparative Example A, except for a spinneret was used with an enlarged capillary dimension versus that capillary
15 dimension used in Example 1, yarns of 1000 nominal denier were produced having 140 filaments with round cross sections as shown in Figure 15B. The same shrinkage and tensile properties as for Comparative Example A yarns were measured. The properties of this Comparative
20 Example B yarn are summarized in Table 1. This Comparative Example B shows the properties of a typical prior art Dacron[®] industrial yarn sold by DuPont under designation 1000-140-T51, a low shrinkage yarn.

25

COMPARATIVE EXAMPLE C

Using exactly the same conditions as in Comparative Example A, except as note herein, yarns of 1000 nominal denier were produced having 192 filaments with round
30 cross sections as shown in Figure 15B. As in Comparative Example B, spinneret was used with an enlarged capillary dimension versus that capillary dimension used in Comparative Example A. The shrinkage and tensile properties were different from those properties of Comparative Example A yarns by means of altered process
35 conditions: the overfeed speed between roll 9 and wind-up roll 14 was reduced to 5%, so that the wind-up roll

speed was 2945 yards per minute (2693 meters/min.) and the interlace air temperature was at room temperature (ca. 30 degrees C.) and slightly higher delivery pressure, 50 pounds per square inch. These yarns had a
5 tenacity of 8.9 grams per denier, an elongation at break of 17.5% and a dry heat shrinkage (DHS177) of 12.2%. The properties of this Comparative Example B yarn are summarized in Table 1. This Comparative Example B shows the properties of a typical prior art Dacron® industrial
10 yarn sold by DuPont under designation 1000-192-T68, a high shrinkage yarn.

COMPARATIVE EXAMPLE D

Using exactly the same conditions as in Comparative
15 Example C, except as noted herein, yarns of 1000 nominal denier and 192 filaments were produced from spinnerets with capillary shapes as shown in Figure 11A. The resulting filaments had "S"-shaped cross sections as shown in Figure 11B. These yarns had dry-heat shrinkage
20 properties which measured the same as in Comparative Example C. The properties of this Comparative Example D yarn are summarized in Table 1.

COMPARATIVE EXAMPLE E

25 Using exactly the same conditions as in Comparative Example A, except as noted herein, yarns of 1100 nominal denier were produced having 140 filaments. The filaments were produced from spinnerets with capillary shapes as shown in Figure 14A and resulted in filaments with flat
30 ribbon shaped cross sections as shown in Figure 14B. These yarns had dry-heat shrinkage properties which measured the same as in Comparative Example A. The properties of this Comparative Example E yarn are summarized in Table 1.

35

COMPARATIVE EXAMPLE F

Using exactly the same conditions as in Comparative Example E, except as noted herein, yarns of 1000 nominal denier were produced having 140 filaments from spinnerets with capillary shapes as shown in Figure 14A. These yarns had filaments with flat ribbon shaped cross sections as shown in Figure 14B. These yarns had dry-heat shrinkages which were produced according to the method disclosed in Palmer, U.S. Patent 4,622,187, Example 1, Sample A, where an overfeed between roll 9 and wind-up 14 of 9.1% allowed a wind-up speed of 2820 yards per minute (2580 meters/min.) and interlace air at 50 pounds per square inch delivery pressure and about 30 degrees C. provided a dry-heat shrinkage (DHS177) of 5.3% and a tenacity of 8.4 grams per denier. The properties of this Comparative Example F yarn are summarized in Table 1.

COMPARATIVE EXAMPLE G

Using exactly the same conditions as in Comparative Example F, except as noted herein, yarns of 1000 nominal denier were produced having 140 filaments from spinnerets with capillary shapes as shown in Figure 12A. This yarn had filaments with hollow bilobal shaped cross sections as shown in Figure 12B. The properties of this Comparative Example G yarn are summarized in Table 1.

COMPARATIVE EXAMPLE H

Using exactly the same conditions as in Comparative Example A, except as noted herein, yarns of 1000 nominal denier were produced having 140 filaments from spinnerets with enlarged capillary shapes as shown in Figure 13A. This yarn had filaments with hollow disc shaped cross sections as shown in Figure 13B. The properties of this Comparative Example H yarn are summarized in Table 1.

COMPARATIVE EXAMPLE I

Using exactly the same conditions as in Comparative Example A, except as noted herein, yarns of 1000 nominal denier were produced having 140 filaments from spinnerets with enlarged capillary shapes as shown in Figure 11A. This yarn had filaments with "S"-shaped cross sections as shown in Figure 11B. The properties of this Comparative Example I yarn are summarized in Table 1.

COMPARATIVE EXAMPLE J

Using exactly the same conditions as in Comparative Example A, except as noted herein, yarns of 840 nominal denier were produced having 140 filaments from spinnerets with capillary shapes as shown in Figure 11A. This yarn had filaments with "S"-shaped cross sections as shown in Figure 11B. The properties of this Comparative Example J yarn are summarized in Table 1.

COMPARATIVE EXAMPLE K

Using exactly the same conditions as in Comparative Example C, except as noted herein, a yarn of 840 nominal denier was produced having 140 filaments. The filaments were produced from spinnerets with round capillary shapes as shown in Figure 15A and resulted in filaments with round shaped cross sections as shown in Figure 15B. The properties of this Comparative Example K yarn are summarized in Table 1. This Comparative Example shows the properties of a typical prior art Dacron[®] industrial yarn sold by DuPont under designation 840-140-T68, a high shrinkage yarn.

COMPARATIVE EXAMPLE L

Using exactly the same conditions as in Comparative Example A, except a spinneret was used with an enlarged capillary versus the capillaries used in Comparative Example A yarns of 1100 nominal denier were produced

having 140 filaments with round cross sections as shown in Figure 15B. The same shrinkage properties as for Comparative Example A yarns were measured. The properties of this Comparative Example L yarn are
5 summarized in Table 1. This Comparative Example shows the properties of a typical prior art Dacron® industrial yarn sold by DuPont under designation 1100-140-T51, a low shrinkage yarn.

10

EXAMPLE 1

Using exactly the same conditions as in Comparative Example A, except for a spinneret with a capillary was used as shown in Figures 6 and 7 and the interlace air was turned off, a yarn of 840 nominal denier and 140
15 filaments was produced. This yarn had filaments with elongated diamond cross section. A cross section of the yarn is schematically reproduced in Figure 4 from a photomicrograph. The produced yarn had a measured "as spun" average denier of 848. The yarn tenacity was 7.5
20 grams per denier, breaking strength was 14.7 grams, elongation at break was 26.9 percent, DHS177 was 2.7 and interlace was 2.7 nodes per meter. The filaments had an average aspect ratio of 3.9 determined by measurement of 7 randomly selected filaments in one photomicrograph view
25 of the cross section of the yarn bundle. The properties of this Example 1 yarn illustrating the invention are summarized in Table 1. This Example shows that the properties of a yarn made from filaments with elongated cross sections have industrial properties similar to
30 those of the Comparative Examples A and J yarns. This Example additionally shows by comparison of Figure 4 with Figure 3, that the Example 1 filaments have a closer or more dense packing with less open space between adjacent filaments.

35

EXAMPLE 2

Except for a spinneret with an enlarged capillary dimension, exactly the same conditions to prepare the yarns as in Example 1 were used. Yarns of 1000 nominal
5 denier and 140 filaments having filaments with the Figure 1. cross section elongated diamond shape were produced. These yarns have a measured "as spun" average denier of 1009. Tenacity, interlace and shrinkage are the same as in Example 1. These Example 2 yarns exhibited properties
10 similar to those of Example 1 yarns and had an aspect ratio of 4 based on measurements of randomly selected filaments. This elongated diamond cross section filament yarn is a low shrinkage yarn. The properties of this Example 2 yarn illustrating the invention are summarized
15 in Table 1. This Example 2 shows that the properties of the Example 2 yarn made from filaments with elongated cross sections have industrial properties similar to those of the Comparative Example B and I yarns.

20

EXAMPLE 3

Using exactly the same conditions as in Comparative Example C, except as noted herein, yarns of 1000 nominal denier and 192 filaments of the Figure 1 cross sectional shape were produced. The measured "as spun" average
25 denier for these yarn packages was 1008. Dry-heat shrinkage (DHS177) and tensile properties measured the same as in Comparative Example C, 12.2%. This elongated cross section filament yarn is a high shrinkage yarn. The properties of this Example 3 yarn illustrating the
30 invention are summarized in Table 1. This Example 3 shows that the properties of the Example 3 yarn made from filaments with elongated cross sections have industrial properties similar to those of the Comparative Example C and D yarns.

TABLE 1. YARNS

	<u>Comparative Examples</u>	<u>Nominal Yarn Den.</u>	<u>Meas.</u>					<u>shrink. %</u>	<u>aspect ratio</u>
			<u>No. Fil.</u>	<u>Yarn Den.</u>	<u>Den/ Fil.</u>	<u>(g/Den) Ten.</u>			
5	A(Fig. 15B)	840	140	848	6.0	7.9	3.1	1	
	B(Fig. 15B)	1000	140	1009	7.1	7.9	3.1	1	
	C(Fig. 15B)	1000	192	1008	5.2	8.9	12.2	1	
	D(Fig. 11B)	1000	192	1008	5.2	8.9	12.2	3	
	E(Fig. 14B)	1100	140	1110	7.9	7.9	3.1	7	
10	F(Fig. 14B)	1000	140	1007	7.1	8.4	5.3	7	
	G(Fig. 12B)	1000	140	1007	7.1	8.4	5.3	2.1	
	H(Fig. 13B)	1100	140	1110	7.9	7.8	3.1	1.6	
	I(Fig. 11B)	1000	140	1009	7.1	7.5	2.7	3	
	J(Fig. 11B)	840	140	847	7.1	7.5	2.7	3	
15	K(Fig. 15B)	840	140	847	6.0	8.9	12.2	1	
	L(Fig. 15B)	1100	140	1110	7.9	7.9	3.1	1	

**Invention
Examples**

20	1(Fig. 1)	840	140	848	6.0	7.5	2.7	3.9
	2(Fig. 1)	1000	140	1009	7.1	7.5	2.7	4
	3(Fig. 1)	1000	192	1008	5.2	8.9	12.2	4

Table 1 summarizes the properties of Comparative Example yarns A through L with the invention Example yarns 1, 2 and 3. The invention yarn properties, particularly those properties consistent with industrial yarn applicability, e.g., tenacity and shrinkage, are shown by way of this Table 1 comparison to be substantially preserved regardless of filament cross sectional shape. The elongated diamond cross-section shaped filaments in the form of industrial polyester yarns are not different or substantially different from the prior art and other comparison yarns with respect to these properties. The surprising and distinguishing features of the inventive yarns are found in the properties of a fabric incorporating yarns with at least

some of the elongated diamond cross section shaped filaments.

EXAMPLE 4

5 A fabric was constructed from the Comparative Example K yarns in the warp direction with 19.5 yarns or picks per inch (ppi) and Example 3 yarns in the fill direction with 21 ppi. The fabric was visually rated for cover creating ability of the fill yarn by an observer
10 using a light box for background illumination of the fabric. A 1-10 rating system was used with a rating of 1 given to the control fabric (Comparative Example S) and higher numbers given to indicate visually better covering power. Properties for and observations on this fabric
15 are summarized in Table 2.

COMPARATIVE EXAMPLE M

A fabric was constructed from the Comparative Example K yarns in the warp direction with 19.5 yarns or
20 picks per inch (ppi) and Comparative Example D yarns in the fill direction with 21 ppi. The fabric was visually rated for cover creating ability of the fill yarn by an observer using a light box for background illumination of the fabric. A 1-10 rating system was used with a rating
25 of 1 given to the control fabric (Comparative Example S) and higher numbers given to indicate visually better covering power. Properties for and observations on this fabric are summarized in Table 2.

COMPARATIVE EXAMPLE N

30 A fabric was constructed from the Comparative Example K yarns in the warp direction with 19.5 ppi and Comparative Example E yarns in the fill direction with 21 ppi. The fabric was visually rated for cover creating
35 ability of the fill yarn by an observer using a light box for background illumination of the fabric. A 1-10 rating

system was used with a rating of 1 given to the control fabric (Comparative Example S) and higher numbers given to indicate visually better covering power. The resulting fabric was visually rated for cover power.

5 Properties for and observations on this fabric are summarized in Table 2.

COMPARATIVE EXAMPLE O

A fabric was constructed from the Comparative
10 Example K yarns in the warp direction with 19.5 ppi and Comparative Example F yarns in the fill direction with 21 ppi. The fabric was visually rated for cover creating ability of the fill yarn by an observer using a light box for background illumination of the fabric. A 1-10 rating
15 system was used with a rating of 1 given to the control fabric (Comparative Example S) and higher numbers given to indicate visually better covering power. The resulting fabric was visually rated for cover power. Properties for and observations on this fabric are
20 summarized in Table 2.

COMPARATIVE EXAMPLE P

A fabric was constructed from the Comparative
25 Example K yarns in the warp direction with 19.5 ppi and Comparative Example G yarns in the fill direction with 21 ppi. The fabric was visually rated for cover creating ability of the fill yarn by an observer using a light box for background illumination of the fabric. A 1-10 rating
30 system was used with a rating of 1 given to the control fabric (Comparative Example S) and higher numbers given to indicate visually better covering power. The resulting fabric was visually rated for cover power. Properties for and observations on this fabric are
summarized in Table 2.

35

COMPARATIVE EXAMPLE Q

A fabric was constructed from the Comparative Example K yarns in the warp direction with 19.5 ppi and Comparative Example H yarns in the fill direction with 21 ppi. The fabric was visually rated for cover creating ability of the fill yarn by an observer using a light box for background illumination of the fabric. A 1-10 rating system was used with a rating of 1 given to the control fabric (Comparative Example S) and higher numbers given to indicate visually better covering power. The resulting fabric was visually rated for cover power. Properties for and observations on this fabric are summarized in Table 2.

COMPARATIVE EXAMPLE R

A fabric was constructed from the Comparative Example K yarns in the warp direction with 19.5 ppi and Comparative Example 1 yarns in the fill direction with 21 ppi. The fabric was visually rated for cover creating ability of the fill yarn by an observer using a light box for background illumination of the fabric. A 1-10 rating system was used with a rating of 1 given to the control fabric (Comparative Example S) and higher numbers given to indicate visually better covering power. The resulting fabric was visually rated for cover power. Properties for and observations on this fabric are summarized in Table 2.

COMPARATIVE EXAMPLE S

A fabric was constructed from the Comparative Example K yarns in the warp direction with 19.5 ppi and Comparative Example A yarns in the fill direction with 21 ppi. The fabric was visually rated for cover creating ability of the fill yarn by an observer using a light box for background illumination of the fabric. A 1-10 rating system was used with a rating of 1 given to the control

fabric (Comparative Example S) and higher numbers given to indicate visually better covering power. The resulting fabric was visually rated for cover power. Properties for and observations on this fabric are summarized in Tables 2 and 3.

TABLE 2. FABRICS AND COVER RATINGS
FOR: (19.5 warp yarns/inch) X (21 fill yarns/inch)
FABRIC CONSTRUCTION

Example (warp X fill)	cover rating	comment
4 K X 3	10	Highest cover ability. Overfills construction. Uniform appearance. No voids in fabric.
M K X D	9.5	Higher cover ability than Ex. O. Overfills construction in a way not seen in Ex. N. Uniform appearance. No voids in fabric.
25 N K X E	9.5	Higher cover ability than Ex. O. Fills construction with fill inferior to Ex. 4. Uniform appearance. No voids in fabric.
O K X F	7	Higher cover ability than Ex. P. Fills fabric construction with fill inferior to Ex. 4. Uniformity slightly inferior to Ex. N. No voids in fabric.
40 P K X G	5	Higher cover ability than Ex. Q. Fills fabric construction with fill inferior to Ex. 4. Some slight voids in construction.

TABLE 2. FABRICS AND COVER RATINGS (continued)
FOR: (19.5 warp yarns/inch) X (21 fill yarns/inch)
FABRIC CONSTRUCTION

5	Example (warp X fill)	cover rating	comment
10	Q K X H	3	Just slightly better cover than Ex. R. Some voids noted in construction and some non-uniformity.
15	R K X L	2	Just slightly better cover than "control" with voids in fabric.
20	S K X A(control)	1	Well-distributed voids in construction of fabric.

Table 2 summarizes the cover properties of 8 signage fabrics constructed with Comparative Example K yarns in the warp of the fabric (19.5 warp yarns per inch) and a variety of fill yarns, including the invention, at 21 fill yarns per inch. Example S was the control fabric. The control fabric, Example S (= K X A) was visually rated for fabric cover and assigned a rating of 1. The control was described by comments appropriate to this subjective cover rating of 1 versus the other examples. The control fabric showed open fabric voids which were well-distributed throughout the fabric. The distribution of voids or spaces between yarns comprising the fabric allowed some light transmission when viewed against a light box, but appearance was otherwise uniform.

EXAMPLE 5

A fabric was constructed from the Comparative Example K yarns in the warp direction with 19.5 picks per inch (ppi) and Example 1 yarns in the fill direction with 17.8 ppi. Comments comparing the cover power of this fabric to other fabrics are provided in Table 3. Further, the % weight reduction of this fabric versus the

weight of Comparative Example S (control) fabric was calculated and is presented in Table 4.

EXAMPLE 6

5 A fabric was constructed from the Comparative
Example K yarns in the warp direction with 19.5 picks per
inch (ppi) and the Example 2 yarns in the fill direction
with 15.8 picks per inch (ppi). Comments comparing the
cover power of this fabric to other fabrics are provided
10 in Table 3.

COMPARATIVE EXAMPLE T

 A fabric was constructed from the Comparative
Example K yarns in the warp direction with 19.5 ppi and
15 the Comparative Example J yarns in the fill direction
with 17.8 ppi. Comments comparing the cover power of
this fabric to other fabrics are provided in Table 3.

COMPARATIVE EXAMPLE U

20 A fabric was constructed from the Comparative
Example K yarns in the warp direction with 19.5 ppi and
the Comparative Example I yarns in the fill direction
with 15.8 ppi. Comments comparing the cover power of
this fabric to other fabrics are provided in Table 3.

25

TABLE 3. FABRICS AND COVER RATINGS

Control = S = K X A,
(19.5 warp yarns/inch) X (21 fill yarns/inch)

5 Invention = K in warp, (19.5 warp yarns/inch) X
(indicated fill yarns/inch)

	Example	fabric construction (warp X fill)	fill yarns/ inch	comments
10	5	K X 1	17.8	Slightly better cover than control. Smooth uniform appearance with no fabric voids.
15				
20	6	K X 2	15.8	Slightly better cover than control despite reduced fill yarn in fabric. Smooth uniform appearance with no fabric voids.
25				
30	T	K X J	17.8	Slightly better cover than control. Smooth uniform appearance with no fabric voids.
35				
40	U	K X I	15.8	Slightly better cover than control. Smooth uniform appearance with no fabric voids.
45				
	S	K X A(Control)	21.0	Uniform cover with well distributed fabric voids.

In Table 3, the cover and appearance performance of 4 fabrics, Examples 5 and 6 and Comparative Examples T and U, versus the control fabric Example S are summarized. Examples 5 and 6 show that an entirely

commercially satisfactory fabric cover and appearance are obtained from the elongated diamond cross section filament yarns, even when present at a reduced fill-yarn count, versus round cross section filament yarns of denser weave. This result is surprising in view of the generally accepted strategy of using dense weaves to obtain more cover. Denser weaves are, however, produced at some additional expense. More fill yarns present in a weave slow the weaving process since the weaving machine requires more time to introduce the fill yarns. This result of Examples 5 and 6 demonstrated a faster weaving process is obtainable since the fill yarn count is reducible at a constant appearance property for the fabric. Furthermore, this reduced fill yarn count translates into a fabric weight savings versus higher fill counts.

EXAMPLE 7

A fabric is constructed from the Example 2 yarns in the warp direction with 15.8 ppi and the Example 1 yarns in the fill direction with 15.8 ppi. The % weight reduction of this fabric versus the weight of Comparative Example S (control) fabric was calculated and is presented in Table 4.

25

TABLE 4. FABRIC WEIGHT REDUCTION

<u>S = Control</u>	<u>warp yarns</u>	<u>fill yarns</u>	<u>% weight reduction</u>
<u>Example</u>	<u>per inch</u>	<u>per inch</u>	<u>vs. control (S)</u>
S (= K X A)	19.5	21	n/a
T (= K X J)	19.5	17.8	13.6
U (= K X I)	19.5	15.8	7.9
5 (= K X 1)	19.5	17.8	13.6
6 (= K X 2)	19.5	15.8	7.9
7 (= 2 X 1)	15.8	15.8	>17

40

Those skilled in the art, having the benefit of the teachings of the present invention as hereinabove set forth, can effect numerous modifications thereto. These
5 modifications are to be construed as being encompassed within the scope of the present invention as set forth in the appended claims.

CLAIMS

What is claimed is:

1. An industrial filament, comprising:
5 a synthetic melt spun polymer having a relative
viscosity about 24 to about 42, a denier of about 4 to
about 8, a tenacity of about 6.5 grams/denier to about
9.2 grams/denier, and an elongated diamond shaped cross
10 section normal to a longitudinal axis of the filament,
the cross section having an aspect ratio of about 2 to
about 6.
2. The industrial filament of Claim 1, wherein the
aspect ratio is about 3.5 to about 4.5.
15
3. The industrial filament of Claim 1, wherein the
aspect ratio (AR) is defined as a ratio of a first
dimension (A) to a second dimension (B) where the first
dimension (A) is defined as a length of a straight line
20 segment connecting first and second points in the
periphery of the filament cross section that are farthest
from one another and the second dimension B is a maximum
width of the cross section extending at right angles to
the straight line segment.
25
4. The industrial filament of Claim 1, wherein the
polymer consists essentially of poly(ethylene
terephthalate).
- 30 5. The industrial filament of Claim 1, wherein the
denier is about 6 grams to about 7.2 grams.
6. The industrial filament of Claim 1, wherein the
tenacity is about 7.5 grams/denier to about 8.0
35 grams/denier.

7. The industrial filament of Claim 1, comprising a dry heat shrinkage of about 2% to about 16% at 30 minutes at 177°C.

5 8. An industrial yarn, comprising:

a plurality of industrial filaments, each of the filaments comprising:

10 a synthetic melt spun polymer having a relative viscosity about 24 to about 42, a denier of about 4 to about 8, a tenacity of about 6.5 grams/denier to about 9.2 grams/denier, and an elongated diamond shaped cross section normal to a longitudinal axis of the filament, the cross section having an aspect ratio of about 2 to about 6.

15

9. The industrial yarn of Claim 8, wherein the filaments are positioned in a tile arrangement such that oblique ends of the cross sections in a first row of the filaments are near acute ends of the cross sections of filaments in rows of the filaments on both sides of the first row.

10. An industrial fabric, comprising:

25 a plurality of first industrial yarns in a warp direction;

a plurality of second industrial yarns in a fill direction weaved with the first industrial yarns; and

30 at least some of the first industrial yarns and/or at least some of the second industrial yarns comprising a plurality of industrial filaments, each of the filaments comprising:

35 a synthetic melt spun polymer having a relative viscosity about 24 to about 42, a denier of about 4 to about 8, a tenacity of about 6.5 grams/denier to about 9.2 grams/denier, and an elongated diamond shaped cross section normal to a longitudinal axis of the filament,

the cross section having an aspect ratio of about 2 to about 6.

11. The industrial fabric of Claim 10, wherein
5 at least the first industrial yarns or the second industrial yarns comprise a plurality of the industrial filaments,

whereby the fabric has a reduction in total weight by at least 7% compared to a fabric made entirely from
10 yarns comprising other filaments which are essentially the same as the industrial filaments, except the other filaments having circular cross sections.

12. The industrial filament of Claim 10, wherein
15 the first industrial yarns and the second industrial yarns comprise a plurality of the industrial filaments, whereby the fabric has a reduction in total weight by at least 13% compared to a fabric entirely made from
20 yarns comprising other filaments which are essentially the same as the industrial filaments, except the other filaments having circular cross sections.

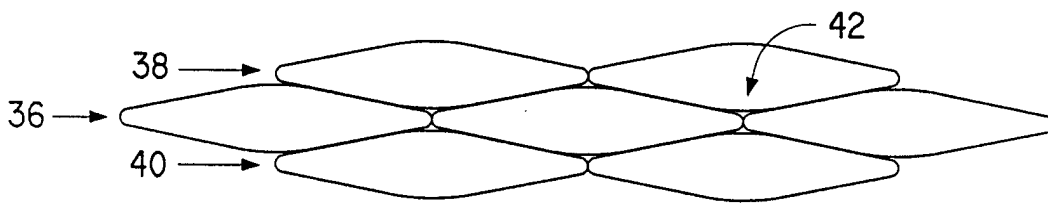
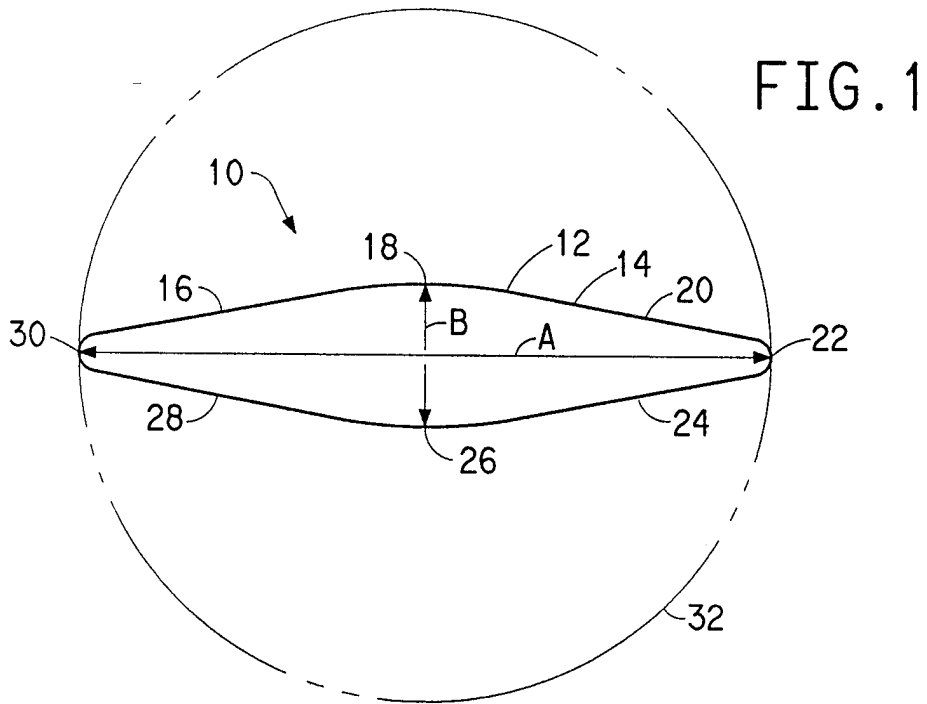

FIG. 2

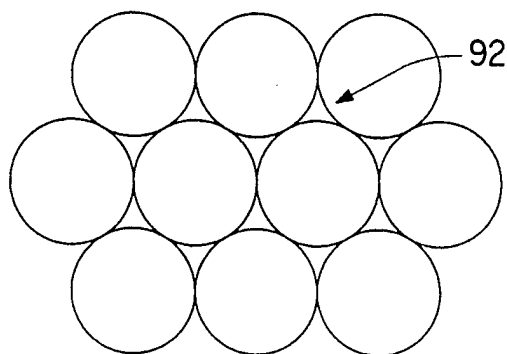

FIG. 3
(PRIOR ART)

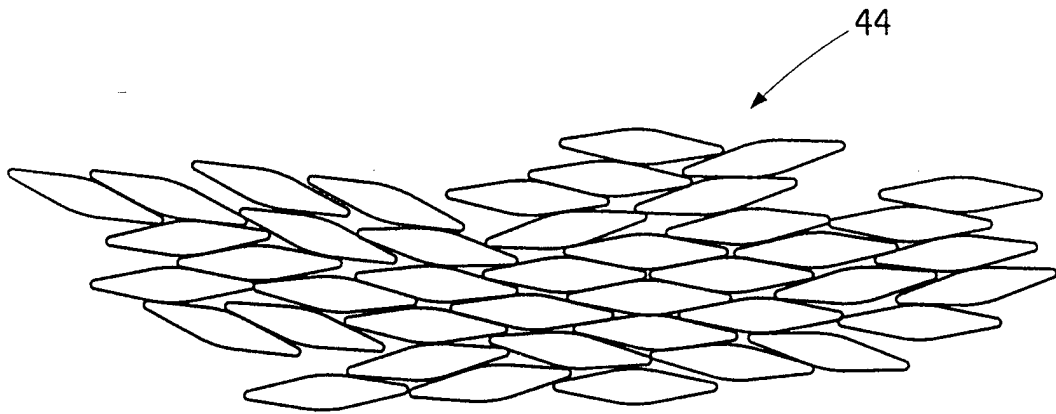

FIG. 4

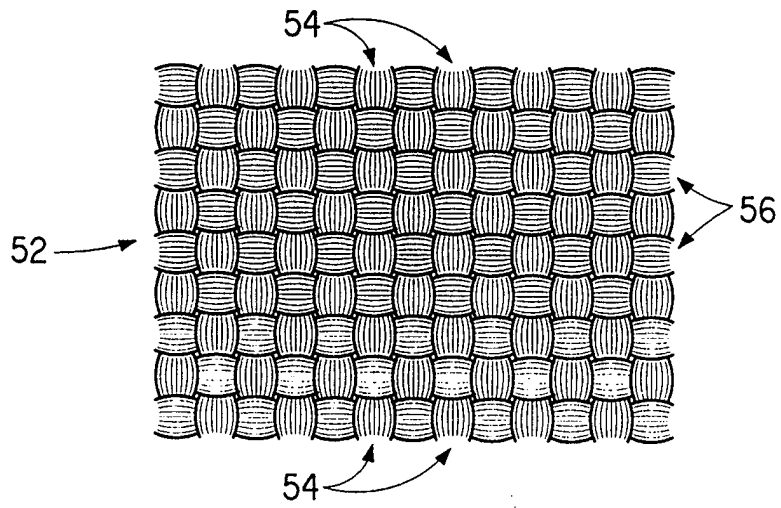

FIG. 5

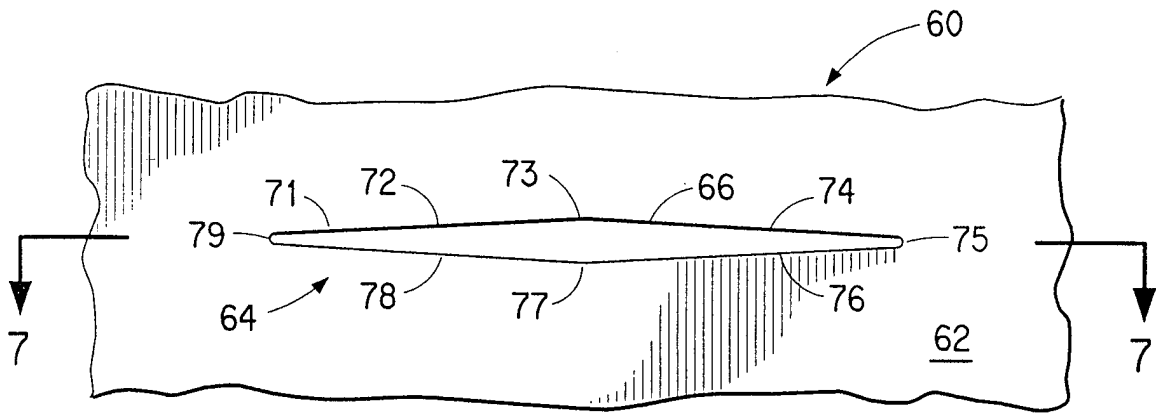

FIG. 6

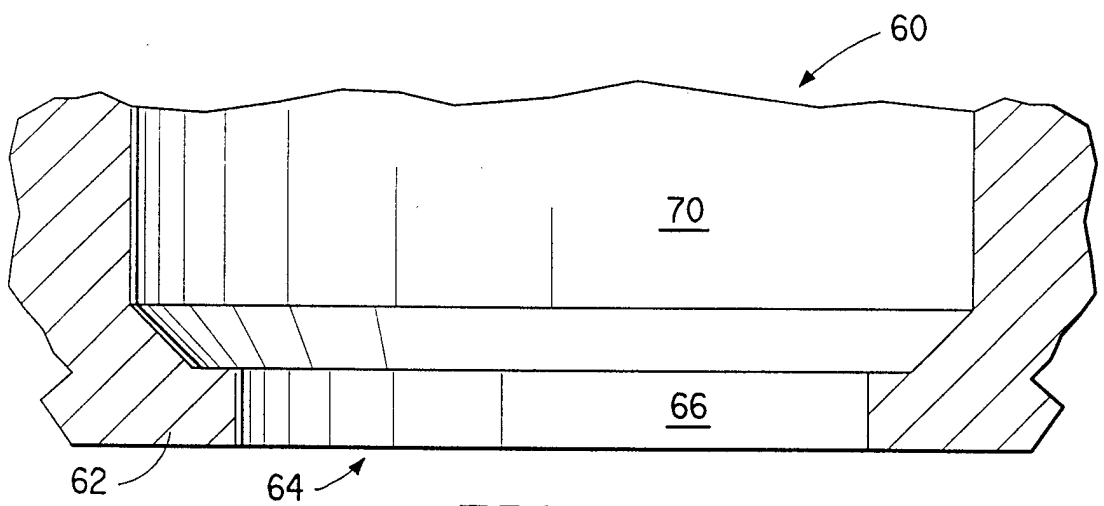

FIG. 7

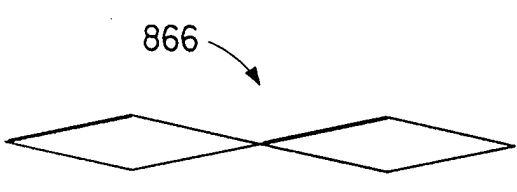

FIG. 8A

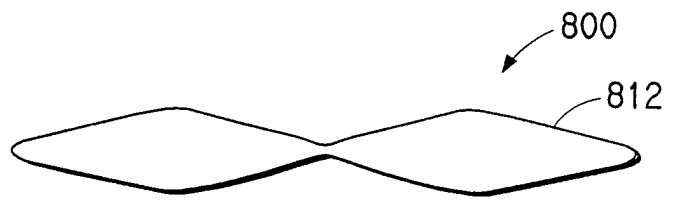

FIG. 8B

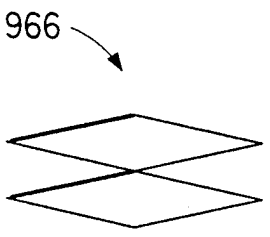

FIG. 9A

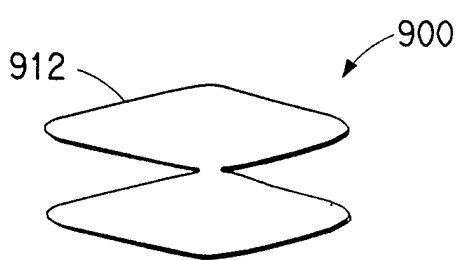

FIG. 9B

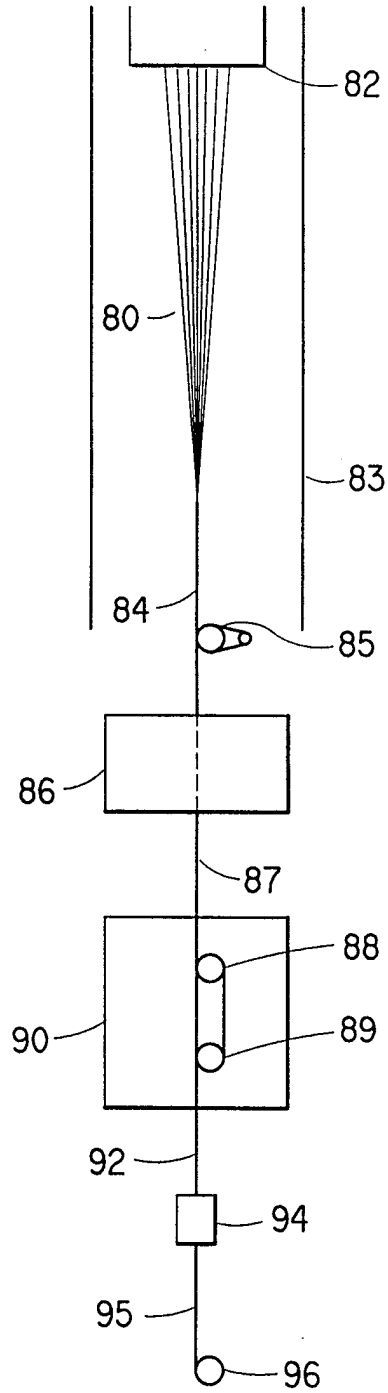

FIG. 10

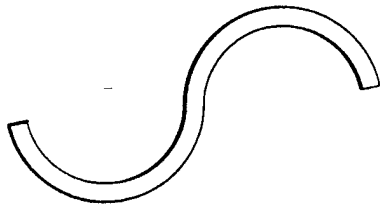

FIG. 11A

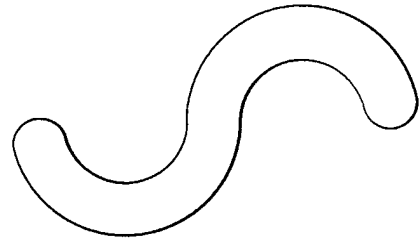

FIG. 11B

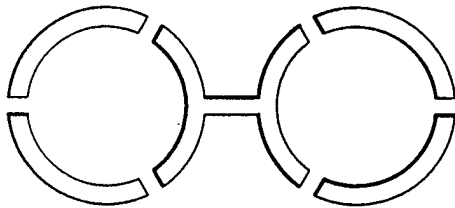

FIG. 12A

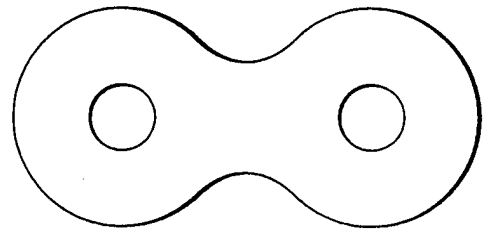

FIG. 12B

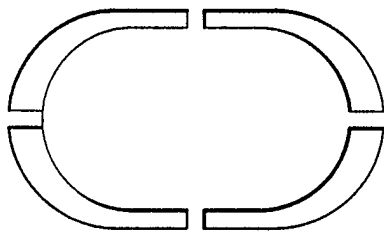

FIG. 13A

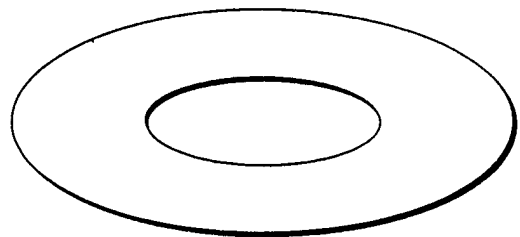

FIG. 13B



FIG. 14A



FIG. 14B

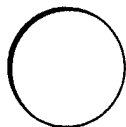

FIG. 15A
(PRIOR ART)

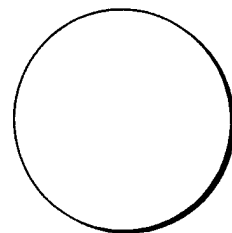

FIG. 15B
(PRIOR ART)

INTERNATIONAL SEARCH REPORT

International Application No

PCT/US 98/03646

A. CLASSIFICATION OF SUBJECT MATTER
 IPC 6 D01D5/253 D01F6/62

According to International Patent Classification (IPC) or to both national classification and IPC

B. FIELDS SEARCHED

Minimum documentation searched (classification system followed by classification symbols)

IPC 6 D01D D01F

Documentation searched other than minimum documentation to the extent that such documents are included in the fields searched

Electronic data base consulted during the international search (name of data base and, where practical, search terms used)

C. DOCUMENTS CONSIDERED TO BE RELEVANT

Category °	Citation of document, with indication, where appropriate, of the relevant passages	Relevant to claim No.
Y	EP 0 364 979 A (HERCULES INC) 25 April 1990 see page 2, line 22 - line 32; claims; example 3 ---	1-12
Y	GB 1 086 873 A (IMPERIAL CHEMICAL INDUSTRIES LIMITED) 11 October 1967 see page 2, line 72 - line 75; claims 1-3,9-11 ---	1-12
Y	US 4 622 187 A (PALMER RUSSELL N) 11 November 1986 cited in the application see the whole document ---	1-12
A	GB 2 007 275 A (BAYER AG) 16 May 1979 see claim 6; figure 4 ---	1-12
	-/--	

Further documents are listed in the continuation of box C.

Patent family members are listed in annex.

° Special categories of cited documents :

- "A" document defining the general state of the art which is not considered to be of particular relevance
- "E" earlier document but published on or after the international filing date
- "L" document which may throw doubts on priority claim(s) or which is cited to establish the publication date of another citation or other special reason (as specified)
- "O" document referring to an oral disclosure, use, exhibition or other means
- "P" document published prior to the international filing date but later than the priority date claimed

- "T" later document published after the international filing date or priority date and not in conflict with the application but cited to understand the principle or theory underlying the invention
- "X" document of particular relevance; the claimed invention cannot be considered novel or cannot be considered to involve an inventive step when the document is taken alone
- "Y" document of particular relevance; the claimed invention cannot be considered to involve an inventive step when the document is combined with one or more other such documents, such combination being obvious to a person skilled in the art.
- "&" document member of the same patent family

Date of the actual completion of the international search

8 June 1998

Date of mailing of the international search report

22/06/1998

Name and mailing address of the ISA

European Patent Office, P.B. 5818 Patentlaan 2
 NL - 2280 HV Rijswijk
 Tel. (+31-70) 340-2040, Tx. 31 651 epo nl,
 Fax: (+31-70) 340-3016

Authorized officer

Tarrida Torrell, J

INTERNATIONAL SEARCH REPORT

Interr. Application No

PCT/US 98/03646

C.(Continuation) DOCUMENTS CONSIDERED TO BE RELEVANT		
Category *	Citation of document, with indication, where appropriate, of the relevant passages	Relevant to claim No.
A	US 4 290 209 A (BUCHANAN JOHN G ET AL) 22 September 1981 see claim 8; figure 6 ---	1-12
A	PATENT ABSTRACTS OF JAPAN vol. 095, no. 003, 28 April 1995 & JP 06 346316 A (MITSUBISHI RAYON CO LTD), 20 December 1994, see abstract; figure -----	1-12

INTERNATIONAL SEARCH REPORT

Inter. Patent Application No

PCT/US 98/03646

Patent document cited in search report	Publication date	Patent family member(s)	Publication date
EP 0364979 A	25-04-1990	US 4868031 A CA 1280580 A DE 68914387 D DE 68914387 T DK 520589 A JP 2182959 A	19-09-1989 26-02-1991 11-05-1994 20-10-1994 22-04-1990 17-07-1990
GB 1086873 A		NONE	
US 4622187 A	11-11-1986	BR 8502404 A CA 1234663 A DE 3562147 A EP 0164624 A IN 162407 A MX 165230 B SU 1438618 A	21-01-1986 05-04-1988 19-05-1988 18-12-1985 21-05-1988 30-10-1992 15-11-1988
GB 2007275 A	16-05-1979	FR 2404060 A JP 54055647 A	20-04-1979 02-05-1979
US 4290209 A	22-09-1981	AU 526925 B AU 4099078 A CA 1092005 A CH 629268 A DE 2847327 A FI 783268 A, B, FR 2407291 A GB 2006843 A, B JP 1193521 C JP 54077704 A JP 58028398 B NL 7810681 A, B, NL 8801313 A, C SE 430082 B SE 7811154 A	10-02-1983 01-05-1980 23-12-1980 15-04-1982 13-12-1979 29-04-1979 25-05-1979 10-05-1979 12-03-1984 21-06-1979 15-06-1983 02-05-1979 01-09-1988 17-10-1983 29-04-1979