



- (51) International Patent Classification:
H04B 3/00 (2006.01)
- (21) International Application Number:
PCT/EP2012/055814
- (22) International Filing Date:
30 March 2012 (30.03.2012)
- (25) Filing Language: English
- (26) Publication Language: English
- (71) Applicant (for all designated States except US): **NOKIA SIEMENS NETWORKS OY** [FI/FI]; Karaportti 3, FI-02610 Espoo (FI).
- (72) Inventor; and
- (75) Inventor/Applicant (for US only): **WARKEN, Markus** [DE/DE]; Pappelweg 2, 88471 Laupheim (DE).
- (81) Designated States (unless otherwise indicated, for every kind of national protection available): AE, AG, AL, AM, AO, AT, AU, AZ, BA, BB, BG, BH, BR, BW, BY, BZ, CA, CH, CL, CN, CO, CR, CU, CZ, DE, DK, DM, DO,

DZ, EC, EE, EG, ES, FI, GB, GD, GE, GH, GM, GT, HN, HR, HU, ID, IL, IN, IS, JP, KE, KG, KM, KN, KP, KR, KZ, LA, LC, LK, LR, LS, LT, LU, LY, MA, MD, ME, MG, MK, MN, MW, MX, MY, MZ, NA, NG, NI, NO, NZ, OM, PE, PG, PH, PL, PT, QA, RO, RS, RU, RW, SC, SD, SE, SG, SK, SL, SM, ST, SV, SY, TH, TJ, TM, TN, TR, TT, TZ, UA, UG, US, UZ, VC, VN, ZA, ZM, ZW.

(84) Designated States (unless otherwise indicated, for every kind of regional protection available): ARIPO (BW, GH, GM, KE, LR, LS, MW, MZ, NA, RW, SD, SL, SZ, TZ, UG, ZM, ZW), Eurasian (AM, AZ, BY, KG, KZ, MD, RU, TJ, TM), European (AL, AT, BE, BG, CH, CY, CZ, DE, DK, EE, ES, FI, FR, GB, GR, HR, HU, IE, IS, IT, LT, LU, LV, MC, MK, MT, NL, NO, PL, PT, RO, RS, SE, SI, SK, SM, TR), OAPI (BF, BJ, CF, CG, CI, CM, GA, GN, GQ, GW, ML, MR, NE, SN, TD, TG).

Published:
— with international search report (Art. 21(3))

(54) Title: TRANSMISSION SYSTEM

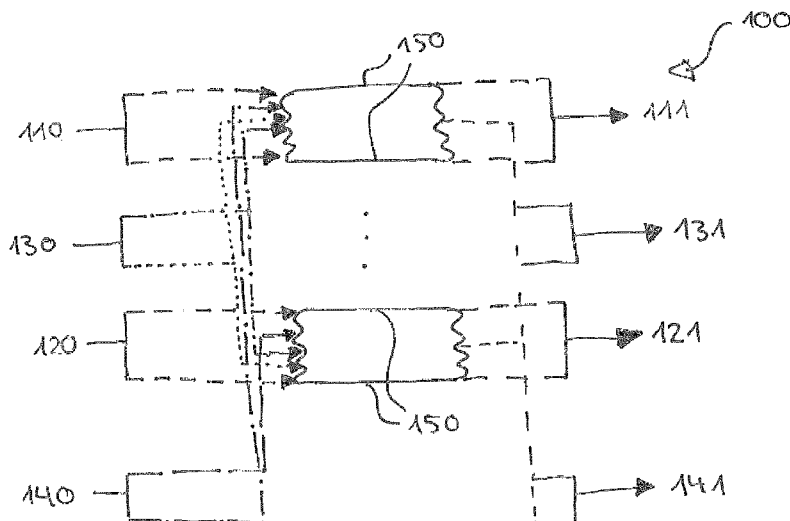

Fig. 1

(57) Abstract: It is described a transmission system (100), in particular for a digital subscriber line transmission. The transmission system comprises a first plurality of input terminals (110, 120), a first plurality of output terminals (111, 121), a plurality of conductor pairs (150), each conductor pair being assigned to one of the first plurality of input terminals (110, 120) and to one of the first plurality of output terminals (111, 121), wherein each conductor pair is formed by a first conductor and a corresponding second conductor, a second plurality of input terminals (130, 140), and a second plurality of output terminals (131, 141). Each conductor pair (150) is adapted to transmit signals to an assigned one of the first plurality of output terminals (111, 121) and to at least two of the second plurality of output terminals (131, 141). The number of input terminals of the first plurality of input terminals (110, 120) corresponds to the number of input terminals of the second plurality of input terminals (130, 140), to the number of output terminals of the first plurality of output terminals (111, 121) and to the number of output terminals of the second plurality of output

terminals (131, 141).

WO 2013/143604 A1

DESCRIPTION

Transmission system

5

Field of invention

The present invention relates to the field of transmission systems, especially to a transmission system for digital
10 subscriber line transmission.

Art Background

15 In transmission systems, in particular in digital subscriber line (DSL) transmission systems, conductors are used for transmitting signals. In many systems, pairs of conductors are used for transmitting one signal due to different earth potential. However, as distortions are not always equal on
20 each of the conductors, a common signal may be added to both conductors. At the receiving point, the common signal and thus distortions occurring during transmission may be computationally eliminated. However, still only one signal may be transmitted by one conductor pair.

25

The amount of users for such transmission systems and thus also the capacity requirements are increasing. Thus, there may be a need for an improved system and method extending the transmission capacities of a transmission system, for
30 instance being used for a DSL transmission.

Summary of the Invention

35 This need may be met by the subject matter according to the independent claims. Advantageous embodiments of the present invention are described by the dependent claims.

According to a first aspect of the invention there is provided a transmission system, in particular for a digital subscriber line transmission. The transmission system
5 comprises a first plurality of input terminals, a first plurality of output terminals, a plurality of conductor pairs, each conductor pair being assigned to one of the first plurality of input terminals and to one of the first plurality of output terminals, wherein each conductor pair is
10 formed by a first conductor and a corresponding second conductor, a second plurality of input terminals, and a second plurality of output terminals.

Each of the first plurality of input terminals is adapted to
15 supply a first part of a primary-type signal to a first conductor of one of the plurality of conductor pairs and a second part of the primary-type signal to the corresponding second conductor. The first part and the second part of the primary-type signal are indicative for one digital signal.

20 Each of the second plurality of input terminals is adapted to supply a first part of a secondary-type signal to at least one of the plurality of conductor pairs in addition to the first part and the second part of the primary-type signal.

25 Each of the second plurality of input terminals is further adapted to supply a second part of the secondary-type signal to at least a further one of the plurality of conductor pairs in addition to the first part and the second part of the primary-type signal. The first part and the second part of
30 the secondary-type signal are indicative for one digital signal.

It should be noted that each input terminal of the first plurality supplies a separate or single primary-type signal
35 and that each input terminal of the second plurality supplies a separate or single secondary-type signal.

Each conductor pair is adapted to transmit signals to an assigned one of the first plurality of output terminals and to at least two of the second plurality of output terminals. The number of input terminals of the first plurality of input
5 terminals corresponds to the number of input terminals of the second plurality of input terminals, to the number of output terminals of the first plurality of output terminals and to the number of output terminals of the second plurality of output terminals.

10

This aspect of the invention is based on the idea to provide an enhanced transmission system, in which the number of transmittable signals can be enhanced. This may be achieved by providing, in addition to the transmission channel being
15 provided by each conductor pair, so called "phantom channels". Phantom channels are based on the idea to add signals, in this context called secondary-type signals, here by the second plurality of input terminals, to the signals being supplied by the first plurality of input terminals, in
20 this context called primary-type signals.

The terms "primary-type" and "secondary-type" in this context may denote that the primary-type signals are supplied by the first plurality of input terminals, and that the secondary-
25 type signals are supplied by the second plurality of input terminals, providing the so-called phantom channels.

This may denote that, for each conductor pair, a primary-type signal is split in two parts and supplied to a conductor
30 pair, i.e., the first part of the signal is supplied to a first conductor and the second part of the signal is supplied to the second conductor of one conductor pair. Typically, the first part is a positive amount of the signal and the second part is a negative amount of the signal. However, this may
35 also be vice versa or any other kind of splitting.

In addition, a further, secondary-type signal is split in two parts, typically a positive amount and a negative amount, and these parts are supplied to different conductor pairs, at least two conductor pairs. In effect, one part is supplied to
5 the first and the second conductor of a conductor pair. The same signal may be supplied to a plurality of the conductor pairs.

Based on this approach, each conductor pair transmits several
10 signal or signal parts. Thus, "phantom channels" may be provided.

Conductor pairs in this context may denote any kind of conductor being able to transmit signals. Signals in this
15 context may denote optical or electrical signals. The conductors may be used in a pair configuration, wherein two conductors are typically used for one signal. Conductors in this context may be for instance wires, for example copper wires transmitting electrical signals. Conductors may also
20 denote optical fibres transmitting optical signals.

According to an embodiment of the invention, the number of signals being transmitted corresponds to the number of conductors being provided by the plurality of conductor
25 pairs.

This may denote that for each conductor pair representing one channel, one additional ("phantom") channel may be provided. In other words, if the number of conductor pairs in the
30 system is n , the number of transmittable signals is $2n$.

Another approach to reach a number $2n$ of transmittable signals is to use MIMO techniques. MIMO (multiple in multiple out) techniques are typically used in mobile communications.
35 Crosstalk is one of the main limiting factors in DSL transmission systems and significant efforts are done to cancel this. In order to use the nomenclature of mobile

communications, the DSL prior art uses arrays of decoupled SISO (single in single out) transmissions.

Using MIMO in DSL system, using $2n$ conductors/wires
5 corresponds to using $2n$ sending and $2n$ receiving antennas. Connections between a "sending antenna" and a "receiving antenna" that are not start and end point of the same wire arise through crosstalk. So, the former problem crosstalk may become a virtue and may take the place of multipath
10 transmission. The same holds for echos and other effects.

Generally, there are three main advantages for MIMO in comparison to SISO techniques, namely diversity gain, array gain, and spatial multiplexing gain.
15

Relevant here is the latter; where by a higher expense of signal processing complexity the throughput gains can be achieved.
20 Implementing MIMO to a DSL transmission system using the first plurality of input terminals and the first plurality of output terminals, may refer to an application of spatial multiplexing MIMO where the starting points of the wires (input terminals) are identified as sending antennas and the
25 endpoints (output terminals) as receiving antennas. The signal power can be significantly higher than in traditional DSL techniques as now crosstalk and even what otherwise was considered noise form transmission channels as explained above. Whether open loop or closed loop MIMO should be used,
30 can be adapted according to specific requirements. The DSL MIMO channel estimations may be much more stable than those of wireless transmission schemes simply because of a very limited range and magnitude of possible perturbations and a much longer time scale of these perturbations.

35 According to a further embodiment of the invention, each of the first plurality of output terminals is adapted to

retrieve the corresponding primary-type signal from the assigned conductor pair, wherein the retrieved signal is indicative for a digital signal, and each of the second plurality of output terminals is adapted to retrieve the
5 corresponding secondary-type signal by retrieving different signals from the plurality of conductor pairs and by determining the corresponding secondary-type signal from the retrieved different signals based on a predefined transmission scheme, wherein the corresponding secondary-type
10 signal is indicative for a digital signal.

Each of the first plurality of output terminals each being assigned to one of the plurality of conductor pairs may retrieve the primary-type signal which has been supplied
15 directly by the corresponding input terminal to this conductor pair. Each of the second plurality of output terminals may retrieve signals from all conductor pairs and may calculate the secondary-type signal being supplied by a corresponding input terminal based on the predefined
20 transmission scheme from all retrieved signal parts.

According to a further embodiment of the invention, the predefined transmission scheme is defined by a predefined transmission matrix.
25

The rank of such a transmission matrix may define the number of different signals that can be received. A transmission matrix may define transformations which occur to signals being transmitted over the conductor pairs.
30

According to a further embodiment of the invention, the predefined transmission matrix is defined dynamically based on channel estimations.

35 The channel estimations may be performed by measurement based on pilot signals. The transmission matrix may then be calculated and used for signal processing for transmission.

This may be based on MIMO techniques, in particular using spatial multiplexing gain, as mentioned above.

The transmission matrix may be a NxN matrix, wherein N
 5 corresponds to the number of conductors of the plurality of conductor pairs. According to a further embodiment of the invention, this matrix may acquire a rank N.

For a number of conductors equal to 2, the transmission
 10 matrix is a 4x4 matrix. Such a matrix may have for instance the form of

$$\begin{pmatrix} 1 & 0 & 1 & a \\ -1 & 0 & 1 & b \\ 0 & 1 & -1 & c \\ 0 & -1 & -1 & d \end{pmatrix}$$

15 There are a number of possible solutions to yield a rank 4 transmission matrix, for instance $a = b = 1, c = d = -1/2$.

According to general laws of transmission systems, the
 transmission scheme is further defined by a noise vector
 20 representing noise being added to the signals during transmission of the signals.

Typically, noise or distortions may occur during
 transmission. A basic formula for a definition of the
 25 transmission may be thus:

$$\vec{R} = \mathbf{H}\vec{Y} + \vec{N}$$

Here \mathbf{R} stands for the vector of the received signals, \mathbf{H} for
 30 the NxN transmission matrix, \mathbf{Y} for the vector of signals at the sender side, and \mathbf{N} for the vector of noise. The rank of

the transmission matrix may define the number of different signals that can be received.

According to a further embodiment of the invention, the
5 transmission system further comprises a plurality of
transforming units, wherein each of the first plurality of
input terminals is coupled to a corresponding one of the
plurality of transforming units and wherein each of the
10 second plurality of input terminals is coupled to a
corresponding one of the plurality of transforming units.

A transforming unit in this context may refer to a unit
comprising a transformer for transforming electrical energy
being indicative for an input signal of an input circuit into
15 electrical energy being indicative for signals to be
transmitted over the conductors. This may be performed by
inductively coupling. The transforming unit may also split
such a signal in two parts for two conductors.

20 According to a further embodiment of the invention, each
transforming unit is adapted to transform a digital signal in
an electrical signal and to split the electrical signal in a
first part and a second part.

25 The transforming unit may comprise a digital to analog
converter or an analog to digital converter for converting a
digital input signal into an electrical signal for
transmission and/or for converting the transmitted electrical
signal back to a digital signal.

30 According to a further embodiment of the invention, the
transmission system further comprises a further plurality of
transforming units, wherein each of the first plurality of
output terminals is coupled to a corresponding one of the
35 further plurality of transforming units and wherein each of
the second plurality of output terminals is coupled to a

corresponding one of the further plurality of transforming units.

A transforming unit in this context may refer to a unit
5 comprising a transformer for transforming electrical energy
being indicative for an input signal of an input circuit into
electrical energy being indicative for signals to be
transmitted over the conductors. This may be performed by
inductive coupling. The transforming unit may also split such
10 a signal in two parts for being supplied to different
conductors.

According to a further embodiment of the invention, each
transforming unit is adapted to transform a first part and a
15 second part of an electrical signal in a digital signal
Also the transforming units of output terminals may comprise
a digital to analog converter or an analog to digital
converter for converting a digital input signal into an
electrical signal for transmission and/or for converting the
20 transmitted electrical signal back to a digital signal.

According to a further embodiment of the invention, the
number of input terminals of the first plurality of input
terminals, the number of input terminals of the second
25 plurality of input terminals, the number of output terminals
of the first plurality of output terminals and the number of
output terminals of the second plurality of output terminals
is two.

30 According to this particular embodiment, the transmission
matrix would be a 4x4 matrix as described above. The number
of conductor pairs would be 2 and thus the number of
conductors would be 4.

35 According to a further embodiment of the invention, a
transmitter is provided, in particular for being connectable
to a digital subscriber line. The transmitter comprises a

first plurality of input terminals being connectable to a plurality of conductor pairs, each conductor pair being assigned to one of the first plurality of input terminals, wherein each conductor pair is formed by a first conductor
5 and a corresponding second conductor, and a second plurality of input terminals. Each of the first plurality of input terminals is adapted to supply a first part of a primary-type signal to a first conductor of one of the plurality of conductor pairs and a second part of the primary-type signal
10 to the corresponding second conductor, wherein the first part and the second part of the primary-type signal are indicative for one digital signal. Each of the second plurality of input terminals is adapted to supply a first part of a secondary-type signal to at least one of the plurality of conductor
15 pairs in addition to the first part and the second part of the primary-type signal, and is adapted to supply a second part of the secondary-type signal to at least a further one of the plurality of conductor pairs in addition to the first part and the second part of the primary-type signal, wherein
20 the first part and the second part of the secondary-type signal are indicative for one digital signal. Each conductor pair is adapted to transmit signals to an assigned one of a first plurality of output terminals and to at least two of a second plurality of output terminals. The number of input
25 terminals of the first plurality of input terminals corresponds to the number of input terminals of the second plurality of input terminals, to the number of output terminals of the first plurality of output terminals and to the number of output terminals of the second plurality of
30 output terminals.

According to a further embodiment, a receiver, in particular for receiving signals from a digital subscriber line, is provided. The receiver comprises a first plurality of
35 terminals being connectable to a plurality of conductor pairs, each conductor pair being assigned to one of the first plurality of terminals, wherein each conductor pair is formed

by a first conductor and a corresponding second conductor,
and a second plurality of terminals. The receiver is adapted
to receive, via the first plurality of terminals and the
second of output terminals, signals from a transmitter via
5 the plurality of conductor pairs. The transmitter comprises a
first plurality of input terminals being connectable to the
plurality of conductor pairs, each conductor pair being
assigned to one of the first plurality of input terminals,
and a second plurality of input terminals. Each of the first
10 plurality of input terminals is adapted to supply a first
part of a primary-type signal to a first conductor of one of
the plurality of conductor pairs and a second part of the
primary-type signal to the corresponding second conductor,
wherein the first part and the second part of the primary-
15 type signal are indicative for one digital signal. Each of
the second plurality of input terminals is adapted to supply
a first part of a secondary-type signal to at least one of
the plurality of conductor pairs in addition to the first
part and the second part of the primary-type signal, and is
20 adapted to supply a second part of the secondary-type signal
to at least a further one of the plurality of conductor pairs
in addition to the first part and the second part of the
primary-type signal, wherein the first part and the second
part of the secondary-type signal are indicative for one
25 digital signal. Each conductor pair is adapted to transmit
signals to an assigned one of the first plurality of
terminals and to at least two of the second plurality of
terminals, wherein the number of input terminals of the first
plurality of input terminals corresponds to the number of
30 input terminals of the second plurality of input terminals,
to the number of terminals of the first plurality of
terminals and to the number of terminals of the second
plurality of terminals.

35 According to a second aspect of the invention, there is
provided a method for transmitting signals in a transmission
system, in particular for a digital subscriber line

transmission. The transmission system comprises a first plurality of input terminals, a first plurality of output terminals, a plurality of conductor pairs, each conductor pair being assigned to one of the first plurality of input terminals and to one of the first plurality of output terminals, wherein each conductor pair is formed by a first conductor and a corresponding second conductor, a second plurality of input terminals, and a second plurality of output terminals. The method comprises (i) supplying, by each of the first plurality of input terminals, a first part of a primary-type signal to a first conductor of one of the plurality of conductor pairs and a second part of the primary-type signal to the corresponding second conductor, wherein the first part and the second part of the primary-type signal are indicative for one digital signal, (ii) supplying, by each of the second plurality of input terminals, a first part of a secondary-type signal to at least one of the plurality of conductor pairs in addition to the first part and the second part of the primary-type signal, (iii) supplying, by each of the second plurality of input terminals, a second part of the secondary-type signal to at least a further one of the plurality of conductor pairs in addition to the first part and the second part of the primary-type signal, wherein the first part the second part of the secondary-type signal are indicative for one digital signal, and (iv) transmitting, by each conductor pair, signals to an assigned one of the first plurality of output terminals and to at least two of the second plurality of output terminals, wherein the number of input terminals of the first plurality of input terminals corresponds to the number of input terminals of the second plurality of input terminals, to the number of output terminals of the first plurality of output terminals and to the number of output terminals of the second plurality of output terminals.

35

Generally herein, the system and embodiments of the system according to the first aspect may include units or devices

for performing one or more functions described with regard to the second aspect or an embodiment thereof. Vice versa, the method and embodiments thereof according to the second aspect may include performing one or more functions described with regard to the first aspect or an embodiment thereof.

According to a third aspect of the herein disclosed subject-matter, a computer program for transmitting signals in a transmission system is provided, the computer program being adapted for, when executed by a data processor assembly, controlling the method as set forth in the second aspect or an embodiment thereof.

As used herein, reference to a computer program is intended to be equivalent to a reference to a program element and/or a computer readable medium containing instructions for controlling a computer system to coordinate the performance of the above described method.

The computer program may be implemented as computer readable instruction code by use of any suitable programming language, such as, for example, JAVA, C++, and may be stored on a computer-readable medium (removable disk, volatile or non-volatile memory, embedded memory/processor, etc.). The instruction code is operable to program a computer or any other programmable device to carry out the intended functions. The computer program may be available from a network, such as the World Wide Web, from which it may be downloaded.

The herein disclosed subject matter may be realized by means of a computer program respectively software. However, the herein disclosed subject matter may also be realized by means of one or more specific electronic circuits respectively hardware. Furthermore, the herein disclosed subject matter may also be realized in a hybrid form, i.e. in a combination of software modules and hardware modules.

In the above there have been described and in the following there will be described exemplary embodiments of the subject matter disclosed herein with reference to a transmission
5 system and a method of transmitting signals in a transmission system. It has to be pointed out that of course any combination of features relating to different aspects of the herein disclosed subject matter is also possible. In particular, some embodiments have been described with
10 reference to apparatus type embodiments whereas other embodiments have been described with reference to method type embodiments. However, a person skilled in the art will gather from the above and the following description that, unless otherwise notified, in addition to any combination of
15 features belonging to one aspect also any combination between features relating to different aspects or embodiments, for example even between features of the apparatus type embodiments and features of the method type embodiments is considered to be disclosed with this application.

20 The aspects and embodiments defined above and further aspects and embodiments of the present invention are apparent from the examples to be described hereinafter and are explained with reference to the drawings, but to which the invention is
25 not limited.

Brief Description of the Drawing

30 Figure 1 shows a transmission system according to an exemplary embodiment of the present invention.

Figure 2 shows a part of a transmission system according to an exemplary embodiment of the present invention.

35 Figure 3 shows a part of a transmission system according to an exemplary embodiment of the present invention.

Figure 4 shows a part of a transmission system according to an exemplary embodiment of the present invention.

5 Figure 5 shows a transmission system according to an exemplary embodiment of the present invention.

It is noted that in different figures, similar or identical elements are provided with the same reference signs.

10

Detailed Description

In the following, embodiments of the herein disclosed subject
15 matter are illustrated with reference to the drawings and reference to aspects of current standards, such as DSL, and their further developments. However, such reference to current standards is only exemplary and should not be considered as limiting the scope of the claims.

20

Figure 1 shows a transmission system 100 according to an exemplary embodiment of the invention. The transmission system may be used in particular for a digital subscriber line transmission.

25

The transmission system comprises a first plurality of input terminals 110, 120 and a corresponding first plurality of
output terminals 111, 121. The transmission system 100
comprises further a plurality of conductor pairs 150, each
30 conductor pair being assigned to one of the first plurality of input terminals 110, 120 and to one of the first plurality of output terminals 111, 121. Each conductor pair is formed by a first conductor 150 and a corresponding second conductor 150.

35

The transmission system 100 further comprises a second plurality of input terminals 130, 140 and a corresponding second plurality of output terminals 131, 141.

5 Each of the first plurality of input terminals 110, 120 is adapted to supply a first part of a primary-type signal to a first conductor of one of the plurality of conductor pairs 150 and a second part of the primary-type signal to the corresponding second conductor. The first part and the second
10 part of the primary-type signal are indicative for one digital signal.

Each of the second plurality of input terminals 130, 140 is adapted to supply a first part of a secondary-type signal to
15 at least one of the plurality of conductor pairs 150 in addition to the first part and the second part of the primary-type signal. Further, each of the second plurality of input terminals 130, 140 is adapted to supply a second part of the secondary-type signal to at least a further one of the
20 plurality of conductor pairs 150 in addition to the first part and the second part of the primary-type signal. As the primary-type signals being supplied by the first plurality of input terminals 110, 120, also the first part and the second part of the secondary-type signal being supplied by the
25 second plurality of input terminals 130, 140 are indicative for one digital signal.

Each conductor pair 150 is adapted to transmit signals to an assigned one of the first plurality of output terminals 111, 121 and to at least two of the second plurality of output
30 terminals 131, 141. Each of the second plurality of terminals 131, 141 is adapted to retrieve the signal being supplied by the corresponding input terminal by receiving all signals of all conductor pairs and by performing some calculations on
35 the received signals.

The number of input terminals of the first plurality of input terminals 110, 120 corresponds to the number of input terminals of the second plurality of input terminals 130, 140, to the number of output terminals of the first plurality
5 of output terminals 111, 121 and to the number of output terminals of the second plurality of output terminals 131, 141. This may denote that the number of conductors 150 corresponds to the number of transmitted signals.

10 The idea of this invention is to increase the DSL throughput by introducing further phantom channels, i.e., virtual channels in addition to the physical channels being provided by the direct coupling of the first plurality of input terminals 110, 120, the conductor pairs 150 and the first
15 plurality of corresponding output terminals 111, 121.

The data transmission speed over DSL connections may be further increased by a combination of three techniques, namely Phantom channels, vectoring, and EFM bonding.
20 Phantom DSL according to the herein described embodiments allows to introduce so called phantom channels so that the transmission matrix for a DSL connection using four wires can have a rank up to four - this means that the throughput is
25 four times that of one wire. However, the upper limit might be a rank of four.

The basic principle of DSL signal transmission is shown in Figure 2. A signal V_{sig} is provided to a transformer 210 of a
30 transmission system 200. The transformer 210 splits the signal into $V+$ and $V-$, which may be typically $V+ = -V-$. Any distortion 201 which may interfere with the wires or conductors 250 is considered in one case as being equal on the two wires. A transformer 211 builds again V'_{sig} , which may
35 be usually $V'_{sig} = 1/2(V'+ - V'-)$, wherein the distortion should be canceled out.

So, only one signal is transferred over the two wires. The reason is that it is assumed to not be able to cancel the distortion otherwise. In addition, the basic assumption of having fully equal distortion on the two wires doesn't hold
 5 in general fully.

Thus, according to a further transmission system as shown in Figure 3, a symmetric, common part P may be added via input terminal 330 to the signal V_{sig} , wherein the common part would
 10 cancel at the receiver via output terminal 331. The common part P may be added to V+ and V- as new signal. The transformer builds again, here $V'_{sig}=1/2(V'+ + P' - V'- - P')$, wherein the distortion and the additional signal P' cancels out.

15

In Figure 4, a transmission system 400 with one phantom channel is shown. The idea of phantom channels is now to first double the setup, i.e. use two pairs of wires. Then, also the signal P_{sig} is split into two parts P+ and P- and
 20 regained at the receiver by taking the difference of the sums of the signals on the two wire pairs.

The transmission system 400 comprises a second input terminal 420, corresponding conductor/wire pair and output terminal
 25 421. A signal W_{sig} is transmitted over this wire pair. Via input terminal 330, the two parts of signal P_{sig} is added to both wire pairs via lines 430. At the receiving side, the common part representing signal P'_{sig} is taken via lines 431.

30 The basic formula of a transmission over n channel is

$$\vec{R} = \mathbf{H}\vec{Y} + \vec{N}$$

Here \mathbf{R} stands for the vector of the received signals, \mathbf{H} for
 35 the nxn transmission matrix, \mathbf{Y} for the vector of signals at the sender side, and \mathbf{N} for the vector of noise. The rank of

the transmission matrix gives the number of different signals that can be received.

The phantom channel techniques so far have a rank 3
 5 transmission matrix despite using 4 wires, i.e. 4
 transmission channels. According to the so far described
 embodiments, the transmission matrix can theoretically reach
 rank $n-1$ when n is the number of copper wires used. According
 to the embodiments shown in Figures 1 and 5 an n -th
 10 transmission channel is introduced.

When looking at the above described setup (together with the
 working assumptions), the transmission matrix \mathbf{H} may assume
 the following form:

15

$$\begin{pmatrix} 1 & 0 & 1 & a \\ -1 & 0 & 1 & b \\ 0 & 1 & -1 & c \\ 0 & -1 & -1 & d \end{pmatrix}$$

A possible solution of this matrix may lead to $a = b = 1$, $c =$
 $d = -1/2$. Translating this result into the above setup could
 20 look like the transmission system as shown in Figure 5.

As explained above, the transmission system 500 of Figure 5
 has a rank 4 transition matrix and in particular a fourth
 signal Q at the transmitter side and Q' at the receiver side.
 25 In addition to the system 400 of Figure 4, this system
 comprises a second phantom channel being provided by the
 transformer 540, supplying the additional signal Q_{sig} and the
 corresponding transformer 541 retrieving the additional
 signal Q'_{sig} .

30

Thus, an extended transmission system may be achieved,
 wherein the overall throughput is enhanced. The additional
 signals may be added to the physical wires in any

combination. Thus, the additional signal Q_{sig} may be split into $Q+$ and $Q-$, wherein $Q+$ is added to the transmission wire of V and W , and $Q-$ is only added to the transmission wire of V or to the transmission wires of V and W .

5

It should be noted that this is just one example. Of course, the additional (secondary-type) signals may be added to the physical wires in any suitable combination. Typically, the additional signal will be added to two of the primary-type

10

signals. That means, in this embodiment, the additional signal Q will be added as a first part $Q+$ to the first part $V+$ and the second part $V-$ of signal V and to the first part $W+$ and the second part $W-$ of signal W . In addition, the second part $Q-$ of the signal Q will be added to the first

15

part $V+$ and the second part $V-$ of signal V . In any case, one part of the additional secondary-type signal will be added to both conductors of a conductor pair.

20

Having regard to the subject matter disclosed herein, it should be mentioned that, although some embodiments refer to an "input terminal", "transformer", etc., it should be understood that each of these references is considered to implicitly disclose a respective reference to the general term "transforming unit" or, in still other embodiments, to the term "unit providing transforming characteristics". Also other terms which relate to specific standards or specific communication techniques are considered to implicitly disclose the respective general term with the desired functionality.

25
30

According to embodiments of the invention, any suitable entity (e.g. components, units and devices) disclosed herein, e.g. transforming unit, are at least in part provided in the form of respective computer programs which enable a processor device to provide the functionality of the respective entities as disclosed herein. According to other embodiments, any suitable entity disclosed herein may be provided in

35

hardware. According to other - hybrid - embodiments, some entities may be provided in software while other entities are provided in hardware.

- 5 It should be noted that any entity disclosed herein (e.g. components, units and devices) are not limited to a dedicated entity as described in some embodiments. Rather, the herein disclosed subject matter may be implemented in various ways and with various granularities on device level while still
- 10 providing the desired functionality. Further, it should be noted that according to embodiments a separate entity (e.g. a software module, a hardware module or a hybrid module) may be provided for each of the functions disclosed herein. According to other embodiments, an entity (e.g. a software
- 15 module, a hardware module or a hybrid module (combined software/hardware module)) is configured for providing two or more functions as disclosed herein.

- It should be noted that the term "comprising" does not
- 20 exclude other elements or steps. It may also be possible in further refinements of the invention to combine features from different embodiments described herein above. It should also be noted that reference signs in the claims should not be construed as limiting the scope of the claims.

25

List of reference signs:

	100	Transmission system
	110	Input terminal
5	111	Output terminal
	120	Input terminal
	121	Output terminal
	130	Input terminal
	131	Output terminal
10	140	Input terminal
	141	Output terminal
	150	Conductor
	200	Transmission system
15	201	Distortions
	210	Input transformer
	211	Output transformer
	250	Conductor
20	300	Transmission system
	330	Input transformer
	331	Output transformer
	400	Transmission system
25	430	Additional signal
	431	Additional signal
	500	Transmission system
	540	Input transformer
30	541	Output transformer

CLAIMS:

1. A transmission system (100), in particular for a digital subscriber line transmission, the transmission system
- 5 comprising
- a first plurality of input terminals (110, 120),
 - a first plurality of output terminals (111, 121),
 - a plurality of conductor pairs (150), each conductor pair being assigned to one of the first plurality of input
- 10 terminals (110, 120) and to one of the first plurality of output terminals (111, 121), wherein each conductor pair is formed by a first conductor and a corresponding second conductor,
- a second plurality of input terminals (130, 140), and
 - 15 a second plurality of output terminals (131, 141),
- wherein each of the first plurality of input terminals (110, 120) is adapted to supply a first part of a primary-type signal to a first conductor of one of the plurality of conductor pairs (150) and a second part of the primary-type
- 20 signal to the corresponding second conductor, wherein the first part and the second part of the primary-type signal are indicative for one digital signal,
- wherein each of the second plurality of input terminals (130, 140) is adapted to supply a first part of a secondary-type signal to at least one of the plurality of conductor
- 25 pairs (150) in addition to the first part and the second part of the primary-type signal, and is adapted to supply a second part of the secondary-type signal to at least a further one of the plurality of conductor pairs (150) in addition to the
- 30 first part and the second part of the primary-type signal, wherein the first part and the second part of the secondary-type signal are indicative for one digital signal,
- wherein each conductor pair (150) is adapted to transmit signals to an assigned one of the first plurality of output
- 35 terminals (111, 121) and to at least two of the second plurality of output terminals (131, 141), and

wherein the number of input terminals of the first plurality of input terminals (110, 120) corresponds to the number of input terminals of the second plurality of input terminals (130, 140), to the number of output terminals of the first plurality of output terminals (111, 121) and to the number of output terminals of the second plurality of output terminals (131, 141).

2. The transmission system (100) as set forth in claim 1, wherein the number of signals being transmitted corresponds to the number of conductors being provided by the plurality of conductor pairs (150).

3. The transmission system (100) as set forth in any one of the preceding claims,

wherein each of the first plurality of output terminals (111, 121) is adapted to retrieve a primary-type signal from the assigned conductor pair (150), wherein the retrieved primary-type signal is indicative for a respective digital signal, and

wherein each of the second plurality of output terminals (131, 141) is adapted to retrieve a secondary-type signal by retrieving different signals from the plurality of conductor pairs (150) and by determining the secondary-type signal from the retrieved different signals based on a predefined transmission scheme, wherein the secondary-type signal is indicative for a respective digital signal.

4. The transmission system (100) as set forth in claim 3, wherein the predefined transmission scheme is defined by a predefined transmission matrix.

5. The transmission system (100) as set forth in claim 4, wherein the predefined transmission matrix is defined dynamically based on channel estimations.

6. The transmission system (100) as set forth in any one of the claims 4 or 5, wherein the predefined transmission matrix is a $N \times N$ transmission matrix of rank N , wherein N corresponds to the number of conductors of the plurality of conductor
5 pairs (150).

7. The transmission system (100) as set forth in any one of the claims 4 to 6, wherein the transmission scheme is further defined by a noise vector representing noise being added to
10 the signals during transmission of the signals.

8. The transmission system (100) as set forth in any one of the preceding claims, the transmission system (100) further comprising

15 a plurality of transforming units (210, 330, 420, 540), wherein each of the first plurality of input terminals (110, 120) is coupled to a corresponding one of the plurality of transforming units (210, 420) and wherein each of the second plurality of input terminals (130, 140) is coupled to a
20 corresponding one of the plurality of transforming units (330, 540).

9. The transmission system (100) as set forth in claim 8, wherein each transforming unit (210, 330, 420, 540) is
25 adapted to transform a digital signal in an electrical signal and to split the electrical signal in a first part and a second part.

10. The transmission system (100) as set forth in any one of the preceding claims, the transmission system (100) further comprising

30 a further plurality of transforming units (211, 331, 421, 541), wherein each of the first plurality of output terminals (111, 121) is coupled to a corresponding one of the further plurality of transforming units (211, 421) and
35 wherein each of the second plurality of output terminals

(131, 141) is coupled to a corresponding one of the further plurality of transforming units (331, 541).

11. The transmission system (100) as set forth in claim 10,
5 wherein each transforming unit (211, 331, 421, 541) is adapted to transform a first part and a second part of an electrical signal in a digital signal.

12. The transmission system (100) as set forth in any one of
10 the preceding claims, wherein the number of input terminals of the first plurality of input terminals (110, 120), the number of input terminals of the second plurality of input terminals (130, 140), the number of output terminals of the first plurality of output terminals (111, 121) and the number
15 of output terminals of the second plurality of output terminals (131, 141) is two.

13. A transmitter, in particular for being connectable to a digital subscriber line, the transmitter comprising
20 a first plurality of input terminals (110, 120) being connectable to a plurality of conductor pairs (150), each conductor pair being assigned to one of the first plurality of input terminals (110, 120), wherein each conductor pair is formed by a first conductor and a corresponding second
25 conductor, and
a second plurality of input terminals (130, 140),
wherein each of the first plurality of input terminals (110, 120) is adapted to supply a first part of a primary-type signal to a first conductor of one of the plurality of
30 conductor pairs (150) and a second part of the primary-type signal to the corresponding second conductor, wherein the first part and the second part of the primary-type signal are indicative for one digital signal,
wherein each of the second plurality of input terminals
35 (130, 140) is adapted to supply a first part of a secondary-type signal to at least one of the plurality of conductor pairs (150) in addition to the first part and the second part

of the primary-type signal, and is adapted to supply a second part of the secondary-type signal to at least a further one of the plurality of conductor pairs (150) in addition to the first part and the second part of the primary-type signal,
5 wherein the first part and the second part of the secondary-type signal are indicative for one digital signal,
wherein each conductor pair (150) is adapted to transmit signals to an assigned one of a first plurality of output terminals (111, 121) and to at least two of a second
10 plurality of output terminals (131, 141), and
wherein the number of input terminals of the first plurality of input terminals (110, 120) corresponds to the number of input terminals of the second plurality of input terminals (130, 140), to the number of output terminals of
15 the first plurality of output terminals (111, 121) and to the number of output terminals of the second plurality of output terminals (131, 141).

14. A receiver, in particular for receiving signals from a
20 digital subscriber line, the receiver comprising
a first plurality of terminals (111, 121) being connectable to a plurality of conductor pairs (150), each conductor pair being assigned to one of the first plurality of terminals, wherein each conductor pair is formed by a
25 first conductor and a corresponding second conductor, and
a second plurality of terminals (131, 141),
the receiver being adapted to receive, via the first plurality of terminals and the second plurality of terminals, signals from a transmitter via the plurality of conductor
30 pairs,
the transmitter comprising
a first plurality of input terminals (110, 120) being connectable to the plurality of conductor pairs (150), each conductor pair being assigned to one of the first
35 plurality of input terminals (110, 120), and
a second plurality of input terminals (130, 140),

wherein each of the first plurality of input terminals (110, 120) is adapted to supply a first part of a primary-type signal to a first conductor of one of the plurality of conductor pairs (150) and a second part of the primary-type signal to the corresponding second conductor, wherein the first part and the second part of the primary-type signal are indicative for one digital signal,

wherein each of the second plurality of input terminals (130, 140) is adapted to supply a first part of a secondary-type signal to at least one of the plurality of conductor pairs (150) in addition to the first part and the second part of the primary-type signal, and is adapted to supply a second part of the secondary-type signal to at least a further one of the plurality of conductor pairs (150) in addition to the first part and the second part of the primary-type signal, wherein the first part and the second part of the secondary-type signal are indicative for one digital signal,

wherein each conductor pair (150) is adapted to transmit signals to an assigned one of the first plurality of terminals (111, 121) and to at least two of the second plurality of terminals (131, 141), and

wherein the number of input terminals of the first plurality of input terminals (110, 120) corresponds to the number of input terminals of the second plurality of input terminals (130, 140), to the number of terminals of the first plurality of terminals (111, 121) and to the number of terminals of the second plurality of terminals (131, 141).

15. A method for transmitting signals in a transmission system (100), in particular for a digital subscriber line transmission, the transmission system (100) comprising a first plurality of input terminals (110, 120), a first plurality of output terminals (111, 121), a plurality of conductor pairs (150), each conductor pair being assigned to one of the first plurality of input terminals (110, 120) and to one of the first plurality of output terminals (111, 121),

wherein each conductor pair (150) is formed by a first conductor and a corresponding second conductor, a second plurality of input terminals (130, 140), and a second plurality of output terminals (131, 141), the method

5 comprising

supplying, by each of the first plurality of input terminals (110, 120), a first part of a primary-type signal to a first conductor of one of the plurality of conductor pairs (150) and a second part of the primary-type signal to
10 the corresponding second conductor, wherein the first part and the second part of the primary-type signal are indicative for one digital signal,

supplying, by each of the second plurality of input terminals (130, 140), a first part of a secondary-type signal to at least one of the plurality of conductor pairs (150) in
15 addition to the first part and the second part of the primary-type signal,

supplying, by each of the second plurality of input terminals (130, 140), a second part of the secondary-type
20 signal to at least a further one of the plurality of conductor pairs (150) in addition to the first part and the second part of the primary-type signal, wherein the first part and the second part of the secondary-type signal are indicative for one digital signal, and

25 transmitting, by each conductor pair (150), signals to an assigned one of the first plurality of output terminals (111, 121) and to at least two of the second plurality of output terminals (131, 141),

wherein the number of input terminals of the first
30 plurality of input terminals (110, 120) corresponds to the number of input terminals of the second plurality of input terminals (130, 140), to the number of output terminals of the first plurality of output terminals (111, 121) and to the number of output terminals of the second plurality of output
35 terminals (131, 141).

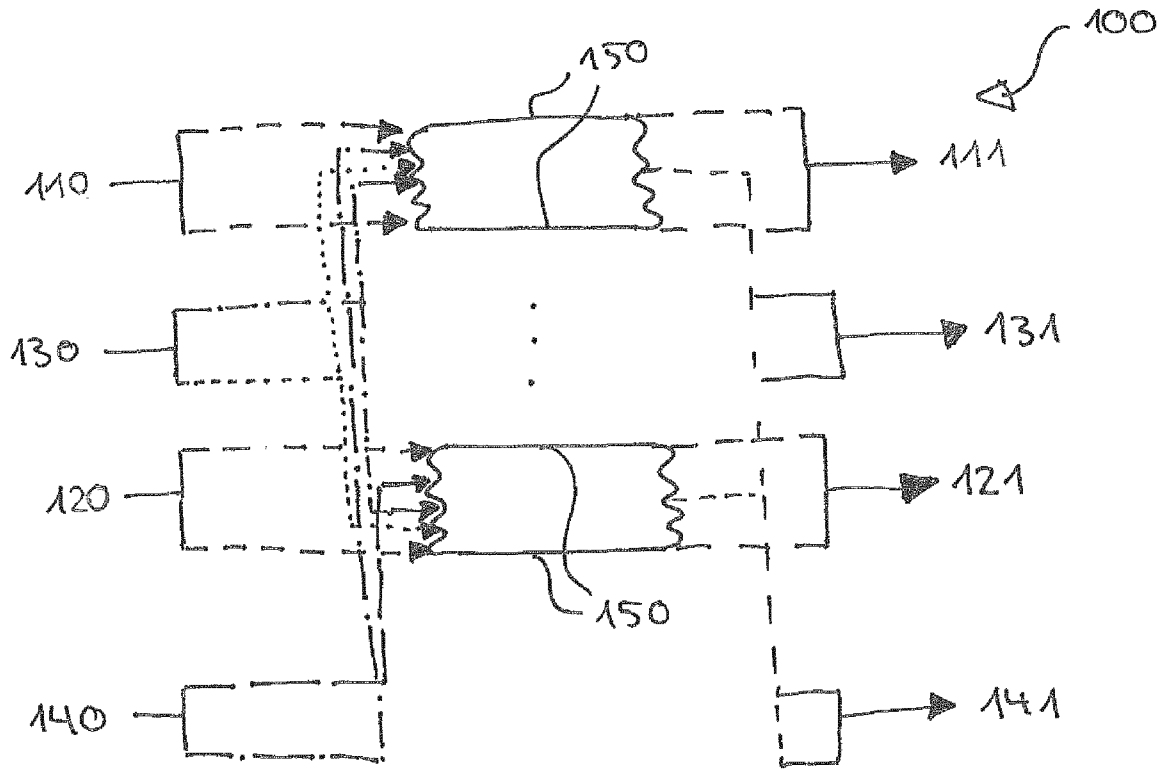

Fig. 1

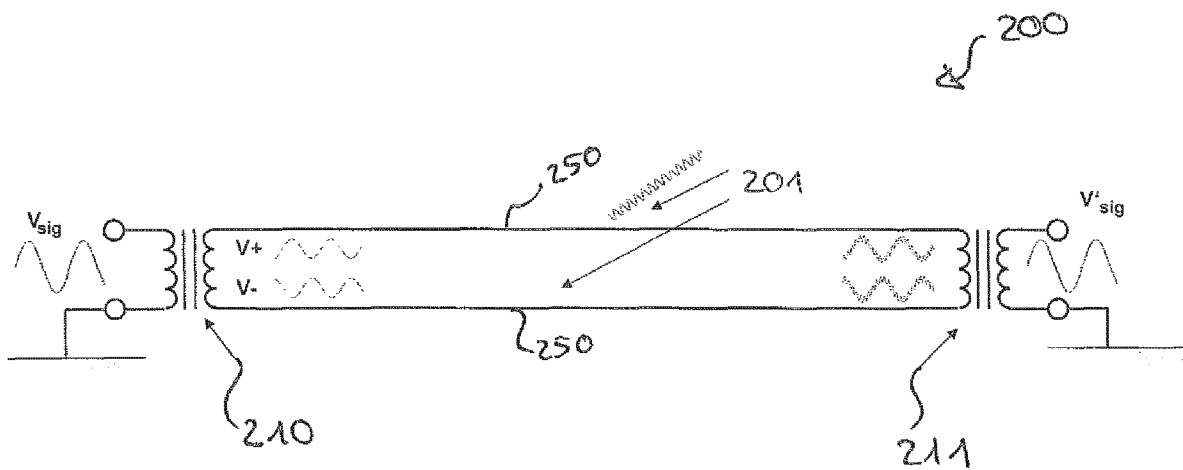

Fig. 2

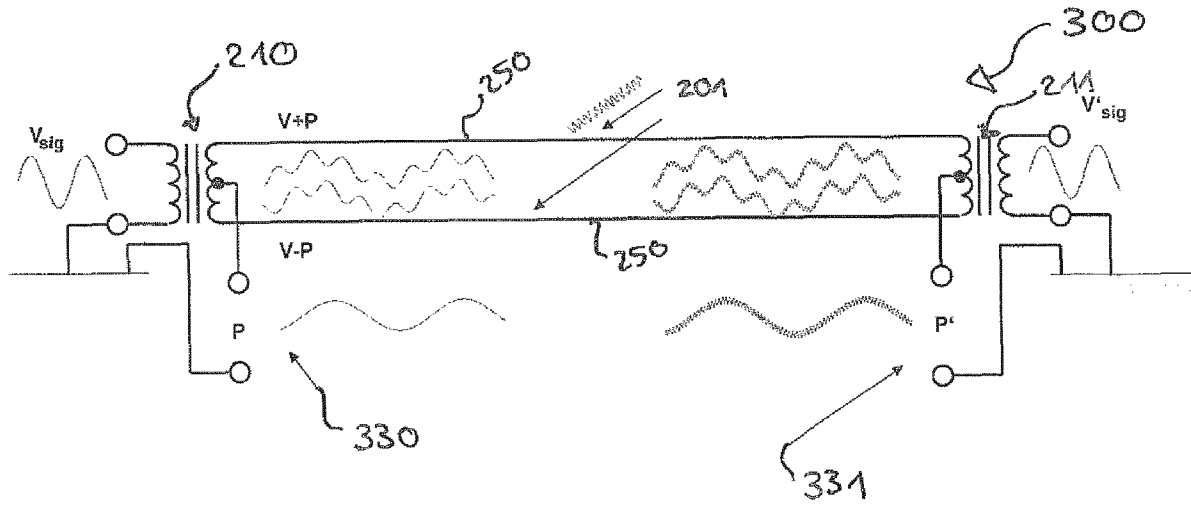

Fig. 3

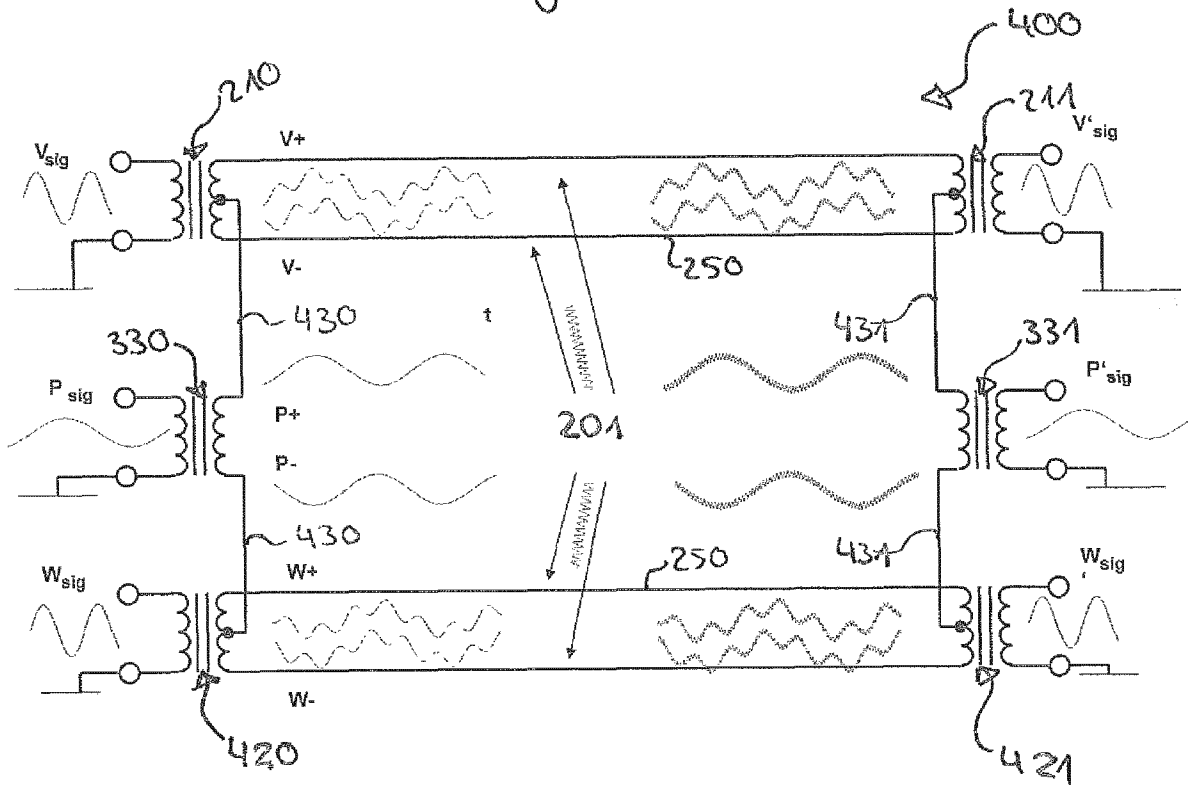

Fig. 4

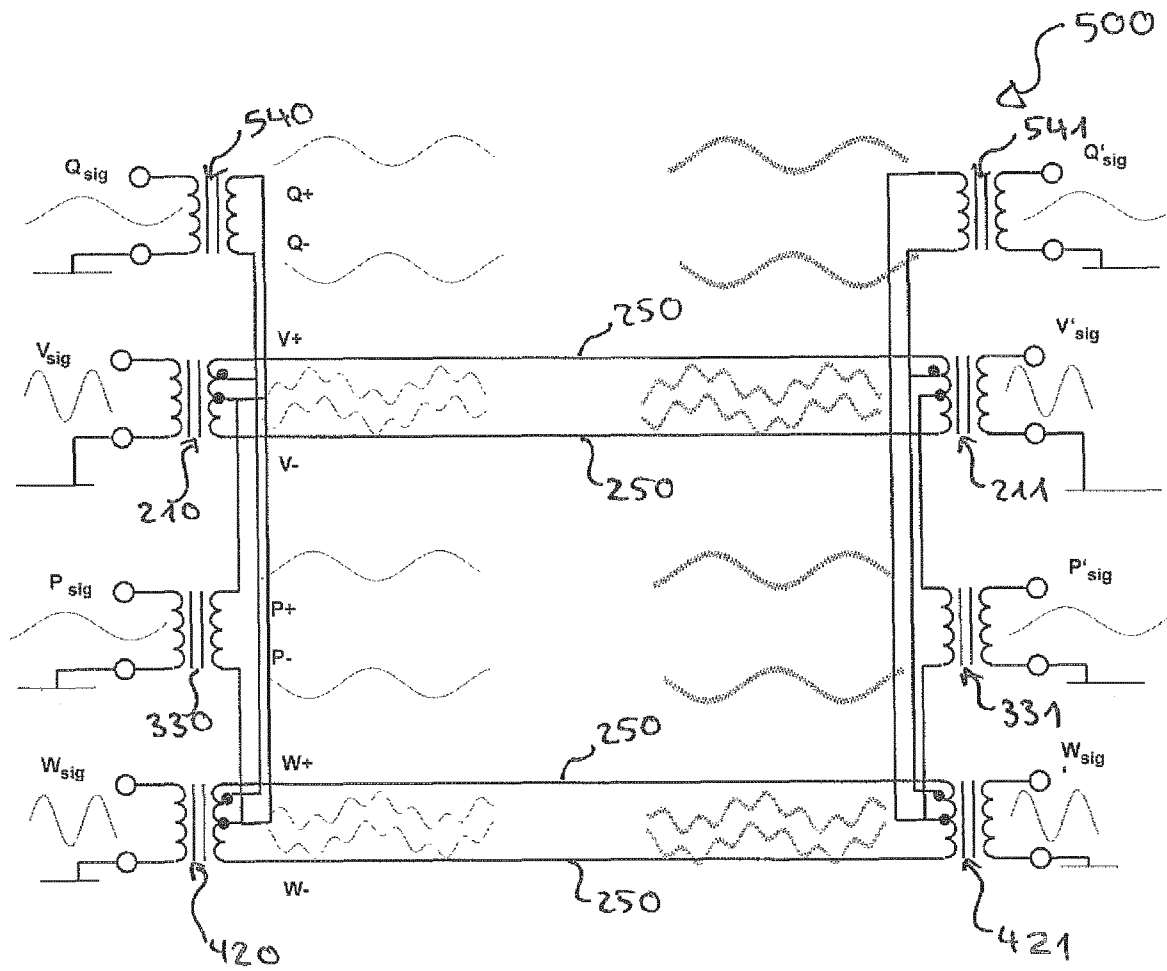

Fig. 5

INTERNATIONAL SEARCH REPORT

International application No
PCT/EP2012/055814

A. CLASSIFICATION OF SUBJECT MATTER
INV. H04B3/00
ADD.
According to International Patent Classification (IPC) or to both national classification and IPC

B. FIELDS SEARCHED
Minimum documentation searched (classification system followed by classification symbols)
H04B

Documentation searched other than minimum documentation to the extent that such documents are included in the fields searched

Electronic data base consulted during the international search (name of data base and, where practicable, search terms used)
EPO-Internal, INSPEC, WPI Data

C. DOCUMENTS CONSIDERED TO BE RELEVANT

Category*	Citation of document, with indication, where appropriate, of the relevant passages	Relevant to claim No.
X	EP 2 091 196 A1 (ALCATEL LUCENT [FR]) 19 August 2009 (2009-08-19) abstract; figures 1-4 paragraph [0001] - paragraph [0029] paragraph [0032] - paragraph [0070] -----	1-15
X	US 2011/051593 A1 (CIOFFI JOHN M [US] ET AL) 3 March 2011 (2011-03-03) abstract; figures 1-3 paragraph [0003] - paragraph [0005] paragraph [0018] - paragraph [0019] paragraph [0032] - paragraph [0053] ----- -/--	1-15

Further documents are listed in the continuation of Box C.

See patent family annex.

* Special categories of cited documents :

- "A" document defining the general state of the art which is not considered to be of particular relevance
- "E" earlier application or patent but published on or after the international filing date
- "L" document which may throw doubts on priority claim(s) or which is cited to establish the publication date of another citation or other special reason (as specified)
- "O" document referring to an oral disclosure, use, exhibition or other means
- "P" document published prior to the international filing date but later than the priority date claimed

- "T" later document published after the international filing date or priority date and not in conflict with the application but cited to understand the principle or theory underlying the invention
- "X" document of particular relevance; the claimed invention cannot be considered novel or cannot be considered to involve an inventive step when the document is taken alone
- "Y" document of particular relevance; the claimed invention cannot be considered to involve an inventive step when the document is combined with one or more other such documents, such combination being obvious to a person skilled in the art
- "&" document member of the same patent family

Date of the actual completion of the international search 20 November 2012	Date of mailing of the international search report 28/11/2012
Name and mailing address of the ISA/ European Patent Office, P.B. 5818 Patentlaan 2 NL - 2280 HV Rijswijk Tel. (+31-70) 340-2040, Fax: (+31-70) 340-3016	Authorized officer Galli, Paolo

INTERNATIONAL SEARCH REPORT

International application No
PCT/EP2012/055814

C(Continuation). DOCUMENTS CONSIDERED TO BE RELEVANT		
Category*	Citation of document, with indication, where appropriate, of the relevant passages	Relevant to claim No.
A	<p>BIN LEE ET AL: "Binder MIMO Channels", IEEE TRANSACTIONS ON COMMUNICATIONS, IEEE SERVICE CENTER, PISCATAWAY, NJ. USA, vol. 55, no. 8, 1 August 2007 (2007-08-01) , pages 1617-1628, XP011190563, ISSN: 0090-6778, DOI: 10.1109/TCOMM.2007.902597 abstract * Sections I and II * -----</p>	1-15

INTERNATIONAL SEARCH REPORT

Information on patent family members

International application No

PCT/EP2012/055814

Patent document cited in search report	Publication date	Patent family member(s)	Publication date
EP 2091196	A1	19-08-2009	NONE
US 2011051593	A1	03-03-2011	CN 101218776 A 09-07-2008
			EP 1880503 A1 23-01-2008
			JP 4918087 B2 18-04-2012
			JP 2008541594 A 20-11-2008
			US 2006268966 A1 30-11-2006
			US 2011051593 A1 03-03-2011
			WO 2006120510 A1 16-11-2006