

C. W. BRAY.
 APPARATUS FOR OPENING PACKS.
 APPLICATION FILED JAN. 30, 1908.

997,958.

Patented July 18, 1911.

3 SHEETS—SHEET 1.

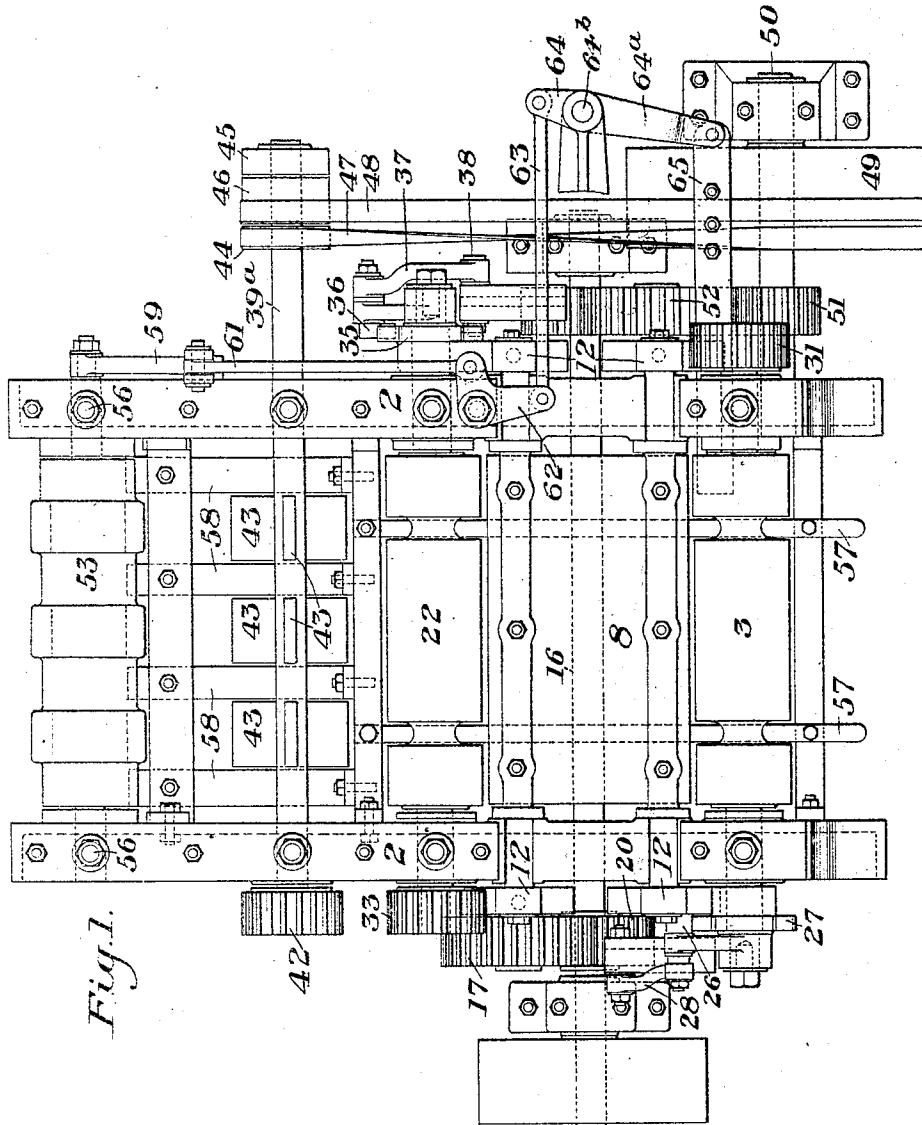

Fig. 1.

WITNESSES

R. A. Baldwin
W. W. Swartz

INVENTOR

Chas. W. Bray
 by *Baker, Byrnes & Parmelee,*
 his Atty.

C. W. BRAY.
 APPARATUS FOR OPENING PACKS.
 APPLICATION FILED JAN. 30, 1908.

997,958.

Patented July 18, 1911.

3 SHEETS—SHEET 2.

Fig. 2.

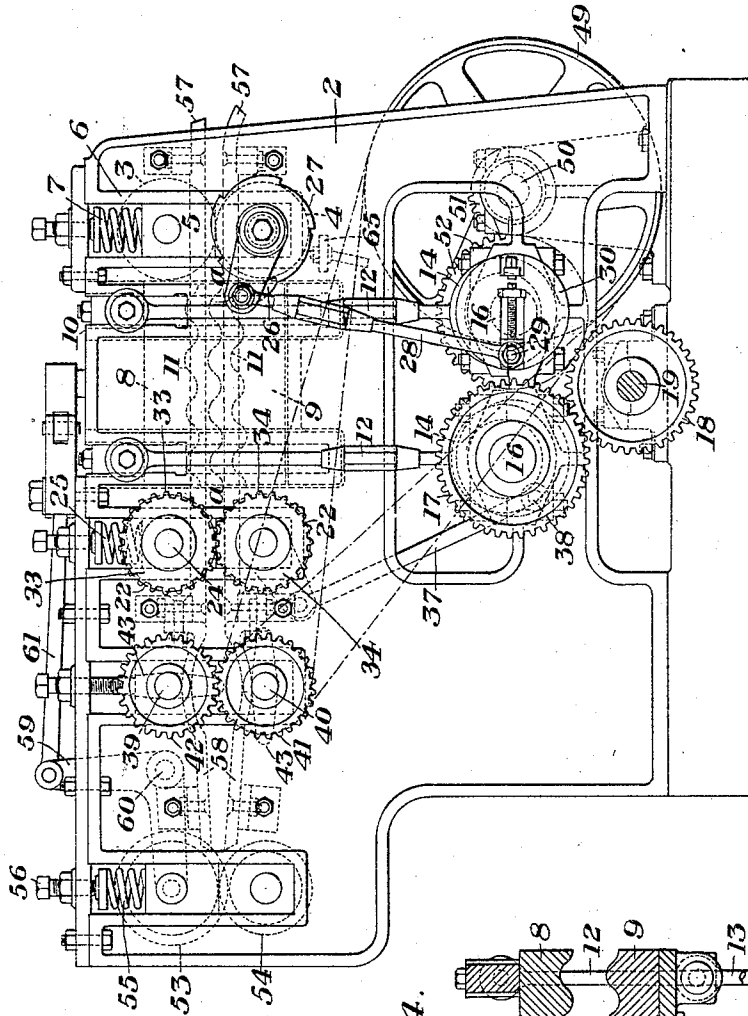
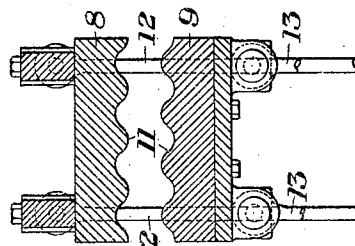

Fig. 4.



WITNESSES

R. A. Balderson,
W. U. Swartz

INVENTOR

Chas. W. Bray,
of Babcock, Blymes & Parmelee,
his Atty.

C. W. BRAY.
 APPARATUS FOR OPENING PACKS.
 APPLICATION FILED JAN. 30, 1908.

997,958.

Patented July 18, 1911.

3 SHEETS—SHEET 3.

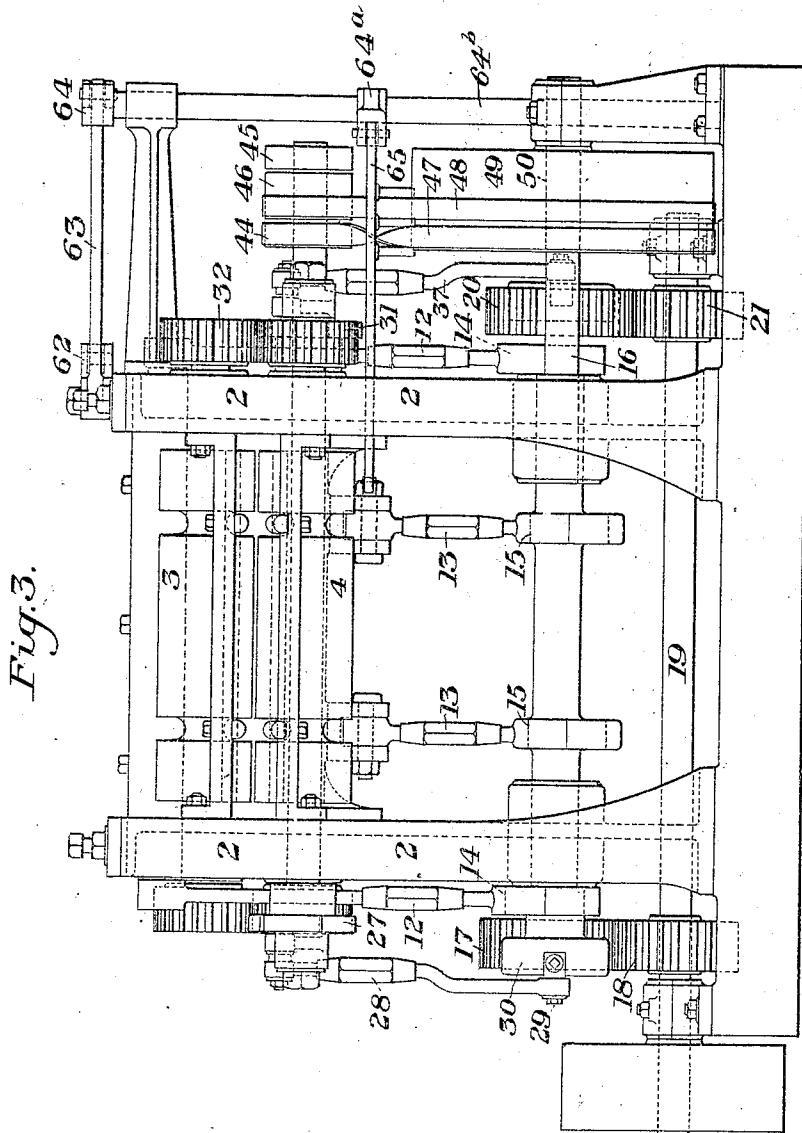

Fig. 3.

WITNESSES

R. A. Balderson
W. W. Swartz

INVENTOR

Chas. W. Bray,
by Bakewell, Dymally & Partridge,
his Attys.

UNITED STATES PATENT OFFICE.

CHARLES W. BRAY, OF PITTSBURG, PENNSYLVANIA, ASSIGNOR TO AMERICAN SHEET & TIN PLATE COMPANY, OF PITTSBURG, PENNSYLVANIA, A CORPORATION OF NEW JERSEY.
APPARATUS FOR OPENING PACKS.

997,958.

Specification of Letters Patent. Patented July 18, 1911.

Application filed January 30, 1908. Serial No. 413,403.

To all whom it may concern:

Be it known that I, CHARLES W. BRAY, of Pittsburg, Allegheny county, Pennsylvania, have invented a new and useful Apparatus for Opening Packs, of which the following is a full, clear, and exact description, reference being had to the accompanying drawings, forming part of this specification, in which—

Figure 1 is a plan view showing one embodiment of my invention; Fig. 2 is a side view of the same; Fig. 3 is an end elevation; and Fig. 4 is a detail view of the crimping die blocks.

My invention has relation to apparatus for opening sheet metal packs, and is designed to provide apparatus of simple and efficient character whereby packs may be rapidly opened.

The precise nature of my invention will be best understood by reference to the accompanying drawings in which I have shown one embodiment thereof, it being premised, however, that various changes may be made therein by those skilled in the art without departing from the spirit and scope of my invention as set forth in the appended claims.

Referring to the drawings, the numeral 2 designates the frame of the machine. Journalled in the side portions thereof at one end are a pair of feed-in rollers 3 and 4. The roller 3 is preferably carried in boxes 5 which are vertically movable in guides 6 of the frame and is held in yielding contact with the roller 4 by means of the adjustable spring 7.

8 and 9 designate a pair of vertically movable crimping or corrugating die blocks which are mounted in suitable guide-ways 10 and which are arranged to be reciprocated toward and away from each other. The working faces of these die blocks are corrugated as shown at 11, the corrugations being arranged to meet on the dotted line *a-a* (see Fig. 2). These die blocks are placed behind the feed-in rollers 3 and 4 and are reciprocated by means of link connections 12 and 13 with eccentrics 14 and 15

which are carried by shafts 16. The eccentrics 14 and links 12 actuate the upper crimping die block, while the links 13 and eccentrics 15 actuate the lower crimping die block. The two shafts 16 are journalled side by side in the lower portion of the machine, one of them being driven by a spur wheel 17 thereon which meshes with a spur wheel 18 on a driving shaft 19, while the other is driven by a spur wheel 20 which meshes with a second spur wheel 21 on the shaft 19.

22 and 22 designate a pair of flattening rollers which are journalled at the rear of the crimping die blocks, the upper roller 22 being mounted in vertically movable bearings 24 having the spring adjustment 25. The feed-in rollers 3 and 4 are driven by a step by step movement which is imparted by a pawl 26 which engages the teeth of a ratchet wheel 27 secured on the shaft of the roller 4 and actuated by a pitman connection 28 with a crank pin 29 of a crank disk 30 which is secured to the front shaft 16. The shaft of the roller 4 at its opposite end carries a pinion 31 which meshes with a pinion 32 on the shaft of the upper roller 3. The two rollers 22 and 22 are intergeared by means of the spur wheels 33 and 34. On the opposite end of the shaft of the roller 22 from the spur wheel 34 is a ratchet wheel 35 which is engaged by a pawl 36. The pawl 36 is actuated by a pitman connection 37 with a crank pin 38 of a disk on the rear shaft 16.

Journalled behind the flattening rollers 22 and 22 are a pair of shafts 39 and 40, said shafts being arranged one above the other and positively intergeared by means of the spur wheels 41 and 42. Arranged on each of these shafts are a series of beater arms 43 which are preferably in the form of flat blades which extend through the shafts so as to project at opposite sides thereof. The upper beater shaft 39 has an extension at one end as shown at 39^a in Fig. 1, and mounted on this extension are two fast pulleys 44 and 45 with an intermediate loose pulley 46.

47 and 48 are two belts for driving the

pulleys 44 and 45 and which are themselves driven by a belt pulley 49 on the short shaft 50 which is driven by a pinion 51 engaging a gear wheel 52 on the front shaft 16.

5 53 and 54 designate a pair of feed-out rollers, which, as shown in Figs. 1 and 2, are provided with interfitting circumferential ribs and grooves. The upper roller 53 is normally held in contact with the lower roller 54 by means of the springs 55 which are seated upon the vertically movable boxes in which said roller is journaled, and which are adjustable by means of the screws 56.

10 57 are guides through which the packs are fed to the feed-in rollers 3 and 4 and to the crimping die blocks.

58 are guides which carry the pack from the flattening rollers through the beater and to the feed-out rollers.

20 The rollers 3 and 4 are circumferentially grooved to receive the guides 57, as shown in Fig. 1.

Connected to an extended journal of the upper feed-out roller 53 is a bell crank lever 59 which is pivoted at 60 and whose upwardly extending arm is connected by the link 61 with one arm of a vertically pivoted bell crank lever 62. The other arm of this bell crank lever is connected by a link 63 with a belt shifting lever 64 on the shaft 64^a, this shaft also having a lever 64^a to which the belt shifting arm 65 is connected.

25 The operation of the machine is as follows:—The packs to be opened are fed into the machine through the guides 57 and the feed rollers 3 and 4. These rollers are actuated by a step by step movement through the pawl and ratchet actuating device before described so that the pack is gradually fed between the crimping die blocks and receives a succession of crimps or corrugations therein as it is fed forward and into the flattening rollers. As the die blocks will act alternately upon the high and low portions of the previous corrugations as the packs are fed forwardly, the bending action is in reverse directions, and is very effective in loosening the packs.

30 These flattening rollers are also actuated by a step by step movement and feed the pack on to the action of the beaters. The crimping or corrugating of the pack by the die blocks tends to loosen and separate them and this action is completed by the revolving beaters working against the upper and lower sheets of the pack. As the loosened packs pass out between the feed-out rollers, they raise the upper roller in its bearings, and thereby actuate the belt shifter through the connections described to shift the belts 47 and 48 of the pulleys 44, 45 and 46 on the upper beater shaft. While the packs are passing through the beaters, the crossed belt 47 is driving the pulley 44 and thereby actuating the beaters

so that they act upon the packs in the direction of movement of the packs. When, however, the pack reaches the rollers 53 and 54 and the belt shifter is operated in the manner described, the straight belt 48 is shifted on to the fast pulley 45 and the cross belt 47 is shifted on to the loose pulley 46. This reverses the action of the beaters so that they turn in a reverse direction to the movement of the packs. The purpose of this reversal of the beaters is to prevent their contacting with the ends of the sheets in the direction in which the sheets are going and thereby curling or kinking them. By causing them to act in a reverse direction upon the ends of the sheets, they exert a straightening action upon the sheets which tends to prevent any kinking or curling of their edges.

70 The advantages of my invention will be apparent to those skilled in the art. The packs can be rapidly fed into and through the machine, and under the combined action of the crimping or corrugating die blocks and of the beaters, the sheets are effectively loosened and opened.

85 I do not herein claim broadly the feature of the rotary beaters, as these are the invention of Arthur R. McArthur, as described and claimed in his Patent No. 976,895, dated Nov. 29, 1910.

What I claim is:—

1. In apparatus for opening packs, means for crimping the packs, consisting of a pair of die blocks having corrugated working faces, and means for reciprocating at least one of said blocks toward and away from the other, and mechanism for feeding a pack of metal sheets to the action of the die blocks; substantially as described.

2. In apparatus for opening packs, means for crimping the packs, consisting of a pair of die blocks having corrugated working faces, and means for reciprocating the blocks toward and away from each other, and mechanism for feeding a pack of metal sheets to the corrugating action of the blocks or dies; substantially as described.

3. In apparatus for opening packs, means for crimping the packs consisting of a pair of die blocks having corrugated working faces, and means for reciprocating the die blocks toward and away from each other, and mechanism for feeding a pack of metal sheets to the crimping action of the die blocks by a step by step movement; substantially as described.

4. In apparatus for opening packs, means for crimping or corrugating a pack, beaters arranged to act upon the crimped or corrugated pack, a pair of feed-out rollers and means actuated by the passage of the sheets through the feed-out rollers for reversing the direction of movement of the beaters; substantially as described.

70

75

80

85

90

95

100

105

110

115

120

125

130

5. In apparatus for opening packs; means for crimping the packs consisting of a pair of die blocks having corrugated working faces; means for reciprocating at least one of said die blocks toward and away from the other, means for feeding the packs to the action of the die blocks, and flattening rolls arranged behind the die blocks and ar-

ranged to act upon the packs subsequently thereto; substantially as described. 10

In testimony whereof, I have hereunto set my hand.

CHARLES W. BRAY.

Witnesses:

CLAIR KELLY,
G. C. KIMBALL.