



US00D834619S

(12) **United States Design Patent**
Stahl et al.

(10) **Patent No.:** **US D834,619 S**
(45) **Date of Patent:** **** Nov. 27, 2018**

(54) **PUMP**

(56)

References Cited

(71) Applicant: **Xylem IP Management S.a r.l.**,
Senningerberg (LU)
(72) Inventors: **Borje Stahl**, Kista (SE); **Johan**
Bratthall, Saltsjo Boo (SE); **Viktor**
Bredwad, Spanga (SE)
(73) Assignee: **XYLEM IP MANAGEMENT S.A**
R.L., Senningerberg (LU)
(**) Term: **15 Years**

U.S. PATENT DOCUMENTS

D237,011 S *	9/1975	Stroberg et al.	D15/7
D258,210 S *	2/1981	Shure	D15/7
D284,380 S *	6/1986	Berg	D15/7
D440,230 S *	4/2001	Craford	D15/7
D440,231 S *	4/2001	Craford	D15/7
D492,324 S *	6/2004	Stevens	D15/7
D677,701 S *	3/2013	Moysi	D15/7
D690,323 S *	9/2013	Burman	D15/7
D708,648 S *	7/2014	Orsini	D15/7
D740,329 S *	10/2015	Gilbert	D15/7
D800,791 S *	10/2017	Pin, III	D15/7

* cited by examiner

(21) Appl. No.: **29/602,657**

Primary Examiner — Ralf Seifert

(22) Filed: **May 2, 2017**

(74) *Attorney, Agent, or Firm* — Fox Rothschild LLP

(30) **Foreign Application Priority Data**

(57) **CLAIM**

Apr. 3, 2017 (EM) 003838135-0001

The ornamental design for pump, as shown and described.

(51) **LOC (11) Cl.** **15-02**

DESCRIPTION

(52) **U.S. Cl.**

USPC **D15/7**

(58) **Field of Classification Search**

USPC D15/7-9; D23/231, 232, 225; 417/60,
417/235, 265, 321, 355, 358, 363, 359,
417/410.1, 415-416, 405, 900, 269, 539;
60/408, 412; 184/26-37; 415/140-147;
123/495, 509; 137/565.34

CPC F02M 37/04; F02M 37/14; F04B 53/92;
F04B 1/005; F04D 13/06; F04D 29/22;
F04D 29/046; F04D 29/2266

See application file for complete search history.

1 Claim, 7 Drawing Sheets

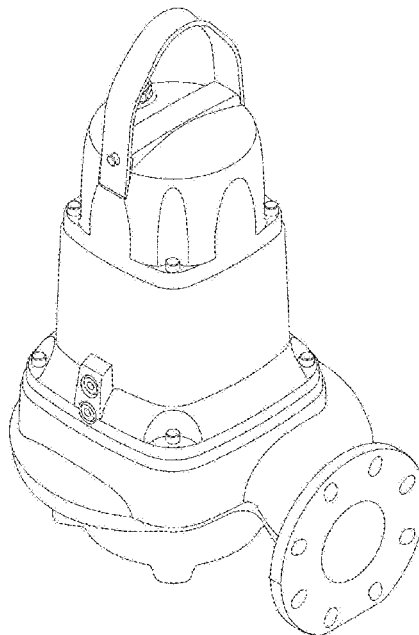

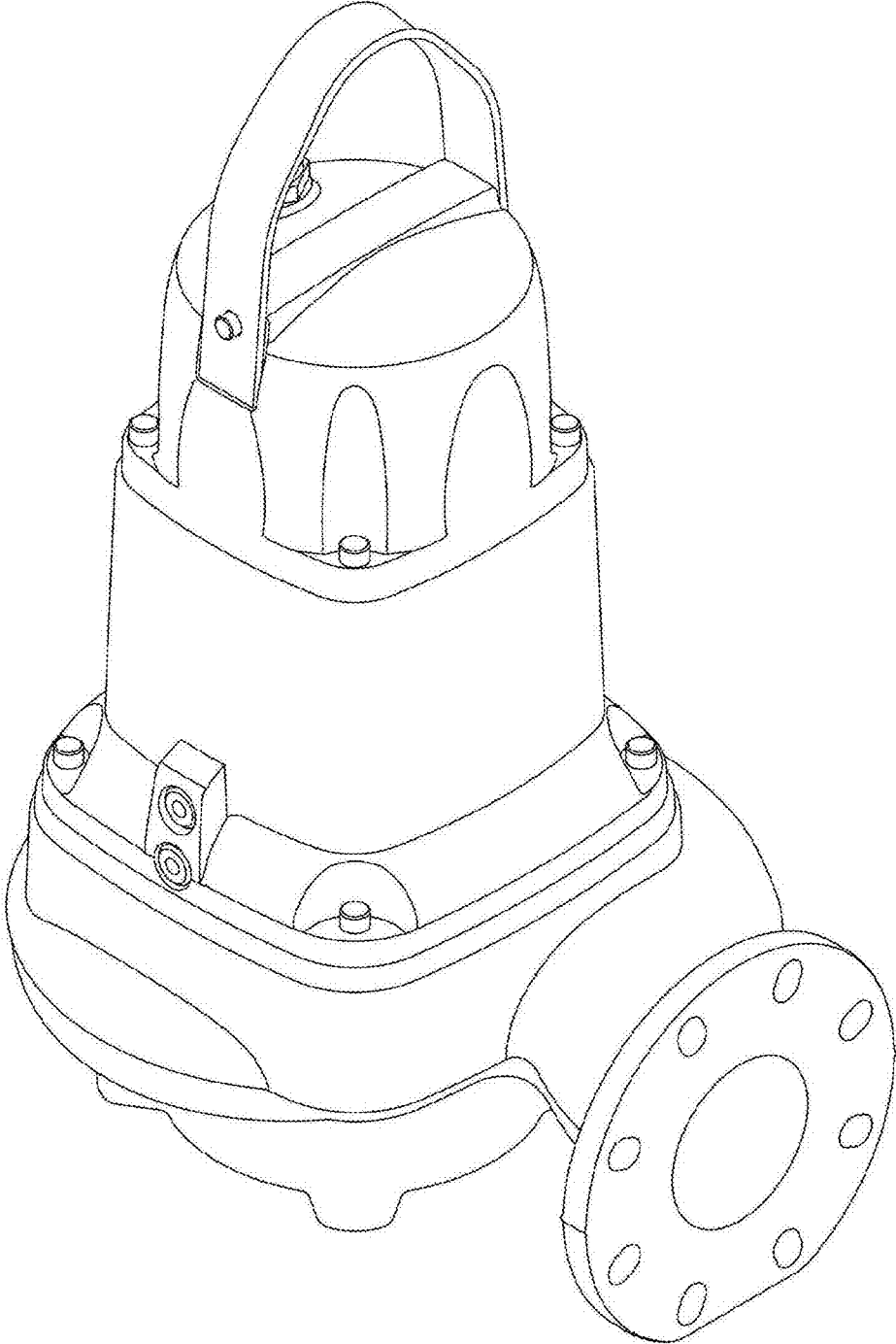

FIGURE 1

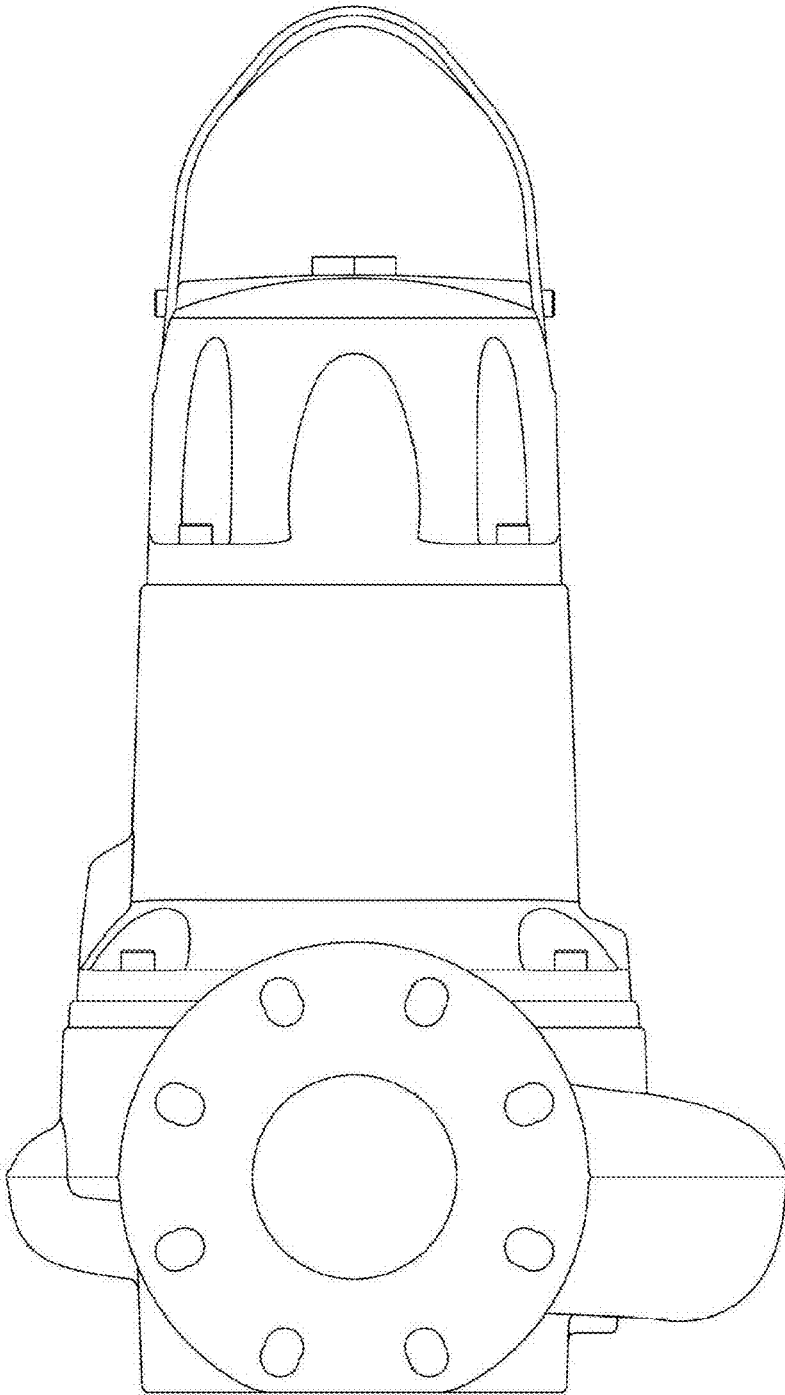

FIGURE 2

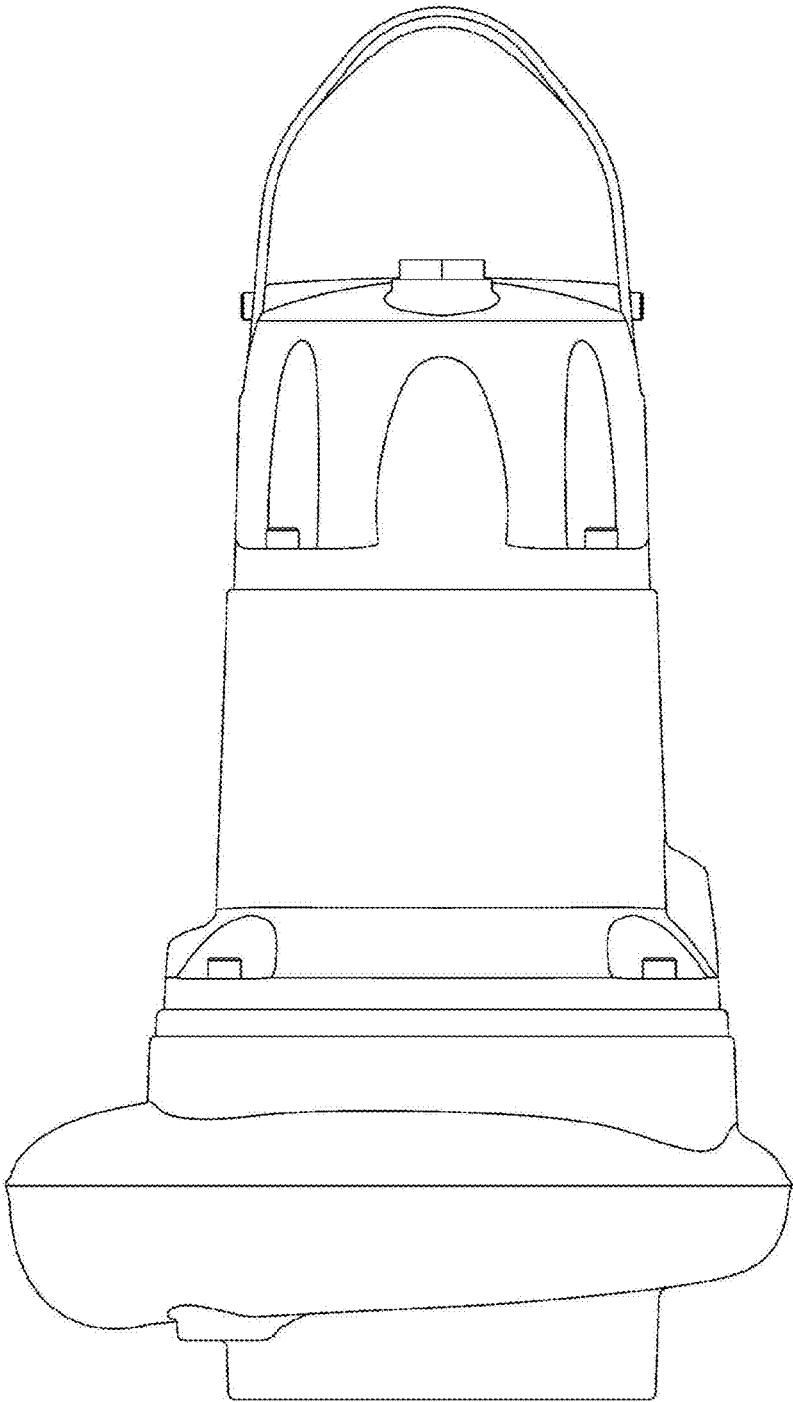

FIGURE 3

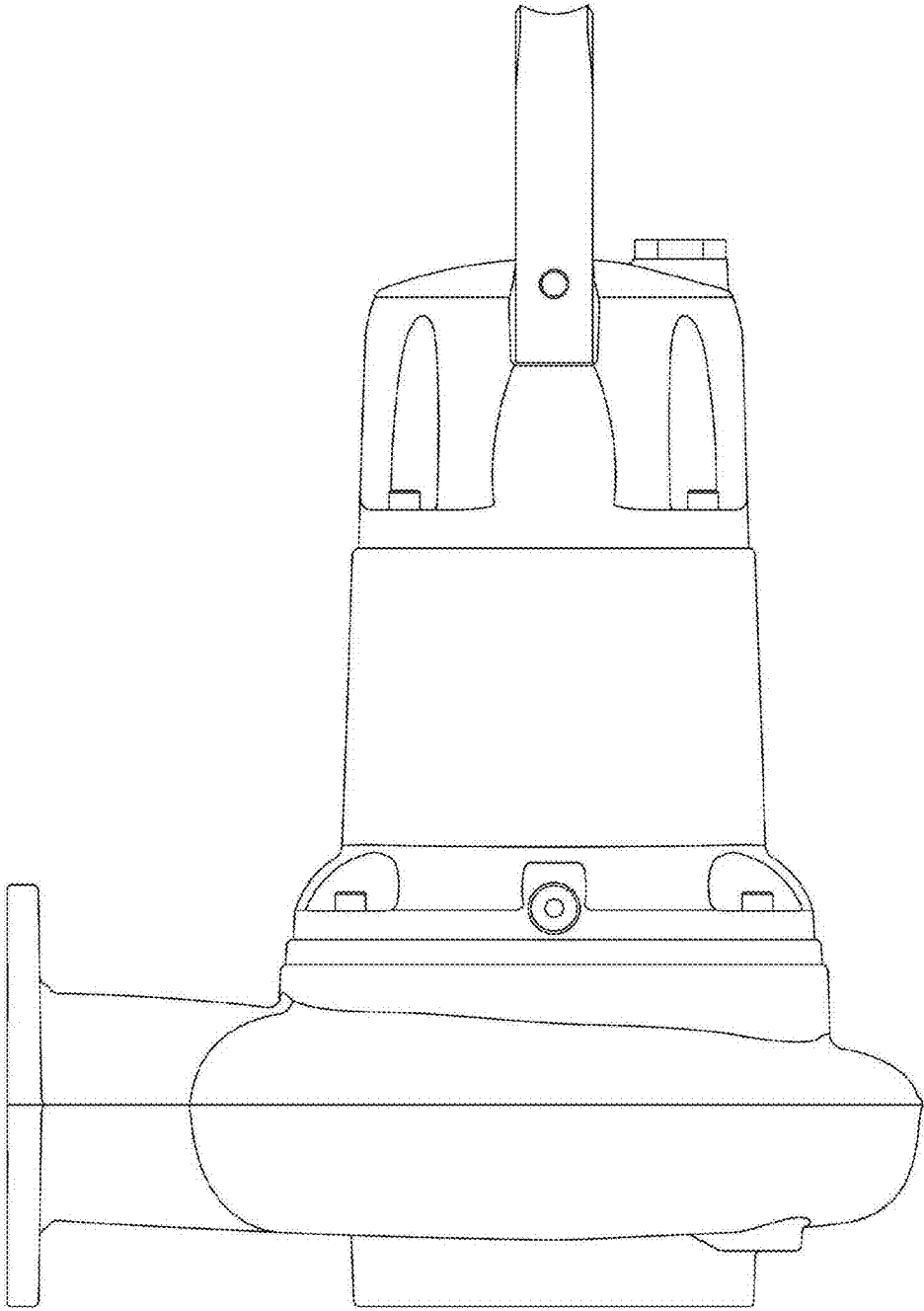

FIGURE 4

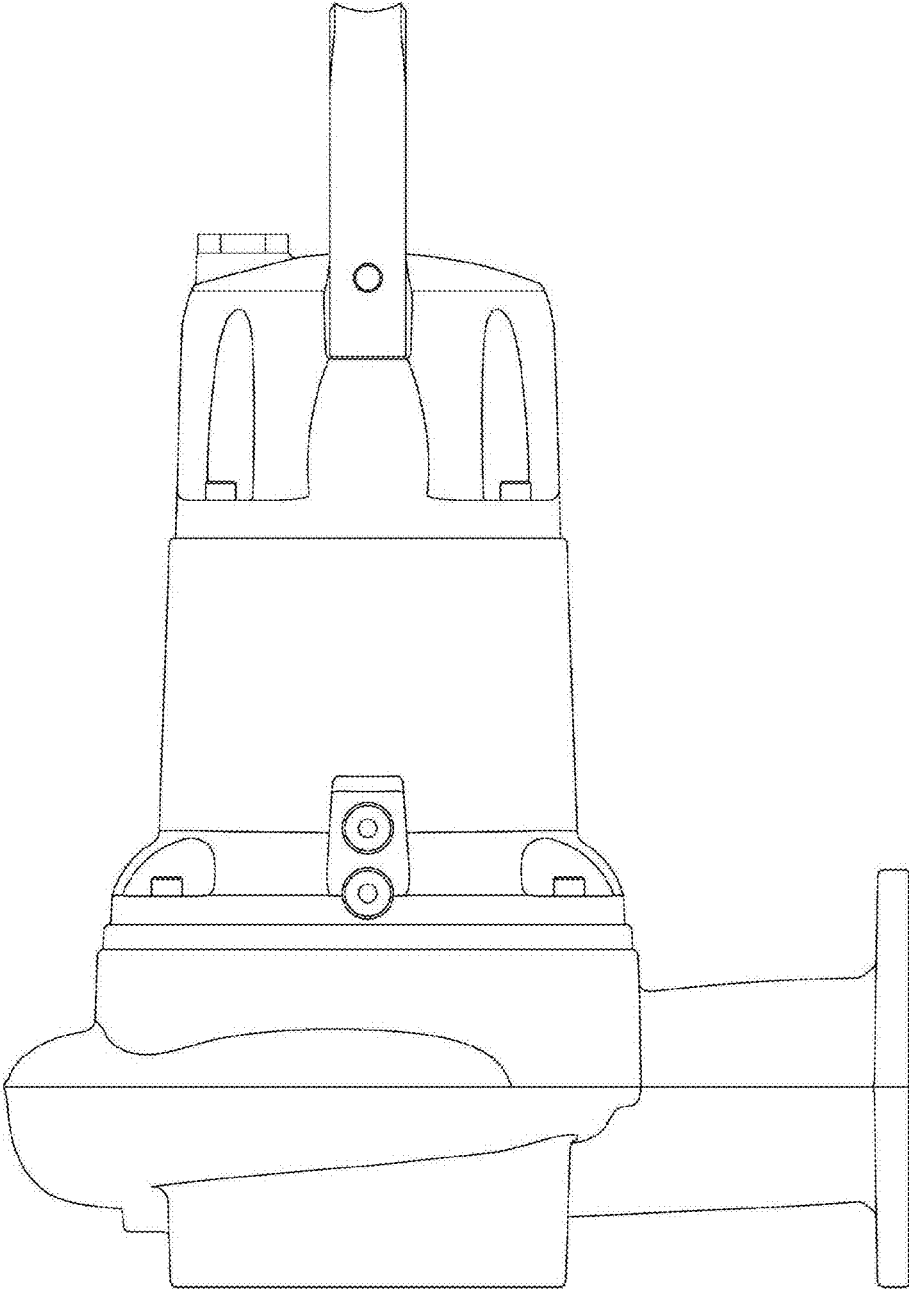

FIGURE 5

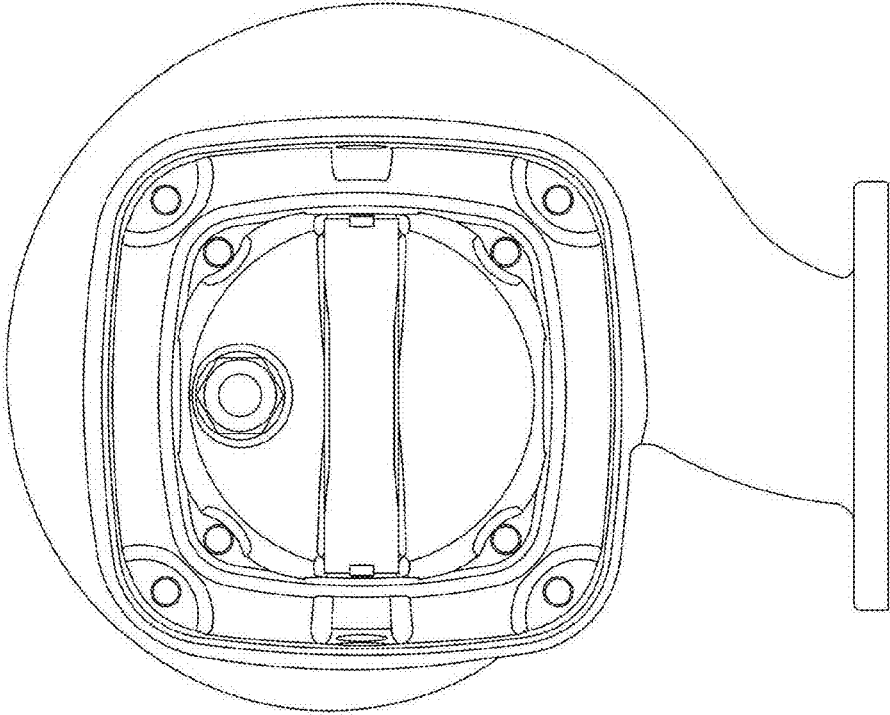

FIGURE 6

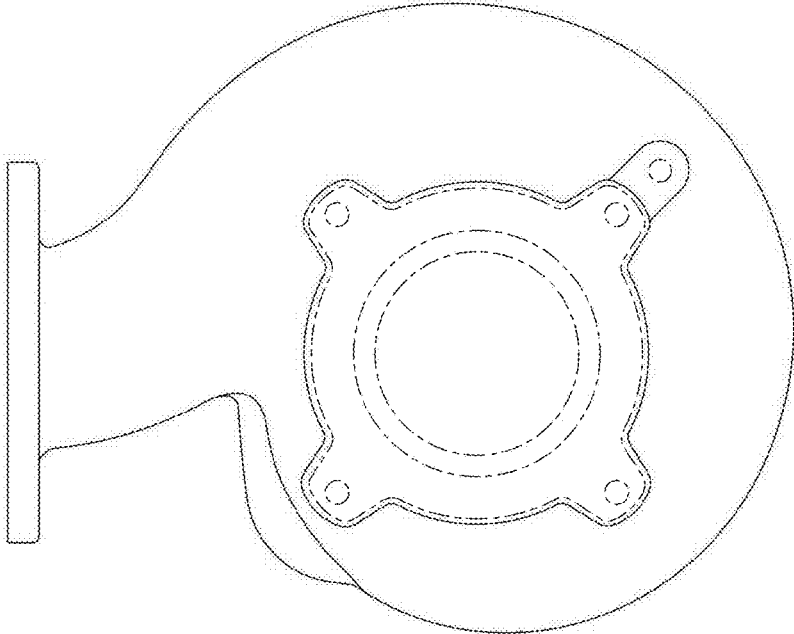

FIGURE 7