

No. 618,105.

Patented Jan. 24, 1899.

M. A. KNAPP.
TOOTH REGULATOR.

(Application filed Apr. 8, 1898.)

(No Model.)

Fig. 1.

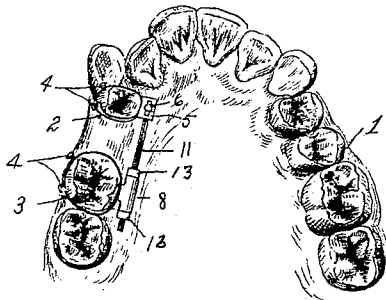

Fig. 3.

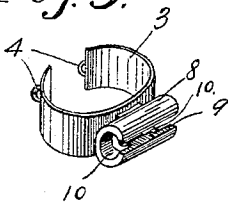

Fig. 2.

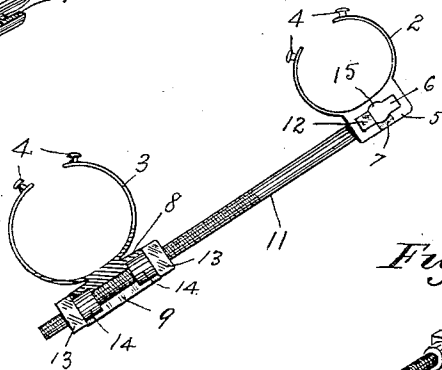

Fig. 4.

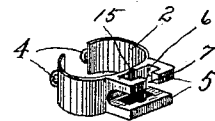

Fig. 5.

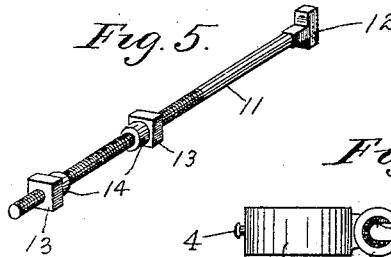
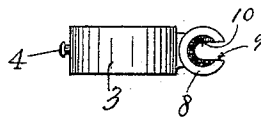

Fig. 6.



Witnesses
C. F. Kilgore
J. D. Merdiant.

Inventor
Miland A. Knapp
By his Attorney
Jas. F. Williamson

UNITED STATES PATENT OFFICE.

MILAND A. KNAPP, OF MINNEAPOLIS, MINNESOTA.

TOOTH-REGULATOR.

SPECIFICATION forming part of Letters Patent No. 618,105, dated January 24, 1899.

Application filed April 8, 1898. Serial No. 676,858. (No model.)

To all whom it may concern:

Be it known that I, MILAND A. KNAPP, a citizen of the United States, residing at Minneapolis, in the county of Hennepin and State of Minnesota, have invented certain new and useful Improvements in Devices for Regulating Teeth; and I do hereby declare the following to be a full, clear, and exact description of the invention, such as will enable others skilled in the art to which it appertains to make and use the same.

My invention relates to teeth regulating or alining devices, and has for its object to simplify and improve the construction and to accomplish certain results hereinafter specifically noted.

My present invention is in the nature of a modification or improvement of the device disclosed and claimed in my prior patent, No. 579,582, issued of date March 24, 1898, entitled "Device for regulating teeth."

The said invention consists of the novel devices and combinations of devices hereinafter described, and defined in the claims.

The preferred form of the invention is illustrated in the accompanying drawings, wherein like characters indicate like parts throughout the several views.

Figure 1 is a plan view of a part of the human jaw, showing my improved regulating device applied in working position. Fig. 2 is a plan view, with some parts sectioned, showing, on an enlarged scale, the regulating device illustrated in Fig. 1. Fig. 3 is a detail view in perspective showing one of the tooth-bands employed in the device. Fig. 4 is a detail view in perspective showing another of the tooth-bands removed from working position. Fig. 5 is a perspective view of the tension-rod, and Fig. 6 is a side elevation of the tooth-band shown in Fig. 3.

1 indicates the human jaw. (Shown only in Fig. 1.)

2 and 3 indicate a pair of tooth-bands, which, as shown, are of the form claimed in my said prior application, the same being provided at their split ends with headed studs or projections 4, over which wire thread may be wound to secure the bands to the teeth. The band 2 is provided with a pair of vertically-spaced lugs or flanges 5, which are perforated by elongated or rectangular seats 6, that are lo-

ated in vertical line with each other. The upper member of the lugs 5 is cut away or slotted at 7, so as to form an opening into the central portion of the seat 6 thereof. The band 3 is provided with a tubular rod seat or lug 8, which is attached thereto at its central portion by means of solder or otherwise. The bore or passage through this tubular section 8 is of approximately the same diameter as the tension-rod, which is to be described, and a slot 9 of the width of said bore is cut longitudinally through the outer wall of the tube. The passage or bore through the center of the tube 8 is enlarged or counterbored at its extremities to form sockets 10.

11 indicates the tension-rod, which is screw-threaded at one end and provided with a T-shaped head 12 at its other end, the prongs of which are angular, or, as shown, approximately square in cross-section, so as to fit snugly in the extremities of the slots or seats 6 of the lugs 5.

13 indicates nuts which are provided with projecting sleeves or collars 14 and work with screw-threaded engagement on the tension-rod 11.

In applying this device in working position, as illustrated in Fig. 1, the tooth-bands are secured in the manner already described. The T-shaped head 12 may be inserted within the seats 6 when the rod is turned in line with the slot 7 by forcing said rod downward through said slot 7, and then, after having given said rod a quarter-turn into line with said seats 6, said T-head 12 may be drawn into and tightly held against rotation by said seats. To permit the rod to be turned between the lugs 5, as just described, said lug-seats are slightly enlarged at their central portions, as illustrated at 15. If the rod 11 is drawn upon, the T-head thereof will be forced into certain extremities of the seats 6, and if pushed upon it will be forced into other extremities of the said seats. In either case the rod 11 will be connected to the band 2 and lugs 5 in such manner that the said band cannot possibly turn or rotate with respect to said rod. This is very important in many cases, as it prevents the tooth from being rotated as it is pushed or drawn into line or into proper position. The tension-rod 11 is given some play or clearance between the

lugs 5 of the band 2. Hence when the tooth to which the band 2 is applied is drawn or pushed by the tension-rod 11 it cannot possibly rotate, but is, nevertheless, free to tilt, inasmuch as the T-head 12 is free for angular movement longitudinally of the seats 6.

The screw-threaded end of the tension-rod 11 may be very easily and quickly attached to or disconnected from the tube 8 of the band 3 simply by tightening or loosening the nuts 13, so as to force their sleeve portions 14 into or out of the countersunk seats or sockets 10, it being understood, of course, that the rod itself is inserted laterally through the slot 9, as previously indicated. The rod 11 is in this manner connected to the cooperating band 2, so that said band can neither tilt nor rotate with respect thereto. As is obvious, when a tooth is used as an anchor or base of resistance in pulling another tooth it is of the utmost importance that it should neither be turned on its axis nor tilted, while the tooth which is to be moved must be permitted to tilt.

It is very important to note that the tension-rod 11 may be disconnected and removed from the tooth-bands or applied in working position thereto without giving the same any more endwise movement than is necessary to bring the T-head 12 to or from the central position at the enlarged portion 15.

It will of course be understood that alterations in the specific details of construction above described may be made within the scope of my invention.

What I claim, and desire to secure by Letters Patent of the United States, is as follows:

1. In a device for regulating teeth, a joint between two parts thereof, consisting of an angular seat in one of said parts and an angular projection in the other of said parts,

detachably engageable with said angular seat, whereby said parts are held against angular movement with respect to each other in a plane cutting the axis of said joint, substantially as described. 45

2. In a device for regulating teeth, a joint or connection between two parts of the same, consisting of an angular seat formed in one of said parts and an angular head on the other of said parts, which angular head fits said angular seat snugly in one direction and loosely in the other, whereby said connected parts are held against rotation with respect to each other, but are permitted to tilt, substantially as described. 55

3. In a device for regulating teeth, a joint or connection between two parts of the device, consisting of a bifurcated head on one of said parts, provided with perforations or seats, and a slot opening into one of said perforations or seats, and a T-shaped head on the other of said parts to be coupled, for cooperation with said seats or slots, which T-head, when seated in said seats, is fixed against pivotal movement with respect to said bifurcated head, substantially as described. 65

4. The combination with a tension-rod and a pair of nuts with projecting collars, working thereon, of a tooth-band with projecting part, cut away to receive said rod, laterally and formed with sockets or seats adapted to receive the projecting collars of said nuts, by endwise movement only, substantially as described. 75

In testimony whereof I affix my signature in presence of two witnesses.

MILAND A. KNAPP.

Witnesses:

LILLIAN C. ELMORE,
F. D. MERCHANT.