

E. Von Jensen,

Lubricator.

No. 107,739.

Patented Sep. 27. 1870.

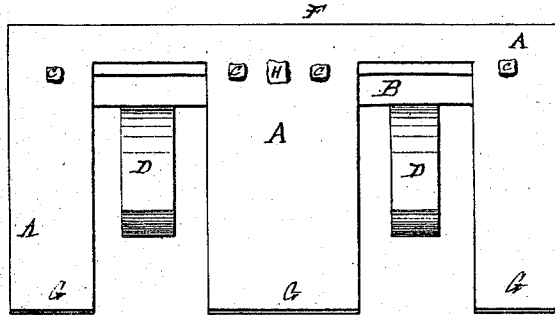

Fig. 1

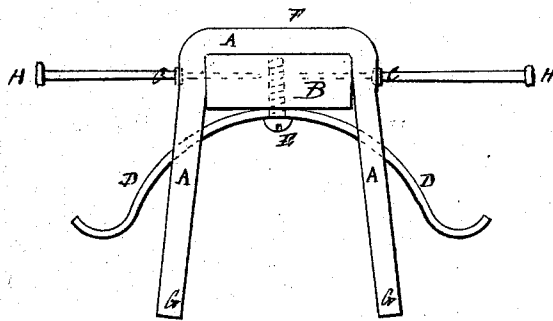

Fig. 2

Witnesses

Wm. Smith

David B. Smith

Inventor

Ernest von Jensen

United States Patent Office.

ERNEST VON JEINSEN, OF SAN FRANCISCO, CALIFORNIA.

Letters Patent No. 107,739, dated September 27, 1870.

IMPROVEMENT IN LUBRICATORS.

The Schedule referred to in these Letters Patent and making part of the same.

To all whom it may concern:

Be it known that I, ERNEST VON JEINSEN, of the city and county of San Francisco, State of California, have invented an "Improved Self-Acting Lubricator for Axle-Boxes;" and I do hereby declare that the following is a full, clear, and exact description of the same, reference being had to the accompanying drawing and to the letters marked thereon.

The object of my invention is to provide an improved device for economically and effectually lubricating the journals or wearing surfaces of car-axles, or other axles or shafts that carry the weight of the car or machinery upon their upper surfaces, and have no bearing below.

My present invention relates to additional improvements in that class of lubricators shown in my Letters Patent dated July 5, 1870, and which convey the oil by capillary attraction from a suitable reservoir, chamber, or recess, to the journals or wearing-surface of the machinery, and distribute it upon every part of said surface by means of strips or sheets of felt, or other capillary substance, so arranged that while only just sufficient of the conducting material is employed to answer the purpose required, every part of the journal or wearing-surface will be brought repeatedly in contact with the said capillary sheets or strips during the revolutions of the journal or the movements of the machinery, said sheets, or strips, or wicks, acting like a brush in distributing the lubricating oil, and, like the wick of a lamp, in conveying said oil to the distributing-surface or brush.

This invention consists of a piece of wood, or other suitable material, a little shorter than the journal to which it is to be applied, over which is bent a sheet of felt, or other capillary substance, properly secured by nails, or otherwise, to the wood, and extending down each side to the oil contained in the reservoir below, the upper surface of the felt being pressed gently against the lower surface of the journals by springs attached to the under side of the wood, said springs resting upon and reacting from the bottom of the oil-reservoir.

In the drawing—

Figure 1 is a side elevation of a device embodying my invention.

Figure 2 is an end view of the same.

Each part is distinguished by the same letter whenever it appears in the several drawings.

A is a piece of thick felt, cut from a sheet of that material; but instead of felt any suitable substance may be used that possesses the property of absorbing a liquid, and conducting it by means of capillary attraction.

B is a rectangular piece of wood, a little shorter than the length of the journal, to the under side of which my invention is to be applied. I prefer wood because of the facility with which it is obtained and

fashioned into the required form, and on account of the facility with which the felt may be secured to it; but any other suitable material may be used.

C are the nails by which the felt is attached to the wood.

D are springs, secured by screws E to the under side of the wood.

It is obvious that instead of employing springs, constructed as shown in the drawing, spiral springs may be used, and where there is but little room below the journal, I prefer to use one or more spiral springs, formed like a bed-spring, in which the radii of the coils decrease from below upward, or from above and below toward the center of its height in such a manner that, when the spring is compressed, one coil will close or pass within the other, and occupy much less room vertically than other kinds of springs.

The height of the device should be such that, when placed under a journal for use, the upper surface F of the felt should be caused to slightly press the under side of the journal by the action of the springs D reacting from the bottom of the oil-reservoir, and it is evident that when so placed, the ends G of the felt would absorb the oil, and convey it from the reservoir to the surface F to be distributed, as with a brush, upon the surface of the journal.

H are guides, projecting from each side of the lubricator, formed by driving nails into the wood.

For a railroad-car axle-box, the outer extremities of the guides, by coming in contact with the sides of the casing or box, will retain the lubricator in its proper position under the journal. Either one or two pairs of guides, H, may be used.

It is obvious that, instead of nails, the guides H may be formed in any convenient manner, with transverse pieces of wood or metal, but I prefer the use of common nails, as shown, on account of simplicity and the facility of application.

Having thus described my invention,

What I claim, and desire to secure by Letters Patent, is—

1. The lubricating device herein described, consisting of the springs D, the piece of wood B, and the felt A, or the equivalent of these parts, when secured together, and arranged to operate in a manner substantially as and for the purpose herein described and set forth.

2. The lubricating device herein described, when provided with guides H, or their equivalents, as described.

In testimony whereof I have hereunto set my hand and seal.

ERNEST VON JEINSEN. [L. s.]

Witnesses:

C. W. M. SMITH,
DAVID R. SMITH.