

(19)



Europäisches Patentamt
European Patent Office
Office européen des brevets



(11)

EP 0 555 193 B1

(12)

EUROPEAN PATENT SPECIFICATION

(45) Date of publication and mention
of the grant of the patent:
12.06.1996 Bulletin 1996/24

(51) Int Cl.⁶: **F21S 3/14, F21V 21/02,
E04B 9/00**

(21) Application number: **93850020.4**

(22) Date of filing: **02.02.1993**

(54) **Lighting device**

Beleuchtungsvorrichtung

Dispositif d'éclairage

(84) Designated Contracting States:
**AT BE CH DE DK ES FR GB GR IE IT LI LU MC NL
PT SE**

(30) Priority: **03.02.1992 SE 9200292**

(43) Date of publication of application:
11.08.1993 Bulletin 1993/32

(73) Proprietor: **ECOPHON Aktiebolag
S-260 61 Hyllinge (SE)**

(72) Inventor: **Olsson, Ulf
S-260 61 Hyllinge (SE)**

(74) Representative: **Henningsson, Gunnar et al
AWAPATENT AB,
Box 45086
S-104 30 Stockholm (SE)**

(56) References cited:
**EP-A- 0 306 463 US-A- 3 064 121
US-A- 3 202 814 US-A- 4 569 004
US-A- 4 725 931**

EP 0 555 193 B1

Note: Within nine months from the publication of the mention of the grant of the European patent, any person may give notice to the European Patent Office of opposition to the European patent granted. Notice of opposition shall be filed in a written reasoned statement. It shall not be deemed to have been filed until the opposition fee has been paid. (Art. 99(1) European Patent Convention).

DescriptionTechnical field

The present invention relates to a device for indirect lighting in conjunction with a suspended ceiling structure which includes suspended sections as a support and panels supported thereon, the device comprising channel means disposed such that an out-of-sight or shielded, longitudinally extending channel is formed which is open in one direction for the emission of light, and in which longitudinally extending light fittings are disposed for the emission of light through the opening in said channel towards adjacent roof or wall portions to provide indirect lighting. In particular, the suspended ceiling structure has a transition in levels where said channel means is provided.

Background art

As a rule, prior art lighting devices of the abovementioned type have separate channel members attached to a portion of the wall some distance from the suspended ceiling which occasionally causes installation problems. Fittings, typically fluorescent light fittings, are mounted in line in the longitudinal direction of the channel using various types of special attachments. The respective ends of the lights thus end up being separated from each other by not insubstantial distances which has been found to give rise to shadow effects and/or uneven light distribution which, in many cases, can be regarded as disturbing.

US-A-4,569,004 discloses a device for indirect lighting in conjunction with a suspended ceiling structure. The device comprises a channel means having a channel with longitudinally extending light fittings and with an upwardly directed channel opening for the emission of light. The channel means comprises a frame structure carrying ceiling material and forms an integrated transition between two ceiling levels.

US-A-3,202,814 mentions that in order to overcome uneven lighting from tubular lamps provided in a channel means, the lamps can be arranged in a staggered configuration with their ends overlapping.

Object of the invention

The object of the invention is to provide an improved lighting device of the type described in the introduction whereby indirect lighting adjacent the transition between levels in a suspended ceiling can be provided in a simple and effective manner, even in light wells, and whereby the above drawbacks can be avoided. At the same time additional benefits can be attained, in the form of integration of the lighting into the suspended ceiling structure itself, increased flexibility and better capacity for variation when it comes to setting up the light distribution.

Summary of the invention

The abovementioned objects are attained by a device having the features defined in the accompanying patent claims.

Accordingly, the lighting device of the invention is essentially distinguished in that said channel means comprises a section integrated into the suspended ceiling structure and employed for connecting the component ceiling panels in the transition between levels of the suspended ceiling. Furthermore, the light fittings are disposed overlapping each other in the longitudinal direction of the channel such that their fields of illumination overlap each other. It thereby becomes possible to control and vary the overall distribution of light in a simple and effective manner, in that varying degrees of overlap between fittings, varying relative positions of the channel and fittings etc can be provided, as will be further illustrated below.

Although the light fittings can be permanently mounted in the channel, it is advantageous in the practise of the invention if the light fittings are individually translatablely adjustable in the longitudinal direction of the channel. It will be appreciated that the mutual positions and degree of overlap of the fittings can thus be simply adjusted or altered and at the same time the task of wiring up and connecting is facilitated in many cases. Fittings which are to sit at an end of the channel, a position which in many cases is not within easy reach for mounting work, can be simply moved on to their final position after being initially placed in the channel and wired up at a place where this can be done without obstruction or other difficulties.

Arranging the light fittings in at least two rows parallel to the longitudinal direction of the channel has been found to be advantageous. In this arrangement, it is advantageous to dispose the light fittings on respective associated mounting units which are adapted for separate attachment in the channel.

In a preferred embodiment, the light fittings in a first row are disposed on mounting units which are secured to, or supported by, a first "side" wall (in the broad sense) or the "bottom" (in the broad sense) of the channel, while a second row of light fittings are disposed on mounting units which are secured to, or supported by a second, opposed "wall" of the channel, broadly speaking, and the channel bottom. It will be apparent that using separate, not necessarily similarly shaped, mounting units gives the possibility of various configurations as regards the position of the fittings relative to each other and relative to the channel.

An advantageous embodiment has mounting units of an angled strip configuration with a first part extending generally crosswise relative to the channel and a second part extending generally depthwise in the channel. In this arrangement, the terminating edge portion of said second part of the mounting unit can be guided in a longitudinally extending groove adjacent the channel bot-

tom while the terminating edge portion of said first part of the mounting unit can be secured by a securing means which, at a desired position, engages a longitudinally extending groove in the respective side wall of the channel, said second parts of the mounting units preferably bearing against each other where they overlap and preferably being guided in the same groove in the channel bottom. It should be appreciated that the depthwise location of a fitting in place on a mounting unit in the channel can be easily adjusted, e.g. by adjusting the height of a said second part of a mounting unit, without needing to consider neighbouring mounting units.

The invention will now be described in greater detail with the help of an exemplary embodiment and with reference to the accompanying drawings.

Brief description of the drawings

Fig. 1 is a schematic, side view of an embodiment of a device according to the invention.

Fig. 2 is a schematic, perspective view, partly in section, of the device of Fig. 1 in which certain parts have been omitted for the sake of clarity.

Description of the embodiment

Figs. 1 and 2 illustrate, by way of example, a device in accordance with the invention for the indirect suspended ceiling lighting of a transition in ceiling levels, in the form of a sloping ceiling panel 1 which forms a continuation of a lower lying horizontal ceiling panel 3. Panels 1 and 3 are only schematically indicated as they can be of conventional design. Ceiling panels 1 and 3 are supported by a section 5 which is of unitary fabrication and is integrated into the suspended ceiling structure. The section 5 is suspended in a conventional fashion with an inverted, capital T-shaped suspending element 7 which is only schematically indicated because it is of no significance to the invention, either. Towards its bottom, the section 5 has a horizontal flange 6 for supporting the horizontal ceiling panel 3 and towards its top has a projecting receiving portion 8 for the sloping ceiling panel 1, which in the illustrated embodiment forms an angle of about 45° with the horizontal. The flange 6 and receiving portion 8 project outwardly in generally opposite directions.

The section 5 defines a channel 9 having an upwardly directed opening which provides the desired release profile from the, in this case fluorescent, light fittings 11, 12, mounted in the channel 9. The section 5 has a generally concave configuration and can be said to have two opposed channel side walls 13, 14 and a channel bottom 15. Side wall 13 is essentially a freely projecting, upwardly curving section portion while side wall 14 is essentially a vertical downward continuation of the suspending element 7. Towards the top and bottom of side wall 14 are portions 8 and 6 for respectively supporting ceiling panels 1 and 3.

A number of fluorescent light fittings 11, 12 are mounted in two parallel rows within the channel 9 of the section 5 in such a fashion that successive fittings lie in alternate rows and that adjacent fittings overlap each other, as illustrated in Fig. 2. An overlap of the order of 10 - 20 cm, typically around 15 cm has been found suitable.

Each fitting is mounted on a separate mounting unit 21 and includes two fluorescent light holders 23, 24 secured at respective ends on the upper side of the corresponding mounting unit. For the sake of clarity, the fluorescent lights themselves have been omitted in Fig. 2. Advantageously, other light fitting components can be mounted on the underside of the mounting unit 21.

In the illustrated embodiment, the mounting units 21 are similar for all the fittings, although the mounting units are oppositely arranged in either row.

The mounting units 21 are formed from a right-angled strip having a first (in this case horizontal) plane 25 and a second (in this case vertical) plane 26. The holders 23, 24 are secured to the first part 25 adjacent the transition to the second part 26. The free edge portion 27 of the first part 25 is angled upward in the opposite direction from the second part 26 and functions as a support and securing portion as does the adjoining border portion of said first part 25. The portions in question are equipped with holes 29, 30 for screw fasteners 31 and 32 respectively which can be screwed securely into respective cooperating longitudinally extending grooves 33 and 35 disposed adjacent the respective side walls 14, 13 of the channel.

Thus at side wall 14 of the channel the hole 29 in the upwardly angled portion 27 is used for the securing of the mounting unit 21. Additionally, associated with groove 33 is a projecting, longitudinally extending flange 37 upon which the bordering area of the first part 25 is supported.

At side wall 13 of the channel, the hole 30 in said bordering region of part 25 is used for the securing of the mounting unit. In this case, the groove 35 runs in a projection 39 which provides a similar sort of support as the flange 37. Additional support can be provided by the cooperation of the angled up portion 27 with wall 13 directly or with a projection therefrom.

The second parts 26 of the mounting units bear against each other where they overlap. It should be appreciated that this in itself provides a stabilizing effect. Additionally, the lower free edge regions of the second parts 26 are guided and supported in a groove 41 in the bottom part 15 of the section 5.

It will be appreciated that the mounting units 21 can easily be given another form within the context of the selected mounting technique. For example, the height of the second part 26 can be altered and thus the location of the fitting in the channel 9 will be changed. In one and the same channel, it is possible to use differently shaped mounting units which give the fittings different relative positions, e.g. if an especially complex light dis-

tribution is desired.

As will be apparent without further elaboration, the mounting units 21 with fitting components mounted and electrically ready-connected can be simply placed in the channel 9 and electrically connected together, preferably in rows. By so doing, wiring up etc is facilitated by the access to the spaces under or within the mounting units in that the fittings in their respective rows end up being separated by considerable open spaces and by the general mobility of the mounting units. To finish up, the mounting units with fittings connected can be adjusted to the desired position and desired light distribution and securely screwed. Finally, because the section 5 is integrated into the suspended ceiling structure, connection of the fittings to the mains is facilitated.

Claims

1. A device for indirect lighting in conjunction with a suspended ceiling structure which includes suspended sections and panel means (1, 3) supported thereon, the device comprising channel means disposed such that an out-of-sight, longitudinally extending channel (9) is formed which has an upwardly directed channel opening for the emission of light and in which longitudinally extending light fittings (11, 12) are disposed for the emission of light through said opening towards adjacent roof or wall portions thereby to provide indirect lighting, said channel means being integrated into the suspended ceiling structure so as to define a transition in levels of the suspended ceiling, characterized in that said channel means comprises a section (5), the section being arranged to support an end of a horizontal ceiling panel means (3) at its foot and to support a lower end of a sloping ceiling panel means (1) overhead, thereby providing said transition, the section (5) being suspended in a suspending element (7) of the suspended ceiling structure, and in that light fittings (11, 12) are disposed, overlapping each other, longitudinally along the channel (9) of the section (5), so that the fields of illumination from the light fittings overlap each other thereby avoiding shadow effects and/or uneven light distribution in the indirect lighting.
2. A device according to claim 1, characterized in that the light fittings (11, 12) are translatably adjustable in the longitudinal direction of the channel (9).
3. A device according to claim 1 or 2, characterized in that the light fittings (11, 12) are disposed in at least two rows parallel with the longitudinal direction of the channel (9).
4. A device according to claim 3, characterized in that the light fittings (11, 12) in the respective rows are

disposed on respective, associated mounting units (21).

5. A device according to claim 4, characterized in that the light fittings (11) in a first row are disposed on mounting units (21) which are secured to or supported by a first side wall (14) of the channel and a channel bottom (15), and in that the light fittings (12) in a second row are disposed on mounting units (22) which are secured to or supported by a second, opposed side wall (13) of the channel and the channel bottom (15).
6. A device according to claim 5, characterized in that the mounting units (22) have an angled strip configuration having a first part (25) which extends generally crosswise relative to the channel (9) and a second part (26) which extends generally depthwise in the channel (9).
7. A device according to claim 6, characterized in that the terminating edge portions of the second parts (26) of the mounting units (22) are guided in a longitudinally extending groove (41) adjacent the channel bottom (15) and that the terminating edge portions of said first parts (25) of the mounting units (22) are secured via securing means (31 & 32, respectively) which engage a longitudinally extending groove (33 & 35, respectively) adjacent the respective side wall (14 & 13, respectively) of the channel, said second parts (26) of the mounting units preferably bearing against each other where they overlap and preferably being guided in the same groove (41) adjacent the channel bottom.
8. A device according to any preceding claim, characterized in that the section (5) has a first channel side wall (14) which essentially forms a vertical downward continuation of a suspending element (7) for the section and a second channel side wall (13) in the form of an essentially freely projecting, upwardly curving section portion.

Patentansprüche

1. Vorrichtung zur indirekten Beleuchtung in Verbindung mit einer aufgehängten Deckenstruktur, die aufgehängte Abschnitte und Plattenmittel (1, 3) umfaßt, die hieran getragen sind, wobei die Vorrichtung Kanalmittel aufweist, die so angeordnet sind, daß ein außer Sicht liegender, sich in Längsrichtung erstreckender Kanal (9) gebildet ist, der eine nach oben gerichtete Kanalöffnung für das Emittieren von Licht aufweist und in dem sich in Längsrichtung erstreckende Licht-Ausstattungsgegenstände (11, 12) zum Emittieren von Licht durch die genannte Öffnung zur benachbarten Wand oder zu benach-

- barten Wandabschnitten angeordnet sind, um hierdurch für eine indirekte Beleuchtung zu sorgen, wobei die genannten Kanalmittel in die aufgehängte Dachstruktur so integriert sind, daß ein Übergang in dem Niveau der aufgehängten Decke gebildet ist, dadurch **gekennzeichnet**, daß die genannten Kanalmittel einen Abschnitt (5) aufweisen, der Abschnitt so angeordnet ist, daß er ein Ende einer horizontalen Deckenplatteneinrichtung (3) an seinem Fuß abstützt und ein unteres Ende einer geneigten Deckenplatteneinrichtung (1) über Kopf abstützt, wodurch er den genannten Übergang herstellt, der Abschnitt (5) in einem Aufhängeelement (7) der aufgehängten Deckenstruktur aufgehängt ist, und daß Licht-Ausstattungsgegenstände (11, 12) einander überdeckend in Längsrichtung des Kanals (9) des Abschnitts (5) so angeordnet sind, daß die Beleuchtungsfelder aus den Licht-Ausstattungsgegenständen einander überdecken, wodurch Schattenwirkungen und/oder eine ungleichmäßige Lichtverteilung in der indirekten Beleuchtung vermieden ist.
2. Vorrichtung nach Anspruch 1, dadurch **gekennzeichnet**, daß die Licht-Ausstattungsgegenstände (11, 12) in Längsrichtung des Kanals (9) versetzbar einstellbar sind.
3. Vorrichtung nach Anspruch 1 oder 2, dadurch **gekennzeichnet**, daß die Licht-Ausstattungsgegenstände (11, 12) in mindestens zwei Reihen parallel zur Längsrichtung des Kanals (9) angeordnet sind.
4. Vorrichtung nach Anspruch 3, dadurch **gekennzeichnet**, daß die Licht-Ausstattungsgegenstände (11, 12) in den jeweiligen Reihen an jeweiligen, zugeordneten Montageeinheiten (21) angeordnet sind.
5. Vorrichtung nach Anspruch 4, dadurch **gekennzeichnet**, daß die Licht-Ausstattungsgegenstände (11) in einer ersten Reihe an Montageeinheiten (21) angeordnet sind, die von einer ersten Seitenwand (14) des Kanals und einem Kanalboden (15) festgehalten oder abgestützt sind, und daß die Licht-Ausstattungsgegenstände (12) in einer zweiten Reihe an Montageeinheiten (22) angeordnet sind, die von einer zweiten, gegenüberliegenden Seitenwand (13) des Kanals und vom Kanalboden (15) festgehalten oder abgestützt sind.
6. Vorrichtung nach Anspruch 5, dadurch **gekennzeichnet**, daß die Montageeinheiten (22) eine Ausbildung eines abgewinkelten Streifens aufweisen, mit einem ersten Teil (25), der sich insgesamt in Querrichtung relativ zum Kanal (9) erstreckt, und einem zweiten Teil (26), der sich insgesamt in Tiefenrichtung im Kanal (9) erstreckt.

7. Vorrichtung nach Anspruch 6, dadurch **gekennzeichnet**, daß die endenden Kantenabschnitte der zweiten Teile (26) der Montageeinheiten (22) in einer sich in Längsrichtung erstreckenden Nut (41) nahe dem Kanalboden (15) geführt sind, und daß die endenden Kantenabschnitte der genannten ersten Teile (25) der Montageeinheiten (22) über Befestigungsmittel (31 bzw. 32) befestigt sind, die sich in eine sich in Längsrichtung erstreckende Nut (33 bzw. 35) nahe der jeweiligen Seitenwand (14 bzw. 13) des Kanals erstrecken, wobei die genannten zweiten Teile (26) der Montageeinheiten bevorzugt gegeneinander dort anliegen, wo sie einander überdecken, und bevorzugt in derselben Nut (41) nahe dem Kanalboden geführt sind.
8. Vorrichtung nach jedem vorangehenden Anspruch, dadurch **gekennzeichnet**, daß der Abschnitt (5) eine erste Kanalseitenwand (14) aufweist, die im wesentlichen eine vertikal nach unten gerichtete Fortsetzung eines Aufhängeelements (7) für den Abschnitt bildet, sowie eine zweite Kanalseitenwand (13) in Form eines im wesentlichen frei vorstehenden Abschnitts mit nach oben gekrümmtem Schnitt.

Revendications

1. Un dispositif pour éclairage indirect en conjonction avec une structure de plafond suspendue, qui inclut des sections suspendues et des moyens (1, 3) de panneau supportés sur celles-ci, le dispositif comprenant des moyens de goulotte profilée, disposés de telle sorte, qu'une goulotte profilée (9), s'étendant longitudinalement hors de vue, est formée, qui a une ouverture de goulotte profilée dirigée vers le haut pour l'émission de lumière, et dans laquelle, les éléments d'assujettissement (11, 12) de lampe, s'étendant longitudinalement, sont disposés pour l'émission de lumière à travers ladite ouverture, vers des portions d'éléments de couverture ou de paroi adjacentes, afin de procurer un éclairage indirect, lesdits moyens de goulotte profilée étant intégrés dans la structure de plafond suspendue de façon à définir une partie de transition entre des niveaux du plafond suspendu, caractérisé en ce que lesdits moyens de goulotte profilée comprennent une section (5), la section étant agencée afin de supporter une extrémité de moyens (3) de panneau de plafond horizontal à son pied et afin de supporter une extrémité inférieure de moyens (1) de panneau de plafond suspendu incliné se trouvant au-dessus, par ce moyen procurant ladite partie de transition, la section (5) étant suspendue dans un élément (7) de suspension de la structure de plafond suspendue, et en ce que des éléments d'assujettissement de lampe (11, 12) sont disposés, se chevauchant l'un l'autre, longitudinalement le long de la goulotte

- profilée (9) de la section (5), de sorte que les champs d'illumination, provenant des éléments d'assujettissement de lampe, se chevauchent l'un l'autre, par ce moyen évitant des effets d'ombre et/ou une distribution de lumière non uniforme dans l'éclairage indirect. 5
2. Un dispositif selon la revendication 1, caractérisé en ce que les éléments d'assujettissement de lampe (11, 12) sont susceptibles d'être ajustés, de façon translatable, dans la direction longitudinale de la goulotte profilée (9). 10
3. Un dispositif selon la revendication 1 ou la revendication 2, caractérisé en ce que les éléments d'assujettissement de lampe (11, 12) sont disposés dans au moins deux rangées, parallèles avec la direction longitudinale de la goulotte profilée (9). 15
4. Un dispositif selon la revendication 3, caractérisé en ce que les éléments d'assujettissement de lampe (11, 12), dans les rangées respectives, sont disposés sur les unités (21) de montage associées, respectives. 20
5. Un dispositif selon la revendication 4, caractérisé en ce que les éléments d'assujettissement de lampe (11), dans une première rangée, sont disposés sur des unités (21) de montage, qui sont fixées à, ou supportées par, une première paroi (14) latérale de la goulotte profilée et un fond (15) de goulotte profilée, et en ce que les éléments d'assujettissement de lampe (12), dans une seconde rangée, sont disposés sur des unités (22) de montage, qui sont fixées à, ou supportées par, une seconde paroi (13) latérale, opposée, de la goulotte profilée et le fond (15) de goulotte profilée. 25 30 35
6. Un dispositif selon la revendication 5, caractérisé en ce que les unités (22) de montage ont une configuration de bande formant un angle, ayant une première partie (25), qui s'étend généralement transversalement par rapport à la goulotte profilée (9), et une seconde partie (26), qui s'étend généralement en profondeur dans la goulotte profilée (9). 40 45
7. Un dispositif selon la revendication 6, caractérisé en ce que les portions de bord de terminaison des secondes parties (26) des unités (22) de montage sont guidées dans une rainure (41) s'étendant longitudinalement, adjacentes au fond (15) de goulotte profilée, et en ce que les portions de bord de terminaison desdites premières parties (25) des unités (22) de montage sont fixées, par l'intermédiaire de moyens (31 & 32, respectivement) de fixation, qui viennent en engagement avec une rainure (33 & 35, respectivement) s'étendant longitudinalement, adjacentes à la paroi latérale (14 & 13, respective- 50 55
- ment) respective de la goulotte profilée, lesdites secondes parties (26) des unités de montage, de préférence, portant l'une contre l'autre où elles se chevauchent et, de préférence, étant guidées dans la même rainure (41) adjacentes au fond de goulotte profilée.
8. Un dispositif selon une quelconque précédente revendication, caractérisé en ce que la section (5) a une première paroi (14) latérale de goulotte profilée, qui, essentiellement, forme une continuation s'étendant vers le bas, verticale, d'un élément (7) de suspension pour la section (5), et une seconde paroi (13) latérale de goulotte profilée, sous forme d'une portion de section courbée vers le haut, faisant saillie essentiellement librement.

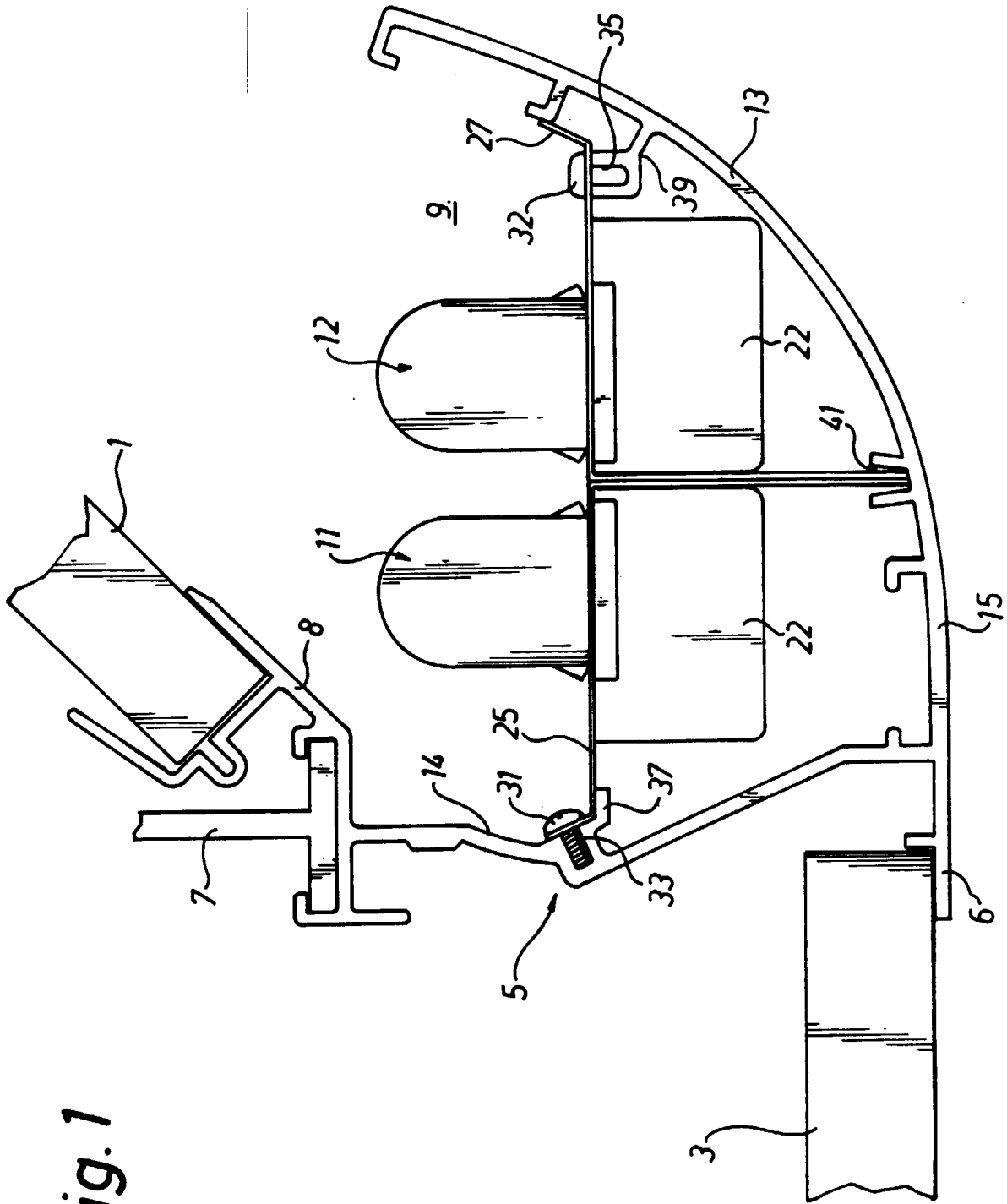

Fig. 1

