

(No Model.)

S. HARRIS.

SAFETY SWITCH FOR HIGH POTENTIAL CIRCUITS.

No. 524,717.

Patented Aug. 21, 1894.

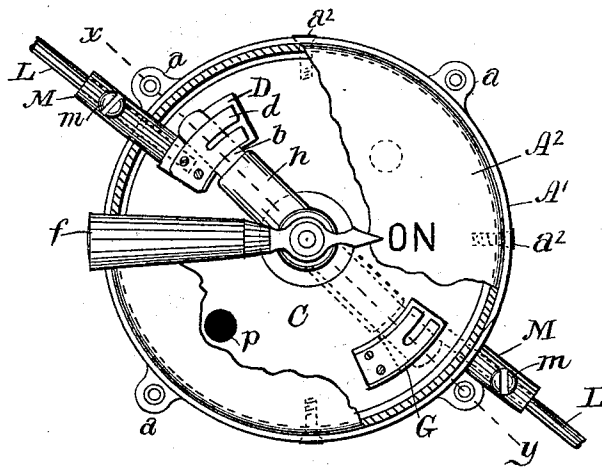

Fig. 1

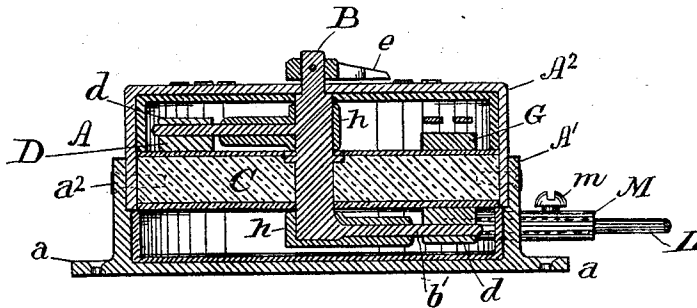

Fig. 2

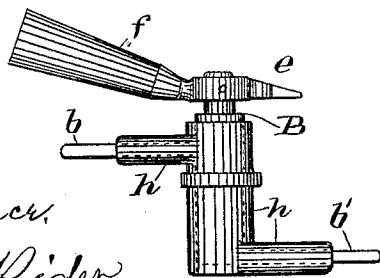

Fig. 3

Witnesses

Myron B. Vorce,

Roland Rider,

Inventor

Samuel Harris

by *M. Vorce*
Att'y.

UNITED STATES PATENT OFFICE.

SAMUEL HARRIS, OF CLEVELAND, OHIO.

SAFETY-SWITCH FOR HIGH-POTENTIAL CIRCUITS.

SPECIFICATION forming part of Letters Patent No. 524,717, dated August 21, 1894.

Application filed June 14, 1894. Serial No. 514,624. (No model.)

To all whom it may concern:

Be it known that I, SAMUEL HARRIS, a citizen of the United States, residing at Cleveland, in the county of Cuyahoga and State of Ohio, have invented certain new and useful Improvements in Safety-Switches for High-Potential Currents; and I do hereby declare the following to be a full, clear, and exact description of the invention, such as will enable others skilled in the art to which it appertains to make and use the same.

My invention relates to improvements in switches for electrical currents of high potential and large quantity, such as are employed to operate electric motors, cars, &c., the object being to more completely prevent the possibility of burning out the switch; and it consists in the novel features of construction and arrangement to effect such purpose as hereinafter fully described.

In the annexed drawings Figure 1 is a plan view of a switch embodying my invention, part of the top being broken away to show interior parts. Fig. 2 is a central vertical section of the device, taken on the line $x-y$ of Fig. 1. Fig. 3 is a detail showing a modification of the construction.

Great difficulty is at present found in constructing switches for high potential currents which will be free from danger of burning out if thrown open when the current is short-circuited or grounded on the negative side. Where the current is of great intensity and high potential it will frequently arc across from the contact block to the switch arm, when the switch is being thrown, melting and destroying the switch, or at least rendering it useless. To prevent this is the aim of my invention.

My improved switch consists of a box-like case or shell A, which may be conveniently formed of a base or bottom piece A' having lugs a for attaching it to any desired support, into or upon which fits an upper shell A², carrying the switch mechanism and which is secured to the base A' by lag-screws a^2 or other suitable means. The central stem B, of metal or conducting material, passes through the shell A² and through a disk of insulating material C secured thereto with sufficient space between to receive one of the terminal contact blocks D, which is secured

to the disk C. A similar space is left between the disk C and the bottom of the shell A', to accommodate the other contact block, which is secured to the other surface of the disk C. Contact arms $b b'$ extending from the stem B, and preferably in diametrically opposite directions, engage the terminal contact blocks D D to complete the circuit. An index e' with insulated handle f' is secured to the stem B outside the case for operating the switch.

The contact blocks D D secured to the disk C have springs $d d$ to hold the arms $b b'$ in firm contact, to prevent their accidental displacement by any jar or jolting of the car or other apparatus on which the switch is borne, and a block G, similar to D but not connected with the circuit, is secured to the disk C, diametrically opposite to D, to receive and hold the arms b when turned to the open position. One such holding block is usually sufficient, but one on each side of the disk can be used if deemed necessary. The arms $b b'$ are covered with insulating material h close up to the contact block, and the stem B may with advantage be covered with the same material on its exposed surface, or even throughout, as shown in Fig. 3.

The inner surface of the shells A' A², and both surfaces of the disk C, are covered with asbestos or other fire-proof material, and it will often be found advantageous to place a layer of insulating material between the case A and the support, unless the latter is itself a non-conductor of electricity.

The conducting wires L pass into connecting pieces M, to which they are secured by binding screws m , and which connecting pieces are either integral with or conductively attached to the contact blocks D, as by threading them thereinto, so as to complete the electrical connection of the wires L to the block D. Perforations p may be made in the disk C to ventilate the case and lessen the liability to heating.

By the above described construction the connection is broken at the same time on both sides of the switch, and on opposite sides of the insulating disk C, and as the contact arms $b b'$ and stem B, are insulated at all points except the small portion of the arms which engage the contact blocks D D, and

which portions are swung to the opposite sides of the switch in opening, the circuit is broken so quickly, so completely, and so widely, that the arcing across of the current is completely prevented. At the same time I am enabled by this construction to keep the size of the switch within moderate limits, which is also a desideratum, as the increase in size is very objectionable, and to dispense entirely with magnets and all other mechanism often used in switches.

What I claim as my invention, and desire to secure by Letters Patent, is—

1. The combination of a non-conducting disk, a single contact-block on each side of said disk at diametrically opposite points with connections to the circuit, a rotating stem extending through the disk and having on each side thereof and diametrically opposite each other a contact arm adapted to make circuit with the contact-blocks, said contact arms being conductively connected and rotating in planes parallel to the disk, and an index and handle on said stem for operating the switch, substantially as described.

2. The combination of a case, a disk of non-conducting material extending across the same, a single contact-block on each side of said disk at diametrically opposite points with connections to the circuit, a rotating stem extending into the case and through said disk and having on each side of said disk at diametrically opposite points a contact-arm adapted to make circuit with the contact-blocks, which said contact-arms are conductively connected and rotate in planes parallel to the disk, and an index and handle on said stem outside the case for operating the switch, substantially as described.

3. The combination of an insulated case, a disk of non-conducting material extending across the same, a single contact-block on each side of said disk at diametrically opposite points with connections to the circuit, a stem extending into the case and through said disk and having on each side of said disk and diametrically opposite a contact-arm adapted to make circuit with the contact-blocks, which said contact-arms are conductively connected and rotate in planes parallel to the disk, and an index and handle on said stem outside the case for operating the switch, substantially as described.

4. The combination of the two-part case, a

disk of non-conducting material secured to the upper part thereof, a single contact-block on each side of said disk at diametrically opposite points with connections to the circuit, holding-blocks opposite the contact-blocks and insulated from the circuit, a stem extending through the disk and through the top of the case and having on each side of the disk and diametrically opposite contact-arms adapted to make circuit with the contact-blocks, which said contact-arms are conductively connected and rotate in planes parallel to the disk, and an index and handle outside the case for operating the switch, substantially as described.

5. The combination of a case, a disk of non-conducting material extending across the same, a single contact-block on each side of said disk at diametrically opposite points with connections to the circuit, a stem extending into the case and through said disk and having on each side of said disk and diametrically opposed a contact-arm adapted to make circuit with the contact-block, said contact-arms being conductively connected and rotating in planes parallel to the disk, and said stem and arms being insulated except at the contact points and an index and handle on such stem outside the case for operating the switch, substantially as described.

6. The combination of the two-part insulated case, a disk of non-conducting material extending across the upper part thereof, a single contact-block on each side of said disk at diametrically opposite points with connections to the circuit, holding-blocks opposite the contact-blocks and insulated from the circuit, a stem extending through the disk and through the top of the case and having on each side of the disk and diametrically opposed a contact-arm adapted to make circuit with the contact-block, said contact-arms being conductively connected and rotating in planes parallel to the disk, and said stem and arms being insulated except at the contact points, and an index and handle outside the case for operating the switch, substantially as described.

In testimony whereof I hereto affix my signature in presence of two witnesses.

SAMUEL HARRIS.

Witnesses:

EDWARD MADDEN,
ROLAND RIDER.