

(12) INTERNATIONAL APPLICATION PUBLISHED UNDER THE PATENT COOPERATION TREATY (PCT)

(19) World Intellectual Property Organization
International Bureau



(43) International Publication Date
20 September 2001 (20.09.2001)

PCT

(10) International Publication Number
WO 01/69276 A2

- (51) International Patent Classification⁷: **G01R 33/34**, Archer, FL 32618 (US). **KING, Scott, B.** [US/US]; 8118 33/3415 S.W. 51st Boulevard, Gainesville, FL 32608 (US).
- (21) International Application Number: PCT/US01/07733 (74) Agents: **PARKER, James, S.** et al.; Saliwanchik, Lloyd & Saliwanchik, Suite A-1, 2421 N.W. 41st Street, Gainesville, FL 32606-6669 (US).
- (22) International Filing Date: 12 March 2001 (12.03.2001)
- (25) Filing Language: English (81) Designated States (*national*): AE, AG, AL, AM, AT, AU, AZ, BA, BB, BG, BR, BY, BZ, CA, CH, CN, CO, CR, CU, CZ, DE, DK, DM, DZ, EE, ES, FI, GB, GD, GE, GH, GM, HR, HU, ID, IL, IN, IS, JP, KE, KG, KP, KR, KZ, LC, LK, LR, LS, LT, LU, LV, MA, MD, MG, MK, MN, MW, MX, MZ, NO, NZ, PL, PT, RO, RU, SD, SE, SG, SI, SK, SL, TJ, TM, TR, TT, TZ, UA, UG, US, UZ, VN, YU, ZA, ZW.
- (26) Publication Language: English (84) Designated States (*regional*): ARIPO patent (GH, GM, KE, LS, MW, MZ, SD, SL, SZ, TZ, UG, ZW), Eurasian patent (AM, AZ, BY, KG, KZ, MD, RU, TJ, TM), European patent (AT, BE, CH, CY, DE, DK, ES, FI, FR, GB, GR, IE, IT, LU, MC, NL, PT, SE, TR), OAPI patent (BF, BJ, CF, CG, CI, CM, GA, GN, GW, ML, MR, NE, SN, TD, TG).
- (30) Priority Data: 09/522,808 10 March 2000 (10.03.2000) US
- (71) Applicant (*for all designated States except US*): **MRI DEVICES CORPORATION** [US/US]; Suite 350, 4445 S.W. 35th Terrace, Gainesville, FL 32608 (US).
- (72) Inventors; and
- (75) Inventors/Applicants (*for US only*): **MOLYNEAUX, David, A.** [US/US]; 9912 S.W. 22nd Lane, Gainesville, FL 32607 (US). **DUENSING, G., Randy** [US/US]; 11703 N.E. 4th Avenue, Gainesville, FL 32641 (US). **GOTSHAL, S., Uli** [US/US]; 2507 N.W. 65th Terrace, Gainesville, FL 32606 (US). **SCHUBERT, Thomas, E.** [US/US]; W319N1019 Balsam Lane, Delafield, WI 53018 (US). **HOLLAND, Alan** [US/US]; 211 East Main Street,
- Published:**
— *without international search report and to be republished upon receipt of that report*
- For two-letter codes and other abbreviations, refer to the "Guidance Notes on Codes and Abbreviations" appearing at the beginning of each regular issue of the PCT Gazette.*



WO 01/69276 A2

(54) Title: METHOD AND APPARATUS FOR NMR IMAGING

(57) Abstract: The subject invention pertains to a method and apparatus for Nuclear Magnetic Resonance (NMR) imaging. The subject method and apparatus are advantageous with respect to the use of RF coils for receiving signals in NMR scanners. The subject invention can utilize multiple coils to, for example, improve the signal to noise, increase the coverage area, and/or reduce the acquisition time. The use of multiple smaller surface or volume coils to receive NMR signals from the sample can increase the signal to noise ratio compared to a larger coil that has the same field of view and coverage area.

DESCRIPTIONMETHOD AND APPARATUS FOR NMR IMAGING

5

Cross-Reference to Related Applications

This is a continuation-in-part of co-pending application USSN 09/522,808, filed March 10, 2000.

Background of the Invention

10

The subject invention relates to the field of Nuclear Magnetic Resonance (NMR) imaging. The subject method and apparatus can allow an improved signal to noise ratio and is particularly advantageous for application to vertical field NMR imaging.

15

There are numerous examples of surface and volume coils described in the literature and available as commercial products. Several of these examples utilize multiple coils for an increased signal to noise ratio over a given field of view. In most cases, multiple coils examples have been applied to coil systems for use in a horizontal magnetic fields. Furthermore, the multiple coils are typically positioned to have no, or minimal, interaction with neighboring coils.

20

In order to image a large field of view, a first coil can be placed at one position, and one or more additional coils can be placed next to the first coil. If the coils interact with each other, it is preferable to switch the coils on and off such that only one coil is on at a time. Such a coil system can be referred to as a switchable coil. If the coils are positioned relative to one another such that they have minimal, or no, interaction, the coils can be switched on simultaneously allowing the entire field of view to be imaged at once. Such a coil system can be referred to as a phased array coil. The resultant image can have the signal to noise ratio of a small coil and the field of view of a large coil.

25

30

Advances in phased array coils have allowed linear coils to be positioned next to other linear coils, quadrature coils to be positioned next to other quadrature coils, and volume coils to be positioned next to other volume coils. In most cases, these coils have minimal mutual inductance and/or utilize some cancellation networks to reduce coupling. This concept can be applied to cover a larger area with several smaller coils.

35

U.S. Patent No. 4,825,162 (Roemer *et al.*) discloses the use of multiple noninteracting coils to acquire an NMR image. In U.S. Patent No. 4,825,162, the disclosed coils utilize simple linear designs that are intended to be used in a horizontal magnet system. These designs have no or minimal mutual inductance between the various coils, due to the relative position and/or the use of additional decoupling circuitry. However, while the goal of the Roemer device is to

extend the field of view while preserving the signal to noise, the device finds limited application because two or more linear coils cannot be positioned to see the same field of view while preserving the signal to noise ratio. Also, since the minimization of mutual inductance is the first criteria for isolation, secondary methods are then used to improve the isolation further.

5 U.S. Patent No. 5,394,087 (Molyneaux) discloses the use of quadrature coils positioned to minimize interaction between coils in order to achieve a higher signal to noise ratio than linear coils, while achieving a larger field of view compared to a single quadrature coil in horizontal field configurations. In U.S. Patent No. 5,951,474 (Matsunaga *et al.*), the use of similar geometries to those disclosed in U.S. Patent No. 5,951,474 is described for vertical field
10 configurations. U.S. Patent No. 5,258,717 discloses volume coils overlapped in the direction of the main field to extend the field of view, while preserving the signal to noise of a single volume coil for horizontal configurations. A major disadvantage of the configuration disclosed in the Molyneaux patent, the Matsunaga, *et al.* patent, and the Misic, *et al.* patent is the inability to use two or more linear coils positioned to see the same field of view while preserving the
15 signal to noise where only one quadrature coil sees the same field of view. Also, the configurations disclosed in the Molyneaux and Misic *et al.* patents are designed to work primarily with horizontal fields. Although the Matsunaga *et al.* device is intended for use in vertical fields, considerable coupling can occur between adjacent quadrature coils, negatively impacting the signal to noise ratio.

20 U.S. Patent No. 4,766,383 (Fox *et al.*) and U.S. Patent No. 5,185,577 (Minemura) describe configurations utilizing crossed ellipse coils, such that two elliptical coils are positioned to be orthogonal to one another for quadrature detection. The output is then sent to a quadrature combiner. A major disadvantage of the configurations disclosed in the Fox *et al.* and Minemura patents is that the crossed ellipse coils are used as quadrature coils, not array
25 coils, and can substantially increase the signal to noise as compared to a solenoid.

U.S. Patent No. 5,351,688 (Jones) describes the use of solenoids in a quadrature fashion, where one solenoid is used for the first direction of quadrature detection and a pair of solenoids are hooked together to make a Helmholtz pair in the second direction. Again, the output is sent to a quadrature combine. The major disadvantage of the configuration in the Jones patent is that
30 the solenoid is used with a set of solenoids that are configured as a Helmholtz pair and then fed into a quadrature combine. This results in no increased field of view and no significant increase in signal to noise due to the addition of the Helmholtz coils, as the center of the Helmholtz coils is far away from the center of the single solenoid and the field sensitivity drops as the square of the distance away from the center of the loop.

U.S. Patent No. 4,725,779 (Hyde, *et al.*) and U.S. Patent No. 4,721,913 (Hyde, *et al.*) disclose the use of a single or multiple loop gap resonators forming linear coils. The loop gap resonators consist of opposite rotating current coils and planar pair coils. A significant disadvantage of the apparatus disclosed in U.S. Patent No. 4,725,779 and U.S. Patent No. 4,721,913 is the use of a single linear coil (either opposite rotating or planar pair) with reduced sensitivity over a solenoid coil. U.S. Patent No. 4,866,387 (Hyde, *et al.*) discloses an opposite rotating current loop gap resonator and a planar pair which are combined to form a quadrature coil. U.S. Patent No. 4,866,387 also discloses a plurality of planar pair and opposite rotating coils which are positioned adjacent to one another to form a network of coils. A drawback with respect to the configuration disclosed in U.S. Patent No. 4,866,387 is the use of orthogonality for the isolation of overlapping and adjacent structures.

Brief Summary of the Invention

The subject invention pertains to a method and apparatus for Nuclear Magnetic Resonance (NMR) imaging. The subject method and apparatus are particularly advantageous with respect to the use of RF coils for receiving signals in NMR scanners. In a specific embodiment, the subject method and apparatus can utilize multiple coils to, for example, improve the signal to noise, increase the coverage area, and/or reduce the acquisition time. The use of multiple smaller surface or volume coils to receive NMR signals from the sample can increase the signal to noise ratio compared to a larger coil that has the same field of view and coverage area.

Brief Description of the Drawings

Figure 1 illustrates an embodiment of the subject invention utilizing three single loops.
Figure 2 illustrates an embodiment of the subject invention utilizing three series loops.
Figure 3 illustrates an embodiment of the subject invention utilizing three parallel loops.
Figure 4 illustrates an embodiment of the subject invention utilizing three loops and a Helmholtz pair of large loops.
Figure 5 illustrates an embodiment of the subject invention utilizing three loops, a Helmholtz pair top loops, and a Helmholtz pair bottom loops.
Figure 6 illustrates an embodiment of the subject invention utilizing three loops and two Helmholtz pairs side-by-side loops.
Figure 7 illustrates an embodiment of the subject invention utilizing crossed ellipse loops and an independent loop.

Figure 8 illustrates an embodiment of the subject invention utilizing crossed ellipse loops and a pair of opposite current loops.

Figure 9A illustrates an embodiment of the subject invention utilizing crossed ellipse loops and three loops.

5 Figure 9B illustrates an embodiment of the subject invention utilizing crossed ellipse loops, a center loop, and an Alderman-Grant loop.

Figure 10 illustrates an embodiment of a switching network for use with a three loop embodiment of the subject invention.

10 Figure 11 illustrates another embodiment of a switching network for use with a three loop embodiment of the subject invention.

Figure 12 illustrates a capacitive network which can be used to cancel mutual inductance between a single loop and crossed ellipse loops.

Figure 13 illustrates an embodiment of the subject invention utilizing five loops.

15 Figure 14A illustrates example even symmetry field patterns down the central axis produced by various drive currents for the loop configuration shown in Figure 13.

Figure 14B illustrates example odd symmetry field patterns down the central axis produced by various drive currents for the loop configuration shown in Figure 13.

Figure 15A illustrates an embodiment of the subject invention utilizing crossed ellipse loops.

20 Figure 15B illustrates a co-rotating current crossed ellipse configuration, in accordance with the subject invention.

Figure 15C illustrates an opposite current crossed ellipse configuration, in accordance with the subject invention.

25 Figure 16A illustrates a two-ring coil configuration such that the diameters, position, and relative currents in the rings are adjusted such that the EMF induced in ring #1 by $B_{1_{Ext.}}(x_1)$ is equal and opposite to the EMF induced in ring #2 by $B_{1_{Ext.}}(x_2)$, where $B_{1_{Ext.}}$ is produced by a current in an external coil.

30 Figure 16B shows a plot resulting from a Biot-Savart static calculation of the x-component B_x -field produced by the two-ring coil configuration shown in Figure 16A in the X-Y plane ($Z=0$ cm), where the dashed lines represent three different external circular surface coils of different diameters and positions which have zero net flux (arrows indicate direction of B_x -field) and are therefore isolated from the two-ring coil configuration.

Figure 17A shows a specific embodiment of a split solenoid design having a single end ring in accordance with the subject invention.

Figure 17B shows a specific embodiment of a split solenoid design having two end rings in accordance with the subject invention.

Figure 18 shows a specific embodiment of a mode trap which can be used to prevent or minimize coupling and force counter-rotating mode in the end rings of the coil designs shown in Figures 17A and 17B.

Detailed Description of the Invention

The subject invention relates to a method and apparatus for Nuclear Magnetic Resonance (NMR) imaging. The subject method and apparatus can take advantage of the properties of a system utilizing a solenoid located at or near essentially zero magnetic field planes of other solenoid configurations, and are particularly advantageous with respect to the use of RF coils for receiving signals in NMR scanners. The use of multiple smaller surface or volume coils to receive NMR signals from the sample can increase the signal to noise ratio compared to a larger coil that has the same field of view and coverage area. Accordingly, the subject method and apparatus can utilize multiple coils to, for example, improve the signal to noise, increase the coverage area, and/or reduce the acquisition time.

In the subject application, for ease of description, the coil configurations are often described in relation to the fields they would create if driven as generating coils. It is understood that this description, due to reciprocity between generating fields and receiving fields with a coil configuration, can also be descriptive of coil configurations for receiving magnetic fields. It is understood that a coil configuration associated with a magnetic field can be used for generating such magnetic field, detecting such magnetic field, or generating and detecting such magnetic field. In order to generate and receive, a coil configuration can, for example, be driven by a means for utilizing the coils for generating magnetic fields and then, after discontinuing the generation of the fields, a means for utilizing the coils for detecting can be employed for detecting magnetic fields associated with the coils. Accordingly, a zero-flux plane with respect to coil configuration designed for producing magnetic fields can be a plane in which any magnetic field would not be detected by the same coil configuration when used for receiving, or detecting, magnetic fields.

In a specific embodiment of the subject invention, three coils are positioned in a configuration such that two outer coils are coaxial, lie in parallel planes, and are driven by currents of opposite direction. In this three coil configuration, the center coil lies in a plane parallel to the planes of the outer two coils and is located near an essentially zero magnetic flux plane produced by the outer coils. If the outer coils have essentially identical shape and size, and the currents in the outer coils are approximately equal, such zero magnetic flux plane will

be approximately at the midpoint between the planes of the two outer coils. The position of this zero-flux plane with respect to the relative distance to each outer coil can be adjusted by changing the ratio of the magnitudes of the currents in the outer two coils. The shape of the zero-flux plane may change to some more complicated zero-flux contour as well.

5 Although the parallel, coaxial orientation of the outer coils is preferred, other configurations are also possible. For example, the two outer coils can be non-coaxial, but still lie in parallel planes. This embodiment can be useful for imaging, for example, a person's head when the head leans forward. In this case, the zero-flux contour may not be a plane, but a more complicated geometry. In another embodiment, the two outer coils are non-coaxial and do not
10 lie in parallel planes. This embodiment can be useful for imaging, for example, a person's shoulder, where the non-parallel coils can better conform to the shape of the shoulder. In addition, although loops of the approximate same size are preferred, different sized loops can also be used together.

 Figure 1 shows a preferred embodiment employing three parallel loops, **1B**, **2B**, and **3B**,
15 of the same size and shape. In this embodiment, loops **1B** and **3B** are approximately equidistant from the central loop **2B** and designed such that approximately equal currents can flow through them in opposite directions. The central loop, **2B**, can be considered a first channel and the other two loops **1B** and **3B** can be considered a second channel. Although the subject invention can be utilized even when significant coupling between the two channels exists, preferably the coils
20 are designed such that the coupling between the two channels is extremely low. Isolation circuitry can optionally be incorporated to reduce coupling. Advantageously, this design employing a single loop as a first channel and a pair of loops as a second channel can result in the pair of loops producing approximately zero magnetic flux in the plane of the single loop.

 Connections can be made between loops **1B** and **3B** such that the loops have currents
25 flowing in opposite directions. These connections can be, for example, series or parallel connections. Although, the solenoids shown in Figure 1 are single turns, or loops, the solenoids can be multiturn solenoids and can be wound as series loops or parallel loops. Figure 2 shows an embodiment utilizing series loops and Figure 3 shows an embodiment utilizing parallel loops. Referring to Figures 2 and 3, the connections between **4A** and **6A**, as well as **7A** and **9A**, may
30 be series or parallel as long as the currents are flowing in opposite directions in the two loops.

 The method and apparatus of the subject invention can also incorporate at least one Helmholtz pair which generates a magnetic field orthogonal to the fields produced by the solenoids of Figure 1. Figures 4, 5, and 6 illustrate a few examples where Helmholtz pairs are added to the embodiment of Figure 1. Although Figures 4, 5 and 6 illustrate the incorporation
35 of these Helmholtz coils with a three coil embodiment, these Helmholtz coils can be

incorporated with other embodiments of the subject invention as well, for example embodiment having additional coils, additional channels, different coil orientations, and/or different size coils. Once again, even though the loops in Figures 4, 5, and 6 are shown as single turns, or loops, the loops that make up a Helmholtz pair can also be multiturn solenoids and can be wound as series loops or parallel loops. Also, the connections between **26** and **27**, **31** and **32**, **33** and **34**, **37** and **40**, and **38** and **39** can be series or parallel and allow approximately equal currents to flow in the two loops of the pair.

Figure 4 shows an embodiment incorporating a "large loops" Helmholtz coil pair. Although the preferred embodiment of the large loops Helmholtz pair is shown, where the large static magnetic field used during NMR is oriented from bottom to top of the Figure, this pair can be rotated about the central axis of the cylinder formed by loops **23**, **24** and **25**. Also an additional large loop Helmholtz coil pair can be utilized if desired. For example, an additional large loop Helmholtz coil pair can be added to the top and bottom of the embodiment shown in Figure 4 such that essentially the entire cylinder formed by loops **23**, **24**, and **25** is surrounded by the two large loop Helmholtz coil pairs.

Figure 5 shows an embodiment which incorporates top/bottom loops. In this embodiment coil **31** and coil **32** form a top coil pair and coil **33** and coil **34** form a bottom coil pair. Preferably, the coil pairs overlap such that mutual inductance between coil **32** and coil **33** and between coil **31** and coil **34** is low. Most preferably, the amount of overlap can be selected so as to achieve approximately zero mutual inductance. Additional coil pairs can be added and/or the coil pair(s) can be rotated with respect to the central axis of the cylinder formed by loops **23**, **24** and **25**.

Figure 6 shows an embodiment of the subject invention incorporating side by side loops. Loops **37** and **40** form one loop pair and loops **38** and **39** form another. Preferably the amount of overlap of side by side loop pairs is chosen so that the mutual inductance of the loops is low, and, more preferably, the amount of overlap is chosen so that the mutual inductance is approximately zero. Additional loops can be added to one or more side by side pairs and/or additional side by side pairs can be added. Again, the side by side pairs can be rotated with respect to the central axis of the cylinder formed by loops **23**, **24** and **25**.

Another embodiment of the subject invention incorporates a crossed ellipse geometry with the three solenoid model shown in Figure 1, an example of which is shown in Figure 9A. The single solenoid can be removed if desired and the opposite current solenoids can be utilized with the crossed ellipse, as shown in Figure 8. Alternatively, the opposite current solenoids can be removed and the independent solenoid can be utilized with the crossed ellipse, as shown in Figure 7. For ease of illustration, the crossed ellipses have been drawn such that their

“intersection” is not at the top and bottom of the cylinder. Preferably, the intersection of the crossed ellipses (note the ellipses do not necessarily come into electrical contact at this intersection) is at the top and bottom of Figures 7, 8 and 9A, where the large external static magnetic field is oriented from the bottom to the top of the Figures. Most preferably, the intersection of the crossed ellipses is at the single loop, if present.

With respect to the embodiments shown in Figure 7 and Figure 9A, Figure 12 illustrates a specific embodiment of a capacitive network which can be used to minimize or cancel mutual inductance between the single solenoid and the crossed ellipse. Referring to Figure 12, **10A** and **10A'** represent the contacts for ellipse **10B** and are analogous to contacts **14A** and **14A'** for ellipse **14B** of Figure 9A; **12A** and **12A'** represent the contacts for loop **12B** and are analogous to contacts **17A** and **17A'** for loop **17B** of Figure 9A; and **11A** and **11A'** represent the contacts for ellipse **11B** and are analogous to contacts **15A** and **15A'** for ellipse **15B** of Figure 9A.

In a specific embodiment, the crossed ellipse/opposite rotating configuration shown in Figure 8 can be simplified by the superposition of the opposite rotating mode on the crossed ellipse conductors as shown in Figure 15. In a specific embodiment, the two loops that form the opposite rotating mode in Figure 8 can be removed, and the opposite rotating mode can be superimposed onto the crossed ellipse. In this embodiment, the crossed ellipse configuration can support two linear orthogonal modes, one for each loop, and a third mode which represents the opposite rotating mode. Alternatively, the crossed ellipse configuration can support two linear orthogonal modes, each a superposition of individual modes associated with each of the two coils. The opposite rotating mode can be isolated from the two linear orthogonal modes due to zero mutual inductance. Referring to Figures 8, 15B, and 15C, loop **19B** can produce a first linear mode **100** of the crossed ellipse, and loop **20B** can produce a second linear mode **101** of the crossed ellipse which is orthogonal to the first mode. The opposite rotating mode **103** of the crossed ellipse is shown in Figure 15C where the crossed ellipses have been broken apart in a manner to emphasize the currents for producing the opposite rotating mode **103**. Coupling to the structure can be achieved through capacitive or inductive methods. If desired, the opposite rotating mode can be produced on a second crossed ellipse coil pair aligned with the first coil pair.

Referring to the embodiment of the subject invention shown in Figure 9A, coil **17B** can act as a solenoid around the center of the region of interest. Coils **14B** and **15B** can form crossed ellipse coils, and coils **16B** and **18B** can form an opposite rotating coil centered on coil **17B**. The opposite rotating coil can be isolated via symmetry from coils **17B**, **14B**, and **15B**. Coils **14B** and **15B** can be isolated from one another by, for example, having their axes perpendicular to each other. In this arrangement, Coil **17B** can have strong mutual inductance with both coils

14B and **15B**. This inductance can be isolated by using one or more of various techniques known to those skilled in the art. The opposite rotating coil can have a zero flux in the center and improve the homogeneity of the coverage by producing fields away from the center. Advantageously, the embodiment of Figure 9A can produce excellent homogeneity down the axis of the cylinder.

In another embodiment of the subject invention, as shown in Figure 9B, coil pair **16B** and **18B** can be modified so as to produce an Alderman-Grant (Alderman, D.W. and Grant, D.M., *Jo. Magnetic Resonance* 36:447 [1979]) type of coil, such that coil **17B** is isolated from the Alderman-Grant coil due to the fields of the Alderman-Grant being perpendicular to the fields of coil **17B**. Such an Alderman-Grant coil can be achieved by adding a pair of conductors **30** and **31** to connect coils **16B** and **18B** such that conductors **30** and **31** carry the same magnitude current in opposite directions. The currents flowing in conductors **30** and **31** are split when the currents enter a coil, with one-half the magnitude of the current flowing in each half of the coil. For example, current flowing from conductor **30** flows one-half in each half of coil **18B** to conductor **31**, and current flowing from conductor **31** flows one-half in each half of coil **16B** to conductor **30**. In this embodiment, coils **17B** and the Alderman-Grant coil are isolated due to their perpendicular fields and coils **14B** and **15B** are isolated from one another by, for example, having their axes perpendicular to each other. Coil **17B** shares inductance and sample resistance with coils **14B** and **15B**, and the Alderman-Grant coil shares inductance and resistance with coil **14B** and **15B**.

With respect to the embodiment shown in Figure 9A, shared resistance between coils **17B** and **14B** and between coils **17B** and **15B** can limit the isolation. Preamplifier decoupling can increase the isolation to acceptable values. Also, due to the shared resistance, the amount of noise correlation in these channels is a consideration which should be taken into account.

Figures 10 and 11 illustrate switching networks which can be utilized with respect to the three solenoid embodiment, for implementing a method to allow the opposite rotation of the loop currents in either a series or parallel fashion. Figure 10 shows a switching network for allowing the outer two coils to have currents which either rotate in the same direction or in opposite directions. Referring to Figure 10, **1A'**, **2A'**, and **3A'** connect to the top contacts of loops **1B**, **2B**, and **3B** of Figure 1, while **1A**, **2A**, and **3A** connect to the bottom contacts. By closing switches **50** and **53**, loops **1B** and **3B** can be driven in the same rotation direction. By closing switches **51** and **52** and opening switches **50** and **53**, loops **1B** and **3B** can be driven in opposite rotation direction.

Figure 11 illustrates a more generalized switching network which can allow all three coils to have currents rotating in the same direction, or allow the center coil to operate

independently, while the two outer coil currents either rotate in the same direction or rotate in opposite directions. Referring to Figure 11, **1A'**, **2A'**, and **3A'** connect to the top contacts of loops **1B**, **2B**, and **3B** of Figure 1, while **1A**, **2A**, and **3A** connect to the bottom contacts. The network is driven at lead pairs **54** and **55**. If switches **50** and **53** are closed, loops **1B** and **3B** are driven in the same rotation direction with the center coil independent. By closing switch **56**, loop **2B** can be driven at lead pairs **55**. By closing switches **60**, **57**, **56**, **59**, and **58**, with switches **50** and **53** open, all three loops **1B**, **2B** and **3B** can be driven in the same direction rotation so as to function as a three turn solenoid. By closing switches **51** and **52** and opening switches **50** and **53**, loops **1B** and **3B** can be driven in opposite rotation direction. The network can also allow the three loops to operate as one loop for multiturn solenoid operation. The switching networks shown in Figures 10 and 11 can be modified to incorporate additional loops and/or channels as appropriate.

The method and apparatus of the subject invention can also be extended to more than two channels. With respect to the three solenoid example shown in Figure 1, the single loop coil can function as a first channel having even symmetry, while the two outer loop coils can function as a second channel having odd symmetry. In alternative embodiments, the single loop coil can be replaced by one of a variety of loop configurations having multiple loops which maintain even symmetry and, accordingly, preserve the isolation of the channels. For example, a configuration having multiple loops can be utilized such that loop pairs carrying equal currents are placed equidistant from the plane defining even and odd symmetry. For non-equal currents, the distance each loop is from the center plane can be adjusted such that the even symmetry is maintained.

Furthermore, additional loop configurations with even symmetry can be added to create additional channels. These even modes can have an even number (including zero) nodes, or zero flux contours. In a specific embodiment, a third channel, having even symmetry and two nodes can be incorporated. Such a third channel can be configured such that the two nodes are positioned in the magnetic field such that the net current induced in the first channel, of even symmetry, is approximately zero when the third channel is driven. Advantageously, both even symmetry channels can remain isolated from the odd symmetry channel. Further embodiments of the subject invention can add additional even symmetry channels having a different number of nodes in an analogous manner where each even symmetry channel having a different number of nodes can be orthogonal to each of the other even symmetry channels.

Likewise, additional loop configurations with odd symmetry can be added to create additional channels. These odd modes can have an odd number of nodes, or zero flux contours.

Advantageously, each odd modes having a different number of nodes can be orthogonal to each of the other odd modes and can be orthogonal to all even modes.

Referring to Figure 13, five loops oriented co-axially to one another, with bilateral symmetry around the center loop, are shown. Bilateral symmetry means any loop on one side of the center loop is the same distance to the center loop as a similar loop on the other side of the center loop. These five coaxial loops can be used to produce five current patterns that have negligible mutual inductance between each pair of patterns in a region of interest. Three of these current patterns have even symmetry, while two have odd symmetry around the center loop. The odd symmetry patterns are required to have zero current in the center loop, since odd symmetry of currents means that a loop on one side of center has opposite rotating current to the similar loop on the other side of center. Even symmetry of current requires a loop on one side of center to have equal current in the same direction to a similar loop on the other side of center. All even symmetry patterns will inherently have zero mutual inductance with all odd symmetry patterns. Figures 14A and 14B show example field patterns down the central axis of the loops which can be produced by certain current combinations for the loop configuration shown in Figure 13. The field patterns shown in Figures 14A and 14B illustrate how negligible mutual inductance can be produced between various field patterns.

With respect to embodiments described having opposite-rotating currents in a coaxial coil pair where the coils lie in a plane and are approximately the same size, the zero-flux contour typically lies between the two coils. In addition, two additional zero-flux contours can be considered to lie at infinity in either direction. However, if the parameters of the coil pair configuration are adjusted, one of the zero-flux contours of infinity can be brought toward the coil pair such that it remains outside the coil pair but is close enough to the coil pair to be useful with respect to the subject invention. In this case, another coil configuration can be placed at such zero-flux contour outside the coil pair.

Various embodiments illustrated in the Figures utilize coils residing in a plane. The subject apparatus and method are also applicable to coils not residing in a plane, where the subject invention can take advantage of essentially zero-flux contours which do not necessarily lie in a plane. By locating a coil in the zero-flux contours produced by other coil configurations, an independent channel can be achieved.

Referring to Figure 16A, an external coil is shown which can produce a non-uniform B-field at the position of a coil pair configuration. The coil pair can be adjusted such that the net electromagnetic force (EMF) caused by flux through the coils is zero, and, thus, net current is zero. In this way, the coil pair can be considered isolated from the external coil. By the principle of reciprocity, with such an arrangement, any B-field produced by the coil pair should produce

a net B-flux through the external coil of zero as well. The coil pair can produce a B-field with a component that has a zero crossing in a plane through the external coil, as shown in Figure 16B. In this way, both positive and negative contributions to the total B-flux exist which cancel upon integration over said plane. This is what is referred to as a zero-flux contour. One skilled in the art will recognize that this is equivalent to saying that the said coil and the external coil have zero mutual inductance.

As discussed, the subject invention can incorporate a plurality of coils such that a plurality of modes can be supported. For example, N loops with bilateral symmetry can support N-modes, corresponding to current patterns that all have zero net mutual inductive coupling to one another in a region of interest. The current patterns associated with these modes can be computed in a straightforward manner. As an example, the general case of N=5 loops, the matrix representing the inductive coupling from one mode to another can be written as:

$$\begin{matrix}
 L_1 & M_{12} & M_{13} & M_{14} & M_{15} \\
 M_{21} & L_2 & M_{23} & M_{24} & M_{25} \\
 M_{31} & M_{32} & L_3 & M_{34} & M_{35} \\
 M_{41} & M_{42} & M_{43} & L_4 & M_{45} \\
 M_{51} & M_{52} & M_{53} & M_{54} & L_5
 \end{matrix}$$

In general, $M_{ij}=M_{ji}$. For the special case of equivalent loops, the inductance (L) is identical for all loops. Additionally, $M_{12}=M_{45}$, $M_{23}=M_{34}$, $M_{14}=M_{25}$ and $M_{13}=M_{55}$ for a bilaterally symmetric arrangement of the five loops as shown, for example, in Figure 13. Therefore the inductive coupling matrix can be written:

$$\begin{matrix}
 L & M_{12} & M_{13} & M_{14} & M_{15} \\
 M_{12} & L & M_{23} & M_{24} & M_{14} \\
 M_{13} & M_{23} & L & M_{23} & M_{13} \\
 M_{14} & M_{24} & M_{23} & L & M_{12} \\
 M_{15} & M_{14} & M_{13} & M_{12} & L
 \end{matrix}$$

The eigenvectors of this matrix can be computed using ordinary means. The eigenvectors represent vectors of the form

$$\begin{pmatrix} i_1 \\ i_2 \\ i_3 \\ i_4 \\ i_5 \end{pmatrix} .$$

5

The five sets of current patterns corresponding to the eigenvectors are orthogonal and therefore have zero effective mutual inductance. It can be shown that any symmetrical arrangement of N equivalent loops has a coupling matrix that has non-degenerate, orthogonal eigenvectors and thus N current patterns that are isolated from one another.

10

Figures 17A and 17B illustrate embodiments of a split solenoid design which can allow access of anatomy parallel to a solenoid from one end as shown in Figure 17A, or both ends as shown in Figure 17B. The split solenoid shown in Figure 17A can be used, for example, for head, wrist, or foot imaging. The split solenoid design shown in Figure 17B is the Alderman-Grant type coil as shown, and discussed with respect to, Figure 9C, and shows the direction of the current. The coil design shown in Figure 9C can be used, for example, for knee, ankle, elbow, torso, or cardiac imaging. The currents in the end rings run opposite, or counter-rotating, in each half of the loop. If desired, the split solenoid designs shown in Figures 17A and 17B can be combined with other coils, such as those shown in Figures 7, 8, and 9, to add another mode of sensitivity. In a specific embodiment, loop **18B** of Figure 9B can be replaced by a straight conductor connecting conductors **30** and **31** directly. Replacing loop **18B** with a straight conductor results in a coil design shown in Figure 17A. When combined with another geometry, a mode trap such as the one shown in Figure 18 can be added to prevent or minimize coupling and force the counter-rotating mode in the end ring. Other mode trap designs can be utilized with the subject invention and function to prevent, or minimize, ring current and lead to split current in the coil. A mode trap can be incorporated at one or both of the connection points between the straight conductor and the coil shown in Figure 17A, and at one, two, three, or all four of the connection points between the straight conductors and the end coils shown in Figure 17B. The mode trap shown in Figure 18 can be incorporated by connecting each of the x terminals to the coil conductors and the z terminal to the straight conductor. Preferably, with respect to the coil design shown in Figure 17B, at least one mode trap is incorporated at each end, and more preferably a mode trap is incorporated at each connection point between the straight conductor and the coil(s).

15

20

25

30

35

It should be understood that the examples and embodiments described herein are for illustrative purposes only and that various modifications or changes in light thereof will be

suggested to persons skilled in the art and are to be included within the spirit and purview of this application.

Claims

- 1 1. A coil configuration for a magnetic resonance imaging system, comprising:
2 a pair of coils in an opposite rotation orientation associated with a first magnetic field
3 in a region of interest; and
4 a single coil associated with a second magnetic field in the region of interest, wherein
5 the single coil is positioned at an essentially zero-flux contour with respect to the first magnetic
6 field.
- 1 2. The configuration according to claim 1, further comprising:
2 a means for utilizing the pair of coils for detecting the first magnetic field; and
3 a means for utilizing the single coil for detecting the second magnetic field.
- 1 3. The configuration according to claim 1, further comprising:
2 a means for utilizing the pair of coils for generating the first magnetic field; and
3 a means for utilizing the single coil for generating the second magnetic field.
- 1 4. The configuration according to claim 2, further comprising:
2 a means for utilizing the pair of coils for generating the first magnetic field; and
3 a means for utilizing the single coil for generating the second magnetic field.
- 1 5. The configuration according to claim 2, wherein said coils of said pair of coils and
2 said single coil are selected from the group consisting of: a single turn loop, a multiturn solenoid
3 wound as series loops, and a multiturn solenoid wound as parallel loops.
- 1 6. The configuration according to claim 1, wherein each of said pair of coils and said
2 single coil lie in planes parallel to each other, and wherein said essentially zero-flux contour is
3 an essentially zero-flux plane.
- 1 7. The configuration according to claim 6, wherein the region of interest is essentially
2 within a cylinder created by the pair of coils, and wherein the pair of coils and the single coil are
3 co-axial.
- 1 8. The configuration according to claim 2,
2 wherein the single coil is a first channel and the pair of coils is a second channel such
3 that coupling between the first channel and second channel is low.

4 9. The configuration according to claim 8, wherein coupling between the first channel
5 and second channel is approximately zero.

1 10. The system according to claim 1, wherein the zero-flux contour is located between
2 the pair of coils.

1 11. The system according to claim 1, wherein the zero-flux contour is located outside
2 the pair of coils.

1 12. The system according to claim 10, wherein a second zero-flux contour with respect
2 to the first magnetic field is located outside the pair of coils, further comprising a second single
3 coil for generating a third magnetic field in the region of interest, wherein the second single coil
4 is positioned at the second zero-flux contour with respect to the first magnetic field.

1 13. The configuration according to claim 10,
2 wherein the single coil is positioned approximately equidistance from each of the pair
3 of coils.

1 14. The configuration according to claim 10, wherein the single coil is positioned closer
2 to one of the coils of the pair of coils than to the other.

1 15. The configuration according to claim 1, further comprising:
2 at least one Helmholtz coil pair associated with a third magnetic field essentially
3 orthogonal to the first and second magnetic fields in the region of interest.

1 16. The configuration according to claim 15, further comprising a means for utilizing
2 said at least one Helmholtz coil pair for generating the third magnetic field.

1 17. The configuration according to claim 15, wherein said Helmholtz coil pair is of a
2 configuration selected from the group consisting of: large loops, top/bottom loops, side by side
3 loops, and a combination thereof.

1 18. The configuration according to claim 1, further comprising:
2 a crossed ellipse coil pair associated with a third magnetic field and a fourth magnetic
3 field in the region of interest.

4 19. The configuration according to claim 18, further comprising:
5 a means for utilizing said crossed ellipse coil pair for detecting the third magnetic field
6 and the fourth magnetic field.

1 20. The configuration according to claim 18, further comprising:
2 a means for utilizing the crossed ellipse coil pair for generating the third magnetic field
3 and the fourth magnetic field.

1 21. The configuration according to claim 18,
2 wherein the configuration of the crossed ellipse coil pair is selected from the group
3 consisting of an opposite current crossed ellipse configuration and a co-rotating crossed ellipse
4 configuration.

1 22. The configuration according to claim 18,
2 wherein the configuration of the crossed ellipse coil pair is selected such as to support
3 a driving current for producing fields consistent with an opposite current crossed ellipse
4 configuration and a co-rotating crossed ellipse configuration.

1 23. The configuration according to claim 18,
2 wherein said system is designed for use in a static external magnetic field, and wherein
3 said crossed ellipse coil pair is positioned such that a line connecting a first crossing and a
4 second crossing of the crossed ellipse coil pair is parallel with said static external magnetic field.

1 24. The configuration according to claim 18,
2 wherein the pair of coils is isolated via symmetry from the crossed ellipse coil pair of
3 and the single coil.

1 25. The configuration according to claim 1,
2 wherein said pairs of coils are connected together by a pair of electrical conductors to
3 form an Alderman-Grant coil pair.

1 26. The configuration according to claim 1, further comprising:
2 a switching means for allowing the pair of coils and the single coil to operate in and
3 switch between two or more of the modes in the group consisting of:

- 4 (i) the coils of the pair of coils and the single coil having currents rotating in the same
5 direction;
- 6 (ii) the coils of the pair of coils having currents rotating in the same direction, with the
7 single coil operating independently;
- 8 (iii) the coils of the pair of coils having currents rotating in opposite directions, with the
9 single coil operating independently; and
- 10 (iv) the coils of the pair of coils having currents rotating in the same direction and the
11 single coil having a current rotating in an opposite direction with respect to the currents of the
12 pair of coils.

1 27. A coil configuration for a magnetic resonance imaging system, comprising:
2 a pair of coils in an opposite rotation orientation associated with a first magnetic field
3 in a region of interest; and
4 a crossed ellipse coil pair associated with a second magnetic field in the region of
5 interest.

1 28. The configuration according to claim 27,
2 wherein the pair of coils is isolated via symmetry from the crossed ellipse coil pair.

1 29. A coil configuration for a magnetic resonance imaging system, comprising:
2 a crossed ellipse coil pair;
3 a means for utilizing the crossed ellipse pair for detecting magnetic fields associated
4 with a first linear mode;
5 a means for detecting utilizing the crossed ellipse coil pair for magnetic fields associated
6 with a second linear mode;
7 wherein said second linear mode is orthogonal to said first linear mode; and
8 a means for utilizing the crossed ellipse coil pair for detecting magnetic fields associated
9 with an opposite rotating mode.

1 30. The coil configuration according to claim 29;
2 wherein the opposite rotating mode is isolated from the first and second linear modes
3 due to zero mutual inductance.

1 31. The coil configuration according to claim 29, further comprising a second crossed
2 ellipse coil pair aligned with the first crossed ellipse coil pair, wherein the means for detecting

3 magnetic fields associated with the opposite rotating mode utilizes the second crossed ellipse
4 coil pair.

1 32. A coil configuration for a magnetic resonance imaging system, comprising:
2 a single coil associated with a first magnetic field in a region of interest; and
3 a crossed ellipse coil pair associated with a second magnetic field and a third magnetic
4 field in the region of interest.

1 33. The configuration according to claim 32, further comprising:
2 a capacitive network which minimizes mutual inductance between the single coil and
3 the crossed ellipse coil pair.

1 34. The configuration according to claim 32,
2 wherein the configuration of the crossed ellipse coil pair is selected from the group
3 consisting of an opposite current crossed ellipse configuration and a co-rotating crossed ellipse
4 configuration.

1 35. The configuration according to claim 32,
2 wherein the configuration of the crossed ellipse coil pair is selected such as to support
3 a driving current for producing fields consistent with an opposite current crossed ellipse
4 configuration and a co-rotating crossed ellipse configuration.

1 36. The configuration according to claim 1, further comprising:
2 at least one additional pair of coils, wherein said pair of coils in an opposite orientation
3 has odd symmetry with respect to a plane,
4 wherein each of said at least one additional pair of coils is associated with a
5 corresponding at least one additional magnetic field,
6 wherein each of said at least one additional pair of coils has even symmetry with respect
7 to the plane and is associated with one of said at least one additional magnetic field such that
8 said single coil is a first channel, said pair of coils in an opposite orientation is a second channel,
9 and each of said at least one additional pair of coils is an additional channel which is orthogonal
10 to the first channel, second channel, and each of the other additional channels.

1 37. The configuration according to claim 1, further comprising:
2 at least one additional pair of coils, wherein said pair of coils in an opposite orientation
3 has odd symmetry with respect to a plane,
4 wherein each of said at least one additional pair of coils is associated with a
5 corresponding at least one additional magnetic field,
6 wherein each of said at least one additional pair of coils has odd symmetry with respect
7 to the plane and is associated with one of said at least one additional magnetic field such that
8 said single coil is a first channel, said pair of coils in an opposite orientation is a second channel,
9 and each of said at least one additional pair of coils is an additional channel which is orthogonal
10 to the first channel, second channel, and each of the other additional channels.

1 38. A coil configuration for a magnetic resonance imaging system, comprising:
2 a plurality of coils with bilateral symmetry,
3 wherein said plurality of coils is associated with a plurality of modes such that the
4 number of modes is less than or equal to the number of coils, wherein said plurality of modes
5 correspond with a plurality of current patterns, each of said plurality of current patterns having
6 zero net mutual inductive coupling to each of the other of said plurality of current patterns in a
7 region of interest.

1 39. The configuration according to claim 38, further comprising:
2 a means for utilizing the plurality of coils for detecting magnetic fields associated with
3 the plurality of current patterns.

1 40. The configuration according to claim 38, further comprising:
2 a means for utilizing the plurality of coils for generating magnetic fields associated with
3 the plurality of current patterns.

1 41. A method of detecting magnetic fields in a magnetic resonance imaging system,
2 comprising the following steps:
3 detecting a first magnetic field in the field of interest utilizing a pair of coils in an
4 opposite rotation orientation associated with the first magnetic field in a region of interest; and
5 detecting a second magnetic field in the region of interest utilizing a single coil
6 associated with the second magnetic field in the region of interest,
7 wherein the single coil is positioned at an essentially zero-flux contour with respect to
8 the first magnetic field.

9 42. A method of detecting magnetic fields in a magnetic resonance imaging system,
10 comprising the following steps:

11 detecting a first magnetic field in a region of interest utilizing a pair of coils in an
12 opposite rotation orientation associated with the first magnetic field in the region of interest; and
13 detecting a second magnetic field and a third magnetic field in the region of interest
14 utilizing a crossed ellipse coil pair,

15 wherein one of the coils of the crossed ellipse coil pair is associated with the second
16 magnetic field and the other of the coils of the crossed ellipse coil pair is associated with the
17 third magnetic field.

1 43. A method of detecting magnetic fields in a magnetic resonance imaging system,
2 comprising the following steps:

3 detecting magnetic fields associated with the first linear mode of a crossed ellipse coil
4 pair;

5 detecting magnetic fields associated with a second linear mode of the crossed ellipse coil
6 pair; and

7 detecting magnetic fields associated with an opposite rotating mode of the crossed
8 ellipse coil pair,

9 wherein the second linear mode is orthogonal to the first linear mode.

1 44. A method of detecting magnetic fields in a magnetic resonance imaging system,
2 comprising the following steps:

3 detecting a first magnetic field in a region of interest utilizing a single coil associated
4 with the first magnetic field in the region of interest; and

5 detecting a second magnetic field and a third magnetic field in a region of interest
6 utilizing a crossed ellipse coil pair,

7 wherein one of the coils of the crossed ellipse coil pair is associated with the second
8 magnetic field and the other of the coils of the crossed ellipse coil pair is associated with the
9 third magnetic field.

1 45. A method of detecting magnetic fields in a magnetic resonance imaging system,
2 comprising the following steps:

3 positioning a plurality of coils with respect to a region of interest such that the plurality
4 of coils support a plurality of modes corresponding to a plurality of current patterns; and

5 detecting the plurality of modes associated with the plurality of coils,

6 wherein the number of coils is greater than or equal to the number of modes, and
7 wherein each of the plurality of current patterns has zero net mutual inductive coupling to each
8 of the other of the plurality of current patterns in a region of interest.

1 46. The configuration according to claim 25, further comprising:
2 at least one mode trap, wherein each of said at least one mode trap is interconnected
3 between one of the electrical connectors and one of the Alderman-Grant coil pair coils.

1 47. The configuration according to claim 25,
2 wherein one of the Alderman-Grant coil pair coils is replaced by a straight conductor
3 connecting the pair of electrical conductors.

1 48. The configuration according to claim 47, further comprising:
2 at least one mode trap, wherein each of said at least one mode trap is interconnected
3 between one of the electrical connectors and one of the Alderman-Grant coil pair coils.

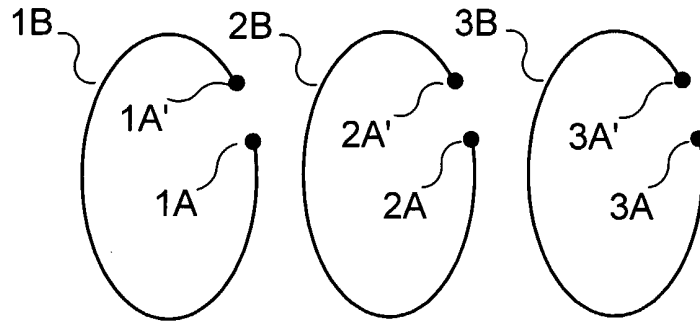

FIG. 1

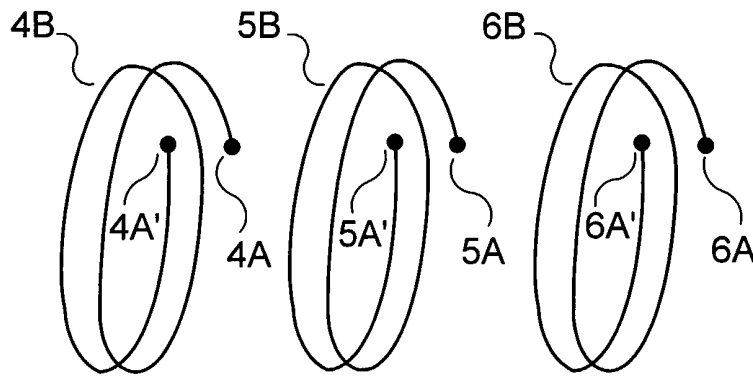

FIG. 2[®]

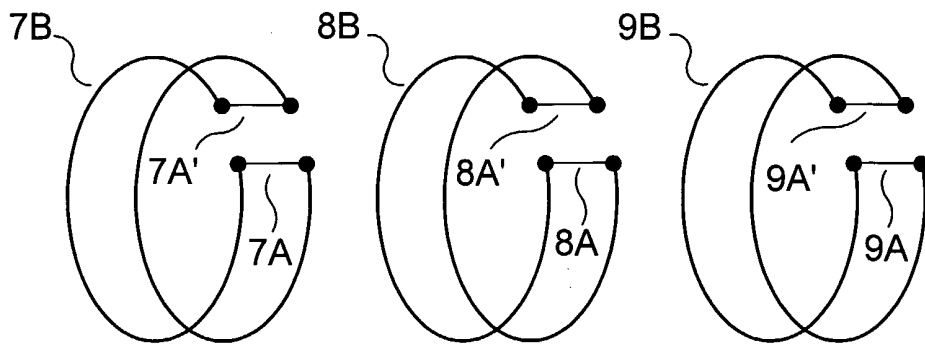

FIG. 3

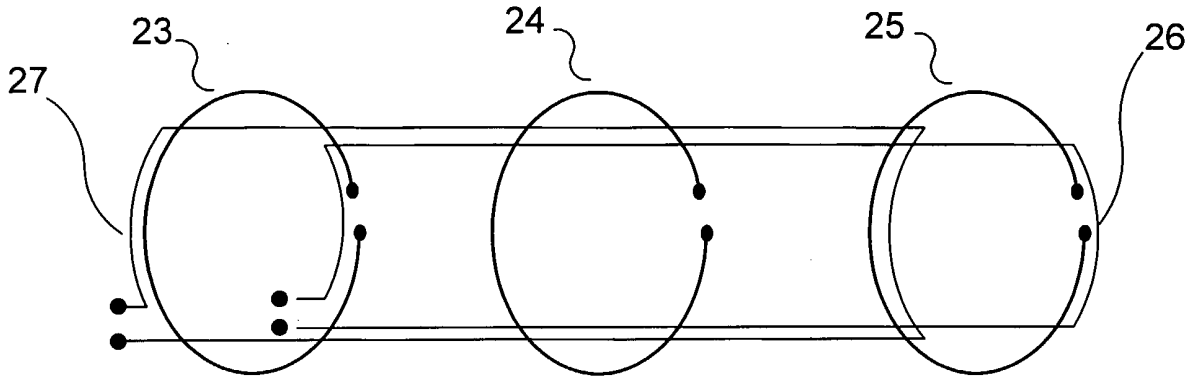

FIG. 4

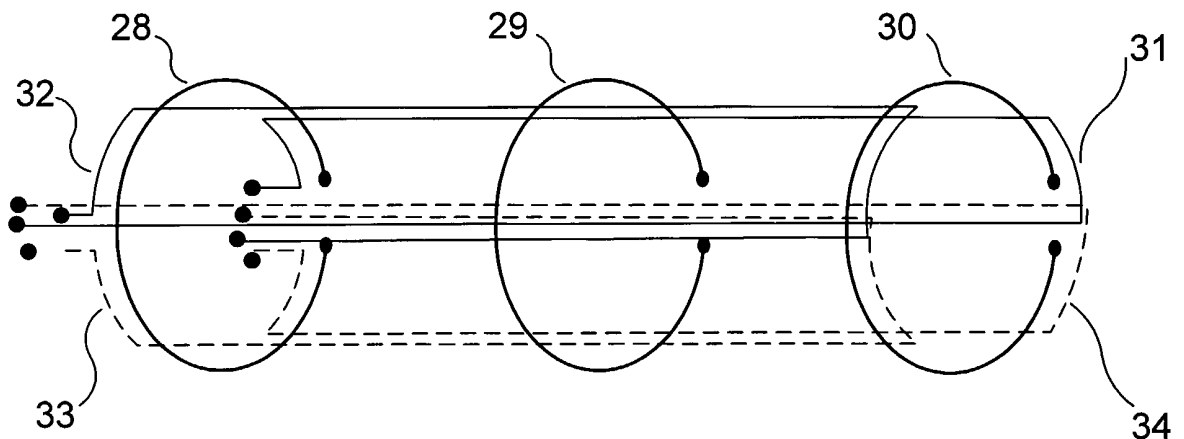

FIG. 5

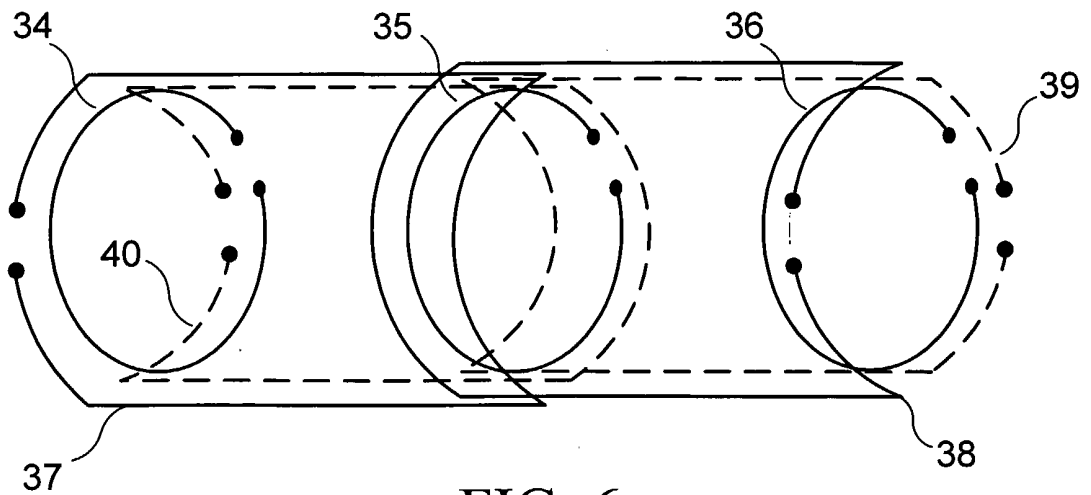

FIG. 6

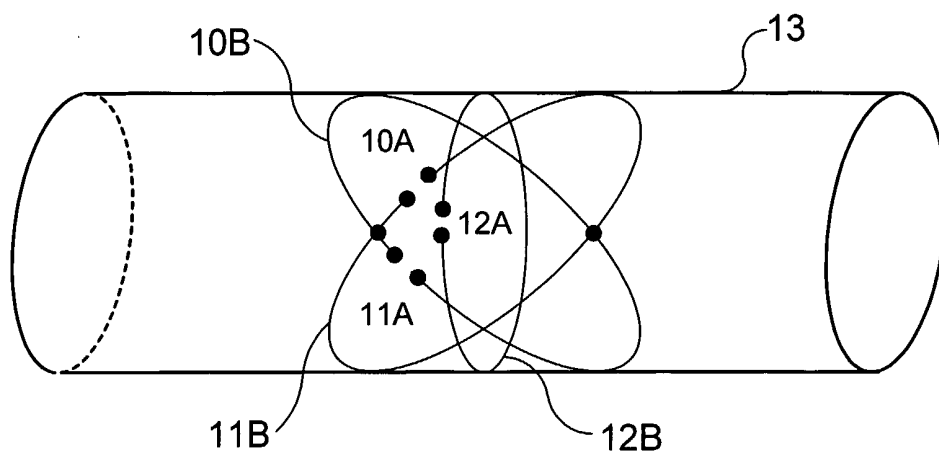

FIG. 7

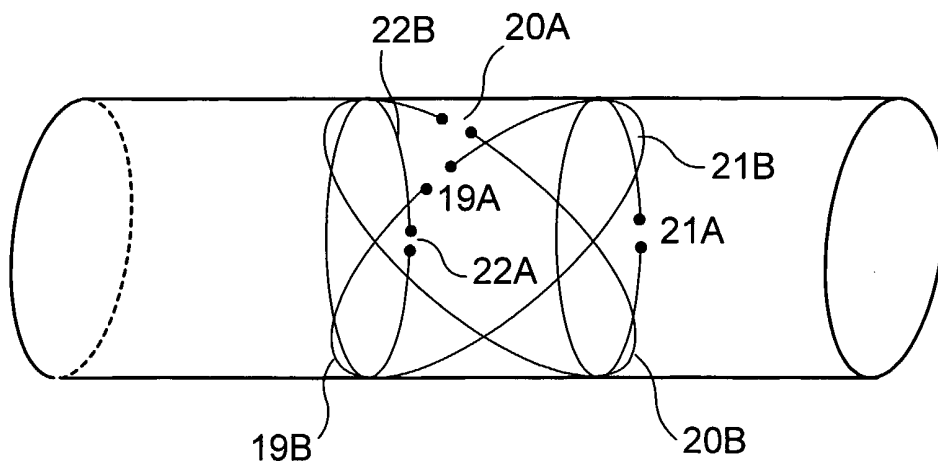

FIG. 8

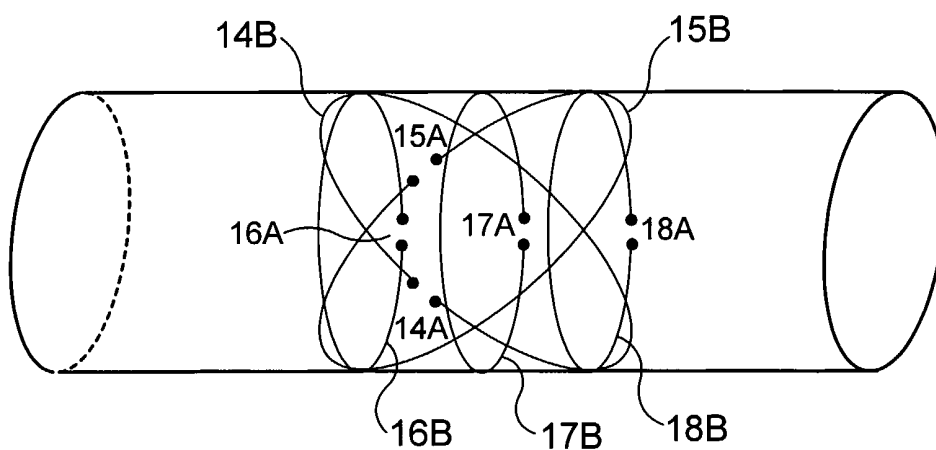

FIG. 9A

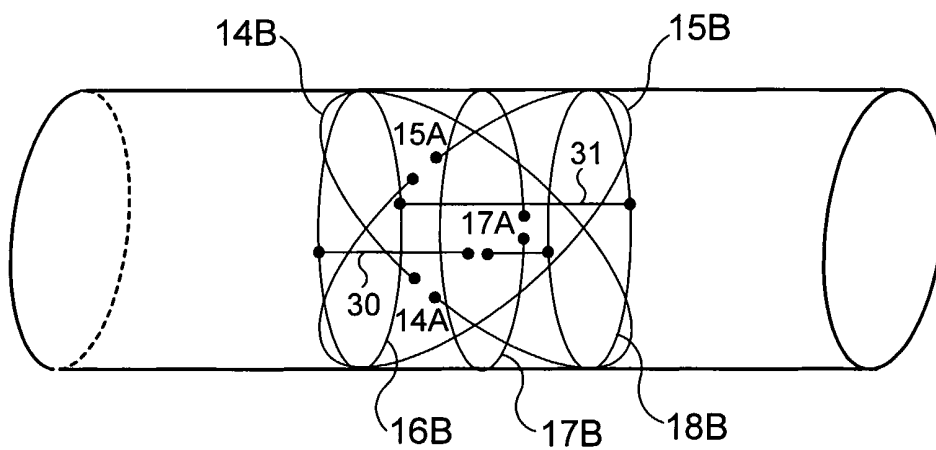

FIG. 9B

5/12

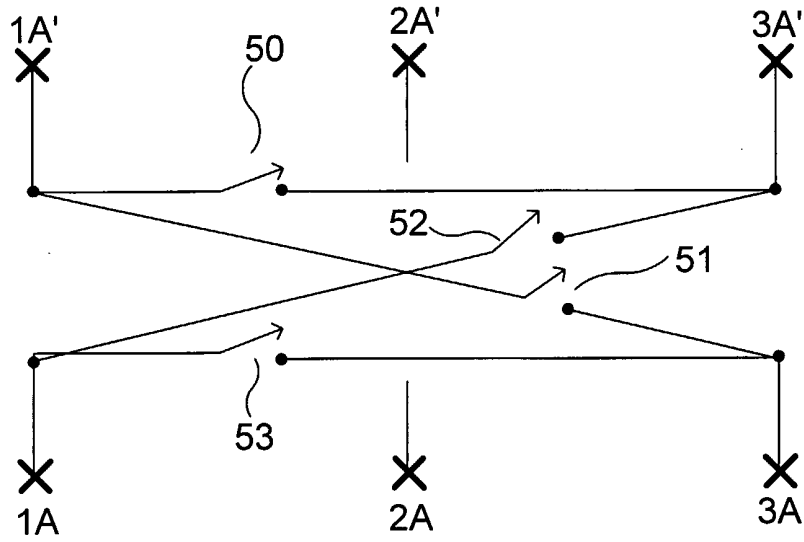

FIG. 10

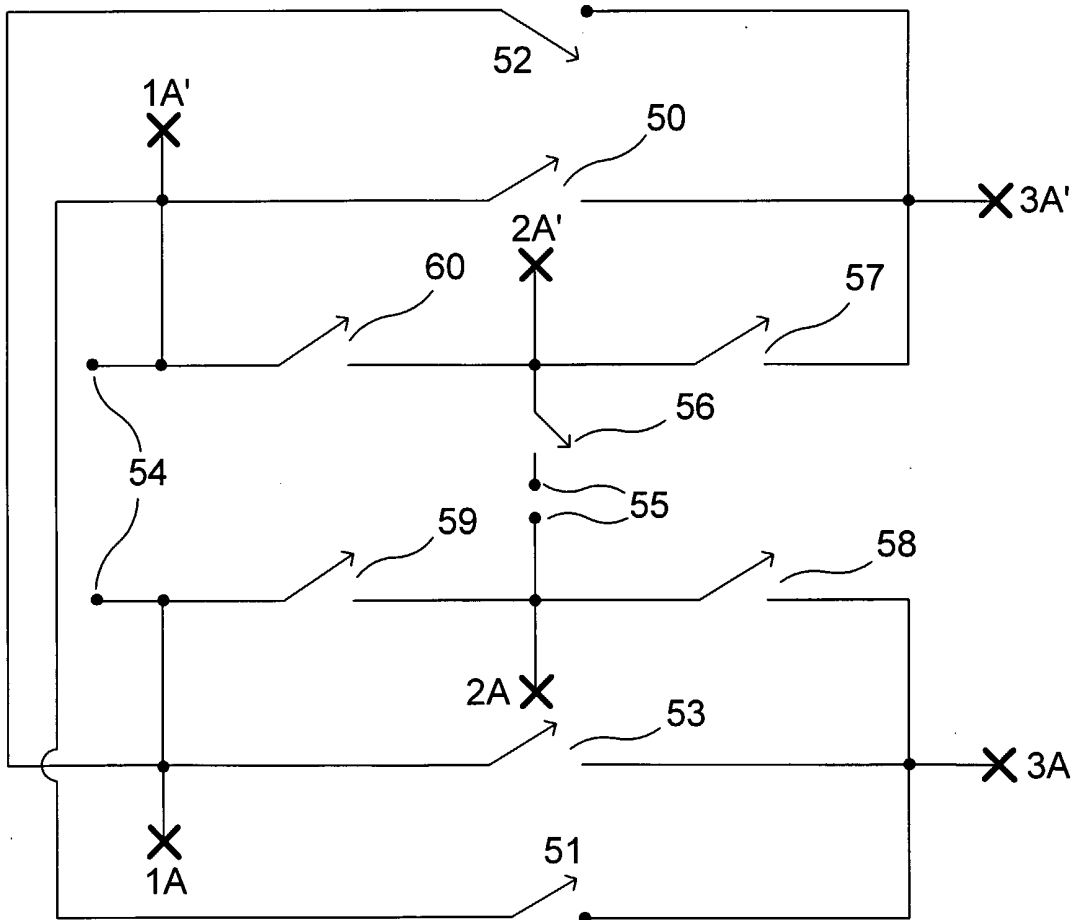

FIG. 11

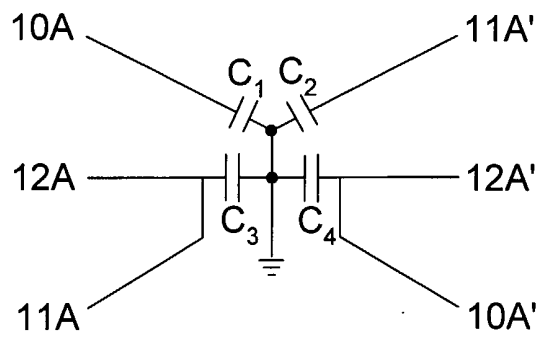

FIG. 12

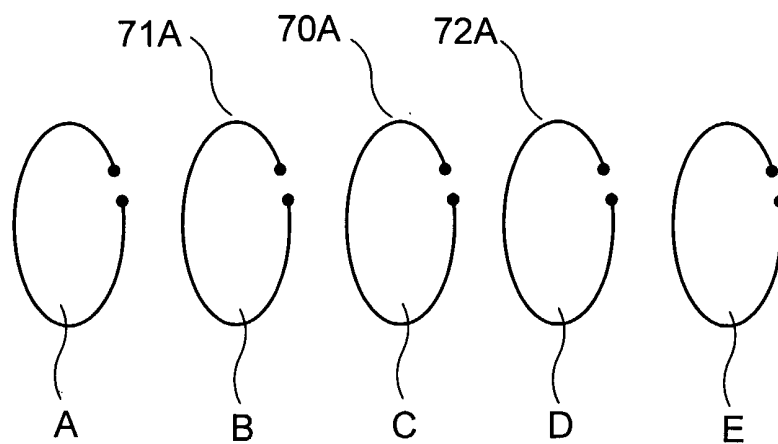

FIG. 13

7/12

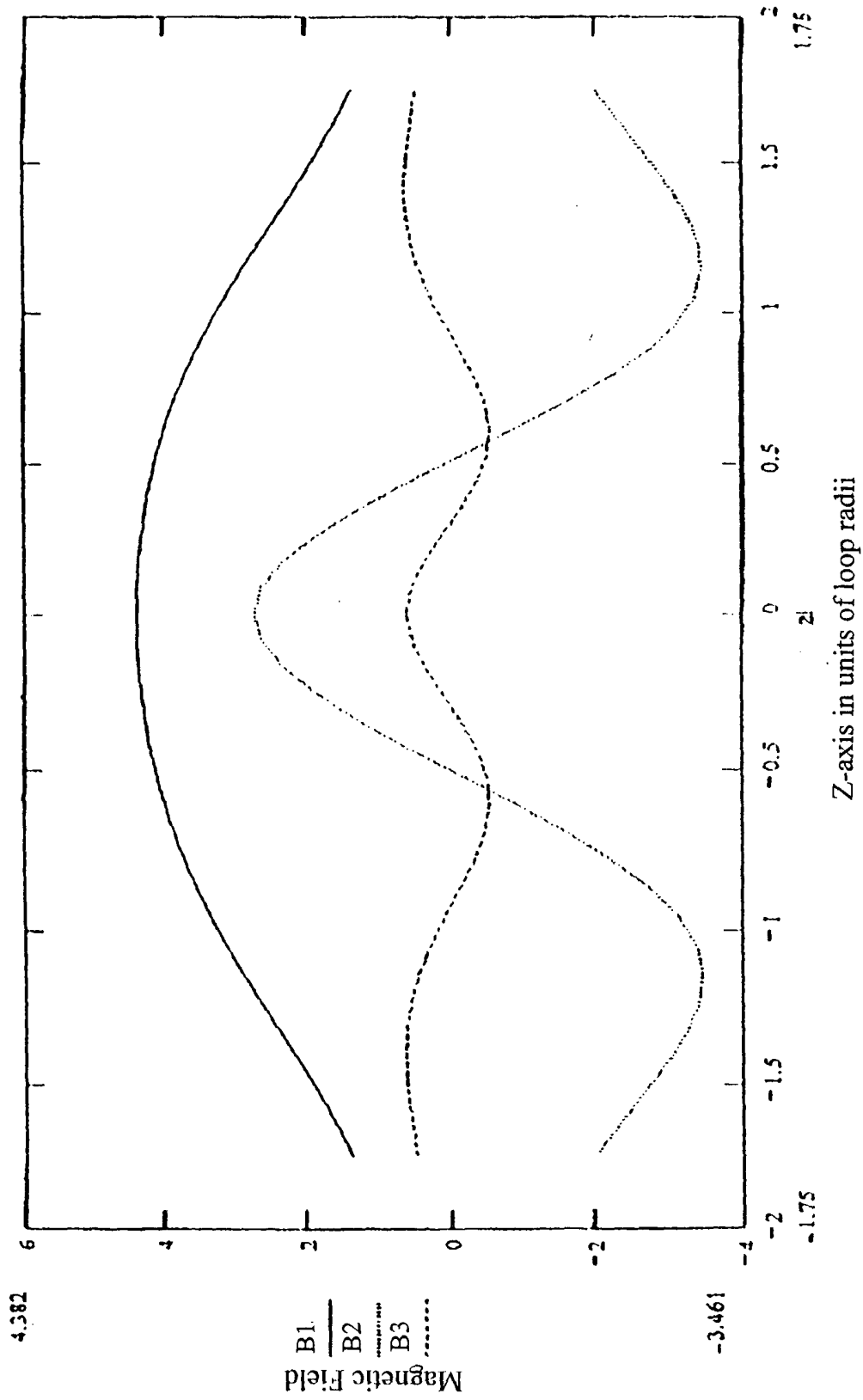

FIG. 14A

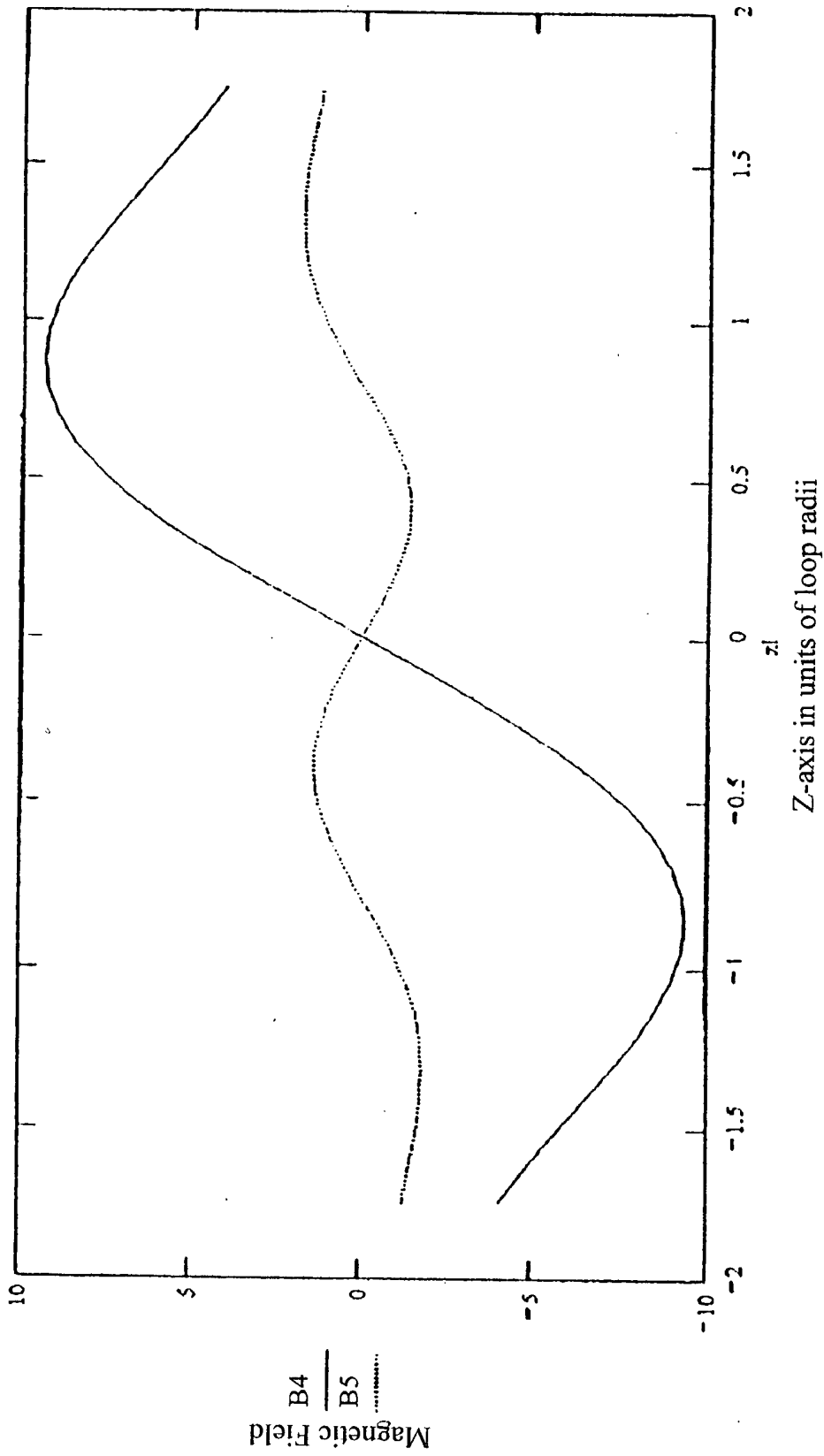

FIG. 14B

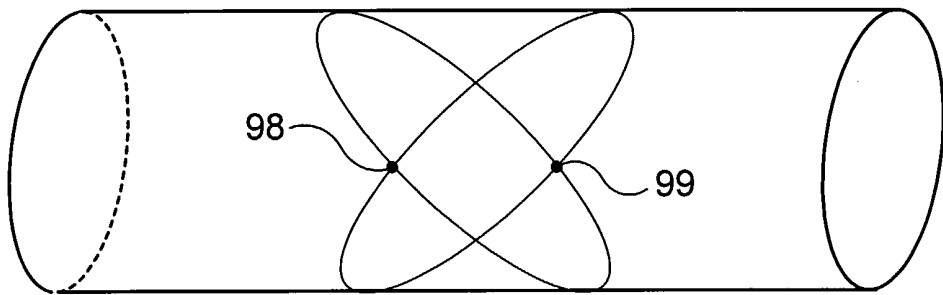

FIG. 15A

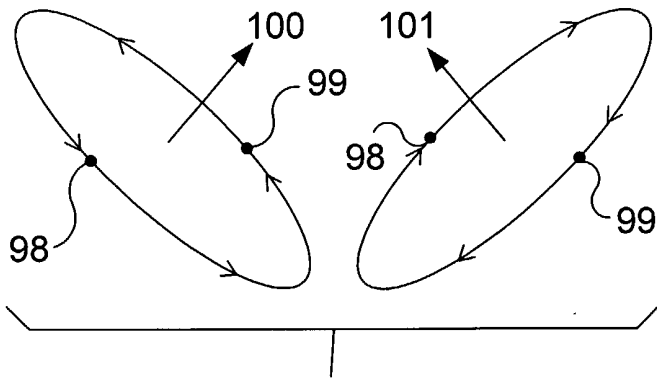

FIG. 15B

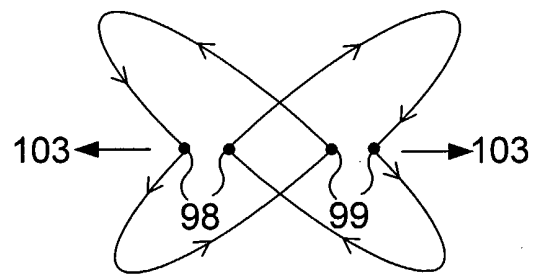

FIG. 15C

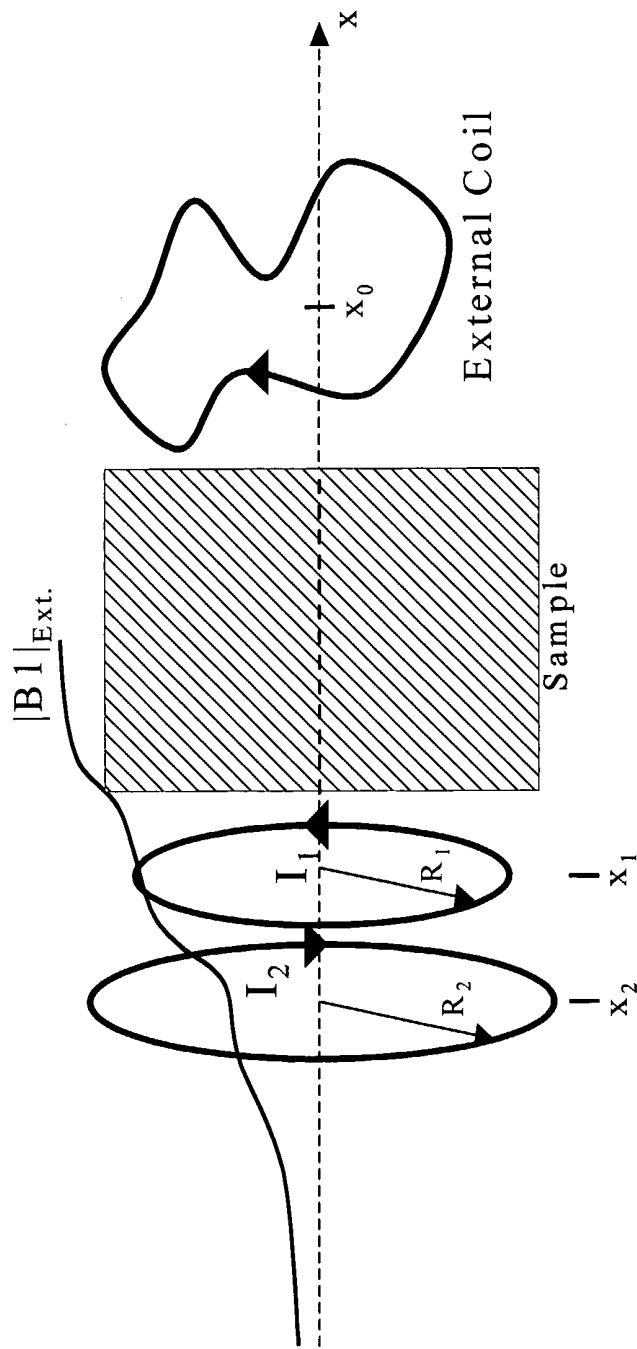

FIG. 16A

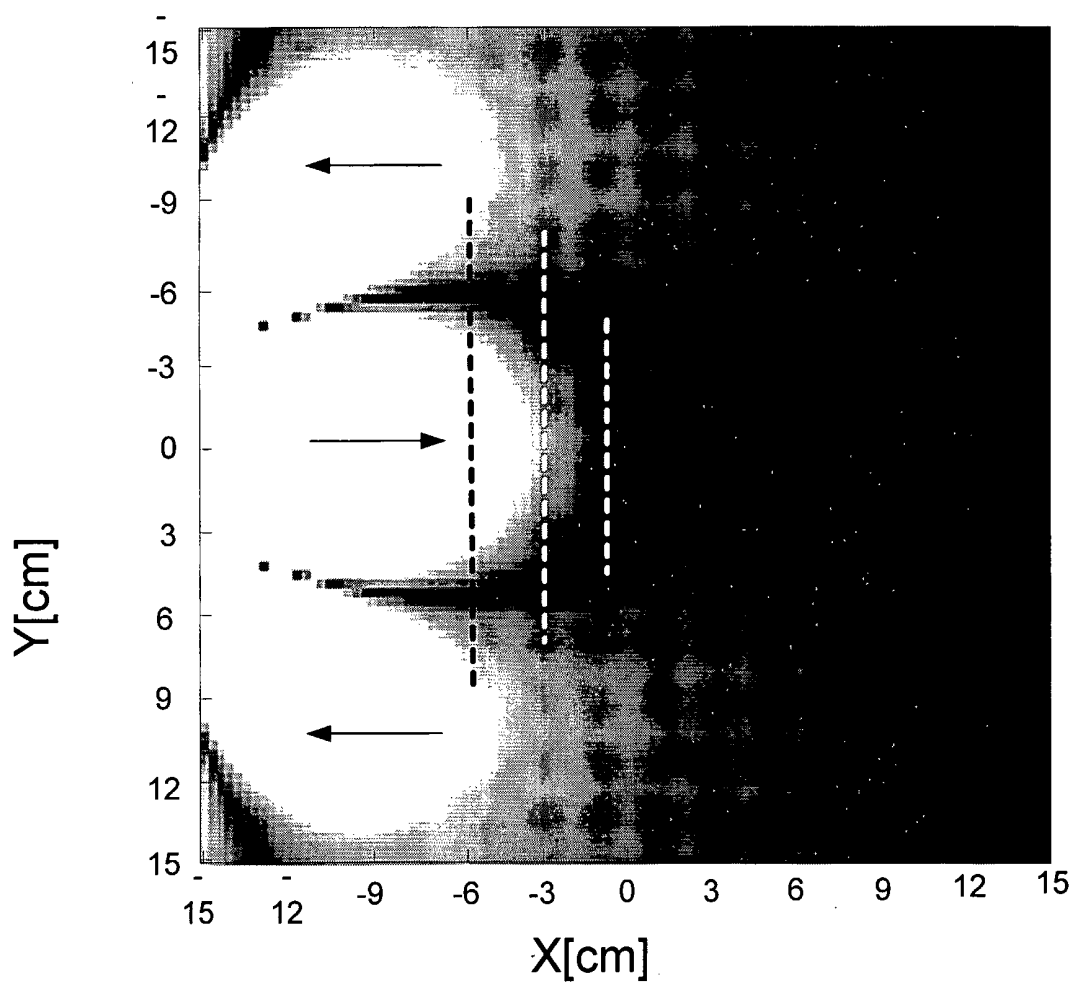

FIG. 16B

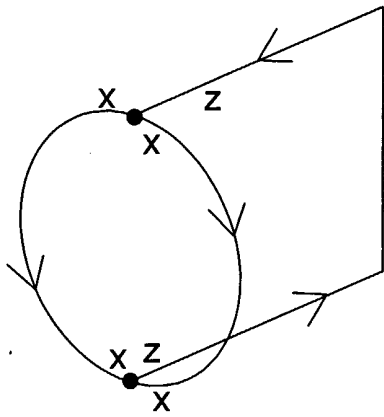

FIG. 17A

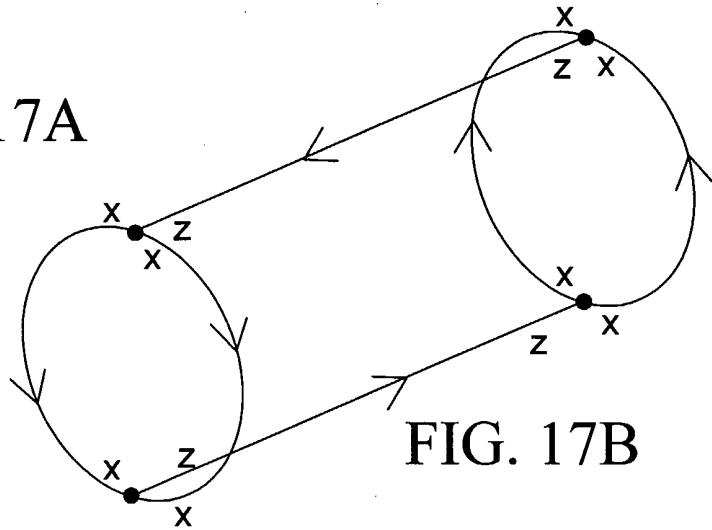

FIG. 17B

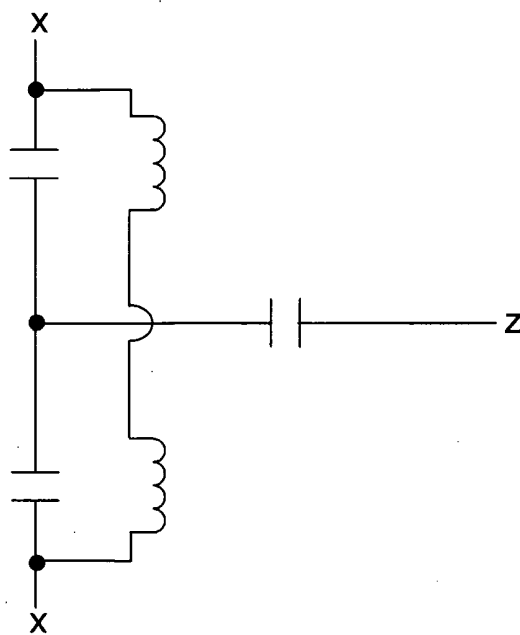

FIG. 18