

(19) World Intellectual Property Organization
International Bureau



(43) International Publication Date
23 February 2006 (23.02.2006)

PCT

(10) International Publication Number
WO 2006/018453 A1

- (51) International Patent Classification⁷: **B60S 1/38**
- (21) International Application Number:
PCT/EP2005/054118
- (22) International Filing Date: 22 August 2005 (22.08.2005)
- (25) Filing Language: English
- (26) Publication Language: English
- (30) Priority Data:
04104008.0 20 August 2004 (20.08.2004) EP
- (71) Applicant (for all designated States except US): **FEDERAL-MOGUL S.A.** [BE/BE]; Avenue Champion, B-6790 AUBANGE (BE).
- (72) Inventors; and
- (75) Inventors/Applicants (for US only): **BOLAND, Xavier** [BE/BE]; 304, Route de Luxembourg, B-6700 ARLON (BE). **ORJELA, Gurdev** [BE/BE]; Federal-Mogul S.A., Avenue Champion, B-6790 AUBANGE (BE).
- (74) Agent: **HOOIVELD, Arjen, Jan, Winfried**; Arnold & Siedsma, Sweelinckplein 1, NL-2517 GK THE HAGUE (NL).
- (81) Designated States (unless otherwise indicated, for every kind of national protection available): AE, AG, AL, AM, AT, AU, AZ, BA, BB, BG, BR, BW, BY, BZ, CA, CH, CN, CO, CR, CU, CZ, DE, DK, DM, DZ, EC, EE, EG, ES, FI, GB, GD, GE, GH, GM, HR, HU, ID, IL, IN, IS, JP, KE, KG, KM, KP, KR, KZ, LC, LK, LR, LS, LT, LU, LV, MA, MD, MG, MK, MN, MW, MX, MZ, NA, NG, NI, NO, NZ, OM, PG, PH, PL, PT, RO, RU, SC, SD, SE, SG, SK, SL, SM, SY, TJ, TM, TN, TR, TT, TZ, UA, UG, US, UZ, VC, VN, YU, ZA, ZM, ZW.
- (84) Designated States (unless otherwise indicated, for every kind of regional protection available): ARIPO (BW, GH, GM, KE, LS, MW, MZ, NA, SD, SL, SZ, TZ, UG, ZM, ZW), Eurasian (AM, AZ, BY, KG, KZ, MD, RU, TJ, TM), European (AT, BE, BG, CH, CY, CZ, DE, DK, EE, ES, FI, FR, GB, GR, HU, IE, IS, IT, LT, LU, LV, MC, NL, PL, PT, RO, SE, SI, SK, TR), OAPI (BF, BJ, CF, CG, CI, CM, GA, GN, GQ, GW, ML, MR, NE, SN, TD, TG).
- Published:**
— with international search report
- For two-letter codes and other abbreviations, refer to the "Guidance Notes on Codes and Abbreviations" appearing at the beginning of each regular issue of the PCT Gazette.

(54) Title: WINDSCREEN WIPER DEVICE

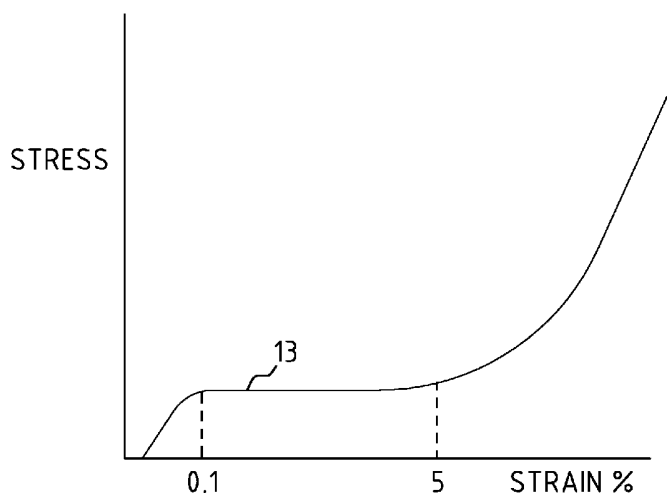

(57) Abstract: A windscreen wiper device (1) comprising elastic, elongated carrier element, as well as an elongated wiper blade (2) of a flexible material, which can be placed in abutment with a windscreen to be wiped, which wiper blade (2) includes opposing longitudinal grooves (9) on its longitudinal sides, in which grooves space-apart longitudinal strips (10) of the carrier element are disposed, which windscreen wiper device (1) further comprises a connecting device (3) for an oscillating arm (4), wherein said oscillating arm (4) is pivotally connected to said connecting device (3) about a pivot axis near one end, with the special feature that said wiper blade (2) and/or said strips (10) are made of a superelastic material such that said wiper blade (2) has a pre-shape with a specific curvature and is deformed when placed in abutment with the windscreen to be wiped, wherein an at least substantially constant force is applied on said windscreen by outer ends of said wiper blade (2), independent of the curvature of said windscreen.

WO 2006/018453 A1

WINDSCREEN WIPER DEVICE

5 The present invention relates to a windscreen wiper device comprising an elastic, elongated carrier element, as well as an elongated wiper blade of a flexible material, which can be placed in abutment with a windscreen to be wiped, which wiper blade includes opposing longitudinal grooves on its
10 longitudinal sides, in which grooves spaced-apart longitudinal strips of the carrier element are disposed, which windscreen wiper device further comprises a connecting device for an oscillating arm, wherein said oscillating arm is pivotally connected to said connecting device about a
15 pivot axis near one end. The invention also refers to a method for manufacturing such a windshield wiper device.

Such a windscreen wiper device is known from German patent publication no. 101 30 903 (Robert Bosch GmbH), for example.

20 The prior art windscreen wiper device is designed as a "yokeless" wiper device, wherein no use is made of several yokes pivotally connected to each other, but wherein the wiper blade is biased by the longitudinal strips, as a result of which it exhibits a specific curvature.

25

A disadvantage of the windscreen wiper device known from the above-mentioned German patent document is the following. The oscillating arm of this prior art windscreen wiper device is pivotally connected to a mounting head fixed for rotation to
30 a shaft driven by a small motor. In use, the shaft rotates alternately in a clockwise and in a counter-clockwise sense carrying the mounting head into rotation also, which in turn draws the oscillating arm into rotation and by means of the connecting device moves the wiper blade. A spring is hooked

with its first end on the mounting head and with its second end on the oscillating arm in order to ensure that the oscillating arm and thus the wiper blade connected thereto is pressed onto the windscreen to be wiped. However, in practice
5 it appears that the oscillating does not press the wiper blade with enough force and/or a constant force (measured along the length of the wiper blade), that is an even pressure onto the windscreen to be wiped, with all negative consequences involved as far as the wiping qualities are
10 concerned.

It is the objective of the present invention to obviate these disadvantages of the prior art, particularly to obtain a windscreen wiper device which has excellent wiping
15 properties.

In order to accomplish that objective a windscreen wiper device of the type mentioned in the introduction to the description according to the invention is characterized in
20 that said wiperblade and/or said strips comprise(s) a superelastic material such that said wiper blade has a pre-shape with a specific curvature and is deformed when placed in abutment with the windscreen to be wiped, wherein an at least substantially constant force is applied on said
25 windscreen by outer ends of said wiper blade, independent of the curvature of said windscreen. In other words, said superelastic wiperblade and/or said superelastic strips ensure(s) that said wiper blade is deformable from an original position when it is not placed against the
30 windscreen to be wiped (for example, when it is packaged in a package, holder or container) into a working position when it is placed against the windscreen to be wiped, and vice versa, in such a manner that

- in the original position the wiper blade exhibits a shape with a predetermined curvature, whereas
- in the working position the wiper blade has a curvature corresponding to the curvature of the windscreen to be wiped, while a constant force is applied on said windscreen by the outer ends of said wiper blade, independent of the specific curvature of said windscreen.

As a specific curvature of the windscreen to be wiped does not negatively influence the wiping qualities of the wiper blade involved, the present wiper blade can be used on almost every type of windscreen. Particularly, said wiper blade and/or said strips is/are made of a superelastic material.

Preferably, a constant force is applied on said windscreen along the entire length of said wiper blade, that is from one outer end to the other outer end of the wiper blade.

In a preferred embodiment of a windscreen wiper device in accordance with the invention the superelastic material comprises nickel and titanium. Preferably, the superelastic material further comprises at least one third element selected from the group consisting of niobium, hafnium, tantalum, tungsten and gold. In the alternative, said superelastic material may (also) comprise copper (or an alloy thereof) and/or iron (or an alloy thereof).

In another preferred embodiment of a windscreen wiper device according to the invention the stress/strain curve of the superelastic material exhibits a loading plateau, wherein an increase in strain over a range of strain varying between 0,1 and 8%, preferably between 0,1 and 5%, is accompanied by an

at least substantially constant stress at the location of said loading plateau.

The invention also refers to a method for manufacturing a
5 windscreen wiper device provided with an elastic elongated
carrier element, as well as an elongated wiper blade of a
flexible material, which can be placed in abutment with a
windscreen to be wiped, which wiper blade includes opposing
longitudinal grooves on its longitudinal sides, in which
10 grooves spaced-apart longitudinal strips of the carrier
element are disposed, which windscreen wiper device further
comprises a connecting device for an oscillating arm, wherein
said oscillating arm is pivotally connected to said
connecting device about a pivot axis near one end,
15 characterized in that said wiper blade and/or said strips
comprise(s) a superelastic material such that said wiper
blade has a pre-shape with a specific curvature and is
deformed when placed in abutment with the windscreen to be
wiped, wherein an at least substantially constant force is
20 applied on said windscreen by outer ends of said wiper blade,
independent of the curvature of said windscreen.

The above and further aspects of the present invention will
now be further explained in more detail with reference to
25 figures illustrated in a drawing, wherein:

- Figure 1 is a perspective, schematic view of a preferred
embodiment of a windscreen wiper device according to the
invention;
- 30 - Figure 2 is a detail of a windscreen wiper device of
figure 1; and

- Figure 3 is the stress/strain curve of the superelastic material of the wiper blade used in the windscreen wiper device of figure 1.

5 Figure 1 shows a preferred variant of a windscreen wiper device 1 according to the invention. Said windscreen wiper device is built up of a wiper blade 2, as well as of a connecting device 3 of plastic material for an oscillating arm 4. The oscillating arm 4 comprises a arm member 5
10 pivotally connected to a mounting head 6 fixed for rotation to a shaft 7 driven by a small motor (not shown). In use, the shaft 7 rotates alternately in a clockwise and in a counter-clockwise sense carrying the mounting head 6 into rotation also, which in turn draws the oscillating arm 4 into rotation
15 and by means of the connecting device 3 moves the wiper blade 2. A spring (not shown) is hooked with its first end on the mounting head 6 and with its second end on the arm member 5 in order to ensure that the oscillating arm 4 and thus the wiper blade 2 connected thereto is pressed onto a windscreen
20 to be wiped. A spoiler 8 extending along the entire length of the wiper blade 2 is detachably connected thereto.

Said windscreen wiper device is built up of said elastomeric wiper blade 2, in the longitudinal sides of which opposing
25 longitudinal grooves 9 are formed, and of longitudinal strips 10 made of an superelastic material comprising nickel and titanium, which are fitted in said longitudinal grooves 9. Said strips 10 form a superelastic carrier element for the rubber wiper blade 2, as it were, which is thus biased in a
30 curved position (the curvature in operative position being that of a windscreen to be wiped). Neighbouring ends 11 of strips 10 are interconnected on either side of the windscreen wiper device 1 by means of connecting pieces 12 functioning

as clamping members. In this embodiment, the connecting pieces 12 are separate constructional elements, which may be form-locked ("positive locking" or "having positive fit") as well as force-locked to the ends 11 of strips 10. In another preferred variant, said connecting pieces 12 are in one piece with the strips 10. In the latter case said connecting pieces form transverse bridges for the strips 10, as it were.

With reference to figure 3 said material has a stress/strain curve showing how stress varies with strain during deformation of the wiper blade 2. The curve exhibits a loading plateau 13. At the location of said plateau 9 an increase in strain over a range of strain varying between 0,1% and 5% corresponds with a constant stress. That means that the wiper blade 2 is able to follow any curvature of a windscreen to be wiped, while the oscillating arm 4 exerts a constant pressure measured along the entire length of the wiper blade on the windscreen to be wiped.

The scope of protection conferred by the present invention is not restricted to the embodiment shown in the figures, but also extends to other embodiments falling within the scope of the appended claims.

CLAIMS

1. A windscreen wiper device comprising an elastic,
elongated carrier element, as well as an elongated wiper
5 blade of a flexible material, which can be placed in
abutment with a windscreen to be wiped, which wiper blade
includes opposing longitudinal grooves on its
longitudinal sides, in which grooves spaced-apart
longitudinal strips of the carrier element are disposed,
10 which windscreen wiper device further comprises a
connecting device for an oscillating arm, wherein said
oscillating arm is pivotally connected to said connecting
device about a pivot axis near one end, **characterized in**
that said wiper blade and/or said strips comprise(s) a
15 superelastic material such that said wiper blade has a
pre-shape with a specific curvature and is deformed when
placed in abutment with the windscreen to be wiped,
wherein an at least substantially constant force is
applied on said windscreen by outer ends of said wiper
20 blade, independent of the curvature of said windscreen.
2. A windscreen wiper device according to claim 1, wherein
the superelastic material comprises nickel and titanium
or an alloy thereof.
25
3. A windscreen wiper device according to claim 2, wherein
the superelastic material further comprises at least one
third element selected from the group consisting of
niobium, hafnium, tantalum, tungsten and gold.
30
4. A windscreen wiper device according to claim 1, 2 or 3,
wherein the superelastic material comprises copper or an
alloy thereof.

5. A windscreen wiper device according to any of the preceding claims 1 through 4, wherein the superelastic material comprises iron or an alloy thereof.

5

6. A windscreen wiper device according to any of the preceding claims 1 through 5, wherein the stress/strain curve of the superelastic material exhibits a loading plateau, and wherein an increase in strain over a range of strain varying between 0,1 and 8%, preferably between 0,1 and 5%, is accompanied by an at least substantially constant stress at the location of said loading plateau.

7. Method for manufacturing a windscreen wiper device provided with an elastic, elongated carrier element, as well as an elongated wiper blade of a flexible material, which can be placed in abutment with a windscreen to be wiped, which wiper blade includes opposing longitudinal grooves on its longitudinal sides, in which grooves spaced-apart longitudinal strips of the carrier element are disposed, which windscreen wiper device further comprises a connecting device for an oscillating arm, wherein said oscillating arm is pivotally connected to said connecting device about a pivot axis near one end, **characterized in that** said wiper blade and/or said strips blade comprise(s) a superelastic material such that said wiper blade has a pre-shape with a specific curvature and is deformed when placed in abutment with the windscreen to be wiped, wherein an at least substantially constant force is applied on said windscreen by outer ends of said wiper blade, independent of the curvature of said windscreen.

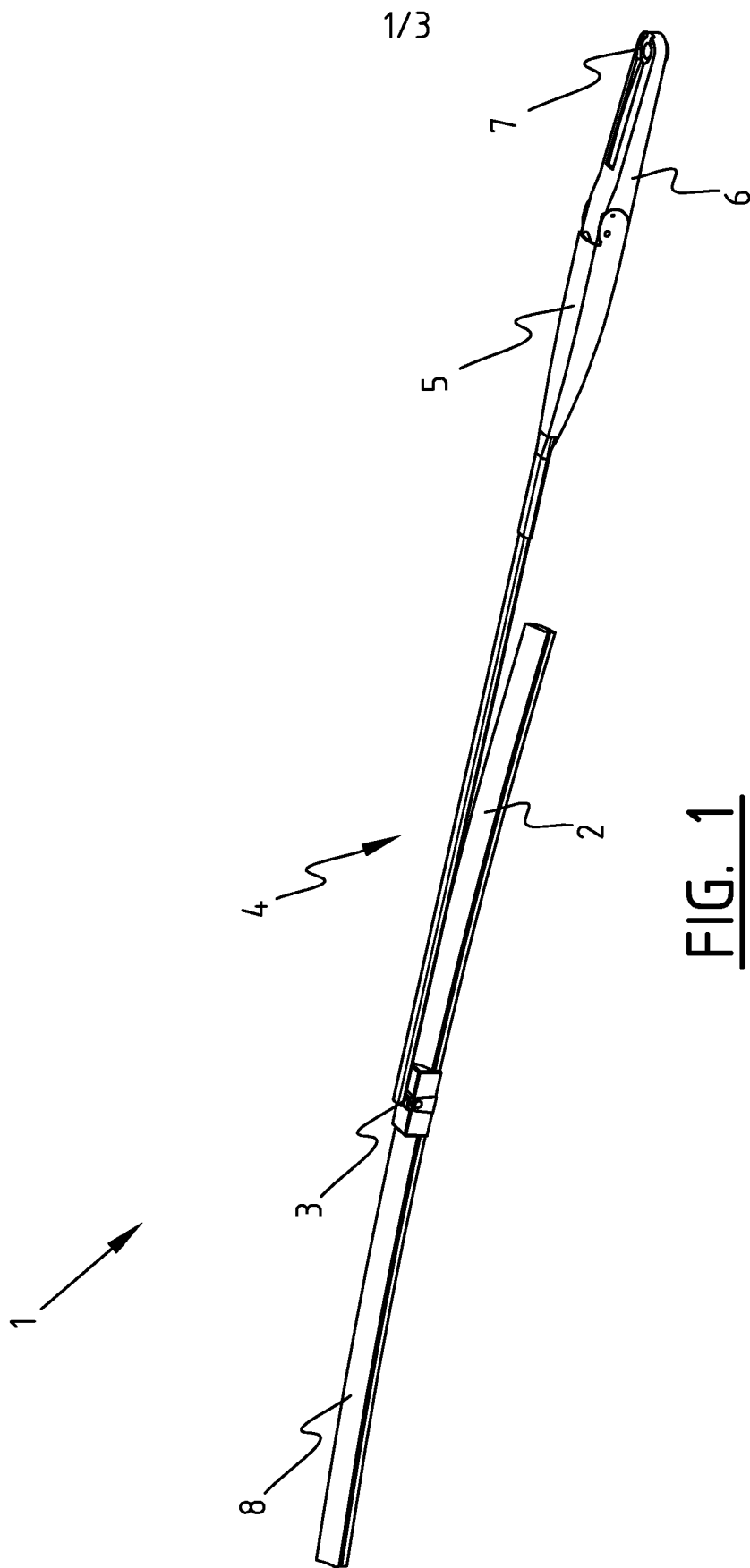

2/3

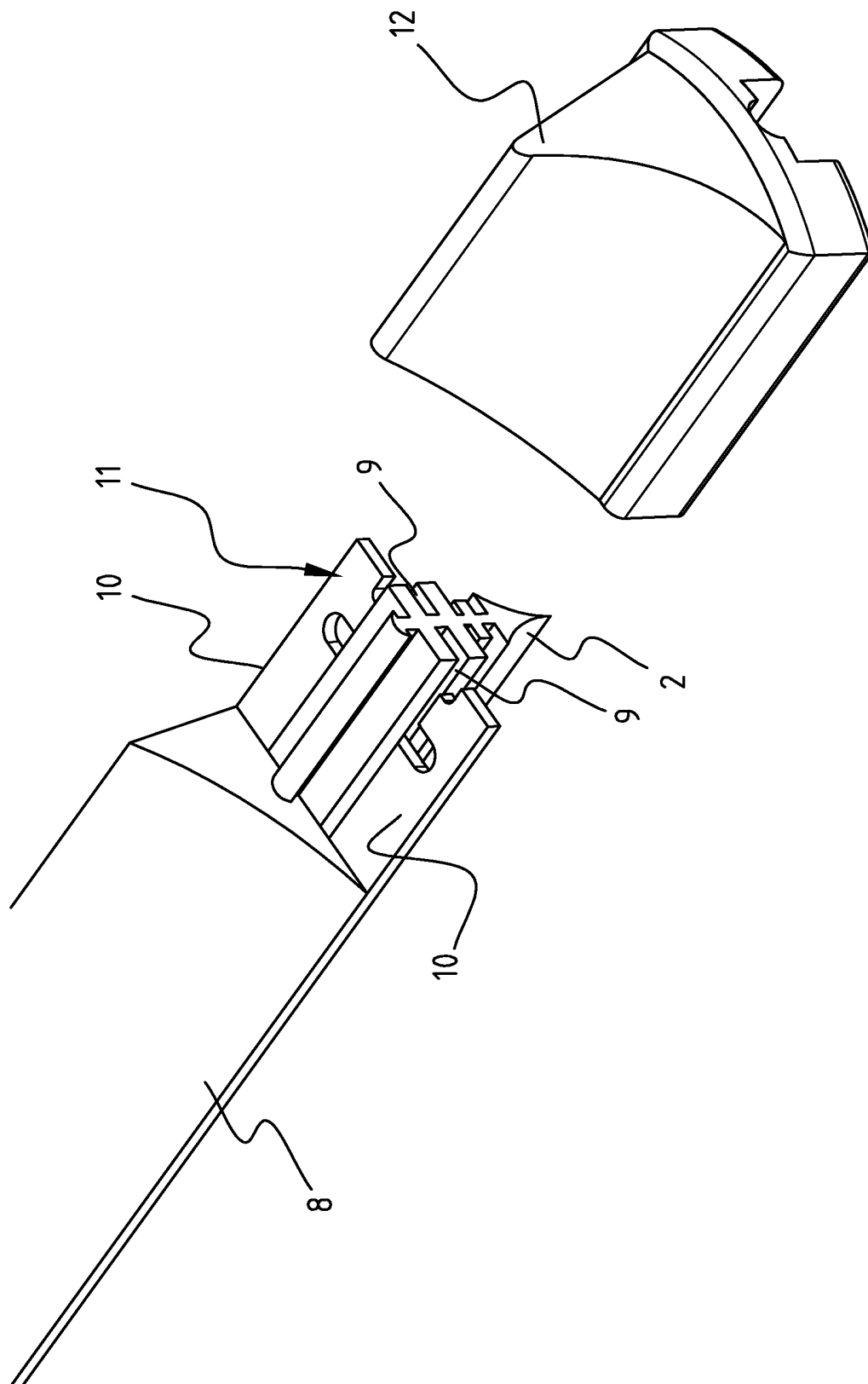

FIG. 2

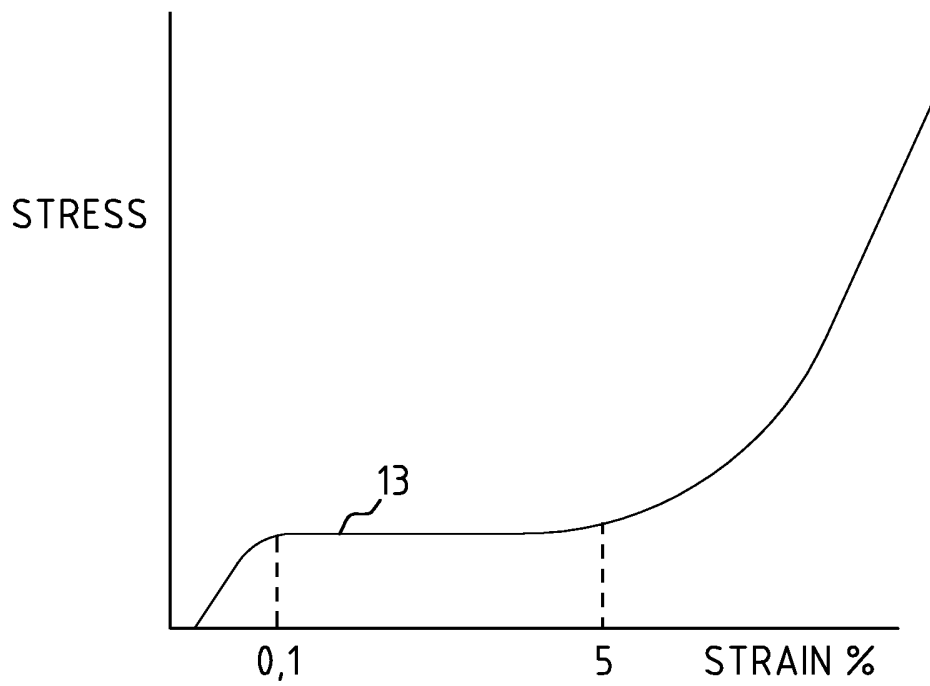

FIG. 3

INTERNATIONAL SEARCH REPORT

International Application No
PCT/EP2005/054118

A. CLASSIFICATION OF SUBJECT MATTER
IPC 7 B60S1/38

According to International Patent Classification (IPC) or to both national classification and IPC

B. FIELDS SEARCHED

Minimum documentation searched (classification system followed by classification symbols)
IPC 7 B60S

Documentation searched other than minimum documentation to the extent that such documents are included in the fields searched

Electronic data base consulted during the international search (name of data base and, where practical, search terms used)

EPO-Internal, PAJ

C. DOCUMENTS CONSIDERED TO BE RELEVANT

Category °	Citation of document, with indication, where appropriate, of the relevant passages	Relevant to claim No.
A	DE 100 15 294 A (DAIMLER CHRYSLER AG) 11 October 2001 (2001-10-11) abstract; figures -----	1-7
A	WO 2004/018271 A (PACHER OSKAR ; KLOSS-ULITZKA GISBERT (DE); CASTRO VICTOR (DE); STAHLWE) 4 March 2004 (2004-03-04) the whole document -----	1-7
A	US 2004/025280 A1 (DE BLOCK PETER ET AL) 12 February 2004 (2004-02-12) page 1, paragraph 5 - page 2, paragraph 10 page 2, paragraph 13 - page 3, paragraph 26 ----- -/--	1, 3, 5-7

Further documents are listed in the continuation of box C.

Patent family members are listed in annex.

° Special categories of cited documents:

- *A* document defining the general state of the art which is not considered to be of particular relevance
- *E* earlier document but published on or after the international filing date
- *L* document which may throw doubts on priority claim(s) or which is cited to establish the publication date of another citation or other special reason (as specified)
- *O* document referring to an oral disclosure, use, exhibition or other means
- *P* document published prior to the international filing date but later than the priority date claimed

- *T* later document published after the international filing date or priority date and not in conflict with the application but cited to understand the principle or theory underlying the invention
- *X* document of particular relevance; the claimed invention cannot be considered novel or cannot be considered to involve an inventive step when the document is taken alone
- *Y* document of particular relevance; the claimed invention cannot be considered to involve an inventive step when the document is combined with one or more other such documents, such combination being obvious to a person skilled in the art.
- *&* document member of the same patent family

Date of the actual completion of the international search

7 November 2005

Date of mailing of the international search report

15/11/2005

Name and mailing address of the ISA
European Patent Office, P.B. 5818 Patentlaan 2
NL - 2280 HV Rijswijk
Tel. (+31-70) 340-2040, Tx. 31 651 epo nl,
Fax: (+31-70) 340-3016

Authorized officer

Sangiorgi, M

1

INTERNATIONAL SEARCH REPORT

International Application No
PCT/EP2005/054118

C.(Continuation) DOCUMENTS CONSIDERED TO BE RELEVANT		
Category °	Citation of document, with indication, where appropriate, of the relevant passages	Relevant to claim No.
A	PATENT ABSTRACTS OF JAPAN vol. 018, no. 201 (C-1188), 8 April 1994 (1994-04-08) -& JP 06 002059 A (FURUKAWA ELECTRIC CO LTD:THE), 11 January 1994 (1994-01-11) abstract; figures -----	1-7
A	US 2002/152668 A1 (LYBARGER MICHAEL A) 24 October 2002 (2002-10-24) abstract; figures -----	1-7
A	US 5 514 076 A (LEY TIMOTHY J) 7 May 1996 (1996-05-07) abstract; figures -----	1-7

INTERNATIONAL SEARCH REPORT

Information on patent family members

International Application No PCT/EP2005/054118

Patent document cited in search report	A	Publication date	Patent family member(s)	Publication date
DE 10015294	A	11-10-2001	NONE	
WO 2004018271	A	04-03-2004	AU 2003255455 A1 EP 1528995 A1	11-03-2004 11-05-2005
US 2004025280	A1	12-02-2004	WO 02076798 A1 DE 10113657 A1 DE 10291197 D2 EP 1373034 A1 JP 2004518579 T	03-10-2002 26-09-2002 15-04-2004 02-01-2004 24-06-2004
JP 06002059	A	11-01-1994	NONE	
US 2002152668	A1	24-10-2002	CN 1395824 A JP 2002315478 A	12-02-2003 29-10-2002
US 5514076	A	07-05-1996	NONE	