

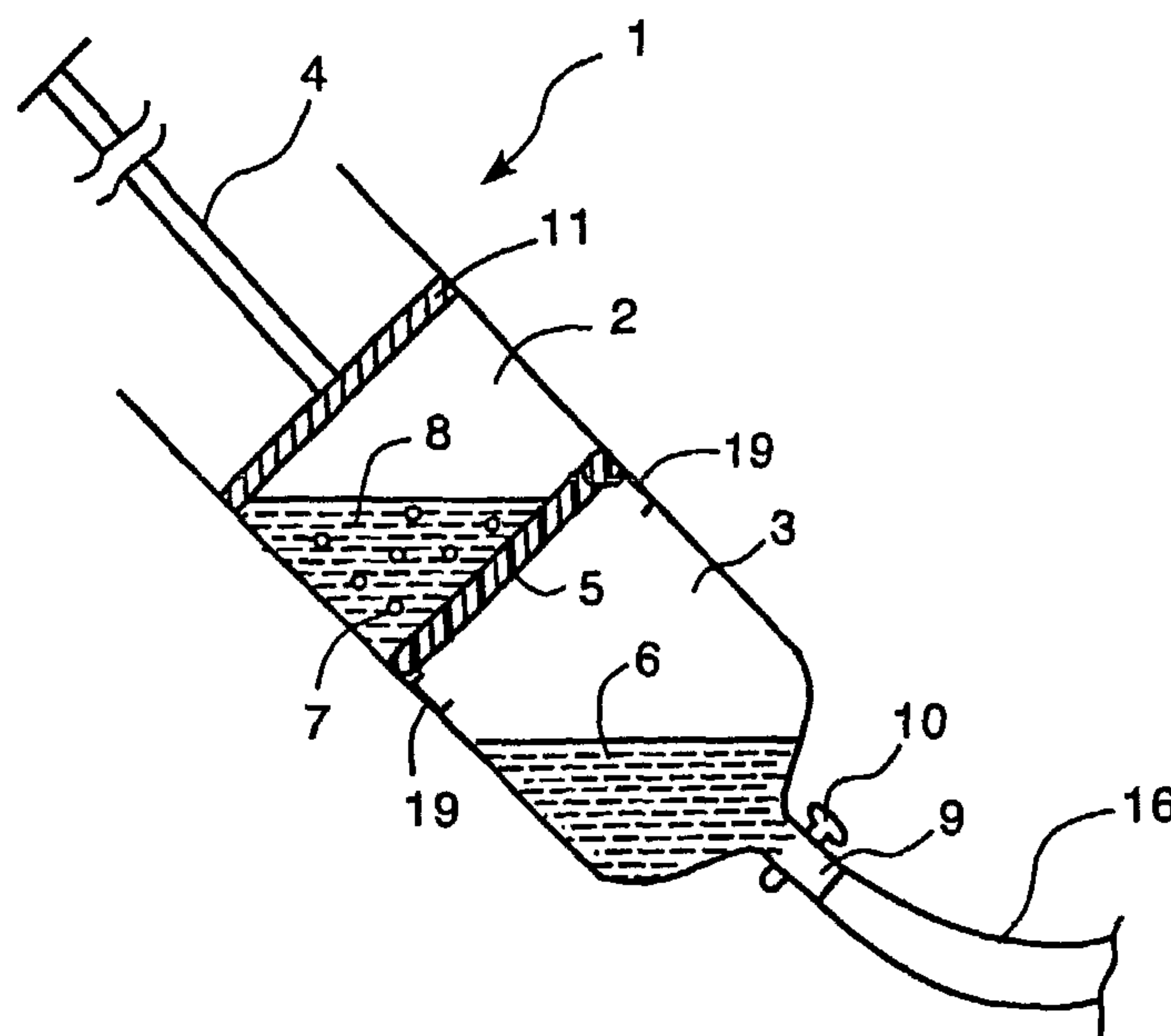

(86) Date de dépôt PCT/PCT Filing Date: 2003/10/22
 (87) Date publication PCT/PCT Publication Date: 2004/05/06
 (85) Entrée phase nationale/National Entry: 2005/04/20
 (86) N° demande PCT/PCT Application No.: US 2003/033674
 (87) N° publication PCT/PCT Publication No.: 2004/037326
 (30) Priorité/Priority: 2002/10/23 (10/278,248) US

(51) Cl.Int.⁷/Int.Cl.⁷ A61M 5/28, A61M 5/31, A61M 5/19
 (71) Demandeur/Applicant:
 BOSTON SCIENTIFIC LIMITED, BB
 (72) Inventeurs/Inventors:
 CASEY, THOMAS V., II, US;
 DAMIANO, BUD, US
 (74) Agent: SMART & BIGGAR

(54) Titre : MELANGE ET ADMINISTRATION DE COMPOSITIONS THERAPEUTIQUES
 (54) Title: MIXING AND DELIVERY MEDICAL SYRINGE SYSTEM FOR THERAPEUTIC COMPOSITIONS



(57) **Abrégé/Abstract:**

In one aspect the invention features a mixing and delivery medical syringe system including a barrel with first and second detachable sections, and first and second compartments communicable through a conduit. In another aspect the invention feature a mixing and delivery medical syringe system including a barrel having first and second compartments arranged in a parallel along the barrel, the compartments communicable through a pressure activated conduit. In still another aspect, the invention features a kit for medicant mixing and delivery, including a syringe system, which includes a barrel assembled from multiple sections, including a first section having a first chamber, and a second section having a second chamber. The syringe system includes a conduit between the first and second chambers through which flow can be controlled. The kit further includes a first container containing a first composition, and a second container containing a second composition.

(12) INTERNATIONAL APPLICATION PUBLISHED UNDER THE PATENT COOPERATION TREATY (PCT)

(19) World Intellectual Property
Organization
International Bureau



(43) International Publication Date
6 May 2004 (06.05.2004)

PCT

(10) International Publication Number
WO 2004/037326 A3

(51) International Patent Classification⁷: **A61M 5/28**,
5/19, 5/31

DE, DK, DM, EC, EE, EG, ES, FI, GB, GD, GE, GH, GM, HR, HU, ID, IL, IN, IS, JP, KE, KG, KP, KR, KZ, LC, LK, LR, LS, LT, LU, LV, MA, MD, MG, MK, MN, MW, MX, MZ, NI, NO, NZ, OM, PG, PH, PL, PT, RO, RU, SC, SD, SE, SG, SK, SL, SY, TJ, TM, TN, TR, TT, TZ, UA, UG, UZ, VC, VN, YU, ZA, ZM, ZW.

(21) International Application Number:
PCT/US2003/033674

(22) International Filing Date: 22 October 2003 (22.10.2003)

(25) Filing Language: English

(26) Publication Language: English

(30) Priority Data:
10/278,248 23 October 2002 (23.10.2002) US

(84) Designated States (*regional*): ARIPO patent (GH, GM, KE, LS, MW, MZ, SD, SL, SZ, TZ, UG, ZM, ZW), Eurasian patent (AM, AZ, BY, KG, KZ, MD, RU, TJ, TM), European patent (AT, BE, BG, CH, CY, CZ, DE, DK, EE, ES, FI, FR, GB, GR, HU, IE, IT, LU, MC, NL, PT, RO, SE, SI, SK, TR), OAPI patent (BF, BJ, CF, CG, CI, CM, GA, GN, GQ, GW, ML, MR, NE, SN, TD, TG).

(71) Applicant: SCIMED LIFE SYSTEMS, INC. [US/US];
One SciMed Place, Maple Grove, MN 55311-1566 (US).

Published:

- with international search report
- before the expiration of the time limit for amending the claims and to be republished in the event of receipt of amendments

(72) Inventors: CASEY, Thomas, V., II; 67 Sunrise Avenue,
Grafton, MA 01519 (US). DAMIANO, Bud; 68 Oakmont
Avenue, Westminster, MA 01473 (US).

(74) Agent: GAGEL, John, J.; Fish & Richardson P.C., 225
Franklin Street, Boston, MA 02110-2804 (US).

(88) Date of publication of the international search report:
23 December 2004

(81) Designated States (*national*): AE, AL, AM, AT, AU, AZ,
BA, BB, BG, BR, BY, BZ, CA, CH, CN, CO, CR, CU, CZ,

For two-letter codes and other abbreviations, refer to the "Guidance Notes on Codes and Abbreviations" appearing at the beginning of each regular issue of the PCT Gazette.

(54) Title: MIXING AND DELIVERY MEDICAL SYRINGE SYSTEM FOR THERAPEUTIC COMPOSITIONS

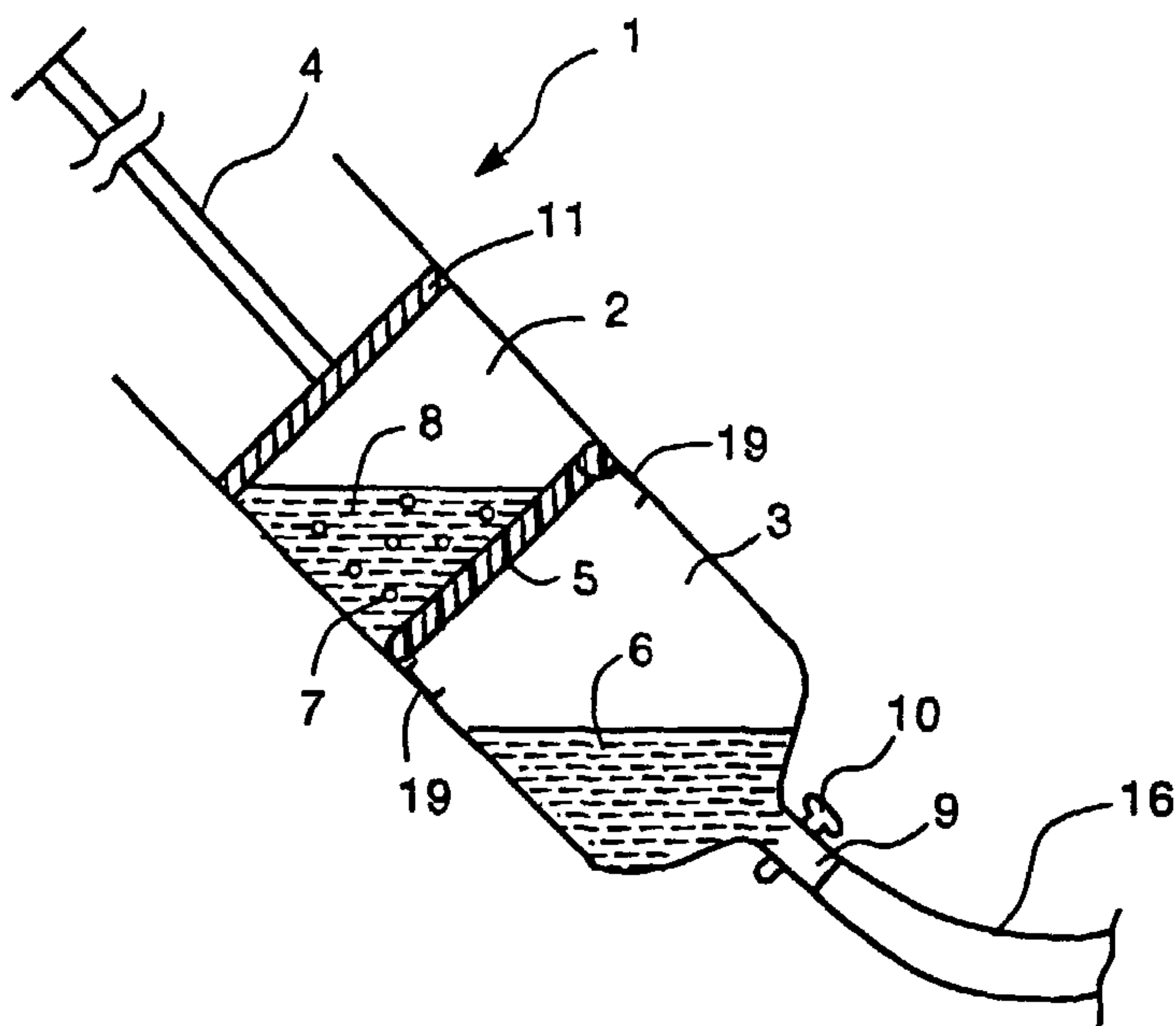

(57) Abstract: In one aspect the invention features a mixing and delivery medical syringe system including a barrel with first and second detachable sections, and first and second compartments communicable through a conduit. In another aspect the invention feature a mixing and delivery medical syringe system including a barrel having first and second compartments arranged in parallel along the barrel, the compartments communicable through a pressure activated conduit. In still another aspect, the invention features a kit for medicant mixing and delivery, including a syringe system, which includes a barrel assembled from multiple sections, including a first section having a first chamber, and a second section having a second chamber. The syringe system includes a conduit between the first and second chambers through which flow can be controlled. The kit further includes a first container containing a first composition, and a second container containing a second composition.

WO 2004/037326 A3

MIXING AND DELIVERY OF THERAPEUTIC COMPOSITIONS

TECHNICAL FIELD

This invention relates to mixing and delivery of therapeutic compositions.

BACKGROUND

Therapeutic vascular occlusions (embolizations) are induced by the introduction of various substances (embolic material, such as embolic particles) into a patient's circulatory system for the purpose of occluding vessels, either to arrest or to prevent hemorrhaging or to defunctionalize a structure or an organ. Typically, the components of an embolic composition – embolic particles in hydrating material (such as saline) and contrast agent (used for tracking the path of the embolic particles inside the body) are stored separately and mixed together at the time of injection into the body by the physician.

SUMMARY

In one aspect the invention features a mixing and delivery medical syringe system. The medical syringe system includes a barrel including first and second detachable sections, and first and second compartments communicable through a conduit.

In another aspect the invention feature a mixing and delivery medical syringe system. The medical syringe system includes a barrel having first and second compartments arranged in parallel along the barrel, the compartments communicable through a pressure-activated conduit.

In another aspect, the invention features a kit for medicant mixing and delivery, including a syringe system, which includes a barrel assembled from multiple sections, including a first section having a first chamber, and a second section having a second chamber. The syringe system includes a conduit between the first and second chambers through which flow can be controlled. The kit further includes a first container containing a first composition, and a second container containing a second composition.

In another aspect, the invention features a method for delivering injectable polymer particles by providing a syringe. The syringe includes a first compartment and

a second compartment. A first component including injectable particles is loaded into at least one compartment, and the syringe is actuated to deliver the particles.

Embodiments can include one or more of the following. The conduit can include a pressure-activated separator. The separator can include a failure membrane. The failure membrane can include a weakened region. The weakened region preferentially effects rupture about a central region of the membrane. The weakened region preferentially affects rupture such that an attachment portion is not ruptured. The pressure-activated conduit can include a valve.

The first and the second compartments can be arranged serially along the syringe barrel. The barrel can include a vent valve. The barrel can include a fluid outlet and the outlet can include a valve. The first section can include the first chamber and the second section can include the second chamber. The conduit can be in one of the first or second sections.

The first composition can include injectable polymer particles. The particles can be embolic particles. The second composition can be a contrast agent. Alternatively, the second composition can include an anticancer agent.

The syringe can include a conduit between the compartments. A first component including injectable particles is loaded into at least one compartment and a second component is loaded into the second compartment. The first component and the second component are mixed in the syringe by flowing at least one of the components through the conduit. The second component can include a contrast agent. The second component can include a drug.

The method can include loading a second composition in the second compartment. The second composition can include polymer particles. The first component and second component can be delivered sequentially.

The first component and the second component can include polymer particles of different sizes or alternatively, of different shapes. The first component can include particles that are substantially spherical.

Embodiments may include one or more advantages. For example, pre-mixing the components may be undesirable because the shelf life of the mixed composition may be reduced for e.g., due to chemical interactions between a contrast agent and embolic particles.

The details of one or more embodiments of the invention are set forth in the accompanying drawings and the description below. Other features, aspects, and advantages of the invention will be apparent from the description and drawings, and from the claims.

DESCRIPTION OF DRAWINGS

FIG. 1A is a cross-sectional schematic of a syringe apparatus for mixing and delivery of a composition into the body.

FIG. 1B is an enlarged cross-sectional view showing a failure membrane of the syringe of FIG. 1A.

FIG. 1C is a top view of the failure membrane of the syringe of FIG. 1A.

FIG. 1D illustrates mixing of the components using the syringe of FIG. 1A.

FIG. 1E illustrates delivery of a mixture through a catheter using the syringe of FIG. 1A.

FIG. 2 is a schematic of a kit for mixing and delivery of a composition.

FIG. 3A is a cross-sectional schematic of a syringe apparatus for mixing and delivery of a composition into the body.

FIG. 3B is a top view of a failure membrane of the syringe of FIG. 3A.

FIGS. 3C and 3D illustrate mixing of the components of a composition using the syringe system of FIG. 3A.

FIG. 3E illustrates delivery of a mixture through a catheter using the syringe of FIG. 3A.

FIG. 4A is a cross-sectional schematic of a syringe apparatus for mixing and delivery of a composition into the body.

FIG. 4B illustrates mixing of the components of a composition using the syringe of FIG. 4A.

FIG. 4C illustrates delivery of a composition through a catheter using the syringe of FIG. 4A.

FIG. 4D is a top view of a plunger lock of the syringe of FIG. 4A.

FIG. 5A is a cross-sectional schematic of a syringe apparatus for mixing and delivery of particles of different sizes.

FIG. 5B is a cross-sectional schematic of a syringe apparatus for mixing and delivery of particles of different shapes.

Like reference symbols in the various drawings indicate like elements.

DETAILED DESCRIPTION

Referring to FIG. 1A, a syringe apparatus 1 includes a body with an upper compartment 2, a lower compartment 3, a plunger 4 with a plunger base 11, a membrane 5, and a connector 9, which could be a luer connector, fitted with a stopcock 10. The lower compartment 3 contains a contrast agent 6 and the upper compartment 2 contains a combination of particles such as embolic particles 7 and a hydrating fluid such as saline 8. The upper compartment 2 and lower compartment 3 are fitted together at junction 19. The membrane 5 can be made of a polymer material or of cellulose based materials, such as cellulose acetate, that provides a liquid-tight seal between the upper and lower compartments so that the contrast agent may be isolated from interaction with the embolic material and saline mixture until the time of injection into the body.

Referring to FIGS. 1B and 1C, expanded views of the membrane 5 are illustrated. The membrane 5 has a failure region 13 and a hinge region 14. In one embodiment, the failure and hinge regions can be regions of reduced thickness. The thickness of the failure region 13 is less than the thickness of the hinge region 14 such that the membrane will fail preferentially at the failure region 13 and bend preferentially at the hinge region 14, in response to pressure increase in the upper compartment 2. Referring to FIG. 1C, a top view of the membrane 5 is illustrated showing the failure region 13 extending substantially around most of the circumference of the membrane, and the hinge region 14 extending along a short segment of the circumference. The reduced thickness regions of the membrane can be formed by heating, scoring or laser ablation.

Referring to FIG. 1D, with the stopcock 10 closed, pressure is applied in the upper compartment by depressing the plunger. The applied pressure on the failure membrane 5 causes it to rupture at the failure region 13 and to bend at the hinge region 14. The embolic particles and saline in the upper compartment 2 travel to the lower compartment 3 and mix with the contrast agent to form the mixed embolic composition 15. Because the embolic particles are initially located in the upper compartment and the contrast in the lower compartment, the particles fall into the contrast solution in a

turbulent manner which enhances mixing and the creation of a uniform suspension of the particles in the mixture.

Referring to FIG. 1E, the stopcock 10 is opened to allow the mixed embolic composition 15 to pass via the connector 9, through a catheter 16 for injection into the body (not shown). The plunger can be further lowered to apply pressure for injecting the mixture into the body. In other embodiments, the stopcock 10 can be eliminated where the flow resistance of the syringe outlet and any attached delivery apparatus, such as a catheter, is sufficient to retard flow of solution in response to the pressure in the syringe after rupturing the membrane. The plunger base 11, particularly its circumference, may be made of a flexible rubbery material, such as an elastomeric polymeric material, that can deflect or bend when it engages the membrane so that the plunger can be lowered beyond the membrane into the lower compartment for injection of the mixture into the body.

Referring to FIG. 2, a syringe kit is illustrated. The kit includes a syringe barrel made of two detachable sections, 20 and 22, defining the upper compartment 2 and the lower compartment 3, a plunger 4 with a base 11, a vial 24 of embolic material 7 in saline 8, and a vial 26 of contrast agent 6. The upper section 20 of the syringe apparatus has a female-type connector 21 at its bottom end to fit with a male-type connector 23 at the top of the lower section 22. The connection between the upper and lower sections can be, for example, a pressfit, threaded or luer type connection. The lower section 22 has a connector 9 fitted with a stopcock 10. Failure membrane 5 can be placed between the upper and lower sections or can be preattached to one of the sections; in FIG. 2 the membrane is attached to the upper section. For use, the syringe apparatus is assembled as follows: Stopcock 10 is closed and contrast solution 6 from vial 26 is placed in the lower compartment 3 and the upper section is assembled with the lower section. Embolic material 7 along with saline solution 8 is placed in the upper compartment from vial 24. The plunger 4 is then placed in the upper compartment to complete the syringe assembly. The syringe can be provided commercially as a kit with the compartments preloaded with the appropriate components.

Referring to FIGS. 3A-3E, another embodiment of the syringe apparatus is illustrated. Here the failure membrane 30 is weakened across the center 31, as illustrated in FIG. 3B, for rupture on application of pressure. The rest of the syringe

apparatus is as in the first embodiment illustrated in FIG. 1. Referring to FIG. 3C, the stopcock 10 is closed, and when pressure is applied to the upper compartment by depressing the plunger 4, the base 11 of the plunger conveys the applied pressure onto the failure membrane 30 causing its rupture at the weakened regions 31 (to form leaflets). The contents of the upper compartment 2 travel to the lower compartment 3 and mix with it to form the mixed embolic composition 15. Because the embolic particles are initially located in the upper compartment and the contrast in the lower compartment, the particles fall into the contrast solution in a turbulent manner which enhances mixing and the creation of a uniform suspension of the particles in the mixture. Referring to FIG. 3D, the plunger 4 is withdrawn, which causes the embolic composition 15 to backfill the upper compartment. This causes further mixing of the components of the embolic mixture and also prepares the apparatus for delivery of the embolic composition 15. Referring to FIG. 3E, stopcock 10 is opened and the plunger 4 is depressed to allow the embolic composition 15 to pass through the connector 9 to the catheter 16 for injection into the body (not shown). In other embodiments, the upper or lower compartments, or both upper and lower compartments can include a vent valve on the sidewall, (upper vent valve 33 shown in phantom in FIG. 3A) to enable pressure control within the syringe apparatus.

Referring to FIG. 4A, in another embodiment, a syringe barrel 40 is provided that has parallel compartments, including a left compartment 41 with a plunger 42, and a right compartment 43, with a plunger 44, both plungers 42 and 44 are fitted with a plunger lock 50. The plunger locks 50 prevent accidental deployment of the plungers. An expanded view of the plunger lock is illustrated in FIG. 4D. The plunger lock 50 includes a frame 54 consisting of a stationary vertical strip 56 placed towards one end of the frame and a movable vertical strip 57 placed towards the other end of the frame, with a threaded hole 58 at the center of the strip 57, through which a screw 59 is passed. The space between the two strips 56 and 57 houses the stem of the plunger. In use, to lock the plunger and prevent its deployment, the strip 57 is moved until the stem of the plunger is tightly held between strips 56 and 57. Counterclockwise movement of the screw 59 further secures the plunger tightly between the two strips 56 and 57. To unlock the plunger for deployment, the screw 59 is turned clockwise and the strip 57 is moved away from the plunger which loosens the grip of the two strips 57 and 58 on the stem of the plunger and unlocks the plunger for deployment. The plunger locks can be

made of a metallic or polymeric material. To place the plunger lock 50 on the stem of the plunger, the plunger lock 50 is unlocked, the strip 57 is moved towards the frame, and the lock is slid onto the stem of the plunger from the top and is placed in any desired position on the stem of the plunger.

The compartments are divided by a central divider 45 with a pressure-activated two-way valve 46 at the end of the central divider 45, connecting the two compartments. The pressure-activated valve can include a polymer membrane 47 that can flex into either compartment based on the pressure differential between the compartments. A connector 48, at the bottom of the syringe assembly communicates with both compartments of the syringe and is fitted with a stopcock 49. The left compartment 41 contains the contrast solution 6, and the right compartment 43 contains a mixture of embolic particles 7 and saline solution 8.

Referring to FIG. 4B, the stopcock 49 is closed, the two plunger locks 50 on the left and right plungers 42 and 44 are unlocked, and the right plunger 44 is lowered causing the membrane 47 to flex into the left compartment and the valve 46 to open. Embolic particles and saline travel to the left compartment (arrow) and mix with the contrast solution to form the embolic mixture 15. Further thorough mixing may be achieved by repeated alternate operation of the two plungers, 42 and 44. Referring to Fig 4C, the stopcock 49 is opened, the two plungers 42 and 44 are simultaneously depressed such that the embolic mixture 15 passes via the connector 48 through the catheter 16 for injection into the body (not shown). (Alternatively, the plungers can be depressed sequentially.) In other embodiments, the valve membrane can be a failure membrane.

Referring to FIG. 5A and FIG. 5B, another embodiment of the syringe apparatus is illustrated. In this embodiment, there is no two-way valve connecting the two compartments. The central divider 45 extends up to the connector 48 at the bottom of the syringe assembly. Referring to FIG. 5A, the left and right compartments 41 and 43 contain two different sizes of embolic particles, a smaller size 60, and a larger size 62, mixed with saline and/or contrast agent. Referring to FIG. 5B, the left and right compartments 41 and 43 contain two different shapes, a spherical shape 64, and an irregular shape 66, of embolic particles mixed with saline and or contrast agent. The rest of the syringe apparatus is as in the embodiment described in FIG. 4.

The arrangement allows delivery of two different sizes of embolic particles sequentially or simultaneously by sequential or simultaneous operation of the plungers. For example, smaller particles can be delivered first to travel to smaller diameter vessels, followed by larger particles to occlude vessels of larger diameter, upstream of the small diameter vessels. Alternatively, two different shapes of embolic particles can be delivered sequentially (or simultaneously). For example, spherical particles may be delivered first to aggregate and occlude distal regions and the irregular particles may be delivered second for more proximal aggregation.

In use, embolic particles in saline are disposed in the compartments from the top of the syringe, after removing the plungers. Contrast agent is drawn into each compartment from a supply in communication with the connector 48 by releasing the appropriate plunger lock and withdrawing the appropriate plunger. The syringe can be provided commercially as a kit with the compartments preloaded with the appropriate components. For injection into the body, the embolic composition with the desired embolic particle size and shape is injected into the body by release of the appropriate plunger lock, opening the stopcock 49, and depressing the appropriate plunger.

The mixing and delivery system discussed above can be used to deliver a number of compositions. Suitable embolic particles are polymer particles. Preferred particles are spherical particles formed of polyvinyl alcohol, as discussed in "Embolization", USSN 10/215,594, filed August 9, 2002, the entire contents of which is incorporated herein by reference. A suitable contrast agent is Omnipaque 300 (Nycomed, Buckinghamshire, UK). (Omnipaque is an aqueous solution of iohexol, N.N.-Bis (2,3-dihydroxypropyl)-T-[N-(2,3-dihydroxypropyl)-acetamide]-2,4,6-trilodoisophthalamide; Omnipaque 300 contains 647 mg of iohexol equivalent to 300 mg of organic iodine per ml). The syringe system can be used to premix and deliver other agents. For example, the systems can be used for mixing of drug agents, such as anti-cancer agents, with polymer particles as described in USSN 10/232,265, filed August 30, 2002. The system can be used to premix compositions without particles. A valve, such as in Fig. 4A can be used instead of the failure membrane in Fig. 1A. A membrane can be used that is not pressure-activated. For example, the membrane can be deflected by a control lever operable from outside of the syringe barrel. In another example, a sharpened member can be located on the plunger head that pierces the membrane.

Still further embodiments are in the following claims.

WHAT IS CLAIMED IS:

1. A mixing and delivery medical syringe system, comprising:
a barrel including first and second detachable sections, and first and second compartments communicable through a conduit.
2. The system of claim 1, wherein the conduit includes a pressure-activated separator.
3. The system of claim 2, wherein the separator includes a failure membrane.
4. The system of claim 3, wherein the failure membrane includes a weakened region.
5. The system of claim 4, wherein the weakened region preferentially effects rupture about a center region of the membrane.
6. The system of claim 4 wherein the weakened region preferentially affects rupture such that an attachment portion is not ruptured.
7. The system of claim 1, wherein the pressure-activated conduit includes a valve.
8. The system of claim 1, wherein the first compartment and the second compartment are arranged serially along the barrel.
9. The system of claim 1, wherein the barrel includes a vent valve.
10. The system of claim 1, wherein the barrel includes a fluid outlet and the outlet includes a valve.
11. The system of claim 1, wherein the first section includes the first chamber and the second section includes the second chamber.

12. The system of claim 11, wherein the conduit is in one of the first or second sections.
13. A mixing and delivery medical syringe system including a barrel having first and second compartments arranged in parallel along the barrel, the compartments communicable through a pressure-activated conduit.
14. The system of claim 13 wherein the conduit includes a valve.
15. A kit for medicant mixing and delivery, comprising:
a syringe system including a barrel assembled from multiple sections, including a first section having a first chamber, and a second section having a second chamber, the syringe system including a conduit between the first and second chambers through which flow can be controlled, and
a first container of a first composition, and
a second container of a second composition.
16. The kit of claim 15 wherein the first composition includes injectable polymer particles.
17. The kit of claim 16 wherein the particles are embolic particles.
18. The kit of claims 15 or 16 wherein the second composition is a contrast agent.
19. The kit of claims 15 or 16 wherein the second composition is an anticancer agent.
20. A method for delivering injectable polymer particles, the method comprising:
providing a syringe including a first compartment and a second compartment,

loading a first component including injectable particles into at least one compartment, and

actuating the syringe to deliver said particles.

21. The method of claim 20, the method comprising:
providing a syringe including a conduit between said compartments, and
loading a second component into said second compartment, and
mixing said first component and said second component in the syringe by
flowing at least one of said components through said conduit.

22. The method of claim 21, wherein said second component includes contrast agent.

23. The method of claim 21, wherein said second component includes a drug.

24. The method of claim 20, the method comprising loading a second composition in said second compartment, said second composition including polymer particles and

delivering said first component and second component sequentially.

25. The method of claim 24, wherein the first and second components include polymer particles of different sizes.

26. The method of claim 24, wherein the first and second components include polymer particles of different shapes.

27. The method of claim 26, wherein the first component includes particles that are substantially spherical.

FIG. 1A

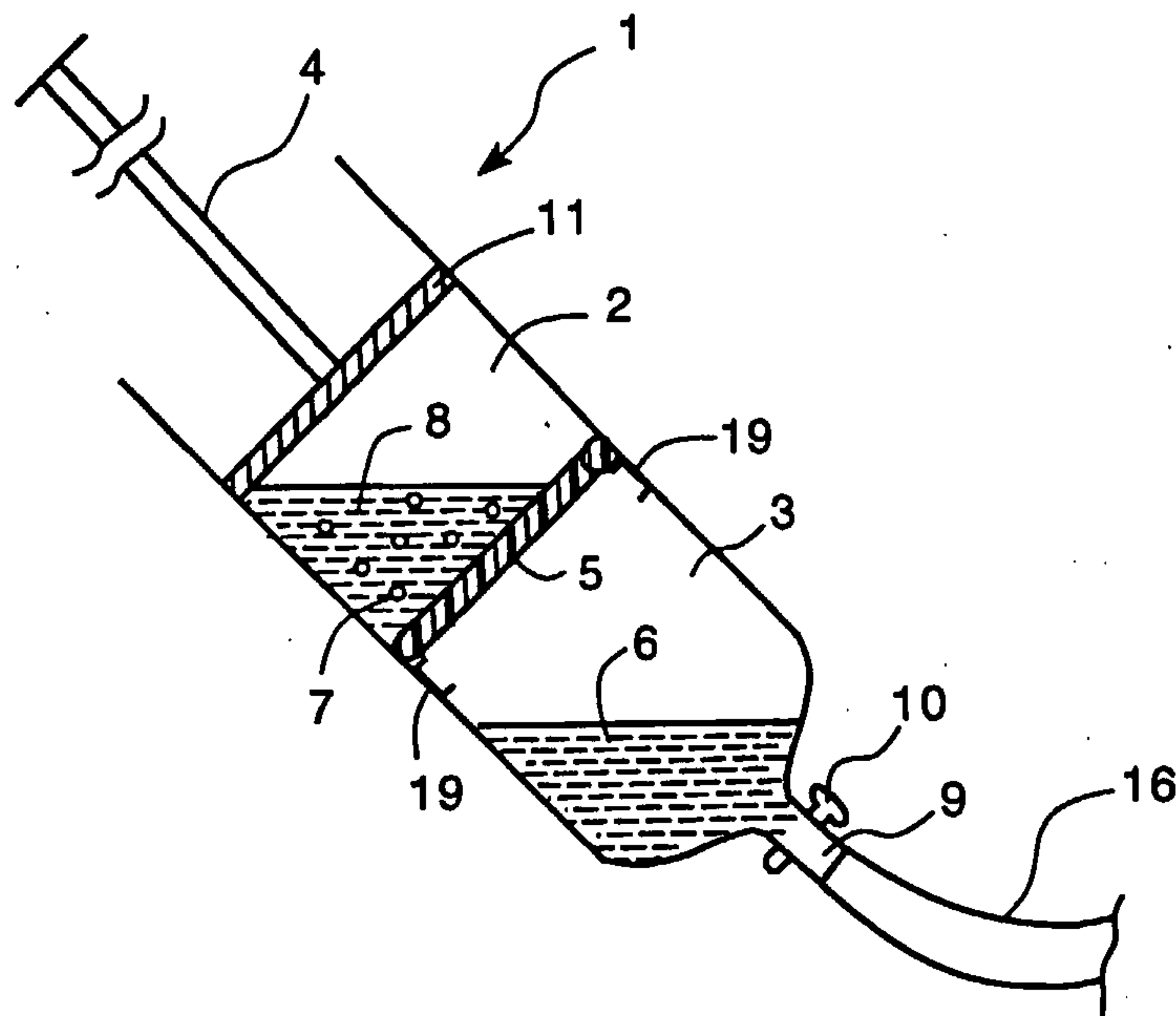

FIG. 1B

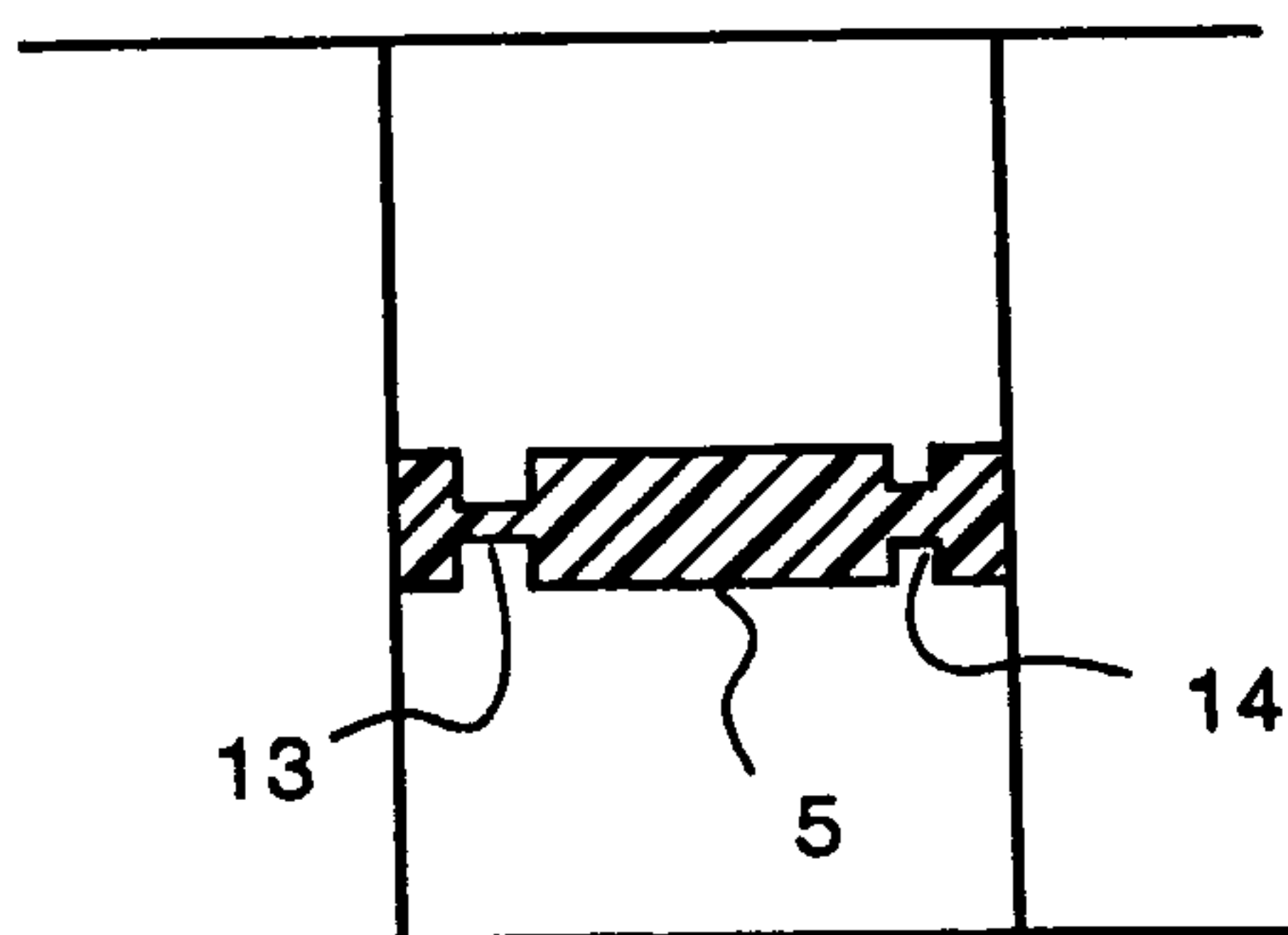

FIG. 1C

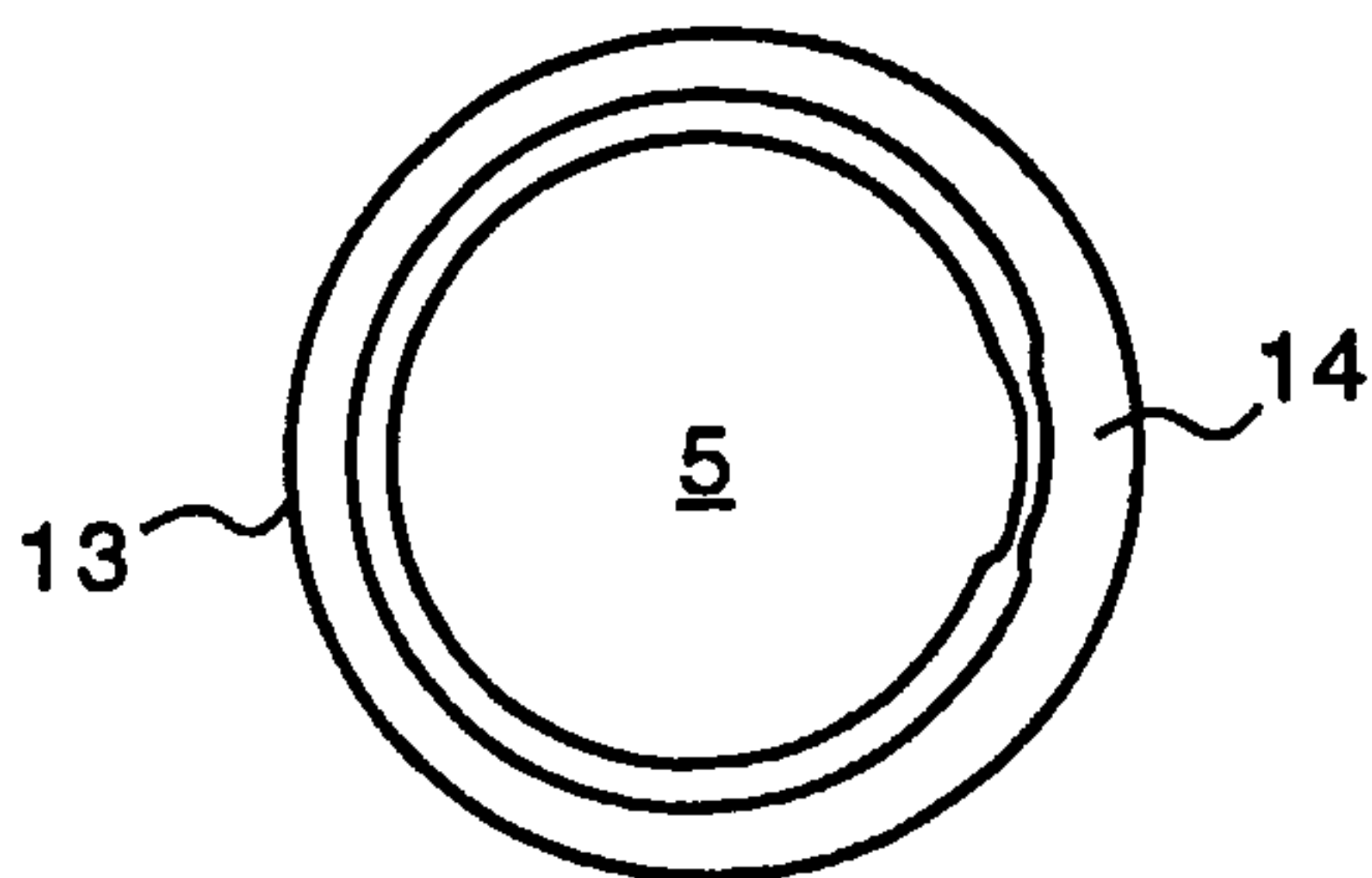

FIG. 1D

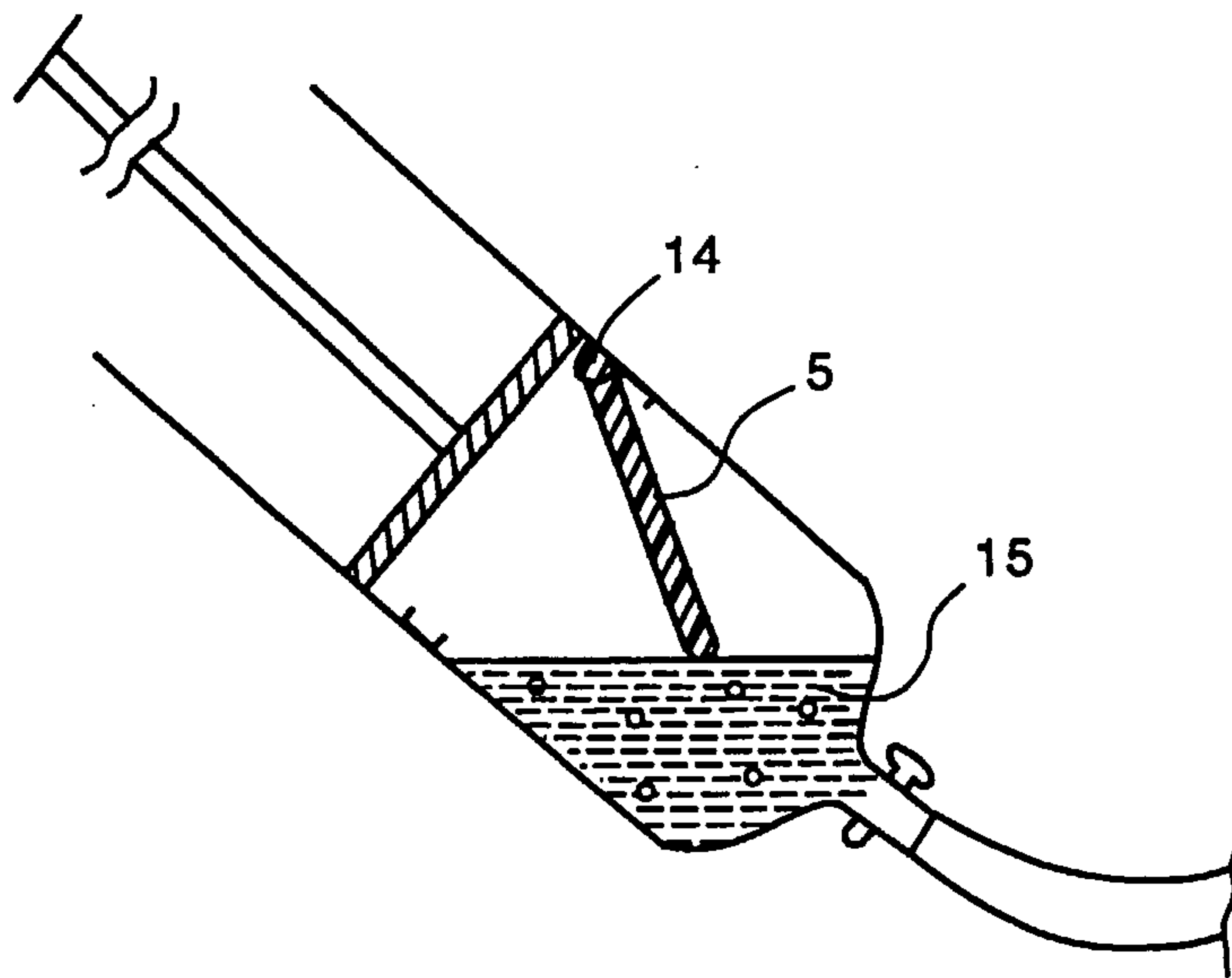

FIG. 1E

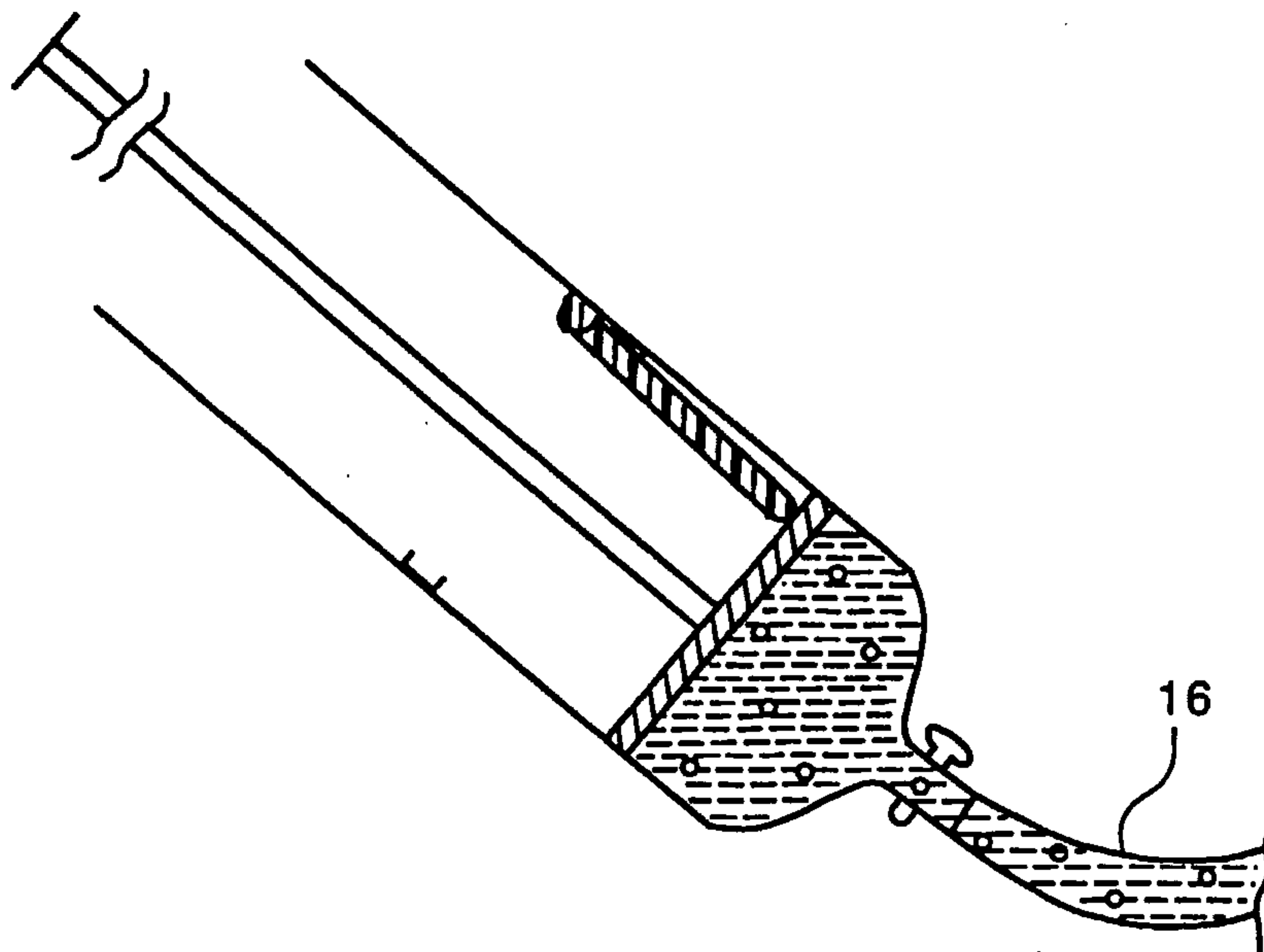

FIG. 2

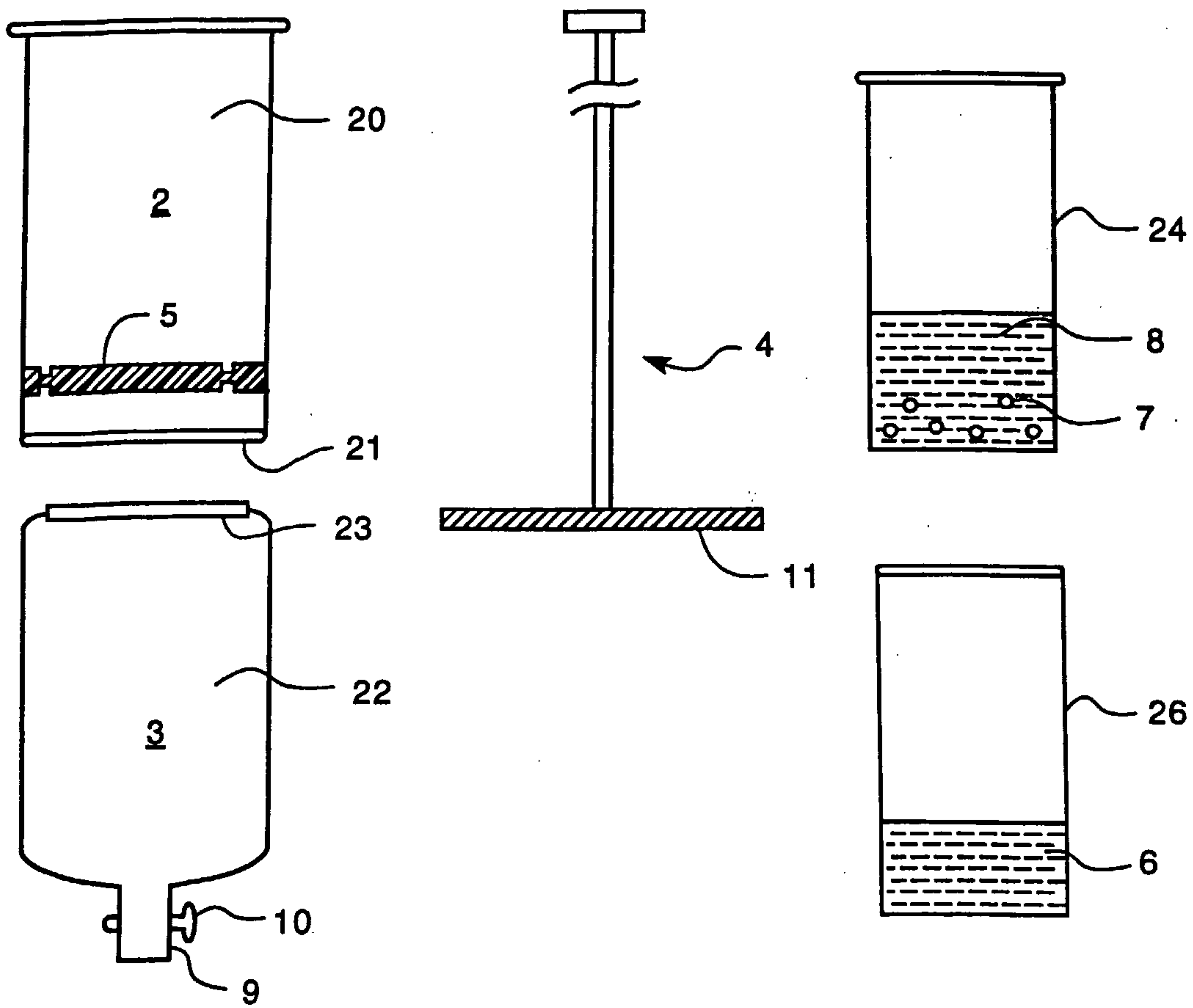

FIG. 3A

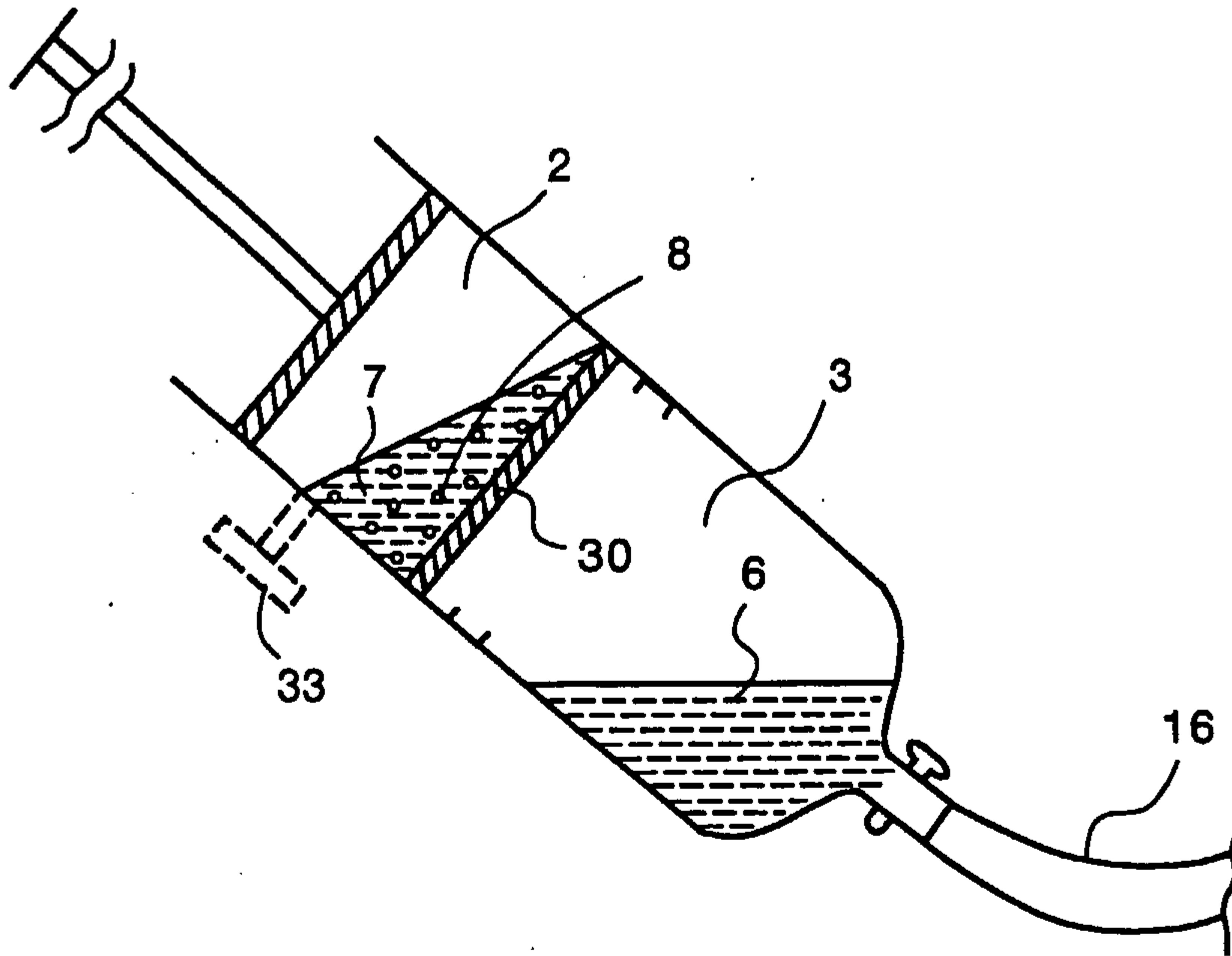

FIG. 3B

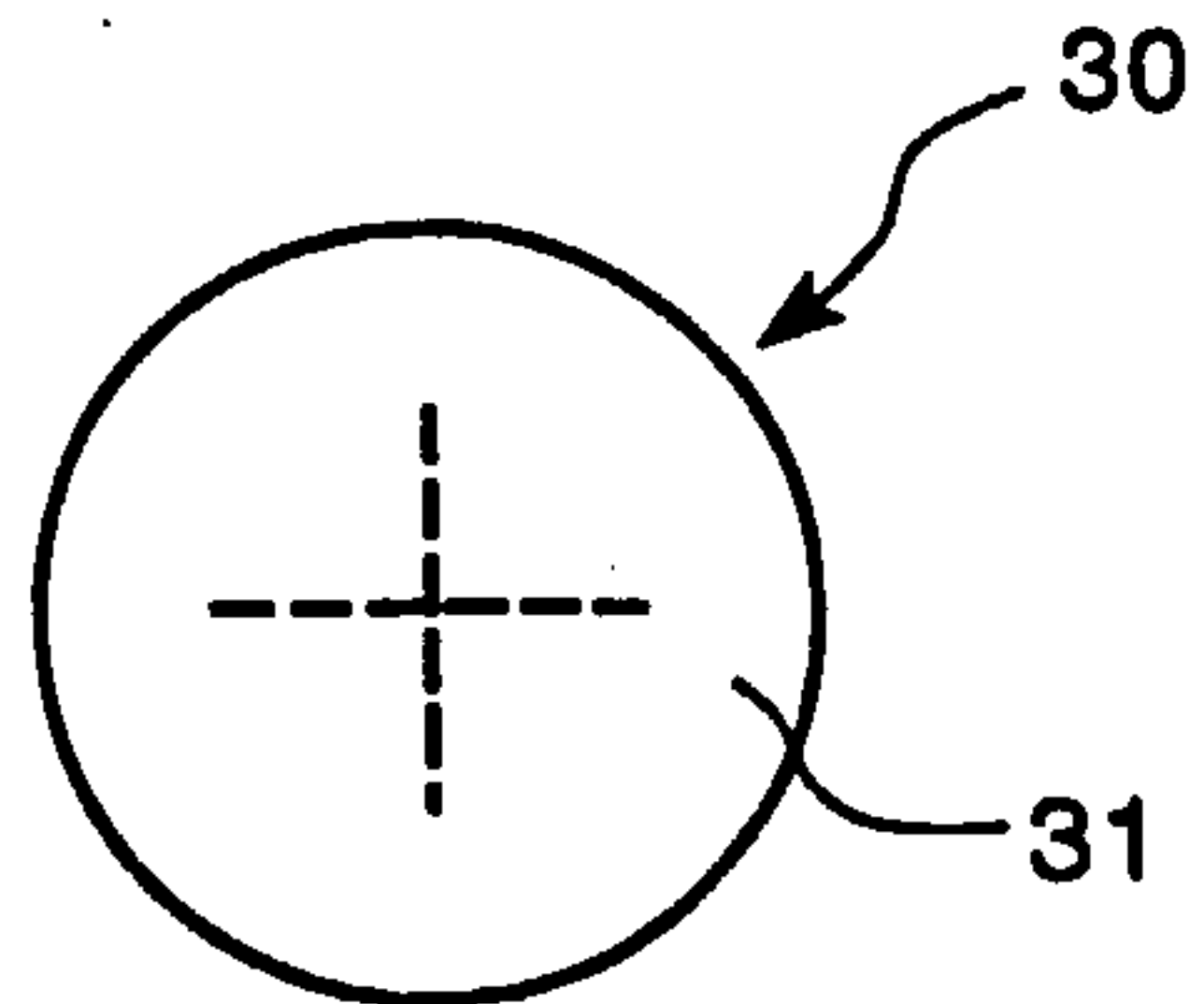

FIG. 3C

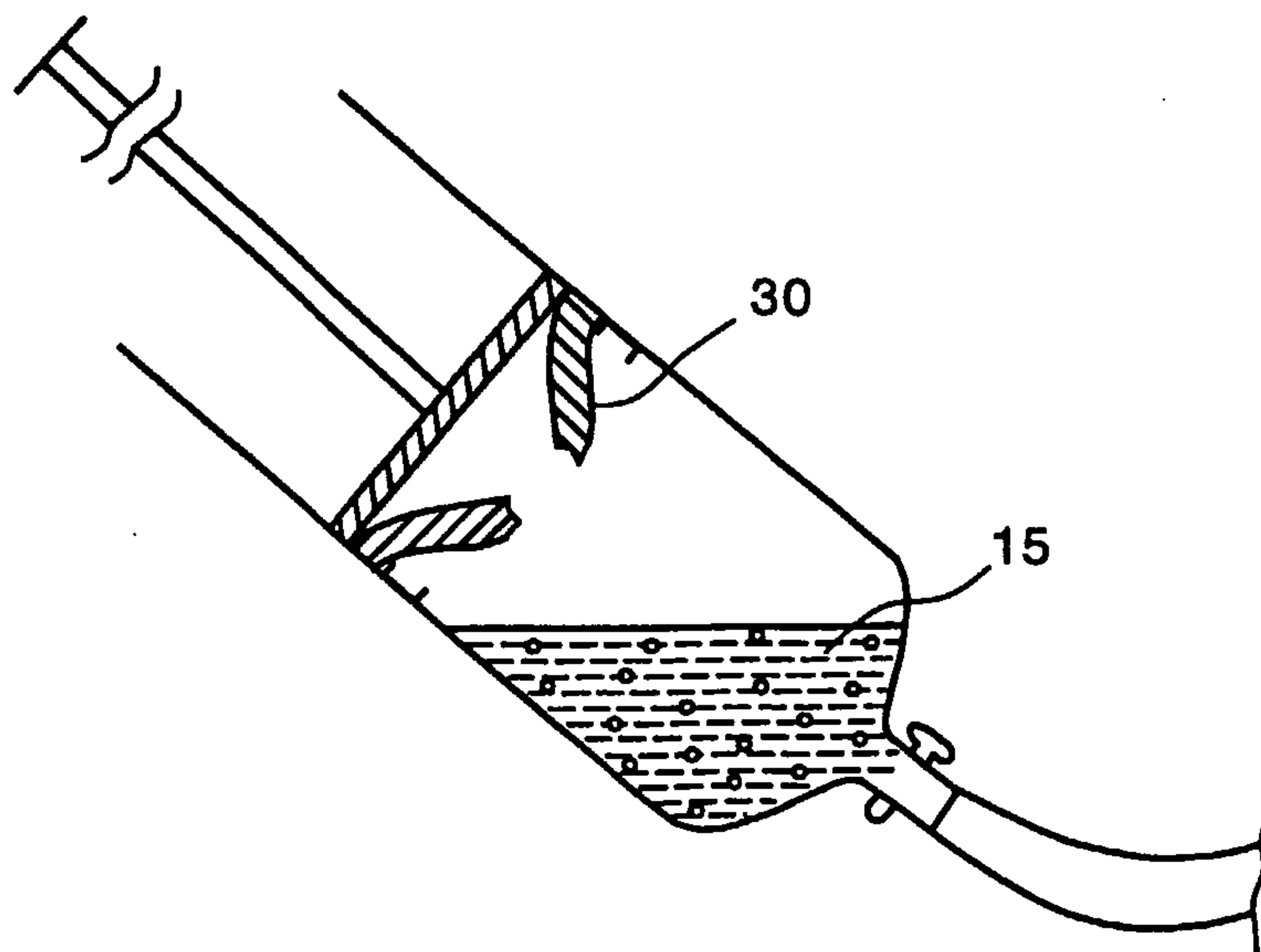

FIG. 3D

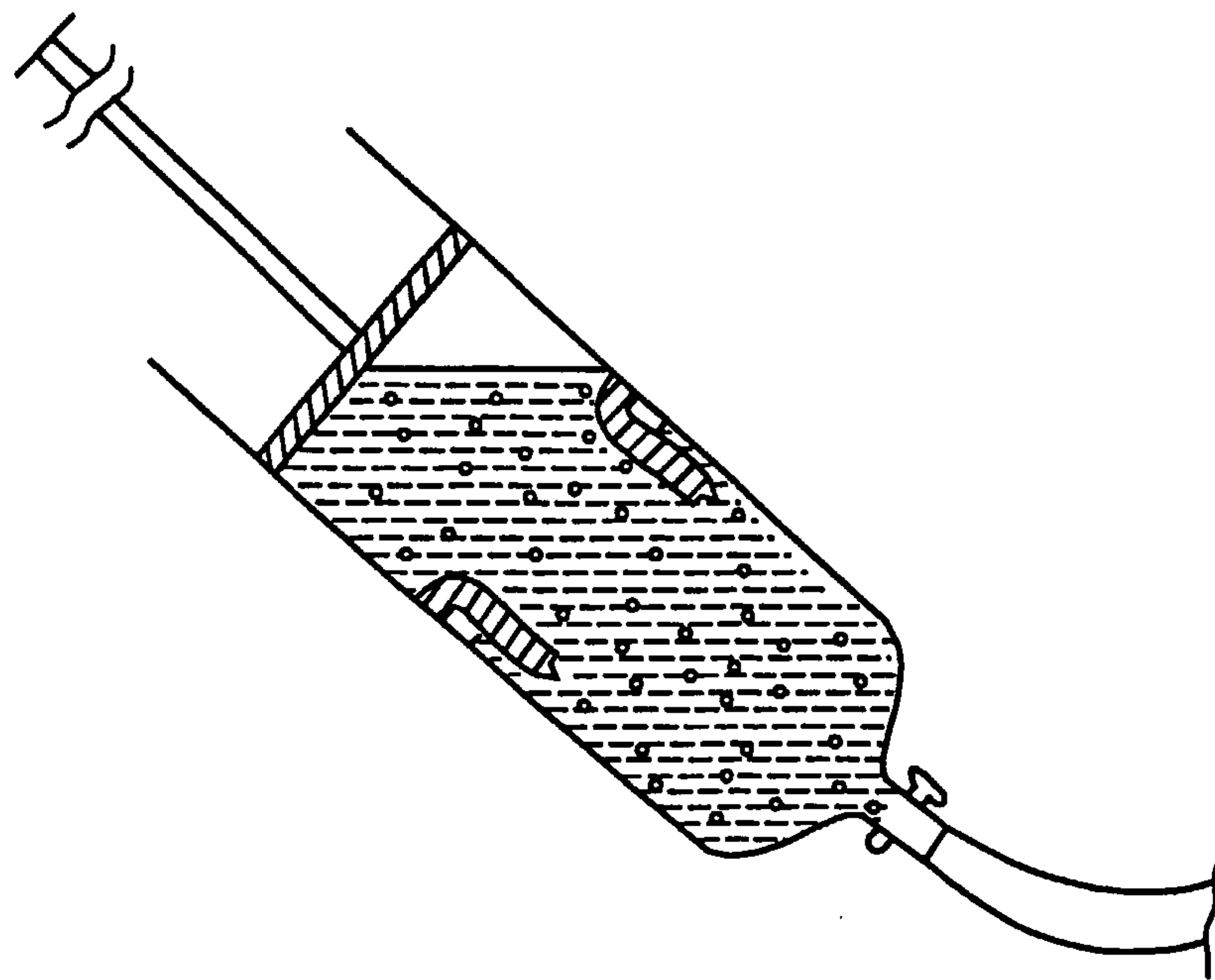

FIG. 3E

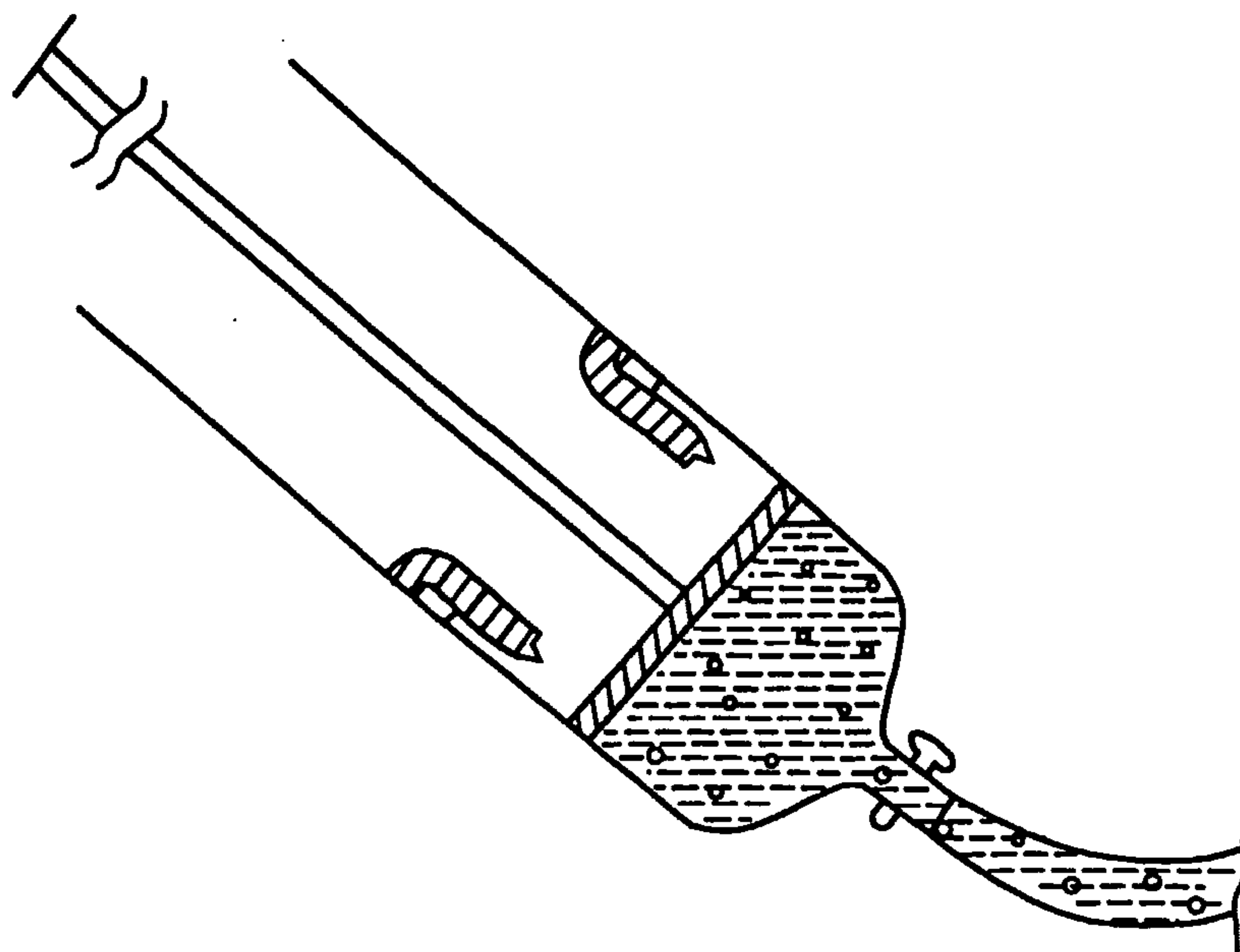

FIG. 4A

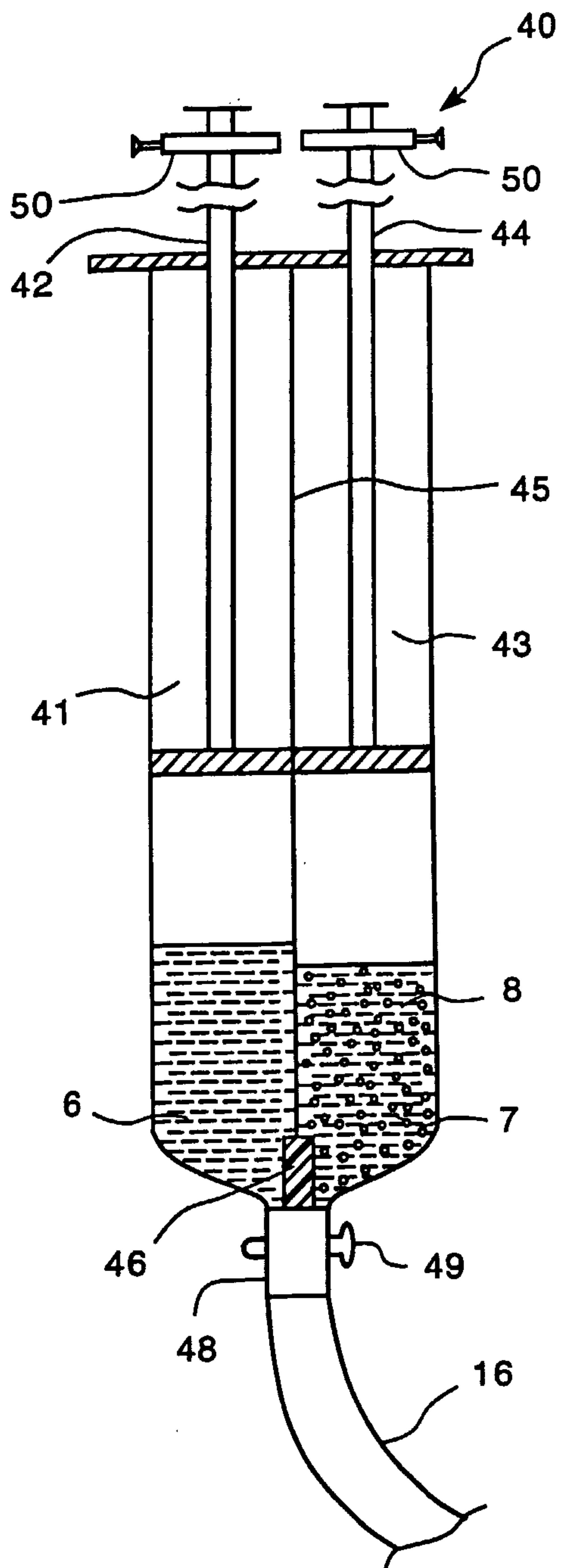

FIG. 4B

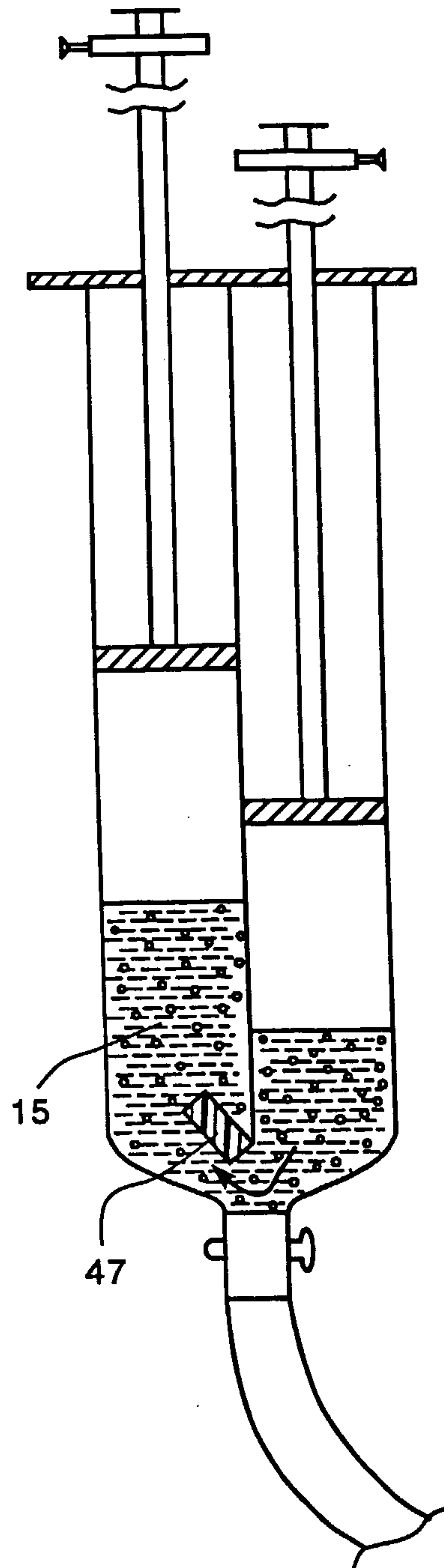

FIG. 4C

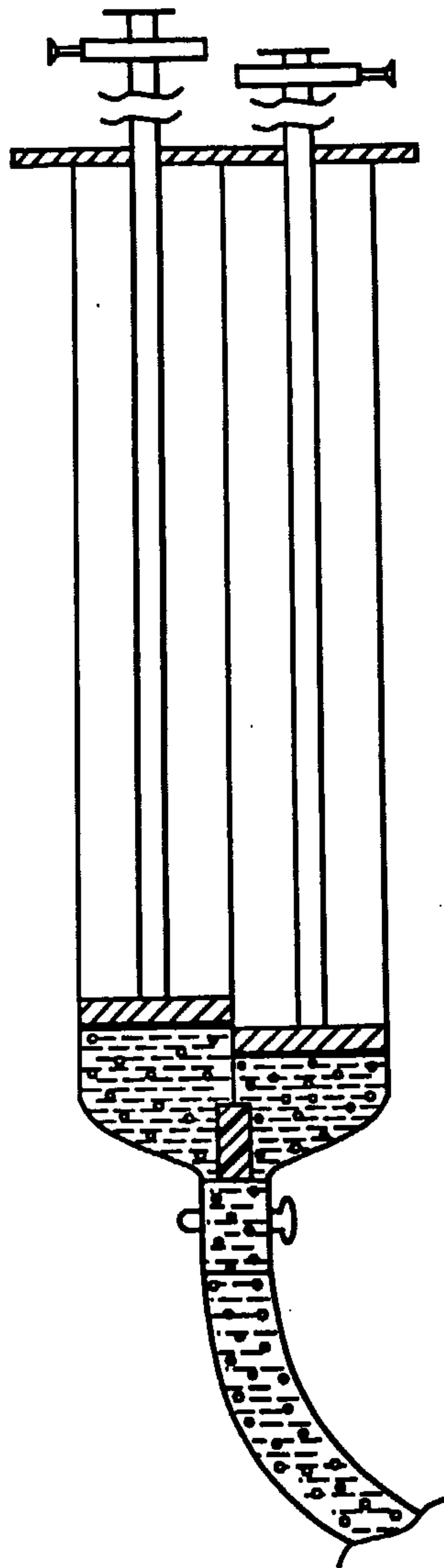

FIG. 4D

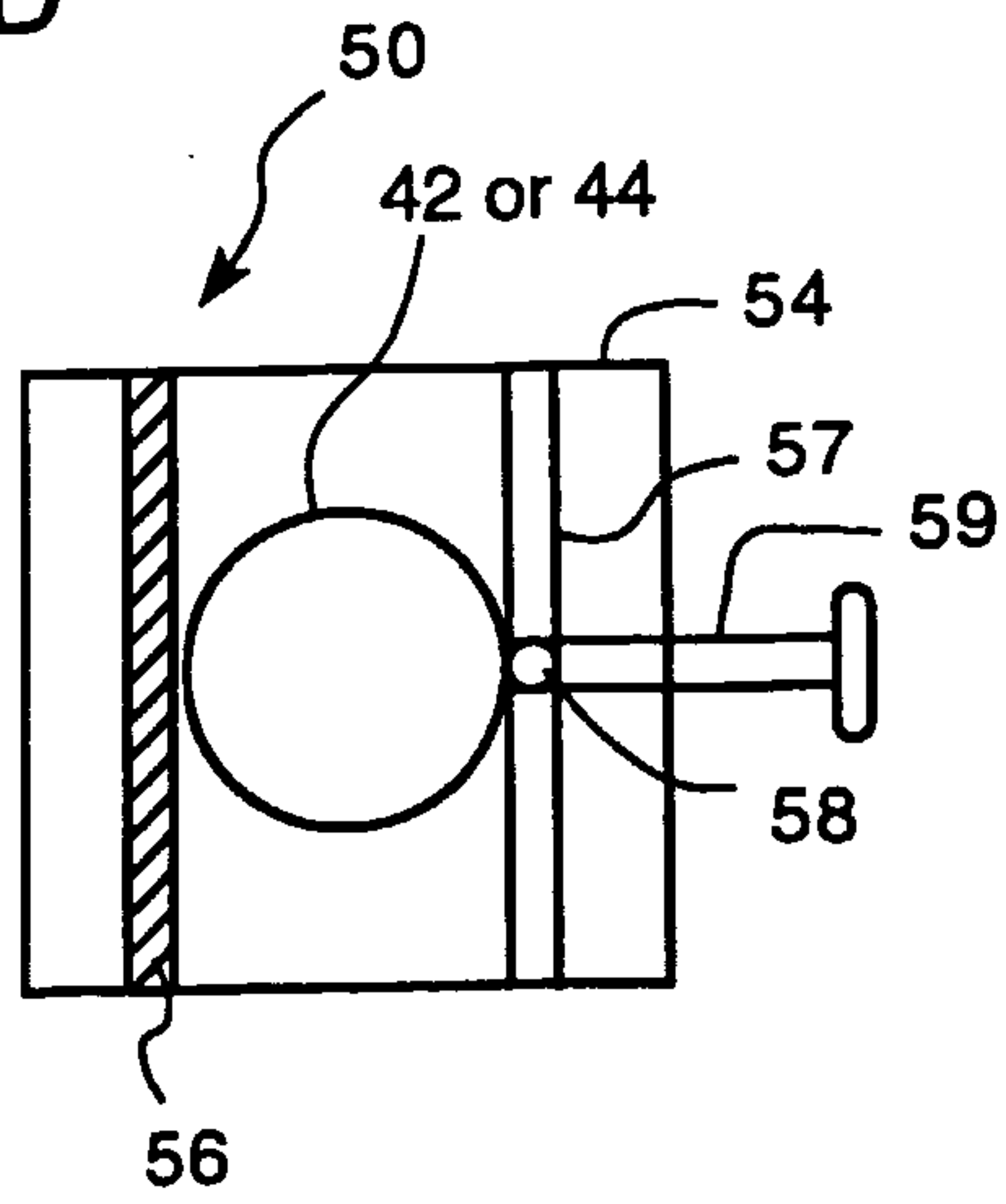

FIG. 5A

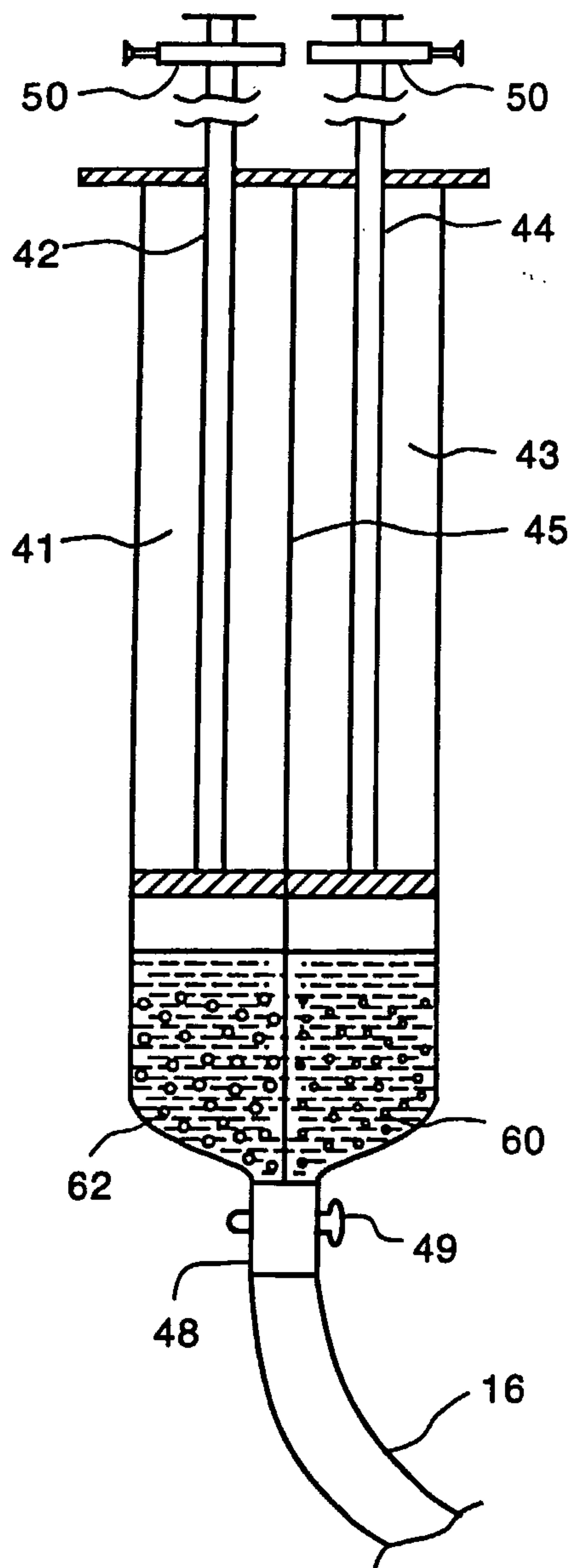

FIG. 5B

