



- (51) **International Patent Classification:**
C25B 1/00 (2006.01) *H01M 8/22* (2006.01)
C25B 5/00 (2006.01)
- (21) **International Application Number:**
PCT/US2015/055492
- (22) **International Filing Date:**
14 October 2015 (14.10.2015)
- (25) **Filing Language:** English
- (26) **Publication Language:** English
- (30) **Priority Data:**
14/688,578 16 April 2015 (16.04.2015) US
- (71) **Applicant:** SAUDI ARABIAN OIL COMPANY [SA/SA]; North Park 1, 31311 Dhahran, Saudi Arabia, 31311 (SA).
- (71) **Applicant (for AG only):** ARAMCO SERVICES COMPANY [US/US]; 9009 West Loop South, Houston, Texas 77210-4535 (US).
- (72) **Inventors:** SOUENTIE, Stanatios; North Park 1, Dhahran, 31311 (SA). BALLESTEROS, Alberto L.; North Park 1, Dhahran, 31311 (SA). SIMEON, Fritz; North Park 1, Dhahran, 31311 (SA).
- (74) **Agents:** BRENTLINGER, Nicolas A. et al.; Dinsmore & Shohl LLP, One South Main Street, Fifth Third Center - Suite 1300, Dayton, Ohio 45402 (US).

- (81) **Designated States** (unless otherwise indicated, for every kind of national protection available): AE, AG, AL, AM, AO, AT, AU, AZ, BA, BB, BG, BH, BN, BR, BW, BY, BZ, CA, CH, CL, CN, CO, CR, CU, CZ, DE, DK, DM, DO, DZ, EC, EE, EG, ES, FI, GB, GD, GE, GH, GM, GT, HN, HR, HU, ID, IL, IN, IR, IS, JP, KE, KG, KN, KP, KR, KZ, LA, LC, LK, LR, LS, LU, LY, MA, MD, ME, MG, MK, MN, MW, MX, MY, MZ, NA, NG, NI, NO, NZ, OM, PA, PE, PG, PH, PL, PT, QA, RO, RS, RU, RW, SA, SC, SD, SE, SG, SK, SL, SM, ST, SV, SY, TH, TJ, TM, TN, TR, TT, TZ, UA, UG, US, UZ, VC, VN, ZA, ZM, ZW.
- (84) **Designated States** (unless otherwise indicated, for every kind of regional protection available): ARIPO (BW, GH, GM, KE, LR, LS, MW, MZ, NA, RW, SD, SL, ST, SZ, TZ, UG, ZM, ZW), Eurasian (AM, AZ, BY, KG, KZ, RU, TJ, TM), European (AL, AT, BE, BG, CH, CY, CZ, DE, DK, EE, ES, FI, FR, GB, GR, HR, HU, IE, IS, IT, LT, LU, LV, MC, MK, MT, NL, NO, PL, PT, RO, RS, SE, SI, SK, SM, TR), OAPI (BF, BJ, CF, CG, CI, CM, GA, GN, GQ, GW, KM, ML, MR, NE, SN, TD, TG).

Declarations under Rule 4.17:

- as to applicant's entitlement to apply for and be granted a patent (Rule 4.17(ii))
- as to the applicant's entitlement to claim the priority of the earlier application (Rule 4.17(iii))

Published:

- with international search report (Art. 21(3))

(54) **Title:** METHODS FOR CO-PROCESSING CARBON DIOXIDES AND HYDROGEN SULFIDE

(57) **Abstract:** A method for co-processing H₂S and CO₂ in an electrolyzer includes feeding a first gas stream having H₂S to an anode and feeding a second gas stream having CO₂ to a cathode. The H₂S is split into hydrogen ions and elemental sulfur. The hydrogen ions are transferred from the anode to the cathode, and the CO₂ is hydrogenated with the transferred hydrogen ions. A method for producing electricity in a fuel cell includes feeding a first gas stream having H₂S and CO to an anode, and feeding a second gas stream having oxygen to a cathode. The H₂S and CO forms hydrogen ions and carbonyl sulfide. The hydrogen ions are transferred from the anode to the cathode. The transferred hydrogen is oxidized with the oxygen of the second gas stream, and electricity formed from the oxidation is collected.



-1-

METHODS FOR CO-PROCESSING CARBON DIOXIDES AND HYDROGEN SULFIDE

CROSS REFERENCE TO RELATED APPLICATIONS

[0001] The present application claims priority to U.S. Patent Application No. 14/688,578, filed April 16, 2015, entitled “Methods for Co-Processing Carbon Dioxide and Hydrogen Sulfide” (Docket SA 6014 PA), the contents of which are hereby incorporated by reference in their entirety.

BACKGROUND

Field

[0002] The present specification generally relates co-processing carbon dioxide (CO₂) and hydrogen sulfide (H₂S). More particularly, the present specification is directed to electrochemical methods for producing high-value chemicals by co-processing byproduct streams of CO₂ and H₂S.

Technical Background

[0003] Hydrogen sulfide and carbon dioxide are two common compounds that are present in some naturally occurring hydrocarbon deposits. These compounds are generally removed from the hydrocarbon and are of low value as extracted. Therefore, H₂S and CO₂ are generally either discarded or further processed into various compounds of more value. Currently, CO₂ and H₂S are separately processed, which leads to higher overhead costs and other inefficiencies.

[0004] Accordingly, systems and methods that enable more efficient treatment of H₂S and CO₂ that is removed from hydrocarbon feeds are desired.

-2-

SUMMARY

[0005] According to some embodiments, a method for co-processing H₂S and CO₂ in an electrolyzer is disclosed. The electrolyzer comprises an anode, a cathode, and an electrolyte positioned between and in electrochemical contact with the anode and the cathode. The method according to embodiments comprises: feeding a first gas stream comprising H₂S to the anode of the electrolyzer; feeding a second gas stream comprising CO₂ to the cathode of the electrolyzer; splitting H₂S of the first gas stream into hydrogen and elemental sulfur; transferring the hydrogen split from the H₂S of the first gas stream from the anode across the electrolyte to the cathode; and hydrogenating the CO₂ from the second gas stream with the hydrogen that was transferred from the anode.

[0006] According to other embodiments, a method for producing electricity in a fuel cell is disclosed. The fuel cell comprises an anode, a cathode, and an electrolyte positioned between and in electrochemical contact with the anode and cathode. The method according to embodiments comprises: feeding a first gas stream comprising H₂S and CO to the anode; feeding a second gas stream comprising oxygen to the cathode; splitting the H₂S from the first gas stream into hydrogen and elemental sulfur; forming carbonyl sulfide from the elemental sulfur split from the H₂S of the first gas stream and the CO of the first gas stream; transferring the hydrogen split from the H₂S of the first gas stream from the anode across the electrolyte to the cathode; oxidizing the hydrogen that is transferred from the anode across the electrolyte to the cathode with the oxygen of the second gas stream; and collecting electricity formed from the oxidizing of the hydrogen that is transferred from the anode across the electrolyte to the cathode.

[0007] According to yet other embodiments, another method for co-processing H₂S and CO₂ in an electrolyzer is disclosed. The electrolyzer comprises an anode, a cathode, and an electrolyte positioned between and in electrochemical contact with the anode and cathode. The method according to embodiments comprises: feeding a first gas stream comprising H₂S and CO₂ to the anode; splitting the H₂S from the first gas stream into hydrogen and elemental sulfur; forming SO_x and CO from the elemental sulfur split from the H₂S of the first gas stream and the CO₂ of the first gas stream; transferring the hydrogen split from the H₂S of the

-3-

first gas stream from the anode across the electrolyte to the cathode; exhausting the hydrogen transferred from the anode across the electrolyte to the cathode from the electrolyzer consuming electricity.

[0008] Additional features and advantages will be set forth in the detailed description which follows, and in part will be readily apparent to those skilled in the art from that description or recognized by practicing the embodiments described herein, including the detailed description which follows, the claims, as well as the appended drawings.

[0009] It is to be understood that both the foregoing general description and the following detailed description describe various embodiments and are intended to provide an overview or framework for understanding the nature and character of the claimed subject matter. The accompanying drawings are included to provide a further understanding of the various embodiments, and are incorporated into and constitute a part of this specification. The drawings illustrate the various embodiments described herein, and together with the description serve to explain the principles and operations of the claimed subject matter.

BRIEF DESCRIPTION OF THE DRAWINGS

[0010] FIG. 1 schematically depicts a conventional electrolysis unit for treating H₂S;

[0011] FIGS. 2A and 2B schematically depict conventional H₂S fuel cells;

[0012] FIG. 3 schematically depicts an electrolyzer for co-processing H₂S and CO₂ according to embodiments described herein;

[0013] FIG. 4A schematically depicts a second electrolyzer for co-processing H₂S and CO₂ according to embodiments described herein;

[0014] FIG. 4B schematically depicts a H₂S fuel cell according to embodiments described herein;

[0015] FIG. 5 schematically depicts a third electrolyzer for co-processing H₂S and CO₂ according to embodiments described herein;

[0016] FIG. 6 schematically depicts a fourth electrolyzer for co-processing H₂S and CO₂ according to embodiments described herein;

[0017] FIG. 7A schematically depicts a fifth electrolyzer for co-processing H₂S and CO₂ according to embodiments described herein;

[0018] FIG. 7B schematically depicts a second H₂S fuel cell according to embodiments described herein;

[0019] FIG. 8A is a graphical representation of the Gibbs free energy for a reaction between elemental sulfur and CO₂; and

[0020] FIG. 8B. is a graphical representation of enthalpy for a reaction between elemental sulfur and CO₂.

DETAILED DESCRIPTION

[0021] Methods for treating H₂S and CO₂ separately are disclosed below. These methods generally require significant amounts of energy and are inefficient compared to embodiments disclosed herein. While the below methods are described in detail and with specific reaction mechanisms, it should be understood that various other reaction mechanisms may occur and fall within the scope of this disclosure.

[0022] Methods for processing H₂S involve Claus reactions that use high temperatures to oxidize H₂S to SO₂ and then further to elemental sulfur. For example, in a Claus unit gaseous H₂S generally undergoes a substoichiometric combustion at temperatures of about 1,000 °C to form gaseous SO₂ that then reacts with uncombusted gaseous H₂S to form elemental sulfur, as shown in reactions (1) and (2) set forth below:

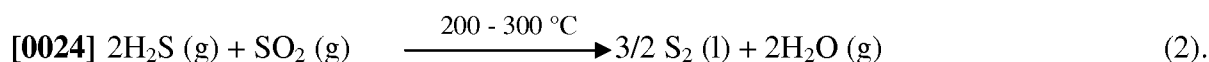
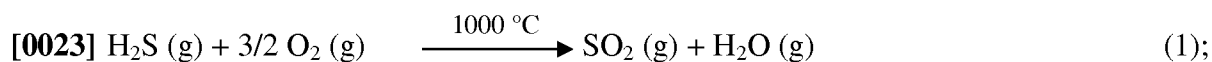

[0025] Diatomic S₂, as formed in the above reactions, is highly reactive and reacts primarily with other diatomic S₂ to form an S₈ allotrope as shown in reaction (3) below:



[0027] As shown in reactions (2) and (3) above, the recovery of elemental sulfur from H₂S comprises three sub-steps: heating a mixture of H₂S and SO₂ to a temperature from about 200 °C to about 300 °C; a catalytic reaction; and cooling plus condensation. These three sub-steps are generally repeated up to three times to convert a maximum amount of H₂S to elemental sulfur and water. These reactions are exothermic and a portion of the reaction energy may be recovered as low-grade energy, such as by producing steam or the like. However, the energy capture is not very efficient.

[0028] In conventional treatments, when CO₂ is present in the gas feed, the same reaction processes shown in reactions (1) – (3) above may be used. In such a case, the CO₂ is inert and does not react or combust with the other constituents. Thus, in conventional treatments CO₂ exits the reaction unit without reacting, and is discarded or further treated. This leads to inefficiencies by requiring additional units and further processing.

[0029] In reactions (1) – (3) shown above, the Claus process converts hydrogen atoms of H₂S into steam via an oxidation reaction. As shown above, the Claus reactions do not produce very useful products, and the above reactions cannot be used to treat CO₂ that may be present in the feed stream, or that is exhausted from a CO₂ capture unit.

[0030] Another conventional method for treating H₂S is the Stenger-Wasas Process (SWAP) developed by SWAPSOL Corp. In SWAP, H₂S and CO₂ are reacted to form water, sulfur, heat, and carsul (a black insoluble material formed by the reaction between carbon and sulfur). The carsul formed by SWAP can then be heated to produce carbon-based monomers and sulfur. SWAP may be used as an alternative of the Claus process described by Reactions (1) – (3) above, and can be applied to flue gasses, sour gasses, landfill gasses, Claus tail gasses, hydrocarbon waste recycling, and the like. A reaction mechanism for SWAP is shown in reaction (4) below:

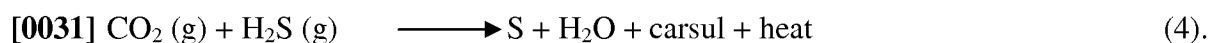

-6-

[0032] Although SWAP does treat a feed comprising both CO₂ and H₂S, it produces intermediary components that are not very useful and should be further processed into usable chemicals.

[0033] As an alternative of, or in addition to, the above chemical reactions for processing H₂S, electrochemical processes may be used. Electrochemical processes according to embodiments may be carried out using an electrolysis unit, such as the electrolysis unit depicted in FIG. 1. In the electrolysis unit of FIG. 1 a proton conducting electrolyte membrane is used to split H₂S into elemental sulfur (S_n, where n is from 2 to 8) at an anode and diatomic hydrogen (H₂) at the cathode.

[0034] With reference now to FIG. 1, an electrolysis unit 100 comprises a feed gas channel 140 where a feed gas 110 comprising H₂S is fed into the electrolysis unit 100. The feed gas 110 is fed into the electrolysis unit 100 at the anode 160 side of the electrolysis unit 100. The anode 160 is positively charged and splits the H₂S in the feed gas into elemental sulfur and hydrogen atoms. The hydrogen atoms migrate across an electrolyte 170, as shown by arrows 190, toward the negatively charged cathode 180, and gaseous diatomic hydrogen is formed. The gaseous hydrogen enters an exhaust channel 150 of the electrolysis unit 100 and is then exhausted from the exhaust channel as shown by arrow 130. Elemental sulfur exits the electrolysis unit 100 at the end of the feed channel 140, as shown by arrow 120. A reaction mechanism that occurs at the anode 160 is shown in reaction (5) below, and a reaction mechanism that occurs at the cathode 180 is shown in reaction (6) below:



[0037] To achieve the above electrolysis of H₂S, specific anodes 160 and electrolytes 170 that facilitate the treatment of feed gases comprising H₂S are used. For example, platinum is a common anode catalyst material because it generally has good catalytic activity (i.e., it has good H₂S adsorption). However, platinum degrades over time when exposed to feed gases comprising H₂S and, thus, is not a preferable anode material for electrolyzer designed to treat H₂S. Likewise, many other metal oxides commonly used as anode materials degrade rapidly

-7-

when exposed to H₂S. Thus, in embodiments, other anode materials are used. For instance, in embodiments the anode may comprise a metal sulfide, such as, for example, Li₂S/CoS_{1.35}WS₂, NiS, MoS₂, CoS, VO₅, LiCoO₂, Pt/TiO₂, Pd, Au, Ag, Ru, Rh, Ir, FeMoS, NiMoS, CoMoS and mixtures thereof. In embodiments, Ni-based compounds may be used as anode materials, such as Nb₂O₅-Ni, BaO-Ni, Ce_{0.8}Sm_{0.2}O₂-Ni. In embodiments, thiospinels may be used as anode materials, such as CuFe₂S₄, CuNi₂S₄, CuCoS₄, NiCo₂S₄, NiFe₂S₄, and mixed metal oxides of La, Sr, Mn, Ti, Cr, Ga, Y, V, Fe, Co, Mo, Ce, Mg, Gd, and Ba (e.g. La_{0.4}Sr_{0.6}BO₃, where B=Mn, Ti, Cr). Most of the above-mentioned materials have been reported to exhibit electrochemical activity for H₂S utilization in both fuel cells and electrolyzers. According to embodiments, the above materials can be used either as is or in mixture with another oxide in the form of ceramic-metallic (cermet) electrode. In embodiments comprising cermet electrodes, oxides that conduct oxygen or protons can be used, such as YSZ, ScSZ, ScYSZ, GDC, CGO, CeO₂, TiO₂, Nb₂O₅, SDC, BCY, CZI, BCN, or the like.

[0038] Although many electrolytes that transmit H⁺ may be used as the electrolyte 170 in the electrolysis unit 100, in embodiments the electrolyte 170 is chosen according to its proclivity to treat H₂S, such as a resistance to sulfur degradation. In general, perovskite materials of the general type ABO₃ and ABMO₃ exhibit proton conductivity at high temperatures (600-1000°C). In some embodiments, zirconia-based electrolytes are used in the electrolysis unit, such as SrZrO₃ and NiO-doped BZY. In other embodiments, ceria-based electrolytes are used in the electrolysis unit, such as BaCeO₃, SrCeO₃ or YDC, SDC, BCY, BCN and CZI. In yet other embodiments, the electrolyte may be a solid acid of the general type MHXO₄ and M₃H(XO₄)₂, where M can be Cs, NH₄, Rb, and X can be S or Se. These materials exhibit protonic conductivity at low temperatures, in the range 25 to 300°C and are known to undergo a "superprotonic" phase transition.

[0039] In addition to the above treatment options for H₂S, it can be used in solid oxide fuel cells to produce electric energy. Two types of fuel cells may be used with H₂S; fuel cells comprising oxygen-conducting solid electrolytes and fuel cells comprising proton-conducting solid electrolytes.

-8-

[0040] FIG. 2A shows a solid oxide fuel cell 200 with a proton conducting solid electrolyte 250. The fuel cell 200 includes a first feed channel 230 and a second feed channel 280. Between the first feed channel 230 and the second feed channel 280 are an anode 240, a cathode 260, and the electrolyte 250 between, and in electrochemical contact with, the anode 240 and the cathode 260. The anode, 240, electrolyte 250, and cathode 260 are constructed so that protons can be transferred from the anode 240 through the electrolyte 250 and to the cathode 260. The fuel cell 200 also comprises an electrical connection 290 between the anode 240 and the cathode 260.

[0041] In operation, the solid oxide fuel cell depicted in FIG. 2A is fed a gas stream 210 comprising H₂S at the first feed channel 230 and air 212 is fed to the second feed channel 280. At the anode 240 the H₂S is anodically oxidized to H⁺ and elemental sulfur S_n as shown in Reaction (7) below:



[0043] The protons (H⁺) formed in Reaction (7) are transferred from the anode 240 through the electrolyte 250 to the cathode 260, as shown by arrows 292. The electrons formed by Reaction (7) are transferred by the electrical connection 290 between the anode 240 and the cathode 260, as shown by arrow 270. The Elemental sulfur S_n 220 formed by Reaction (7) exits the fuel cell via the first feed channel 230.

[0044] At the cathode 260 the H⁺ ions are oxidized by the oxygen in the fed air 212 and water is produced, as shown in Reaction (8) below:



[0046] A mixture 222 of the gaseous H₂O produced by Reaction (8) and the unreacted air exit the fuel cell 200 at the second feed channel 280.

[0047] FIG. 2B shows a solid oxide fuel cell 200 with an oxygen-ion conducting solid electrolyte 250. The fuel cell 200 includes a first feed channel 230 and a second feed channel 280. Between the first feed channel 230 and the second feed channel 280 are an anode 240, a cathode 260, and the electrolyte 250 between, and in electrochemical communication with,

-9-

the anode 240 and the cathode 260. The anode, 240, electrolyte 250, and cathode 260 are constructed so that oxygen ions can be transferred from the cathode 260 through the electrolyte 250 and to the anode 240. The fuel cell 200 also comprises an electrical connection 290 between the anode 240 and the cathode 260.

[0048] In operation, the solid oxide fuel cell depicted in FIG. 2B is fed a gas stream 210 comprising H₂S at the first feed channel 230 and air 212 is fed to the second feed channel 280. At the cathode 260 oxygen from the air is ionized, as shown in Reaction (9) below:



[0050] The oxygen ions formed in Reaction (9) transfer from the cathode 260 through the electrolyte 250 to the anode 240, as shown by arrows 294. Unreacted air 222 exits the fuel cell 200 at the second feed channel 280.

[0051] At the anode 240 the O²⁻ ions, which were transferred from the cathode 260 and through the electrolyte 240, react with the H₂S to form elemental sulfur (S_n), SO_x, and H₂O, as shown in Reactions (10) and (11) below:

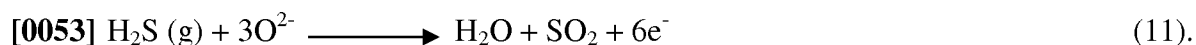
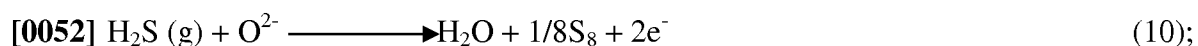

[0054] A mixture 222 of the gaseous H₂O, SO_x, and elemental sulfur produced by Reactions (10) and (11) exit the fuel cell 200 at the first feed channel 230. The electrons formed by Reactions (10) and (11) are transferred from the anode 240 to the cathode 260 via the electrical connection 290, as shown by arrow 270.

[0055] Although fuel cells using a proton transferring solid oxide electrolyte and an oxygen ion transferring solid oxide electrolyte can both be used, the power efficiency per mole of H₂S is higher in the oxygen ion transferring electrolyte because both the hydrogen and the sulfur atoms act as fuel and are electrochemically oxidized to produce electricity. Solid metal sulfide-based catalyst electrodes, such as MoS₂ or WS₂, may be used as electrodes, particularly the anode, in the fuel cells disclosed above.

[0056] The above processes are conventional treatments for H₂S that split the H₂S in a feed stream to form elemental sulfur and hydrogen. As disclosed above, splitting of H₂S results in products that can either be reused, or in the formation of electricity in the case of a fuel cell. However, as disclosed above, these processes can be inefficient by requiring large amounts of energy.

[0057] Like H₂S, CO₂ is present in many hydrocarbon deposits and is receiving attention as a pollutant. It is expected that CO₂ will be more heavily regulated in the near future. Accordingly, processes that convert CO₂ into usable chemicals are desired. One such process is CO₂ hydrogenation, where CO₂ is hydrogenated to usable chemicals such as, for example, hydrocarbons, monomers or polymers, and oxygenates. Hydrogenation of CO₂ to hydrocarbons or alcohols is attractive because it is a potential source of renewable fuels while decreasing CO₂ emissions.

[0058] Many CO₂ hydrogenation processes use metal catalysts, such as, for example, Pt, Rh, Pd, Ru, Cu, Fe, Co, and Ni. The hydrogenation process takes place in fixed bed reactors where the metal catalysts are supported by metal oxide supports, such as, for example, Nb₂O₃, ZrO₂, Al₂O₃, and SiO₂. The catalytic hydrogenation generally operates at high pressure (such as, for example, from about 5 to about 70 atm, or from about 10 to about 60 atm, or even from about 20 to about 50 atm) to increase the thermodynamic equilibrium conversion to light hydrocarbons or alcohols, such as methanol. The two main reactions that take place during the catalytic hydrogenation are shown in reactions (12) and (13) below:

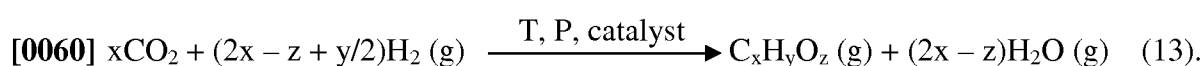
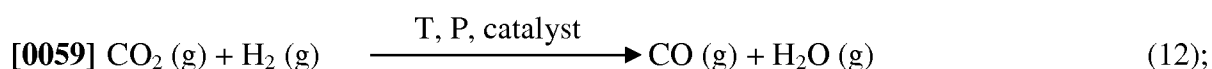

[0061] In the above, Reaction (12) takes place at temperatures from about 300 °C to about 1000 °C and is favored at higher temperatures, and Reaction (13) takes place at lower temperatures, such as from about 200 °C to about 800 °C, depending on the desired product (C_xH_yO_z). Reviewing the reaction temperature ranges of Reactions (12) and (13) interestingly shows the importance of using intermediate-temperature electrolysis and fuel cell devices, such as devices that operate from about 500 °C to about 700 °C.

[0062] Reaction (12) above is a redox reaction that constitutes a reverse water-to-gas shift reaction. Reaction (13) above is a synthesis reaction that leads to the formation of hydrocarbons (such as, for example, methane, ethane, propane, etc.), alcohols (such as methanol, ethanol, propanol, etc.), or both. For example, in Reaction (13), methane is formed when $x = 1$, $y = 4$, and $z = 0$, but methanol is formed when $x = 1$, $y = 4$, and $z = 1$. An advantage of using gaseous catalytic hydrogenation reactions, such as those shown in Reactions (12) and (13), over liquid-based hydrogenation reactions is that they have relatively high reaction rates that are comparable with other industrial processes (i.e., the hydrogenation reactions consistently produce product). Thus, such gaseous hydrogenation reactions can reliably be used to hydrogenate CO_2 into more useful chemicals, such as hydrocarbons, polymers, and alcohols.

[0063] In addition to the chemical hydrogenation of CO_2 shown above, electrochemical processes can be used in a reduction-conversion reaction with CO_2 . Such processes can generally convert liquid phase-dissolved CO_2 into more usable chemical products. In these electrochemical processes CO_2 is dissolved into solvent, such as water or another primarily aqueous solvent, and is electrochemically reduced at a cathode. Suitable cathode materials include Cu, Ag, Pd, or Rh. However, electrochemical hydrogenation of gaseous CO_2 may also be used, but has previously been limited to co-electrolysis of CO_2 and H_2O to syngas (CO and H_2). Reactions (14) and (15) below show gaseous hydrogenation:

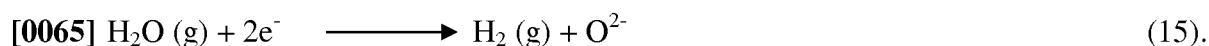
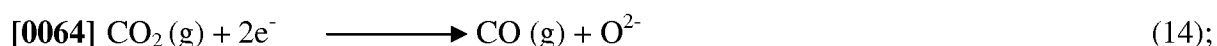

[0066] In addition to the above electrochemical reduction-conversion reaction, electrochemical processes can be used to promote the catalytic hydrogenation of CO_2 , which is shown in Reactions (12) and (13). In these processes, a constant current or potential is provided between a working electrode, which may also be acting as a catalyst, and a counter or reference electrode. Such a current or potential causes a migration of promoting species (ionic species accompanied by their mirror charge in the catalyst) from an electrolyte support to a catalyst/gas phase interface. These promoting species promote the catalytic gas phase reaction. For example, in Reactions (12) and (13), the electrochemically produced proton

species can promote the catalytic reaction in a reversible and controllable way by promoting the catalytic activity of the catalyst electrode for the hydrogenation reaction.

[0067] As discussed above, there are several differing methodologies for converting H₂S and CO₂ into more useful products. However, these methodologies are time and energy intensive and are generally carried out in separate equipment and/or at separate operating conditions. However, it has been found that a common condition may be used to unite the two methodologies in a more efficient and less energy intensive way. As discussed above, CO₂ conversion generally requires H₂ to hydrogenate the CO₂ thereby forming more useful products. The hydrogen source for hydrogenating CO₂ is generally obtained from splitting H₂O. As discussed in embodiments below, combining the H₂S treatment—where H₂ and elemental sulfur are produced with only 17% of the energy needed to split H₂O—and the CO₂ hydrogenation, where H₂ is required, creates efficiencies for both processes while reducing the total amount of energy and reaction units required to treat H₂S and CO₂.

[0068] The embodiments disclosed below can be used in any industry where treatment of H₂S and CO₂ is desired. For example, in processes where CO₂ and H₂S are produced separately, the two streams can be combined and treated in the various embodiments disclosed below, or the two streams may be fed to different portion of an electrolyzer, as disclosed in other embodiments below. However, embodiments are particularly useful in the oil and gas processing industries where high levels of CO₂ and H₂S are produced, and where sour gas, which naturally comprises both CO₂ and H₂S, is refined. For instance, an oil refinery may produce about 700 Mt/yr CO₂ and 70 Mt/yr H₂S, which are currently converted at about 4%. Embodiments disclosed herein can increase that conversion percentage and undertake the conversions using less energy and reaction units.

[0069] Various embodiments disclosed herein comprise electrochemically splitting H₂S in high temperature proton conducting solid oxide electrolyzers for *in situ*, parallel conversion of CO₂ over a catalytic cathode. Further details of embodiments will be disclosed with reference to the figures below.

[0070] With reference to FIG. 3, embodiments include an electrolyzer 300 comprising a housing 301. The housing comprises inlets 350 and 360 and outlets 355 and 365. In

-13-

embodiments, the electrolyzer 300 comprises an anode 320, a proton-conducting electrolyte 340, and a cathode 330 encased within the housing 301. Electric current may be applied to the electrolyzer 300 by a current source 310 via an electrical connection 315.

[0071] In the embodiment shown in FIG. 3, a gaseous feed stream comprising H₂S and gaseous feed stream comprising CO₂ are fed to the electrolyzer 300 in separate feed streams. The feed stream comprising gaseous H₂S is fed to the anode 320 of the electrolyzer 300 through the inlet 350 in the housing 301. The gaseous H₂S is split at the anode 320 into elemental sulfur (also referred to herein as S_n, where n = 1, 2, 6, or 8) and H⁺, as shown in Reaction (5) above. The elemental sulfur exits the electrolyzer 300 as an exhaust gas stream at outlet 355 in the housing 301. Simultaneously, the feed stream comprising gaseous CO₂ is fed to the cathode 330 of the electrolyzer 300 through the inlet 360 in the housing 301. The H⁺ ions, which are generated at the anode 320, are transferred through the proton-conducting electrolyte 340, as indicated by arrow 370, to the cathode's 330 three phase boundary (tpb) comprising the cathode 330, the proton-conducting electrolyte 340, and the gaseous phase (CO₂ and corresponding reactants). The H⁺ ions react at the three phase boundary with CO₂ adsorbates present at the proximity of the three phase boundary to form various chemicals (such as methane and methanol), as shown in Reaction (16) below:

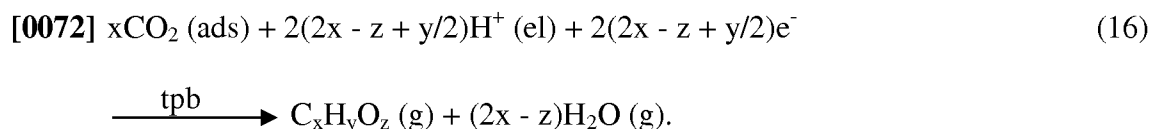

[0073] The C_xH_yO_z component then exits the electrolyzer 300 from the outlet 365 as an exhaust gas stream at outlet 365 in the housing 301, where it can be collected for further use. The above Reaction (16) can take place at temperatures from about 200 °C to about 800 °C depending on the desired product. However, in embodiments, temperatures below 700 °C are preferable. The process pressure of Reaction (16) can vary from about 1 atm to about 70 atm, which is similar to the process pressure in methanol synthesis and Fischer-Tropsch reactors. In embodiments, equal pressure is applied to the anode side, and the feed flow is adjusted according to the activity of the catalyst given the desired conversion and reactor size. However, in embodiments, space velocities in the range from about 500 h⁻¹ to about 30,000 h⁻¹ can be used.

[0074] In some embodiments, in addition to, or as an alternative of, Reaction (16), the H^+ ions react with one another to form gaseous H_2 that may participate in the catalytic hydrogenation of CO_2 , which is shown in Reactions (12) and (13).

[0075] The ratio of catalytic hydrogenation by gaseous H_2 (as shown in Reactions (12) and (13)) and electrocatalytic hydrogenation by H^+ (as shown in Reaction (16)) is a function of process parameters, such as pressure, temperature, feed flow, etc. For example, H_2 evolution at the cathode is suppressed at high pressures and low temperatures and thus atomic hydrogen coverage of the cathode catalyst electrode is higher, which can result in higher CO_2 hydrogenation rates. However, the ratio of catalytic/electrocatalytic hydrogenation may also be affected by the catalyst electrode properties, such as CO_2 surface dissociation / activation ability. Accordingly, in embodiments, selecting the appropriate cathode material can be important. In some embodiments, typical cathode materials, such as Rh, Ru, Cu, Fe, Co, Pd, Pt, Ni can be used either as metal porous electrodes or as cermet electrodes when mixed with a ceramic electrolyte support (oxygen or proton conductor), like YSZ, ScSZ, ScYSZ, GDC, CGO, CeO_2 , TiO_2 , Nb_2O_5 , SDC, BCY, BZY, CZI, BCN, etc, due to their well known activity in CO_2 hydrogenation.

[0076] Water present at the cathode 330, such as the H_2O formed by Reactions (12), (13), and (16), will facilitate proton transfer 370 across the electrolyte 340. In some embodiments the generation of water will not be sufficient to facilitate proton transfer 370 across the electrolyte 340. In such cases, humidified CO_2 may be fed to the electrolyzer 300. Using water from humidified CO_2 to facilitate transfer of protons 370 across the electrolyte 340 may increase the efficiency of the process because an in-line dehumidifier will not be required. In embodiments, the feed stream comprising CO_2 may comprise from about 2% to about 15% gaseous H_2O , such as from about 3% to about 10% gaseous H_2O , or even from about 5% to about 8% gaseous H_2O . The exact amount of H_2O in the humidified CO_2 feed depends on the electrolyte material 340 and the current applied to the anode 320 and the cathode 330. Like the anode 320, in embodiments, the electrolyte also must be able to tolerate sulfur exposure without significant degradation. Accordingly, in embodiments, the electrolyte 340 may include perovskite materials of the general type ABO_3 and $ABMO_3$ that exhibit proton conductivity at high temperatures (600-1000°C), zirconia- and ceria-based proton conducting

-15-

electrolytes, like SrZrO₃, NiO-doped BZY, BaCeO₃, SrCeO₃ or others like YDC, SDC, BCY, BCN and CZI. In yet other embodiments, the electrolyte may be a solid acid of the general type MHXO₄ and M₃H(XO₄)₂, where M can be Cs, NH₄, Rb, and X can be S or Se. These materials exhibit protonic conductivity at low temperatures, in the range 25 to 300°C and are known to undergo a "superprotonic" phase transition.

[0077] In some embodiments, the electrolyte 340 may not require H₂O to facilitate the transfer of protons 370 across the electrolyte 340. Like the anode 320, in embodiments, the electrolyte also must be able to tolerate sulfur exposure without significant degradation. For example, Ni-doped BZY does not require H₂O at all, and the above categories of proton conducting electrolytes exhibit an adequate sulfur tolerance.

[0078] Anode 320 materials are directly exposed to H₂S and, thus, the anode 320 materials are selected that are highly resistant to sulfur degradation. In embodiments, the anode 320 may comprise Li₂S/CoS_{1.35} or WS₂ NiS, MoS₂, CoS, VO₅, LiCoO₂, Pt/TiO₂, Pd, Au, Ag, Ru, Rd, Ir, FeMoS, NiMoS, CoMoS and mixtures of them. Also, Ni-based materials like Nb₂O₅-Ni, BaO-Ni, Ce_{0.8}Sm_{0.2}O₂-Ni. Thiospinels like: CuFe₂S₄, CuNi₂S₄, CuCoS₄, NiCo₂S₄, NiFe₂S₄, and mixed metal oxides of La, Sr, Mn, Ti, Cr, Ga, Y, V, Fe, Co, Mo, Ce, Mg, Gd, Ba, e.g. La_{0.4}Sr_{0.6}BO₃ where B=Mn, Ti, Cr. Most of the above mentioned materials have been reported to exhibit electrochemical activity for H₂S utilization in both fuel cells and electrolyzers. These materials can be used either as is or in mixture with another oxide in the form of ceramic-metallic (cermet) electrode. Oxides that conduct oxygen or protons can be used such as YSZ, ScSZ, ScYSZ, GDC, CGO, CeO₂, TiO₂, Nb₂O₅, SDC, BCY, CZI, BCN, etc.

[0079] In some embodiments, the electrolyzer 300 is used downstream of a CO₂ capture unit where high purity CO₂ is available to feed to the cathode 330 of the electrolyzer 300. Although the embodiment shown in FIG. 3 is discussed above as a solid oxide electrolyte electrolysis unit, it should be understood that in other embodiments, other proton conducting membrane electrolyzers may be used (such as CsHSO₄) as long as the anode and electrolyte have sufficient sulfur tolerance, and the cathode is capable of CO₂ activation.

-16-

[0080] FIG. 4A and FIG. 4B schematically depict embodiments where H₂S and CO₂ are co-fed to an electrolyzer and a fuel cell respectively. In the embodiments disclosed in FIG. 4A and FIG. 4B, CO assists in removing the hydrogen from H₂S. In FIG. 4A, the electrolyzer 400 comprises an anode 411, a cathode 413, and an electrolyte between, and in electrochemical communication with, the anode 411 and the cathode 413. Electrical current is provided by an electrical source 420 and fed to the electrolyzer, such as fed to the anode, via an electrical connection 421.

[0081] A feed stream comprising H₂S 440 is mixed with a stream comprising CO 447 and the mixture is fed to the anode 411 of the electrolyzer 400. In some embodiments, the anode 411 may comprise a metal sulfide catalyst. In embodiments, the metal sulfide catalyst -anode may be of a group of metal sulfides exhibiting high activity for the Reaction (17) and also low overpotential for hydrogen oxidation (reverse Reaction (6)), like Co₉S₈, NiS, FeS, MnS, Cr₂S₃, ZnS, MoS₂, Cu₂S, V₃S₄, Ti₅S₄, WS₂, or thiospinels like: CuFe₂S₄, CuNi₂S₄, CuCoS₄, NiCo₂S₄, NiFe₂S₄ or mixtures thereof. These materials can be used either as is or in mixture with another oxide in the form of ceramic-metallic (cermet) electrode. Oxides that conduct oxygen or protons can be used such as YSZ, ScSZ, ScYSZ, GDC, CGO, CeO₂, TiO₂, Nb₂O₅, SDC, BCY, CZI, BCN, etc. At the anode, H₂S in the mixture reacts with CO in the mixture to form carbonyl sulfide (COS) and hydrogen, as shown in Reaction (17) below:



[0083] In the embodiment shown in FIG. 4A, the COS exits the anode 411 of the electrolyzer as exhaust gas stream 445. The COS is then fed to a decomposer 410 where the sulfur is separated from the CO in the COS at high temperatures in the range from about 600 °C to about 1000 °C and pressure from about 1 atm to about 50 atm. The decomposition reaction can be easily integrated thermally with the electrochemical device (electrolyzer or fuel cell) since they operate at a similar temperature range. Sulfur is released as elemental sulfur (S_n) 450 from the decomposer 410 and CO exits the decomposer as feed stream 447 and is recycled by being combined with the H₂S feed 440. The decomposition of COS into CO and S_n proceeds by Reaction (18) below:



-17-

[0085] By supplying an electrical current to the electrolyzer 400, H₂ will be oxidized at the anode 411 and transferred as protons (H⁺) across the electrolyte 412 to the cathode 413 where molecular or gaseous hydrogen will be produced. In some embodiments, there is no additional feed to the electrolyzer (i.e., feed 430 is not present) and the molecular or gaseous hydrogen will be released from the electrolyzer 400 as outlet feed 435.

[0086] In other embodiments, CO₂ may be fed to the cathode 413 as feed stream 430. In these embodiments, the H⁺ that is formed at the anode 411 and transferred across the electrolyte 412 will react at the triple phase boundary of the gaseous phase, the cathode 413, and the electrolyte, as shown in Reaction (16) above. Through Reaction (16), C_xH_yO_z is produced at the cathode and exits the electrolyzer as exhaust stream 435.

[0087] In the embodiment shown in FIG. 4B, electricity is produced by feeding oxygen or air as feed stream 430 to the electrode 416. In such embodiments, the hydrogen that is formed at the electrode 415 and transferred across the electrolyte 412 undergoes electrochemical reduction at the electrode 416. Although electrode 415 and electrode 416 may have the same compositional makeup as anode 411 and cathode 413 of the embodiments shown in FIG. 4A, because hydrogen is reduced at electrode 416, in the embodiment shown electrode 416 is referred to as a cathode and electrode 415 is referred to as an anode when referring to the embodiment shown in FIG. 4B.

[0088] In FIG. 4A of these embodiments, a feed stream comprising H₂S 440 is mixed with a feed stream comprising CO 447 and the mixture is fed to the anode 415 of the electrolyzer 400. In some embodiments, the anode 411 may comprise a metal sulfide catalyst. In embodiments, the metal sulfide catalyst may be of a group of metal sulfides exhibiting high activity for the Reaction (17) and also low overpotential for hydrogen oxidation (reverse Reaction (6)), like Co₉S₈, NiS, FeS, MnS, Cr₂S₃, ZnS, MoS₂, Cu₂S, V₃S₄, Ti₅S₄, WS₂ or thiospinels like: CuFe₂S₄, CuNi₂S₄, CuCoS₄, NiCo₂S₄, NiFe₂S₄ or mixtures thereof. In some embodiments, the cathode 413 comprises a catalyst, such as Pt, Pd, Ru, Rh, Ni, Cu, Fe, Co or other metals well known for hydrogen evolution in electrolyzers literature either as metal porous electrodes or as cermet electrodes when mixed with a ceramic electrolyte support (oxygen or proton conductor), like YSZ, ScSZ, ScYSZ, GDC, CGO, CeO₂, TiO₂, Nb₂O₅, SDC, BCY, BZY, CZI, BCN, etc, or even a perovskite electrode. At the anode 411, H₂S in

-18-

the feed stream reacts with CO in the feed stream to form carbonyl sulfide (COS) and hydrogen, as shown in Reaction (17) above. In embodiments, the COS exits the anode 411 of the electrolyzer as outlet stream 445. The COS is then fed to a decomposer 410 where the elemental sulfur is separated from the CO in the COS at elevated temperatures. The elemental sulfur is released as elemental sulfur (S_n) 450 from the decomposer 410 and CO exits the decomposer as outlet stream 447 and is recycled by being combined with the feed stream comprising H_2S 440. The decomposition of COS into CO and S_n proceeds by reaction (18) above.

[0089] In embodiments, the hydrogen that is formed at the anode 415 and transferred across the electrolyte 412 is oxidized by the oxygen or air that is introduced to the cathode 416 as feed stream 430, and H_2O is released as exhaust stream 435. In such embodiments, the electrolyzer 400 operates as a fuel cell and produces electricity by oxidizing the hydrogen is produced from the H_2S -CO cycle present at the anode. The electricity generated by oxidizing the hydrogen exits the fuel cell 401 via electrical connection 421 and is sent to an electrical device 420.

[0090] In either of the embodiments shown in FIG. 4A or FIG. 4B, removal of H_2 from the electrolyzer 400 or the fuel cell 401 during the H_2S -CO cycle has a synergistic effect on system performance. Particularly, removing the H_2 improves the extent of the H_2S -CO reaction toward higher conversions (i.e., higher H_2 production) and it will prevent the H_2 from reacting with the CO in outlet stream 447 to form methane and water, which if formed can poison the catalyst present at the anodes 411 or 415. The embodiments shown in FIG. 4A and FIG. 4B may also avoid having elemental sulfur deposit on the anodes 411 or 415, which is costly to remove.

[0091] In other embodiments, the electrolyzer shown in FIG. 4A can be used to generate high pressure hydrogen. When the anode 411 potential is higher than the minimum required potential, hydrogen is not only pumped from the anode 411, but it can also be generated at high pressures at the cathode 413 according to the Nernst equation, which is $E = E^\circ + (RT/nF)\ln(P_{H_2,cathode} / P_{H_2,anode})$, where E is the applied potential, E° is the standard cell potential ($E^\circ=0V$ in his case), R is the universal gas constant, T is the absolute temperature, F is the Faraday constant, n is the number of electrons transferred in the cell half-reaction,

-19-

$P_{\text{H}_2,\text{cathode}}$ is the partial pressure of hydrogen at the cathode, and $P_{\text{H}_2,\text{anode}}$ is the partial pressure of hydrogen at the anode. In embodiments where hydrogen is generated at the cathode 413, no feed 430 to the cathode is required. The concentration of hydrogen at the anode 411 may be controlled by the equilibrium of the reaction between H_2S and CO . However, the partial pressure of hydrogen at the cathode is dependent on the applied electrode potential. The higher of the applied electrode potential, the higher the pressure of hydrogen at the cathode is. High pressure hydrogen is desirable for use in further processes. Potential values up to the reduction potential of the used electrolyte ($E_{\text{red}}=2.3\text{V}$ for YSZ) at the operation temperature can be applied regardless the system pressure, while the generated hydrogen partial pressure is limited to the operation pressure of the system. For example, in embodiments, at 900°K and atmospheric pressure operation and 20% conversion of H_2S , 20 kPa hydrogen exists at the anode. The generation of 20 kPa at the cathode is spontaneous and thus no potential difference is needed. However, the generation of 100 kPa hydrogen at the cathode would theoretically require the application of 0.062V potential difference at the cell according to Nernst equation.

[0092] Embodiments may also include introducing a hydrogen source into an electrolyzer at the cathode. Referring now to the embodiment shown in FIG. 5, an electrolyzer 500 includes a housing 501 having inlet channels 560 and 570 and outlet channels 565 and 575. Positioned within the housing are an anode 520, a cathode 530, and an electrolyte 540 positioned between, and in electrochemical contact with, the anode 520 and the cathode 530. In the embodiments shown in FIG. 5, a feed stream comprising H_2S is fed to the anode 520 of the electrolyzer 500 via inlet channel 560 in the housing 501. The H_2S is split into elemental sulfur and hydrogen as shown in Reaction (5) above. The elemental sulfur exits the electrolyzer 500 at outlet channel 565 in the housing 501. An electrical current is provided by current source 510 to the anode by electrical connection 515. The electrical current is provided to the anode 520 and disassociates hydrogen into H^+ ions that are transferred across the electrolyte 540 to the cathode 530, as shown by arrow 550. Minimum potential required for H_2S electrolysis is 0.2 V. A feed stream comprising a mixture of CO_2 and H_2 is fed to the cathode 530 of the electrolyzer 500 via inlet channel 570 providing an additional hydrogen source for the hydrogenation of CO_2 . The H^+ ions formed at the anode 520 and transferred across the electrolyte 540 form promoting species on the surface of cathode 530 that promote

-20-

hydrogenation of CO₂ with the hydrogen supplied with the feed at inlet channel 570. By forming the promoting species, the CO₂ hydrogenation rate can be significantly improved. For example, it has been found that faradaic efficiency values of about 900 times higher than the value without promoting species, such as about 950 times higher than the value without promoting species, or even about 1000 times higher than the value without promoting species have been realized using the promoting species. Hydrogen can also be fed to the anode in the embodiments shown in FIG. 4A, which is described in more detail above. In this instance, the minimum applied potential in the electrolyzer is 0 V.

[0093] FIG. 7A is an embodiment showing an electrolyzer where CO₂ is used to aid in the sulfur removal. In the embodiment of FIG. 7A, an electrolyzer 700 is shown including a housing 701 having inlet channels 760 and 770 and outlet channels 765 and 775. Within the housing are an anode 720, a cathode 730, and an electrolyte 740 positioned between, and in electrical contact with, the anode 720 and the cathode 730. As discussed in further detail below, a feed stream comprising CO₂ is introduced at inlet channel 760 to aid in the removal of sulfur.

[0094] When oxygen-ion solid electrolyte membranes are used in H₂S-powered fuel cells, two mechanisms for sulfur removal from the anode 720 surface are used: 1) the sulfur electrochemical oxidation to gaseous SO_x; and 2) the formation of elemental sulfur. The formation of elemental sulfur is common in electrochemical cells equipped with proton (H⁺) conducting membranes, and SO_x is not formed. However, under high current densities and H₂S concentrations, a significant amount of elemental sulfur (S_n) is produced at the anode, which creates a situation where sulfur removal is desired. In embodiments, sulfur may be removed by introducing a feed stream comprising CO₂ to function as an oxidant at the anode 720, which facilitates the removal of sulfur species by forming SO₂, as shown in Reaction (19) below:

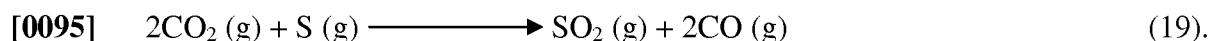

[0096] As shown in FIG. 7A, a feed stream comprising a mixture of CO₂ and H₂S is fed to the anode 720 of the electrolyzer 700 via inlet channel 760. H₂S is electrolyzed to hydrogen and sulfur, while the gaseous CO₂ and sulfur react according to Reaction (19) to form CO and

SO₂, which exit the electrolyzer 700 at outlet channel 765. As shown in FIG. 8A and FIG. 8B, where the enthalpy and Gibbs free energy of Reaction (19) are shown as a function of temperature, Reaction (19) appears to be spontaneous (as indicated by Gibbs free energy below 0) and slightly exothermic (as shown by enthalpy below 0). Thus, it is very likely that at high temperatures, CO₂ will dissociate to gaseous CO and atomic oxygen adsorbed on the anode surface that will oxidize sulfur to gaseous SO₂. In embodiments, the temperatures for dissociating CO₂ are from about 250 to about 1300 °K, such as from about 500 to about 1000 °K, or even from about 600 to about 800 °K.

[0097] In further embodiments, the hydrogen H₂ dissociated from the H₂S will be disassociated into H⁺ ions when an electrical current is applied to the anode 720. The electrical current may be provided via an electrical device 710 and an electrical connection 715. The H⁺ ions will transfer across the electrolyte 740, as indicated by arrow 750, to the cathode 730. In the embodiments shown in FIG. 7A, a feed stream comprising CO₂ is fed to the cathode 730 of the electrolyzer 700 via inlet channel 770. The CO₂ reacts with the hydrogen according to Reaction (16) at the three phase boundary to form C_xH_yO_z that exits the electrolyzer 700 at outlet channel 775.

[0098] FIG. 7B shows an embodiment comprising a fuel cell using CO₂ to aid removal of sulfur. In the embodiment of FIG. 7A, an electrolyzer 700 is shown including a housing 701 having inlet channels 760 and 770 and outlet channel 775. Within the housing are an anode 720, a cathode 730, and an electrolyte 740 positioned between, and in electrochemical communication with, the anode 720 and the cathode 730. As discussed above with reference to FIG. 7A, a feed stream comprising CO₂ is fed to the anode 720 of the fuel cell 700 via inlet channel 760 to aid in the removal of sulfur.

[0099] In the embodiment shown in FIG. 7B, a feed stream comprising a mixture of CO₂ and H₂S is fed to the anode 720 of the electrolyzer 700 via inlet channel 760. The gaseous CO₂ and sulfur react according to Reaction (19) to form CO and SO₂, which exit the electrolyzer 700 at outlet channel 765.

[00100] In embodiments, the hydrogen dissociated from the H₂S will transfer across the electrolyte 740, as indicated by arrow 750, to the cathode 730. In the embodiments shown in

FIG. 7B, O₂ or air is fed via inlet channel 770 that reacts with H⁺ at the cathode and water is formed which exits the electrolyzer 700 at outlet channel 775, and electricity is generated in the fuel cell from the transfer of protons across the electrolyte and sent from the fuel cell to an electrical device 710 via an electrical connection 715.

EXAMPLES

[00101] Embodiments will be further clarified by the following example and comparative example.

[00102] Example

[00103] In this example the electrical power required to hydrogenate a maximum possible amount of CO₂ to CH₄ is calculated. For this example, an electrochemical reactor as shown in FIG. 5 is integrated into a refinery or other gas plant that has the following specifications: H₂S mass flow rate of 1 ton/h; CO₂ mass flow rate of 1 ton/h; and the required H₂S conversion is 100%. From the above, it is estimated (from stoichiometric calculations) that from each ton of H₂S, 0.94 ton/h of elemental sulfur and 0.059 ton/h of H₂ can be generated by electrochemical splitting by aiming for 100% H₂S elimination.

[00104] The above requires $2 \times 0.059 = 0.118$ ton H⁺/h or 16.3 mol H⁺/s through the proton conducting electrolyte membrane, which is equivalent to a 1573 kA current and 3.3 MW power, assuming that the electrolysis unit operates at about 2.1 V (this assumption is based on about 0.2 V anode overpotential and 1.9 V cathode overpotential (according to H₂S electrochemical oxidation and CO₂ electrochemical reduction studies), and the Faradaic efficiency reaches 100%).

[00105] Using the above numbers and assuming that all H⁺ are used to hydrogenate CO₂ and not to form H₂ gas, 0.117 ton/h CH₄ and 0.53 ton/h H₂O are produced, which corresponds to about 32% conversion of CO₂ in the total CO₂ fed to the reactor. If the desired product is CH₃OH rather than CH₄, the same amount of power (or H⁺ species) produces 0.31 ton/h CH₃OH and 0.18 ton/h H₂O, which corresponds to CO₂ conversion of about 43%.

[00106] This example shows an estimation of power consumption for the electrochemical system described above and described with respect to FIG. 5. The example also shows the importance of product selection as it is estimated that over 10% more CO₂ is converted when methanol is the desired product as opposed to methane. This is believed to be because CH₃OH formation requires less H⁺ than CH₄ formation, which combined with the higher heating value of CH₃OH than CH₄ (4 kJ/mol versus 0.75 kJ/mol, respectively) can significantly benefit the economics of the process.

[00107] Comparative Example

[00108] This Comparative Example shows electrolysis using H₂O in place of H₂S. With reference now to FIG. 6, an electrolyzer 600 includes a housing 601 having inlet channels 660 and 670 and outlet channels 665 and 675. Positioned within the housing are an anode 620, an electrolyte 640, and a cathode 630. In the embodiments shown in FIG. 6, H₂O is fed to the anode 620 of the electrolyzer 600 via inlet channel 660 in the housing 601. The H₂O is split into elemental oxygen and hydrogen as shown in Reaction (20) below:

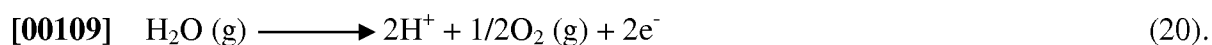

[00110] The elemental oxygen exits the electrolyzer 600 at outlet channel 665 in the housing 601. An electrical current is provided by current source 610 to the anode by electrical connection 615. The electrical current is provided to the anode 620 and disassociates water into H⁺ ions that are transferred across the electrolyte 640 to the cathode 630, as shown by arrow 650. CO₂ is fed to the cathode 630 of the electrolyzer 600 via inlet channel 670. At the cathode, CO₂ hydrogenation can occur electrochemically, as shown in Reaction (16) or catalytically, as shown in Reactions (9) and (10). The method of this comparative example produces pure O₂ as reaction product, which can be used in many different oxidation reactions. However, power demand for H₂O electrolysis is estimated to be about 1.94 MW (i.e., about 6 times higher than that of H₂S electrolysis), since the water reduction potential is 1.23 V vs. 0.2 V for H₂S at ambient conditions.

[00111] Thus, various embodiments of methods for co-processing CO₂ and H₂S have been described. In the methods, a feed stream comprising H₂S is fed to an anode side of an

electrolyzer so that the H₂S is split into hydrogen and elemental sulfur. The hydrogen may then be transferred across an electrolyte to a cathode. A gas stream comprising CO₂ is fed at a cathode side of the electrolyzer. The CO₂ is hydrogenated by the hydrogen that is transferred across the electrolyte and is hydrogenated into a more useful chemical product, such as methane or methanol. In various embodiments, additional components may be fed to the electrolyzer with the feed streams comprising H₂S and CO₂. For example, in some embodiments CO may be fed to the anode side of the electrolyzer with the gas stream comprising H₂S so that the H₂S reacts with the CO at the anode side of the electrolyzer to form COS and H₂. In some embodiments, an additional hydrogen source may be fed to the cathode side of the electrolyzer with the CO₂ to aid in the hydrogenation of the CO₂. Unlike with conventional processes that split H₂S and hydrogenate CO₂ separately, co-processing H₂S and CO₂ creates efficiencies, such as reducing the number of units required to process H₂S and CO₂, by removing the adsorbed sulfur on the anode to the gas phase as SO_x, and by using less energy than processes that treat H₂S and CO₂ separately.

[00112] It will be apparent to those skilled in the art that various modifications and variations can be made to the embodiments described herein without departing from the spirit and scope of the claimed subject matter. Thus it is intended that the specification cover the modifications and variations of the various embodiments described herein provided such modification and variations come within the scope of the appended claims and their equivalents.

-25-

CLAIMS

1. A method for co-processing H₂S and CO₂ in an electrolyzer that comprises an anode, a cathode, and an electrolyte positioned between and in electrochemical contact with the anode and the cathode, the method comprising:

feeding a first gas stream comprising H₂S to the anode of the electrolyzer;

feeding a second gas stream comprising CO₂ to the cathode of the electrolyzer;

splitting H₂S of the first gas stream into hydrogen and elemental sulfur;

transferring the hydrogen split from the H₂S of the first gas stream from the anode across the electrolyte to the cathode; and

hydrogenating the CO₂ from the second gas stream with the hydrogen that was transferred from the anode.

2. The method of claim 1, wherein the CO₂ from the second gas stream is hydrogenated according to a reaction as follows:

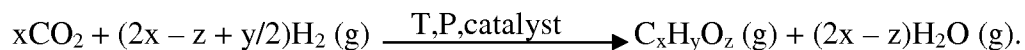

3. The method of claim 2, wherein the CO₂ from the second gas stream is hydrogenated to form water and one of methane and methanol.

4. The method of claim 1, wherein the anode comprises a metal sulfide.

5. The method of claim 1, wherein the anode comprises a member selected from the group consisting of NiS, MoS₂, WS₂, CoS, Li₂S/CoS_{1.35}, FeMoS, NiMoS, CoMoS, VO₅, LiCoO₂, Pt/TiO₂, Pd, Au, Ag, Ru, Rh, Ir, Nb₂O₅-Ni, BaO-Ni, Ce_{0.8}Sm_{0.2}O₂-Ni, CuFe₂S₄, CuNi₂S₄, CuCoS₄, NiCo₂S₄, NiFe₂S₄, and mixed metal oxides of La, Sr, Mn, Ti, Cr, Ga, Y, V, Fe, Co, Mo, Ce, Mg, Gd, and Ba.

6. The method of claim 1, wherein the electrolyte comprises a member selected from the group consisting of perovskite materials of the general type ABO₃ and ABMO₃ that exhibit proton conductivity at high temperatures, zirconia- and ceria-based proton conducting

electrolytes, and solid acids of the general type MHXO_4 and $\text{M}_3\text{H}(\text{XO}_4)_2$, where M is Cs, NH_4 , Rb, and X is S or Se.

7. The method of claim 1, wherein CO is added to the first gas stream, and the method further comprises forming carbonyl sulfide.

8. The method of claim 7, wherein the method further comprises feeding the carbonyl sulfide to a decomposer where the carbonyl sulfide is split into elemental sulfur and CO.

9. The method of claim 8, wherein the CO produced in the decomposer by splitting the carbonyl sulfide is the CO added to the first gas stream.

10. The method of claim 1, wherein the second gas stream comprises CO_2 and an additional hydrogen source.

11. The method of claim 10, wherein the hydrogen split from the H_2S of the first gas stream is transferred from the anode across the electrolyte and form promoting species on the cathode.

12. The method of claim 1, wherein the first gas stream comprises H_2S and CO_2 and the method further comprises forming SO_x and CO after the H_2S in the first gas stream is split into hydrogen and elemental sulfur.

13. A method for producing electricity in a fuel cell that comprises an anode, a cathode, and an electrolyte positioned between and in electrochemical contact with the anode and cathode, the method comprising:

feeding a first gas stream comprising H_2S and CO to the anode;

feeding a second gas stream comprising oxygen to the cathode;

forming carbonyl sulfide from the H_2S of the first gas stream and the CO of the first gas stream;

-27-

transferring the hydrogen split from the H₂S of the first gas stream from the anode across the electrolyte to the cathode;

electrochemically reducing the hydrogen that is transferred from the anode across the electrolyte to the cathode with the oxygen of the second gas stream; and

collecting electricity formed from the oxidizing of the hydrogen that is transferred from the anode across the electrolyte to the cathode.

14. The method of claim 13, wherein the method further comprises feeding the carbonyl sulfide to a decomposer where the carbonyl sulfide is split into elemental sulfur and CO.

15. The method of claim 14, wherein the CO produced in the decomposer by splitting the carbonyl sulfide is the CO of the first gas stream.

16. The method of claim 13, wherein the anode comprises a member selected from the group consisting of Co₉S₈, NiS, FeS, MnS, Cr₂S₃, ZnS, MoS₂, Cu₂S, V₃S₄, Ti₅S₄, WS₂, CuFe₂S₄, CuNi₂S₄, CuCoS₄, NiCo₂S₄, NiFe₂S₄, YSZ, ScSZ, ScYSZ, GDC, CGO, CeO₂, TiO₂, Nb₂O₅, SDC, BCY, CZI, and BCN.

17. The method of claim 13, wherein the electrolyte comprises a member selected from the group consisting of perovskite materials of the general type ABO₃ and ABMO₃ that exhibit proton conductivity at high temperatures, zirconia- and ceria-based proton conducting electrolytes, and solid acids of the general type MHXO₄ and M₃H(XO₄)₂, where M is Cs, NH₄, Rb, and X is S or Se.

18. A method for producing electricity in a fuel cell that comprises an anode, a cathode, and an electrolyte positioned between and in electrochemical contact with the anode and cathode, the method comprising:

feeding a first gas stream comprising H₂S and CO₂ to the anode;

splitting the H₂S from the first gas stream into hydrogen and elemental sulfur;

forming SO_x and CO from the elemental sulfur split from the H₂S of the first gas stream and the CO₂ of the first gas stream;

-28-

transferring the hydrogen split from the H₂S of the first gas stream from the anode across the electrolyte to the cathode;

exhausting the hydrogen transferred from the anode across the electrolyte to the cathode from the fuel cell; and

collecting electricity formed from the oxidizing of the hydrogen that is transferred from the anode across the electrolyte to the cathode.

19. The method of claim 18, wherein the anode comprises a metal sulfide selected from the group consisting of NiS, MoS₂, WS₂, CoS, Li₂S/CoS_{1.35}, FeMoS, NiMoS, CoMoS, VO₅, LiCoO₂, Pt/TiO₂, Pd, Au, Ag, Ru, Rh, Ir, Nb₂O₅-Ni, BaO-Ni, Ce_{0.8}Sm_{0.2}O₂-NiCuFe₂S₄, CuNi₂S₄, CuCoS₄, NiCo₂S₄, NiFe₂S₄, La, Sr, Mn, Ti, Cr, Ga, Y, V, Fe, Co, Mo, Ce, Mg, Gd, Ba, YSZ, ScSZ, ScYSZ, GDC, CGO, CeO₂, TiO₂, Nb₂O₅, SDC, BCY, CZI, and BCN.

20. The method of claim 18, wherein the electrolyte comprises a member selected from the group consisting of perovskite materials of the general type ABO₃ and ABMO₃ that exhibit proton conductivity at high temperatures, zirconia- and ceria-based proton conducting electrolytes, solid acids of the general type MHXO₄ and M₃H(XO₄)₂, where M is Cs, NH₄, Rb, and X is S or Se.

1/8

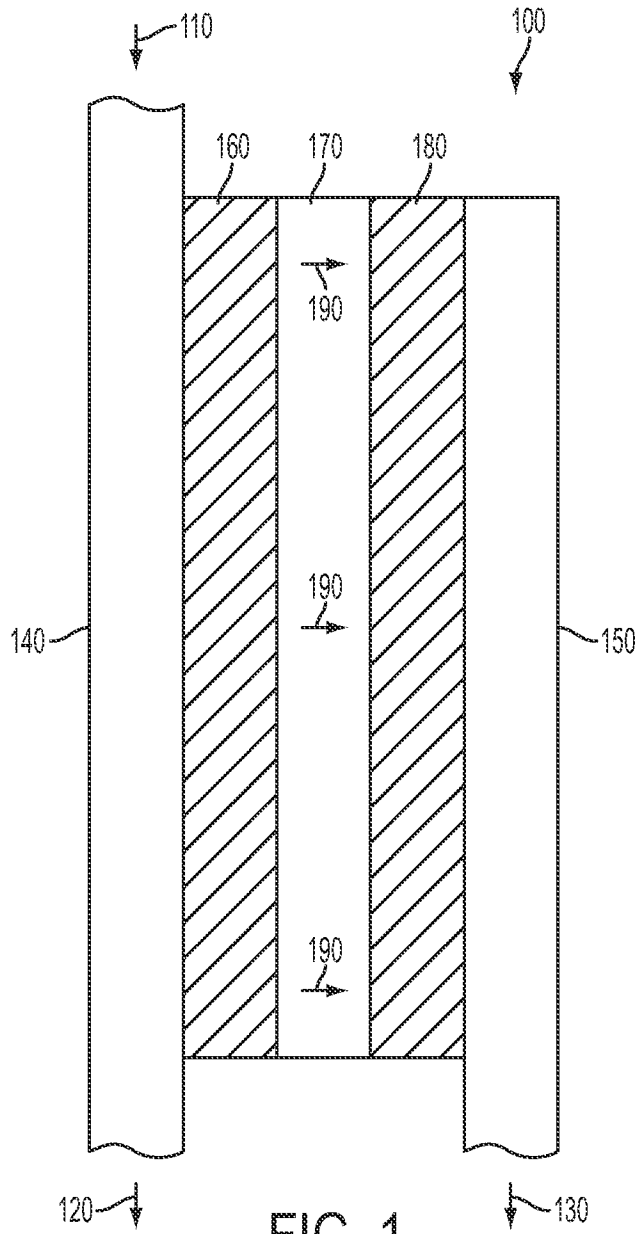

FIG. 1
Prior Art

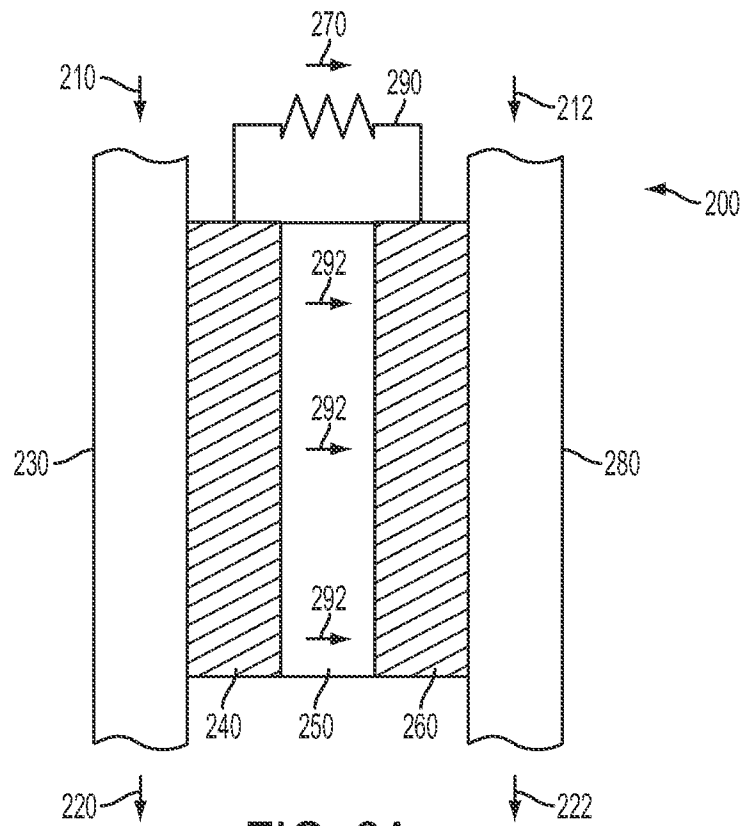

FIG. 2A
Prior Art

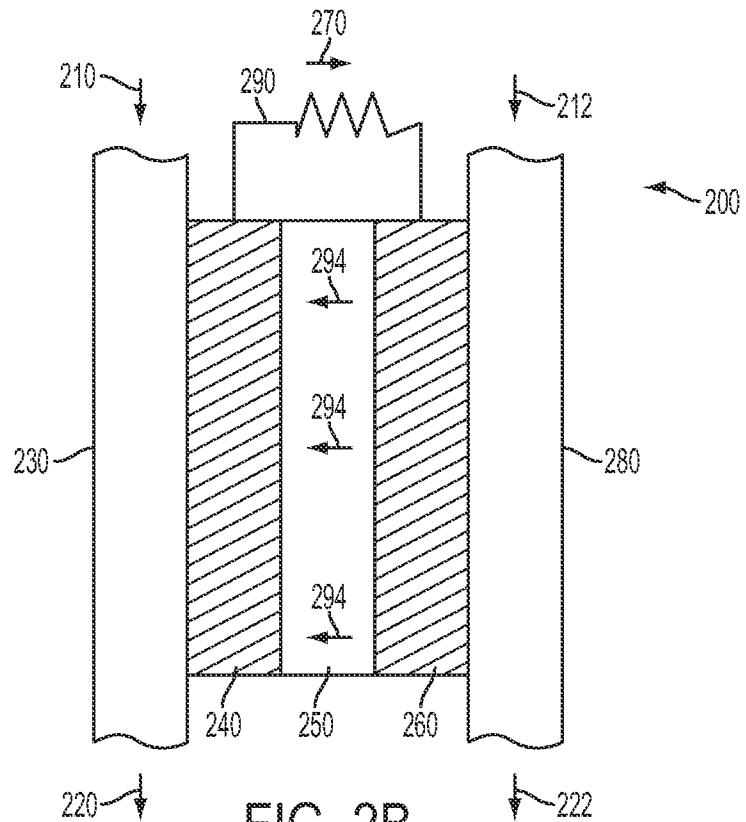

FIG. 2B
Prior Art

3/8

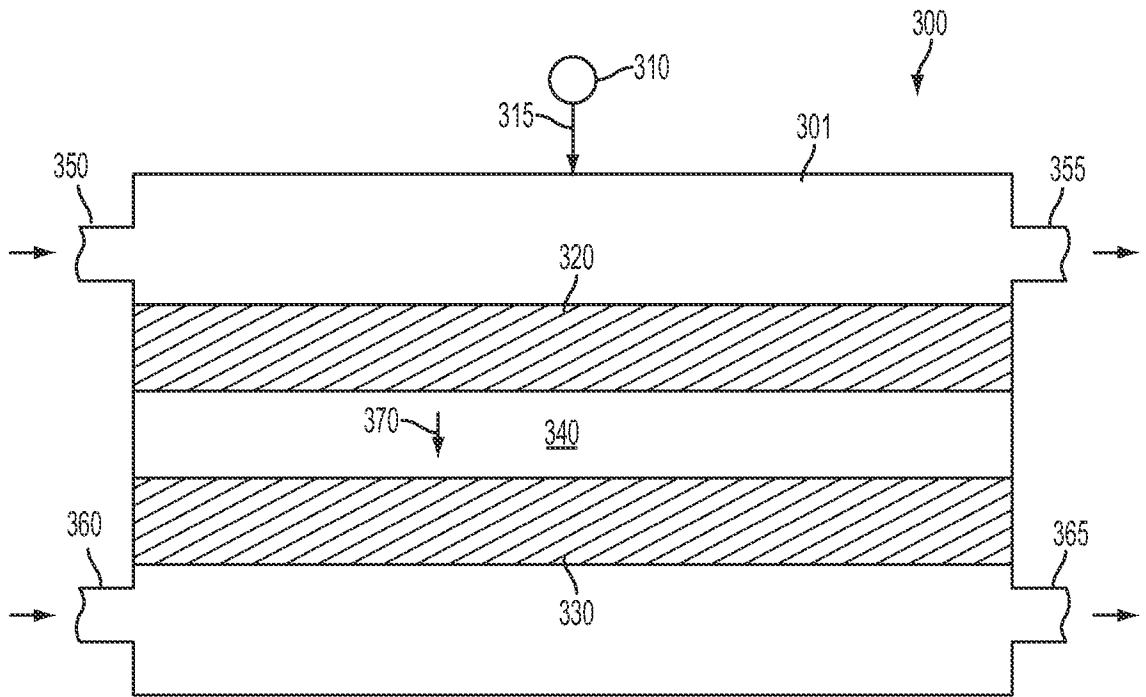

FIG. 3

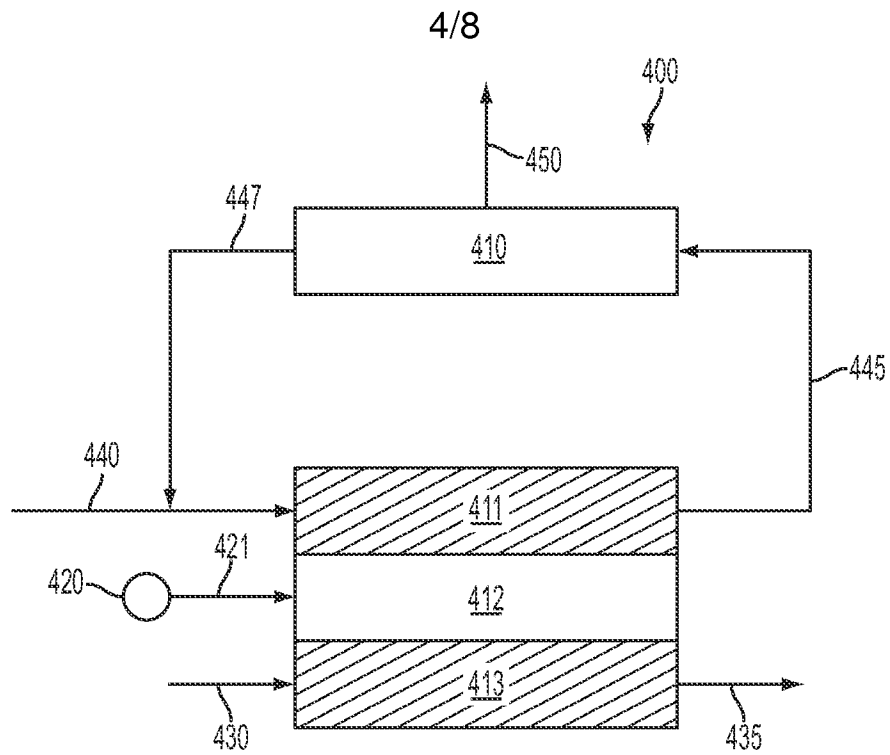

FIG. 4A

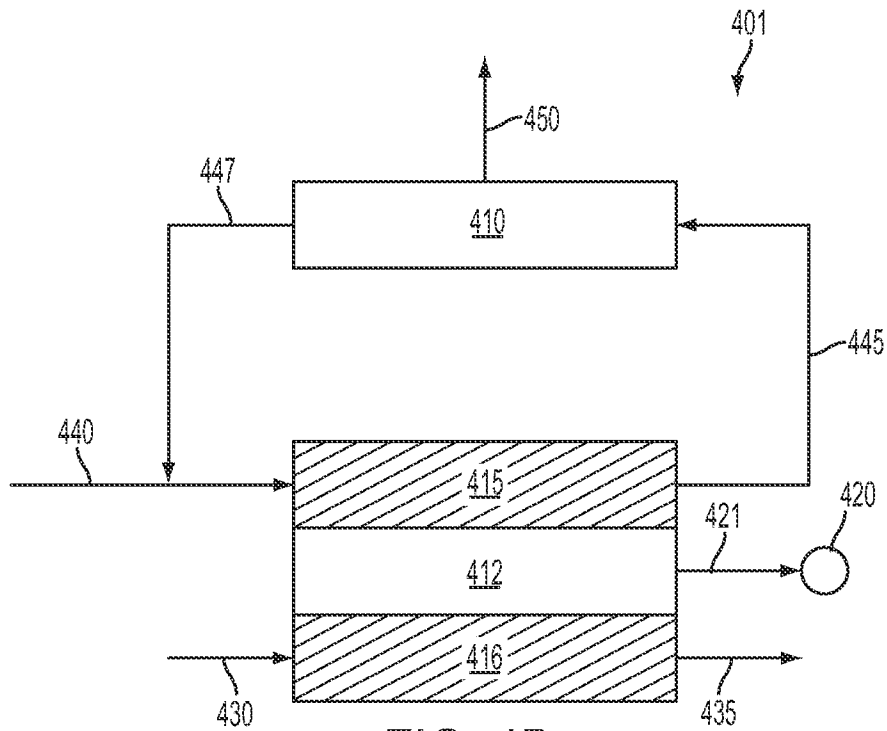

FIG. 4B

5/8

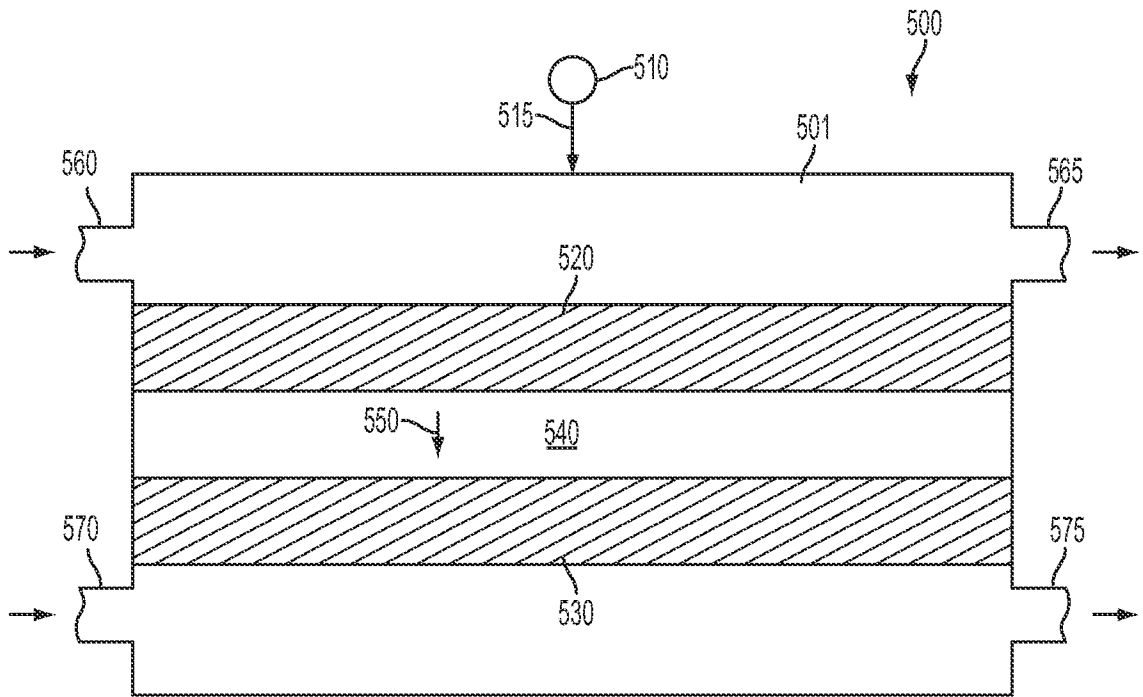

FIG. 5

6/8

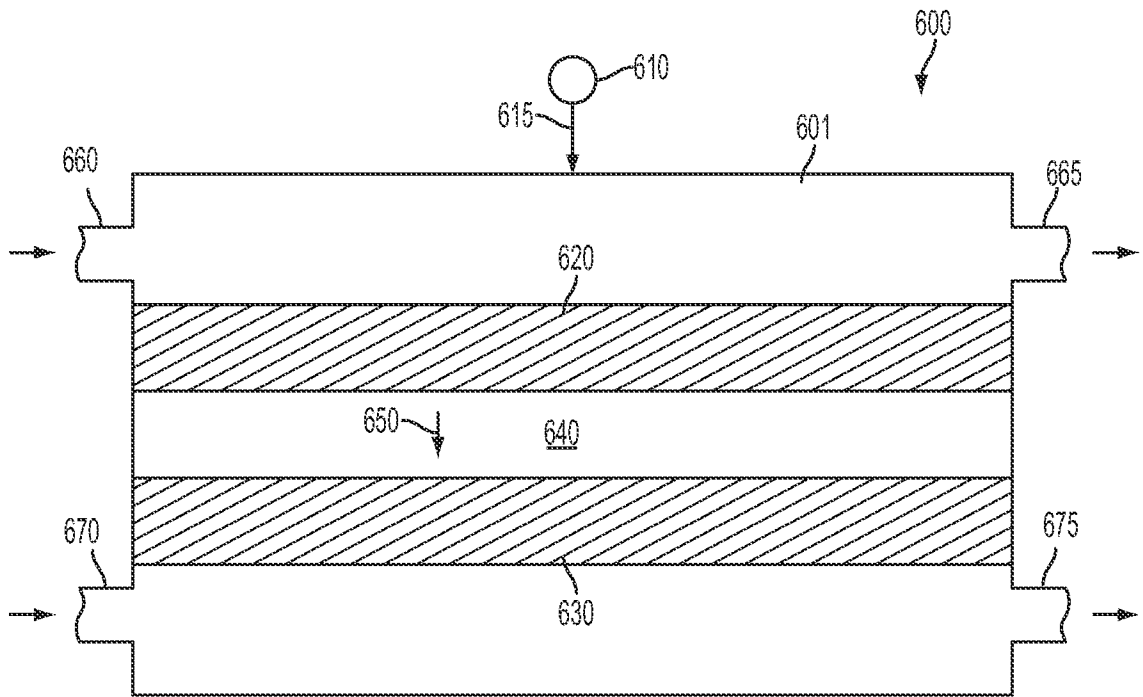

FIG. 6

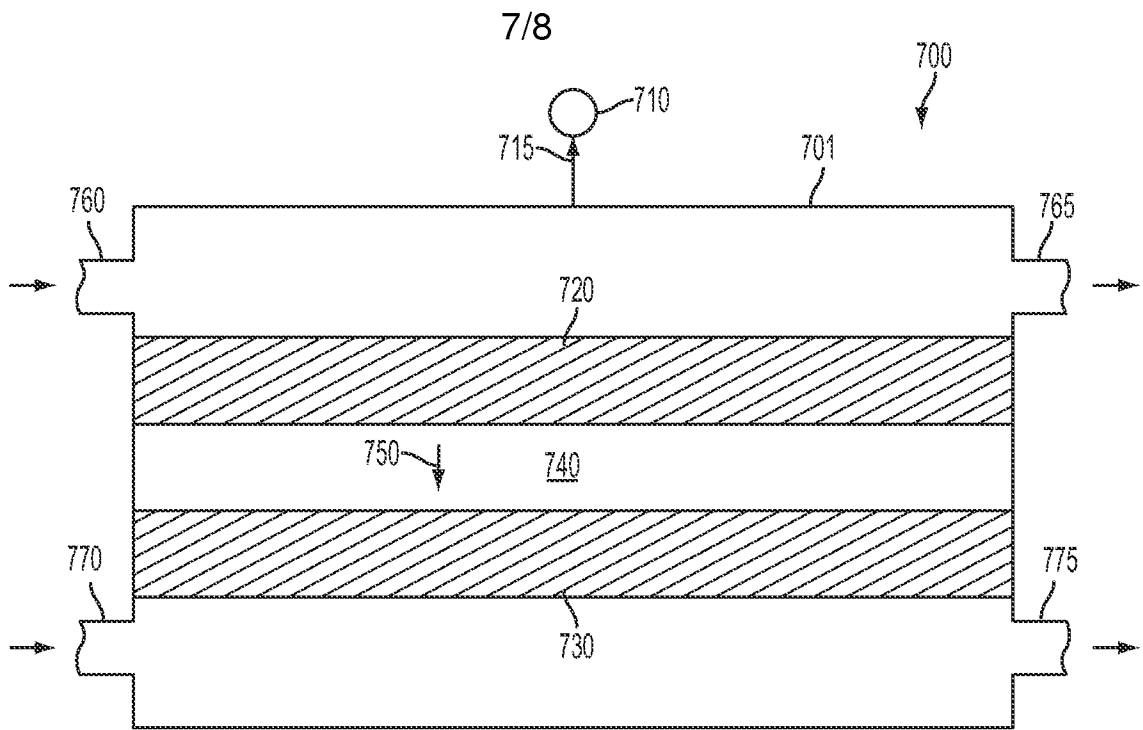

FIG. 7A

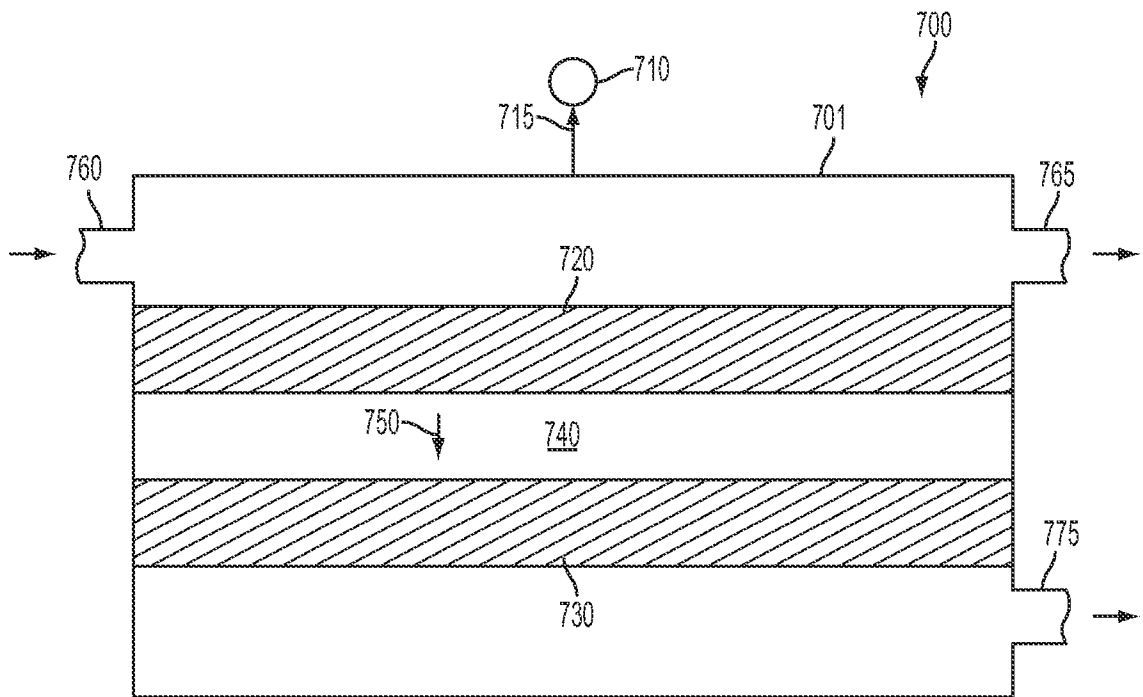

FIG. 7B

8/8

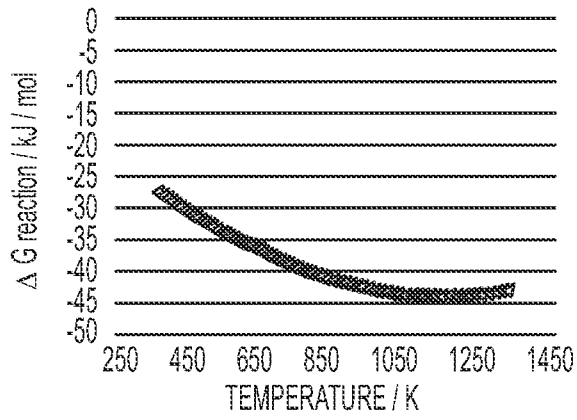

FIG. 8A

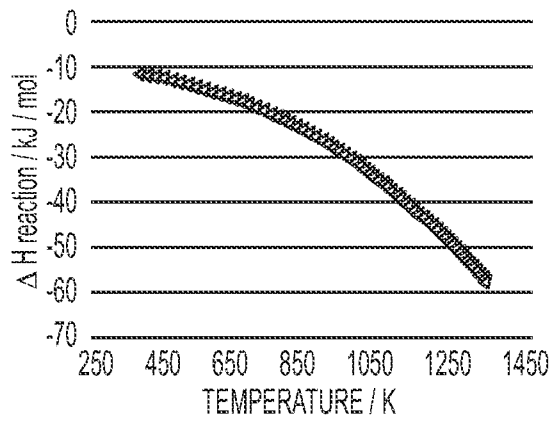

FIG. 8B

INTERNATIONAL SEARCH REPORT

International application No
PCT/US2015/055492

A. CLASSIFICATION OF SUBJECT MATTER
INV. C25B1/00 C25B5/00 H01M8/22
ADD.
According to International Patent Classification (IPC) or to both national classification and IPC

B. FIELDS SEARCHED
Minimum documentation searched (classification system followed by classification symbols)
C25B H01M

Documentation searched other than minimum documentation to the extent that such documents are included in the fields searched

Electronic data base consulted during the international search (name of data base and, where practicable, search terms used)
EPO-Internal, WPI Data

C. DOCUMENTS CONSIDERED TO BE RELEVANT

Category*	Citation of document, with indication, where appropriate, of the relevant passages	Relevant to claim No.
Y	US 2003/215696 A1 (CHUANG KARL T [CA] ET AL) 20 November 2003 (2003-11-20) the whole document paragraphs [0069], [0074]; claims 1,3-5 -----	1-20
Y	US 3 249 522 A (BOLMER PERCE W) 3 May 1966 (1966-05-03) column 1, lines 11-18 column 6, lines 36-58 -----	1-20
Y	UA 61 556 U (INST OF BIOORG CHEMISTRY AND PETROCHEMISTRY OF NAS OF UKRAINE [UA]) 25 July 2011 (2011-07-25) abstract -----	1-20
	-/--	

Further documents are listed in the continuation of Box C.

See patent family annex.

* Special categories of cited documents :

- "A" document defining the general state of the art which is not considered to be of particular relevance
- "E" earlier application or patent but published on or after the international filing date
- "L" document which may throw doubts on priority claim(s) or which is cited to establish the publication date of another citation or other special reason (as specified)
- "O" document referring to an oral disclosure, use, exhibition or other means
- "P" document published prior to the international filing date but later than the priority date claimed

- "T" later document published after the international filing date or priority date and not in conflict with the application but cited to understand the principle or theory underlying the invention
- "X" document of particular relevance; the claimed invention cannot be considered novel or cannot be considered to involve an inventive step when the document is taken alone
- "Y" document of particular relevance; the claimed invention cannot be considered to involve an inventive step when the document is combined with one or more other such documents, such combination being obvious to a person skilled in the art
- "&" document member of the same patent family

Date of the actual completion of the international search 22 January 2016	Date of mailing of the international search report 09/02/2016
Name and mailing address of the ISA/ European Patent Office, P.B. 5818 Patentlaan 2 NL - 2280 HV Rijswijk Tel. (+31-70) 340-2040, Fax: (+31-70) 340-3016	Authorized officer Hammerstein, G

INTERNATIONAL SEARCH REPORT

International application No
PCT/US2015/055492

C(Continuation). DOCUMENTS CONSIDERED TO BE RELEVANT		
Category*	Citation of document, with indication, where appropriate, of the relevant passages	Relevant to claim No.
Y	UA 62 880 U (INST OF BIOORG CHEMISTRY AND PETROCHEMISTRY OF NAS OF UKRAINE [UA]) 26 September 2011 (2011-09-26) abstract	1-20
A	----- US 4 544 461 A (VENKATESAN SRINIVASAN [US] ET AL) 1 October 1985 (1985-10-01) column 2, lines 48-61 column 3, lines 21-43 column 4, lines 27-39; figures 1,3 column 4, line 65 - column 5, line 8 column 6, lines 35-55	1-20
A	----- UA 99 863 C2 (INST OF BIOORG CHEMISTRY AND PETROCHEMISTRY OF NAS OF UKRAINE [UA]) 10 October 2012 (2012-10-10) abstract	13-20

INTERNATIONAL SEARCH REPORT

Information on patent family members

International application No PCT/US2015/055492

Patent document cited in search report	Publication date	Patent family member(s)	Publication date
US 2003215696	A1	20-11-2003	NONE

US 3249522	A	03-05-1966	NONE

UA 61556	U	25-07-2011	NONE

UA 62880	U	26-09-2011	NONE

US 4544461	A	01-10-1985	NONE
		AU 566843 B2	29-10-1987
		AU 2610484 A	04-10-1984
		CA 1236049 A	03-05-1988
		EP 0127595 A2	05-12-1984
		JP H0645910 B2	15-06-1994
		JP S59190380 A	29-10-1984
		US 4544461 A	01-10-1985

UA 99863	C2	10-10-2012	NONE
